

# Amity Air Carts

## Stainless steel lasts a lifetime

Amity Air Carts allow you to precisely, yet gently, deliver seed and fertilizer to all Amity Air Drills. An Amity Air Cart is the ideal complement to our Single Disc Drill and Amity Air Carts feed virtually any seeding tool or fertilizer applicator already on your farm. Choose from ground-driven meters or hydraulic-driven variable rate meters, variable  $\text{NH}_3$  controls, optional tire sizes and axle spacing.

Our new ISO compliant monitors offer state-of-the-art technology and are compatible with most other in-cab terminals and many mapping application technologies. The bottom line is Amity provides advanced stainless steel air carts and meters for a lifetime of durable, attractive and low maintenance operation.

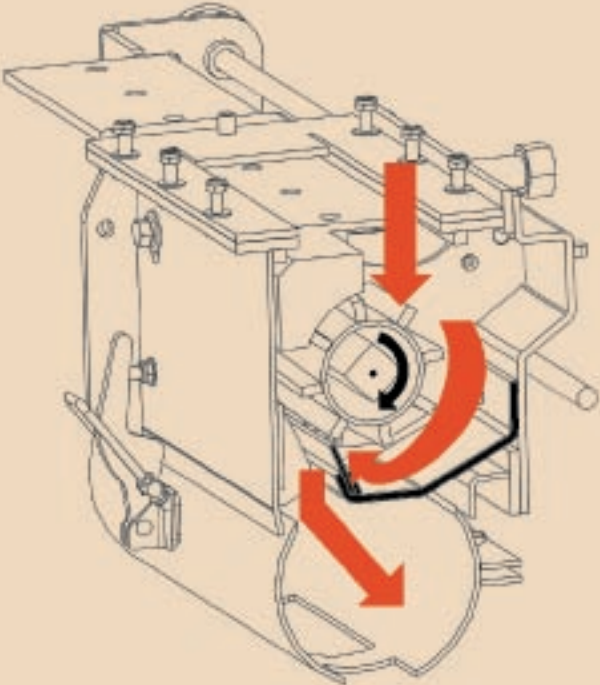

## Maintenance-free meters

Amity re-engineered the metering system so it is virtually maintenance free. Our meter will gently handle all types of seed (including small seeds), yet accurately deliver any type of granular fertilizer without corrosion or excessive maintenance.





5250 Air Cart  
(tow-between  
or tow-behind)



ST250 Air Cart



2800/3350 Air Cart

Models	Capacity	Bins
ST250	200 bu.	1
2800	280 bu.	2
3350	335 bu.	2
5250	525 bu.	3

# Air Cart Specifications

Model	5250	3350	2800	ST250
<b>Product capacity</b>	525 bu. (19 ton) (18 500 L)	335 bu. (12 ton) (11 805 L)	280 bu. (10 ton) (9866 L)	200 bu. (7 ton) (7047 L)
<b>Compartments</b>	3	2	2	1
<b>Splits</b>	175/225/125 bu. (6166/7928/4404 L)	200/135 bu. (7047/4757 L)	168/112 bu. (5920/3946 L)	200 bu. (7047 L)
<b>Single shoot/Double shoot</b>	Single or Double	Single (Double optional)	Single (Double optional)	Single
<b>Dimensions</b>				
<b>Working height</b>	17 ft. (5.18 m)	13 ft. 4 in. (4.06 m)	12 ft. 8 in. (3.86 m)	12 ft. 2 in. (3.71 m)
<b>Working width</b>	16 ft. 6 in. (4.95 m)	11 ft. 5 in. (3.48 m)	11 ft. 5 in. (3.48 m)	11 ft. 5 in. (3.48 m)
<b>Working length</b>	30 ft. 2 in. (9.54 m)	27 ft. (8.23 m)	27 ft. (8.23 m)	25 ft. 6 in. (7.77 m)
<b>Weight (empty)*</b>	15,750 lb. (7144 kg)	8,700 lb. (3946 kg)	8,500 lb. (3856 kg)	5,200 lb. (2359 kg)
<b>Fill height</b>	11 ft. 9 in. (3.58 m)	11 ft. 8 in. (3.56 m)	11 ft. 2 in. (3.40 m)	10 ft. 6 in. (3.20 m)
<b>Shipping height</b>	10 ft. 5 in. (3.18 m)	10 ft. 3 in. (3.12 m)	9 ft. 6 in. (2.89 m)	8 ft. 7 in. (2.62 m)
<b>Width</b>	7 ft. 6 in. (2.28 m)	8 ft. 4 in. (2.54 m)	8 ft. 4 in. (2.54 m)	7 ft. 3 in. (2.21 m)
<b>Length</b>	28 ft. 3 in. (8.61 m)	19 ft. 2 in. (5.84 m)	19 ft. 2 in. (5.84 m)	18 ft. 6 in. (5.64 m)
<b>Tire size and spacing</b>				
<b>Configuration</b>	Single axle (duals)	Two axles (singles)	Two axles (singles)	Single axle (single) front castor option
<b>Standard size</b>	24.5 x 42 R1	23.1 x 26 R1	23.1 x 26 R1	18.4 x 26 R1
<b>Optional size</b>	None	18.4 x 26 R1	18.4 x 26 R1	None
20 in. (50.8 cm) and 30 in. (76.2 cm) row crop compatible spacing on all models				
<b>Other features</b>				
<b>Fan drive</b>	Single or Dual	Single (Dual optional)	Single (Dual optional)	Single
<b>Meter drives</b>	Hydraulic	Ground and Hydraulic	Ground and Hydraulic	Ground and Hydraulic
<b>Fill auger (poly flighting)</b>	10 in. (25.4 cm) x 25 ft. (7.6 m)	8 in. (20.3 cm) x 18 ft. (5.5 m)	8 in. (20.3 cm) x 18 ft. (5.5 m)	8 in. (20.3 cm) x 18 ft. (5.5 m)
<b>Work switch (auto start/stop)</b>	Optional	Optional	Optional	Optional

\*Estimated weights

