

PARTS MANUAL

2015
DEFOLIATOR
3550 8R22/6R30

Amity
TECHNOLOGY

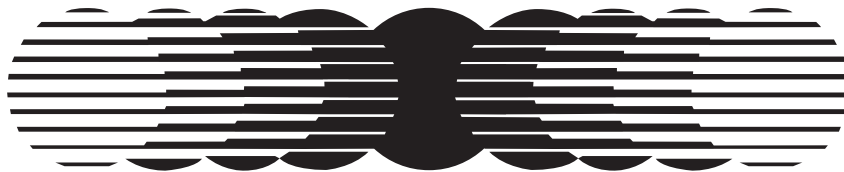

2800 7TH Avenue North
Fargo, ND 58102

Phone: (701) 232-4199
Fax: (701) 234-1716
www.amitytech.com

TABLE OF CONTENTS

HITCH ASSEMBLY	1-4
DRIVE TRAIN	5-6
#2 FLAILS.....	7-10
#3 FLAILS.....	11-14
FLAIL TUBE ASSEMBLY	15-16
FLAIL TUBE MOUNTING	17-18
SIDE DOORS AND SHIELDS.....	19-20
SIDE PLASTIC ASSEMBLY	21-22
TOP DOOR ASSEMBLY	23-24
TOP DOOR HYDRAULICS	25-26
STANDARD REAR STRUTS-11.2 X 24 TIRES.....	27-28
OCSILLATING SPINDLE HOUSING	29-30
STANDARD REAR STRUTS-7.6 X 15 TIRES.....	31-32
STEERABLE REAR STRUTS-11.2 X 24 TIRES.....	33-36
STEERABLE REAR STRUTS-7.6 X 15 TIRES.....	37-40
SCALPER BAR ASSEMBLY	41-42
SCALPER BASKET	43-44
SCALPER HYDRAULICS.....	45-46
VALVE BLOCK AND MOUNT.....	47-49
SCRAPER MOUNTED ROW FINDER 12ROW.....	51-52
SCALPER MOUNTED ROW FINDER HYDRAULICS.....	53-54
FRAME MOUNTED ROWFINDER.....	55-56
ASSY-ROW FINDER MOUNT.....	57-58
FRAME MOUNTED ROWFINDER HYDRAULICS.....	59-60
HYDRAULIC ROW FINDER.....	61-64
HITCH HYDRAULICS.....	65-66
LIGHT KIT.....	67-68
DECALS.....	69-72
REAR STRUT HYDRAULICS-11.2 X 24 TIRES (OPTIONAL).....	73-74
GEARBOX-L TYPE #305301	75-76
GEARBOX-L TYPE W/OVERRRUN CLUTCH #305602.....	77-78
GEARBOX-T TYPE #305603	79-80
GEARBOX-T TYPE #305604.....	81-82
PTO-STD 1.75 #305691.....	83-84
PTO-CV 1.75 #305690.....	85-86
SIDE DRIVELINE #305611 & #305612.....	87-88
COUPLER-UNIVERSAL JOINT #68443.....	89-90
SNAP RING PLIERS.....	91

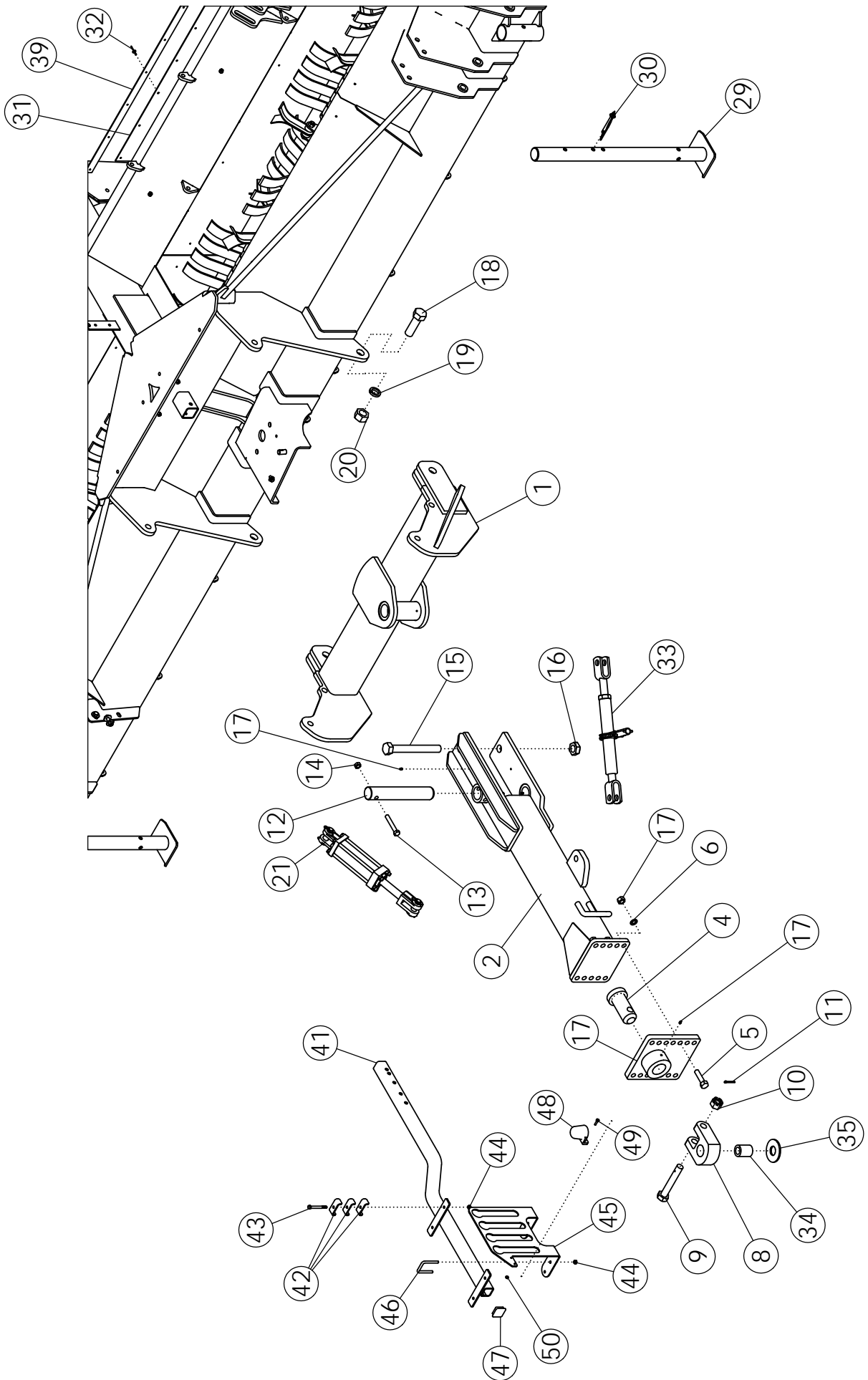

HITCH ASSEMBLY

ITEM	PART NO.	DESCRIPTION	QTY
1	50341	WLDMT - STD HITCH PIVOT	1
2	68277	WLDMT - DRAWPOLE DEF	1
3	57930	WLDMT-HITCH PLATE	1
4	62101	WLDMT-PIN	1
5	1012059	BOLT-HEX: .75 X 3.00 NC GR5 ZP	6
6	1012061	WASHER-LOCK: .75 ZP	6
7	1011620	NUT-HEX: .75 NC GR2 ZP	6
8	64476	PLATE-PULL HITCH	1
9	62477	BOLT-HITCH DRILLED	1
10	62088	NUT-SLOTTED: 1.13 NC GR5 ZP	1
11	1013473	PIN-COTTER: .19 X 2.00 NP	1
12	50678	PIN	1
13	1015117	BOLT-HEX: .63 X 4.00 NC GR8 ZP	1
14	1016595	NUT-TOPLOCK: .63 NC GR5 ZP	1
15	1030756	BOLT-HEX: 1.25 X 10.50 NC GR5 ZP	1
16	1030759	NUT-TOPLOCK: 1.25 NC ZP	1
17	1011748	ZERK - GREASE	4
18	1030757	BOLT-HEX: 1.38 X 4.25 NC GR5 ZP	2
19	1030760	WASHER-LOCK: 1.38 ZP	2
20	1030758	NUT-HEX: 1.38 NC ZP	2
21	58891	CYLINDER-HYDRAULIC 4 X 8" 3000	2
	301315	SEAL KT-CYL 4 X 8, 4 X 10 3000PSI UNIVERSAL	
22	63995	TOP_BRACKET - RH	1
23	63996	TOP_BRACKET - LH	1
24	63383	POLY GUIDE BLOCK	1
25	63999	WLDMT - BOTTOM_BRACKET	1
26	1016211	BOLT-HEX: .25 X 2.00 NC GR5	4
27	1030946	NUT-TOPLOCK: .25 NC GR5 ZP	4
28	63359	COLLAR-SET: .563 ZP	1
29	52073	WLDMT-STAND	2
30	52408	SPRING PIN .50 X 3.50	2
31	305226	LINER-FRONT 12R 3750	4
	305491	LINER-FRONT 8R 3550	2
32	56886	RIVET-POP: .19 X .675 ZP	AR
33	52407	RATCHET JACK-PAINTED	1
34	64615	TUBE-SPACER 2.0 X 1.25	1
	64614	TUBE-SPACER 2.0 X 1.63	
35	58925	WASHER-HARDENED: 4.00 X 1.63	1
36	63406	PIN-CLEVIS: 1.00 X 4.00 ZP	1
37	52448	DECAL-CAUTION	1
38	63405	DECAL-DEPTH GAUGE	1

CONTINUED

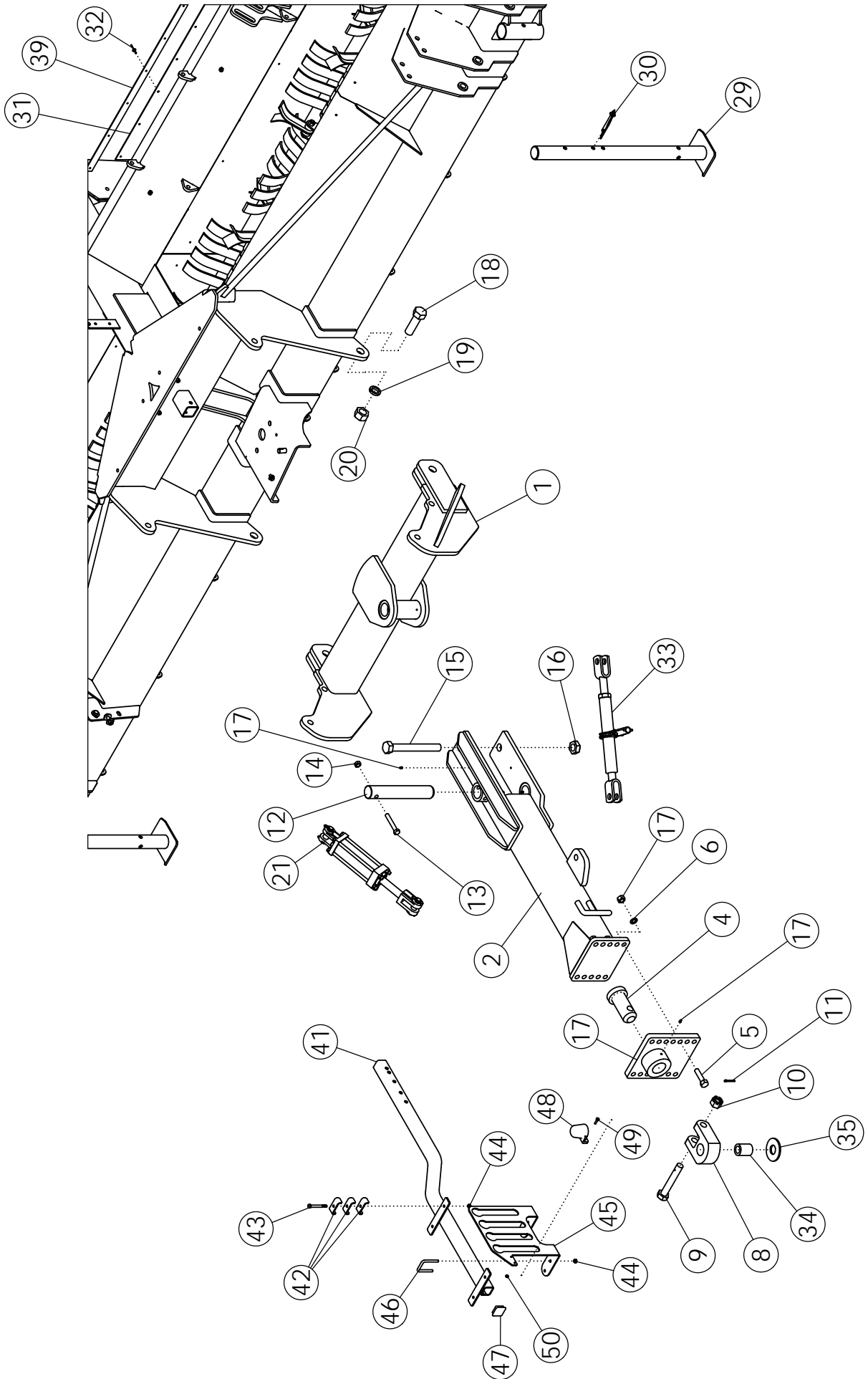

HITCH ASSEMBLY (CONTINUED)

ITEM	PART NO.	DESCRIPTION	QTY
39	305227	BAR-LINER RETAINER 12R 3750	4
	305492	BAR-LINER RETAINER 8R 3550 (NOT SHOWN)	2
	306236	BAR-LINER RETAINER 8R SPLIT-FRM (NOT SHOWN)	2
40	58098	SAFETY CHAIN 20200# (NOT SHOWN)	1
41	301210	WLDMT-HYD HOSE HOLDER	1
42	50714	CLAMP 1/2" ZP	12
43	58176	BOLT-HEX: .38 X 3.50 NC GR5 ZP	4
44	1016999	NUT-TOPLOCK: .38 NC GR5 ZP	8
45	301212	PLATE-HYD HOSE END HOLDER	1
46	33162	U-BOLT: .375 X 3 X 2 X 3	2
47	301129	CAPLUG-2" SQ .188WA	1
48	223329	HOLDER-LIGHT PLUG	1
49	1013423	BOLT-HEX: .25 X 1.00 NC GR5 ZP	2
50	1030946	NUT-TOPLOCK: .25 NC GR5 ZP	2

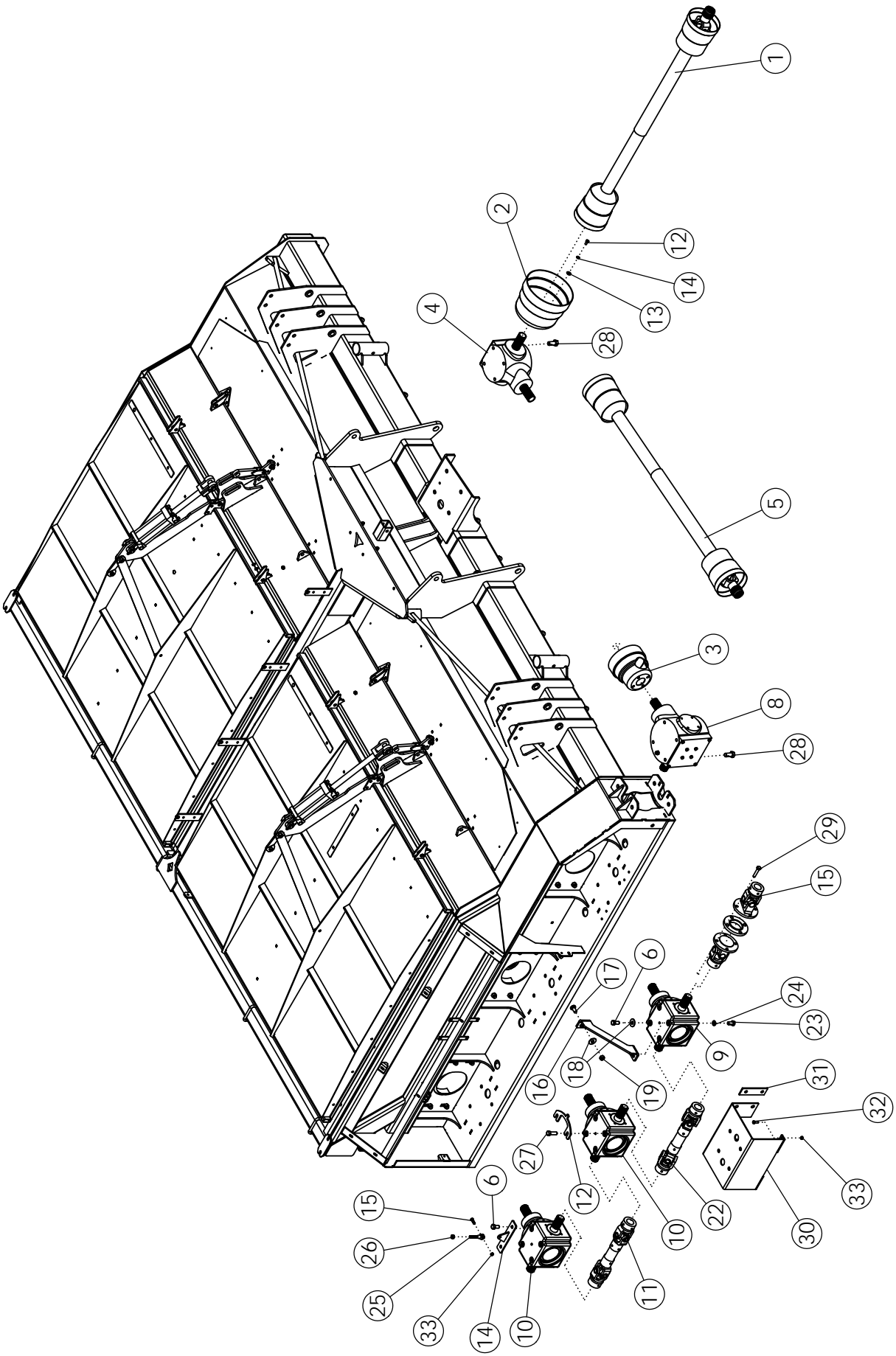

DRIVE TRAIN

ITEM	PART NO.	DESCRIPTION	QTY
1	305690	CONSTANT VELOCITY PTO 1.75"	1
	305691	STANDARD PTO 1.75"	
2	52389	SHIELD CONE-LARGE	1
3	63972	SHIELD-CONE SMALL DRILLED	2
4	305601	GEARBOX-S2155 1.25:1 L	1
5	68604	CROSS SHAFT - 8R	1
6	68449	BOLT-HEX: M16 X 2.0 X L30	24
7	1011813	WASHER-LOCK: .63 ZP	22
8	305602	GEARBOX-S2155 1:1 L W/OVR RN CLU (BLACK)	1
9	305603	GEARBOX-S2125 1:1.35 T (BLACK)	1
10	305604	GEARBOX-S2125 1.93:1 T (BLACK)	2
11	305611	DRIVELINE-SIDE	1
12	68450	BOLT-HEX: M10 X 1.5 X L20	12
13	1011828	WASHER-FLAT: .38 ZP	12
14	1011586	WASHER-LOCK: .38 ZP	12
15	68443	COUPLER-U-JOINT	1
16	68970*	PLATE-GEARBOX SUPPORT	2
17	72063*	BOLT-CRG: .63 X 1.50 NC GR5 ZP	2
18	1013024*	WASHER-FLAT: .63 ZP	4
19	1016595*	NUT-TOPLOCK: .63 NC GR5 ZP	2
20	305154	PLATE-SPACER COUPLER 90 DEG	1
21	305618	PLATE-ADJUSTABLE GEARBOX	1
22	305612	DRIVELINE-SIDE	1
23	305647	BOLT-HEX: M16 X 2.0 X L30 DIN 933-8.8	12
24	1011813	WASHER-LOCK: .63 ZP	12
25	305614	BOLT-CLEVIS .5"	1
26	1013429	NUT-CENTERLOCK: .50 NF GR5 ZP	1
27	305625	BOLT-HEX: M16 X 2.0 X L50 CL8.8 ZP	4
28	305646	BOLT-HEX: M20 X 2.5 X L45 CL8.8 ZP NDP	4
29	305192	BOLT-HEX: .56 X 3.00 NC GR5 ZP	4
30	306095	WLDMT-GEARBOX BRACE	1
31	306096	PLATE-GEARBOX BRACE BACKING	2
32	1011600	BOLT-HEX: .38 X 1.00 NC GR5 ZP	4
33	1016999	NUT-TOPLOCK: .38 NC GR5 ZP	4

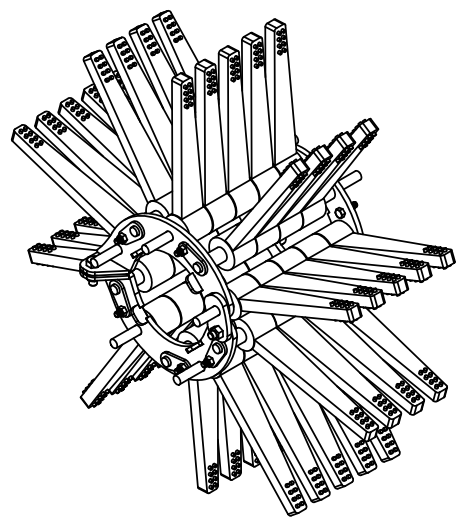
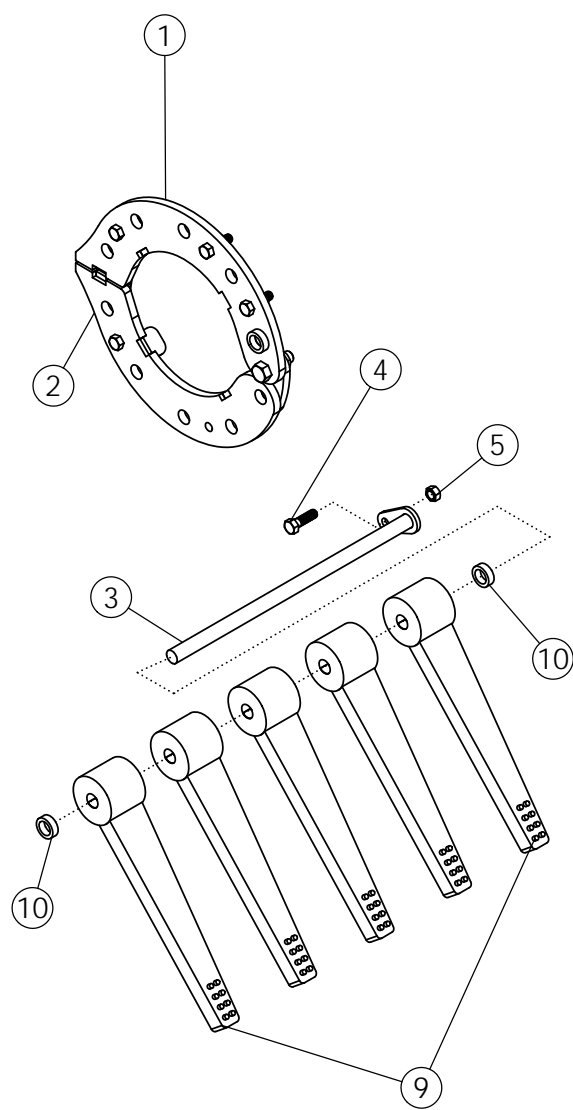
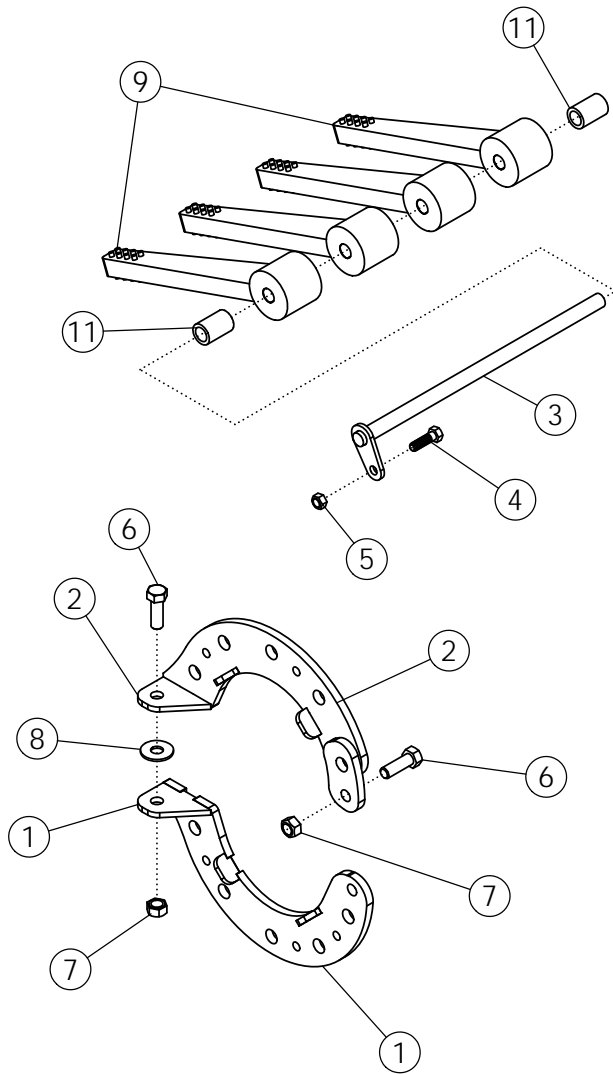

ASSY-FLAIL #2 10 ROD #305696

ITEM	PART NO.	DESCRIPTION	QTY
1	305522	WLDMT-FLAIL RING 10 ROD	2
2	305523	WLDMT-FLAIL RING 10 ROD	2
3	305499	WLDMT-10 FLAIL ROD	10
4	1011601	BOLT-HEX: .38 X 1.25 NC GR5 ZP	10
5	1016999	NUT-TOPLOCK: .38 NC GR5 ZP	10
6	1011607	BOLT-HEX: .50 x 1.50 NC GR5 ZP	4
7	1027461	NUT-TOPLOCK: .50 NC GR5 ZP	4
8	1014443	WASHER-FLAT: .50 ZP	2
9	52354	FLAIL-RUBBER 1 X 12 (PREMIER)	45
10	51547	SPACER-SHORT	10
11	51548	SPACER-LONG	10

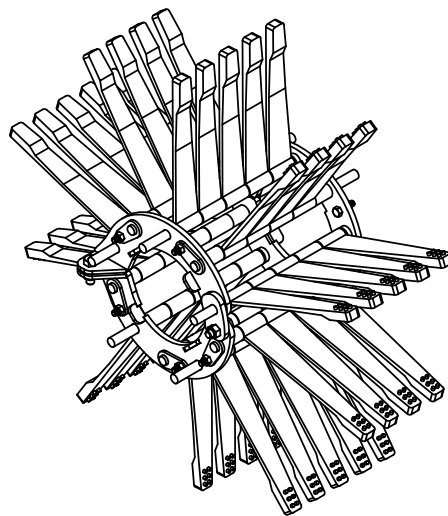
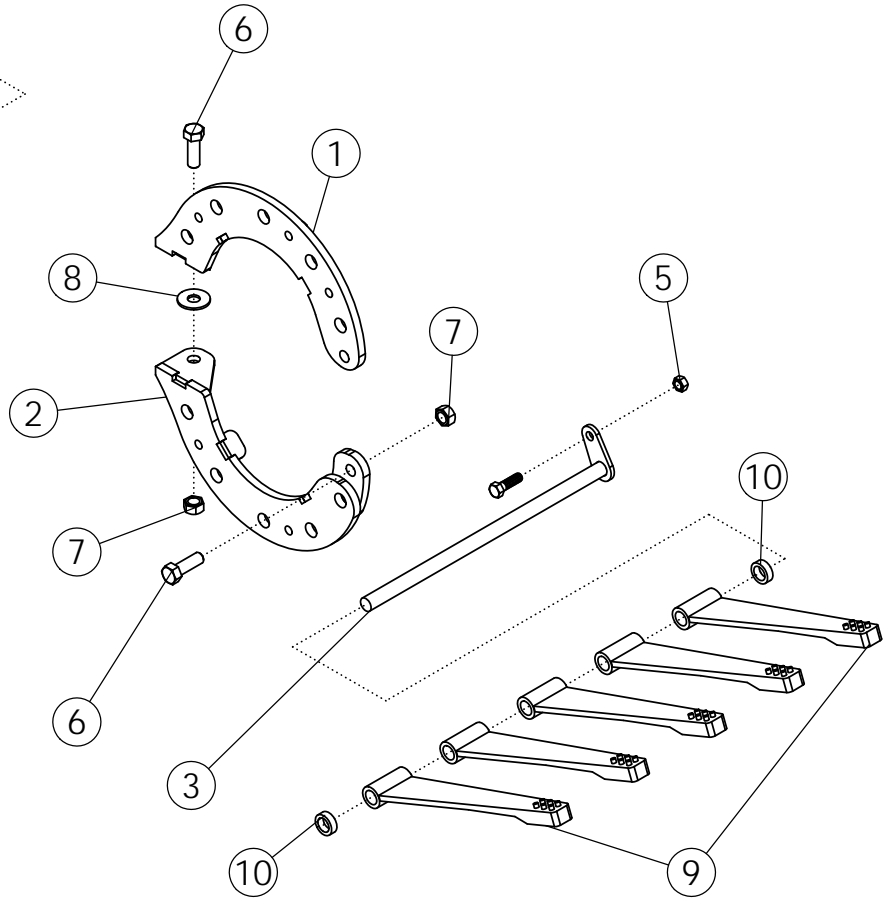
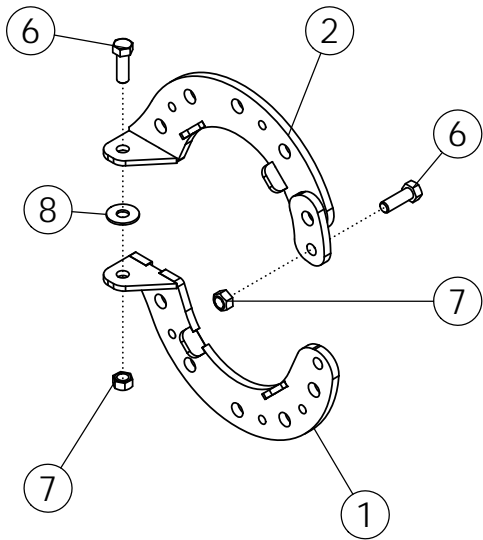
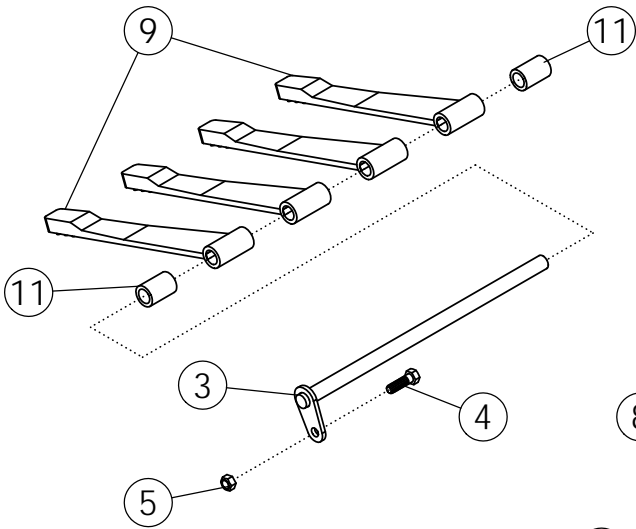

ASSY FLAIL #2 ROD #305776

ITEM	PART NO.	DESCRIPTION	QTY
1	305522	WLDMT-FLAIL RING 10 ROD	2
2	305523	WLDMT-FLAIL RING 10 ROD	2
3	305499	WLDMT-10 FLAIL ROD	10
4	1011601	BOLT-HEX: .38 X 1.25 NC GR5 ZP	10
5	1016999	NUT-TOPLOCK: .38 NC GR5 ZP	10
6	1011607	BOLT-HEX: .50 x 1.50 NC GR5 ZP	4
7	1027461	NUT-TOPLOCK: .50 NC GR5 ZP	4
8	1014443	WASHER-FLAT: .50 ZP	2
9	52356	FLAIL-STUDDDED 1 X 12	45
10	51547	SPACER-SHORT	10
11	51548	SPACER-LONG	10

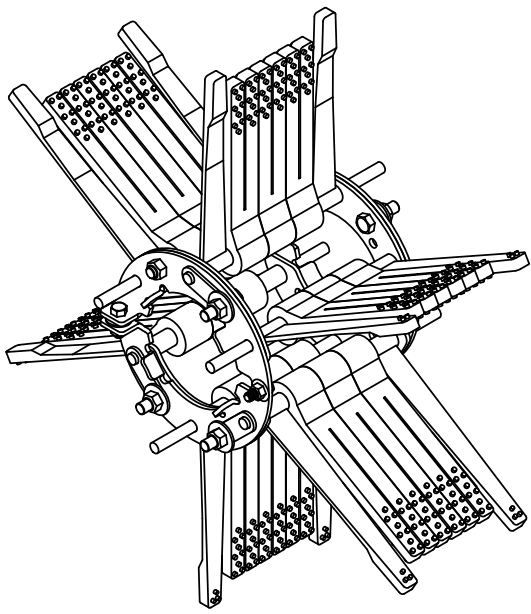
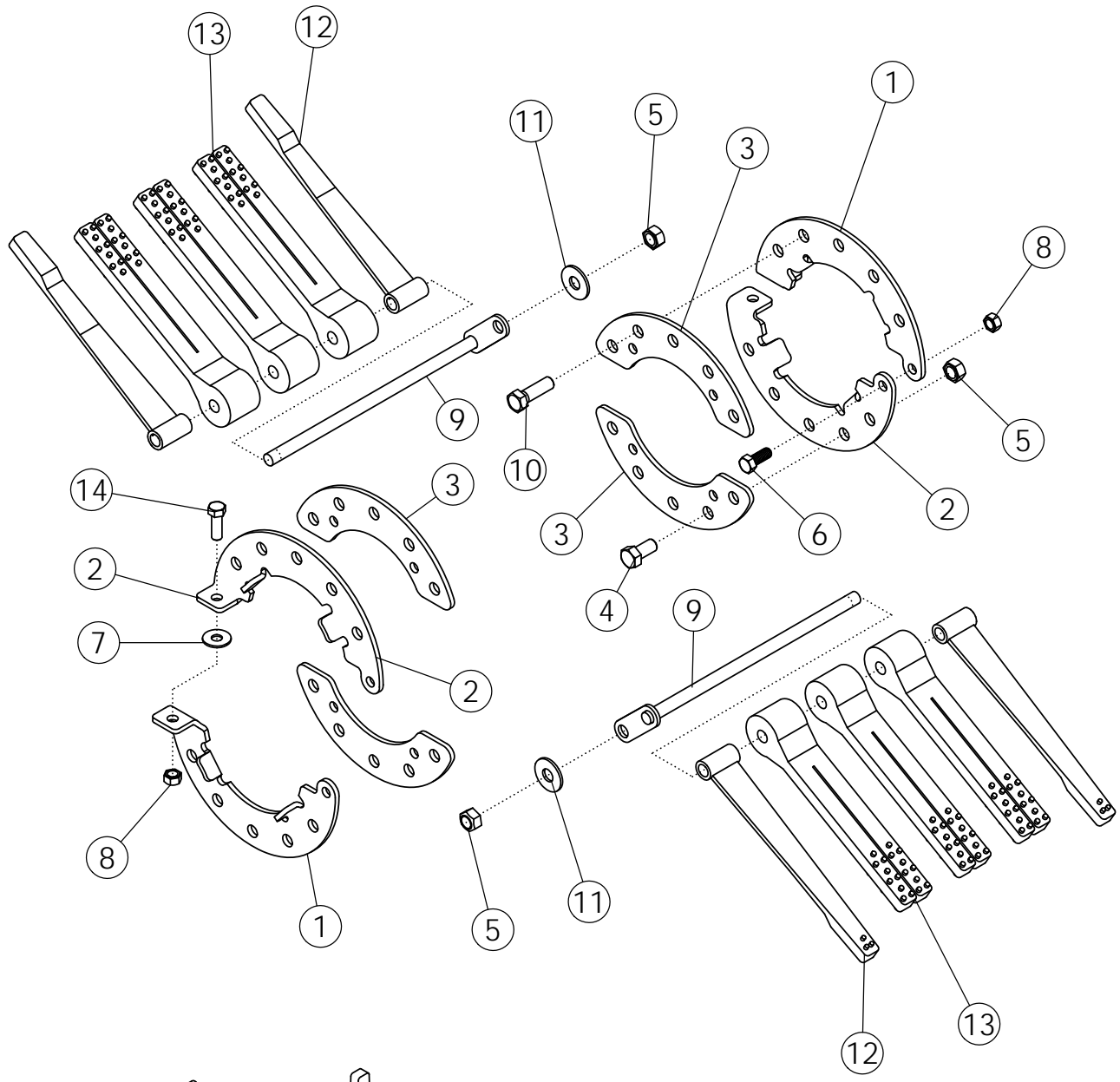

FLAILS ON #3 DRUM

ITEM	PART NO.	DESCRIPTION	QTY
1	52062	FLAIL RING-LH	2
2	52061	FLAIL RING-RH	2
3	58084	PLATE-REINFORCEMENT ZP	4
4	1032509	BOLT-HEX: .63 X 1.25 NC GR5 ZP	2
5	1016595	NUT-TOPLOCK: .63 NC GR5 ZP	8
6	1011606	BOLT-HEX: .50 X 1.25 NC GR5 ZP	2
7	1014443	WASHER-FLAT: .50 ZP	2
8	1027461	NUT-TOPLOCK: .50 NC GR5 ZP	4
9	305557	FLAIL ROD	6
10	1011623	BOLT-HEX: .63 X 2.00 NC GR5 ZP	6
11	1013024	WASHER-FLAT: .63 ZP	6
12	52355	FLAIL-SWEEP 1 X 13-1/4	12
13	58255	FLAIL-SPLIT TAPER 2 X 12	18
	52356	FLAIL-STUDDER 1 X 12	18
14	1011607	BOLT-HEX: .50 X 1.50 NC GR5 ZP	2

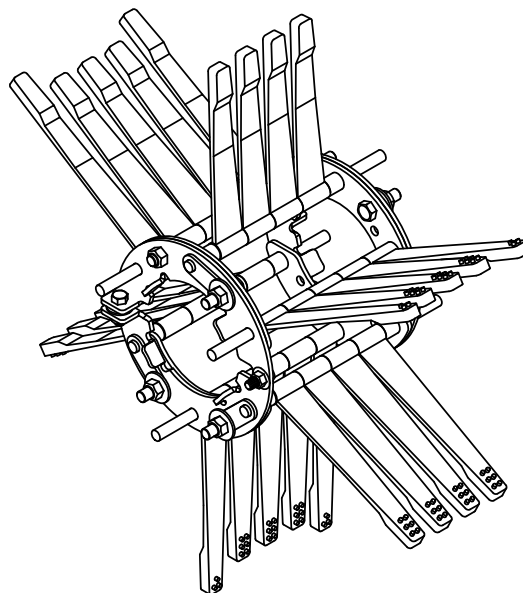
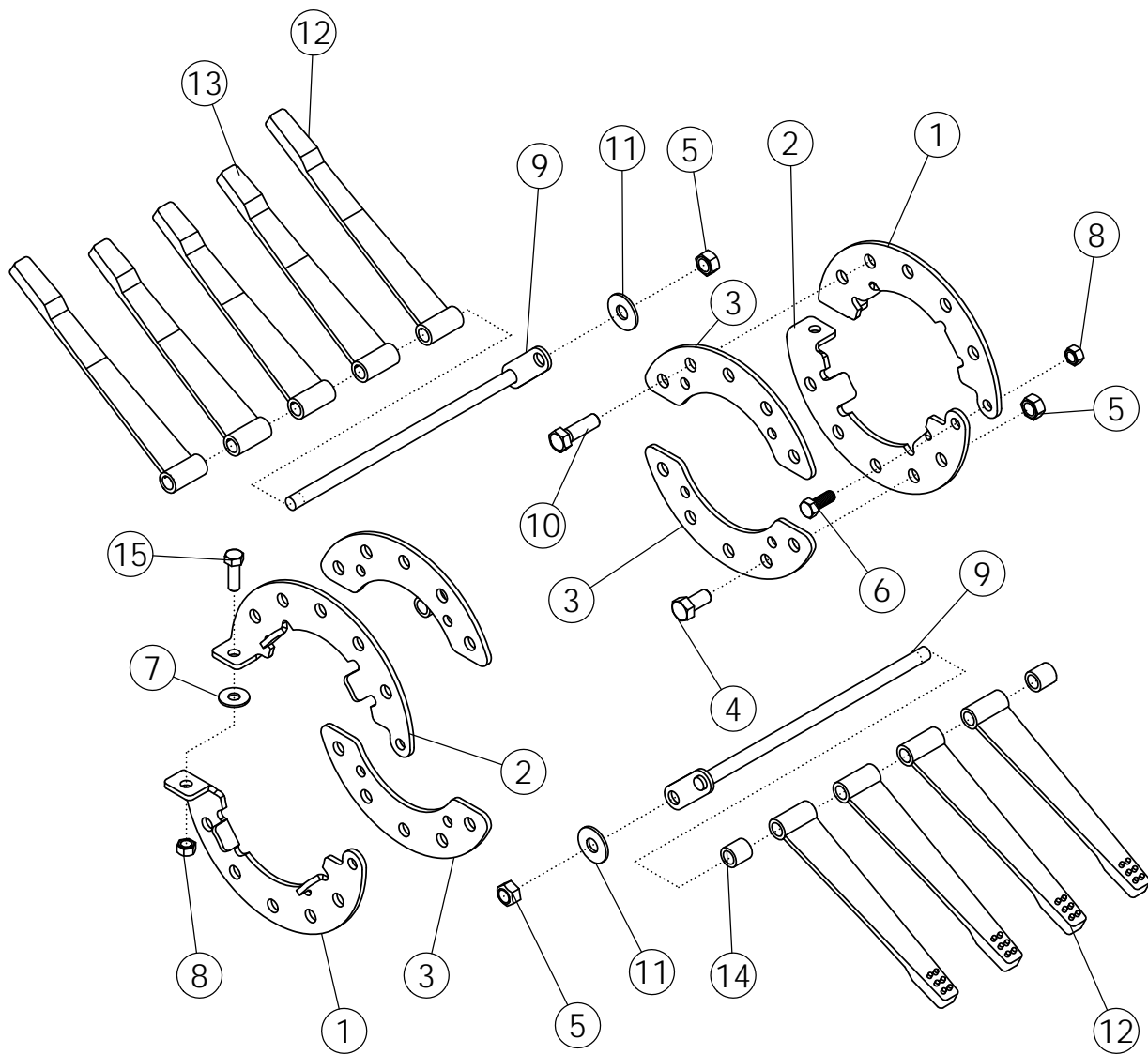

FLAILS ON #3 DRUM

ITEM	PART NO.	DESCRIPTION	QTY
1	52062	FLAIL RING-LH	2
2	52061	FLAIL RING-RH	2
3	58084	PLATE-REINFORCEMENT ZP	4
4	1032509	BOLT-HEX: .63 X 1.25 NC GR5 ZP	2
5	1016595	NUT-TOPLOCK: .63 NC GR5 ZP	8
6	1011606	BOLT-HEX: .50 X 1.25 NC GR5 ZP	2
7	1014443	WASHER-FLAT: .50 ZP	2
8	1027461	NUT-TOPLOCK: .50 NC GR5 ZP	4
9	305557	FLAIL ROD	6
10	1011623	BOLT-HEX: .63 X 2.00 NC GR5 ZP	6
11	1013024	WASHER-FLAT: .63 ZP	6
12	52355	FLAIL-SWEEP 1 X 13-1/4	6
13	52354	FLAIL-RUBBER 1 X 12 (PREMIER)	21
14	51548	SPACER 1"	6
15	1011607	BOLT-HEX: .50 X 1.50 NC GR5 ZP	2

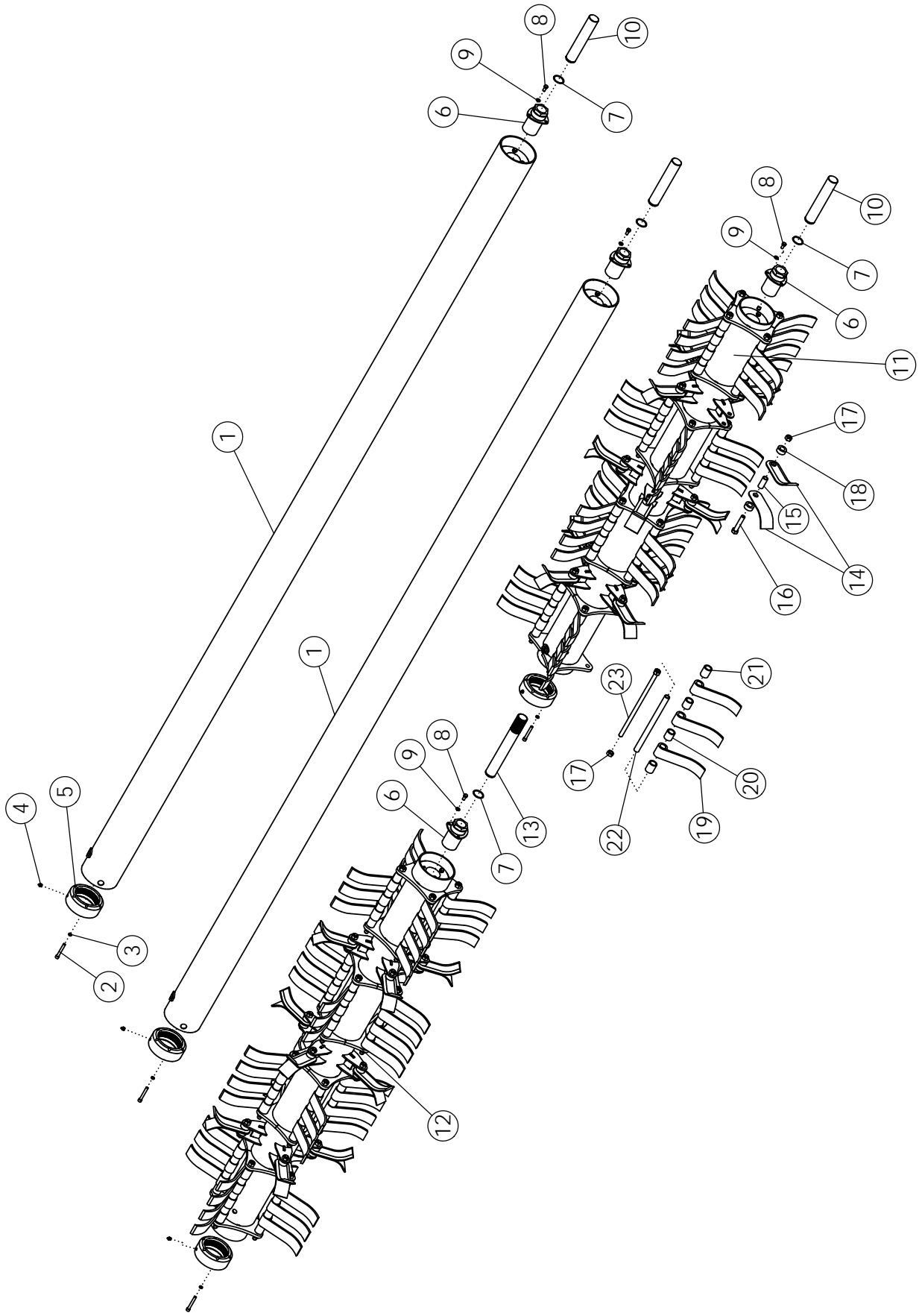

FLAIL TUBE ASSEMBLY

ITEM	PART NO.	DESCRIPTION	QTY
1	68490*	FLAIL TUBE - 0822 TT (COMPLETE)	2
2	68417	SCREW: S-H-CAP .38 X 2.75 NC	24
3	68418	WASHER-LOCK: .38 HIGH COLLAR	24
4	1030766	ZERK-GREASE: .13 NPT	4
5	68412	DRIVE SLEEVE	4
6	64163	TRANTORQUE: 1.750" X 3.375"	4
7	64184	RING-RETAINING 1.750"	4
8	1011599	BOLT-HEX: .38 X .75 NC GR5 ZP	12
9	1011586	WASHER-LOCK: .38 ZP	12
10	68445	SHAFT-IDLER	3
11	305889	ASSY-STL DRUM LH 822 HS (COMPLETE)	1
	305875	ASSY-STL DRUM LH 630 HS (COMPLETE)	
	305821	ASSY-STL DRUM LH 626 HS (COMPLETE)	
12	305888	ASSY-STL DRUM RH 822 HS (COMPLETE)	1
	305874	ASSY-STL DRUM RH 630 HS (COMPLETE)	
	305861	ASSY-STL DRUM RH 626 HS (COMPLETE)	
13	68442	SHAFT-SPLINED COUPLING	1
14	58680	FLAIL-STEEL	32-48
15	68427	BUSHING-L KNIFE	16-24
16	65825	BOLT-HEX: .63 X 3.25 NC GR5 ZP	16-24
17	1016595	NUT-TOPLOCK: .63 NC GR5 ZP	40-56
18	68426	SPACER- L KNIFE	32-48
19	68479	FLAIL-CUP 8"	84-112
20	68546	SPACER 1.45"	60-80
21	68547	SPACER 1.70"	24-32
22	305503	BUSHING-FLAIL 12.688"	24-32
23	305502	WLDMT-FLAIL ROD CUP 15.625"	24-32

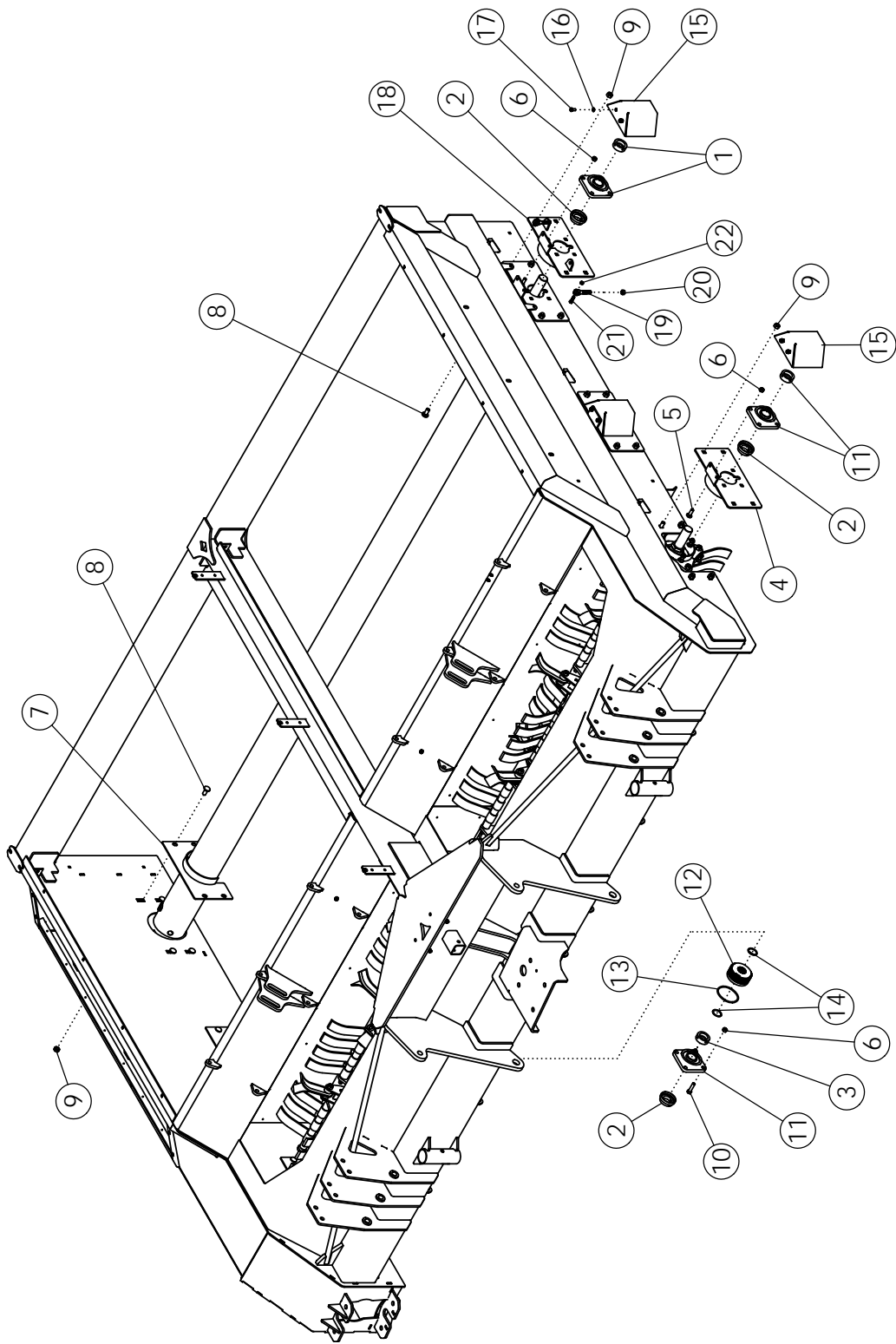

FLAIL TUBE MOUNTING

ITEM	PART NO.	DESCRIPTION	QTY
1	52404	BEARING-FLANGE 1.75	4
2	52382	SEAL PROTECTOR 1.75	6
3	52383*	LOCK PROTECTOR 1.75	3
4	68244	WLDMT-BEARING PLATE	3
5	1011660	BOLT-CRG: .50 X 1.50 NC GR5 ZP	12
6	1027461	NUT-TOPLOCK: .50 NC GR5 ZP	24
7	51809	WLDMT-SHIELD ANTI WRAP NARROW	3
8	72063	BOLT-CRG: .63 X 1.50 NC GR5 ZP	24
9	1016595	NUT-TOPLOCK: .63 NC GR5 ZP	24
10	1011609	BOLT-HEX: .50 X 2.00 NC GR5 ZP	12
11	63506	BEARING-FLANGE 1.75 N-SEAL	2
12	68413	COUPLER-DRIVE	6
13	68414	O-RING 70 BUNA	6
14	68415	SNAP RING	12
15	68462	WLDMT-IDLER SHIELD	3
16	1011586	WASHER-LOCK: .38	6
17	1011599	BOLT-HEX: .38 X .75 NC GR5 ZP	6
18	305624	WLDMT-BEARING PLATE ADJ	1
19	305614	BOLT-CLEVIS .50"	4
20	1011500	NUT-CENTERLOCK: .50 NC GR2 ZP	4
21	1011601	BOLT-HEX: .38 X 1.25 NC GR5 ZP	4
22	1016999	NUT-TOPLOCK: .38 NC GR5 ZP	4

* Replaces lock collar provided with bearing for the center

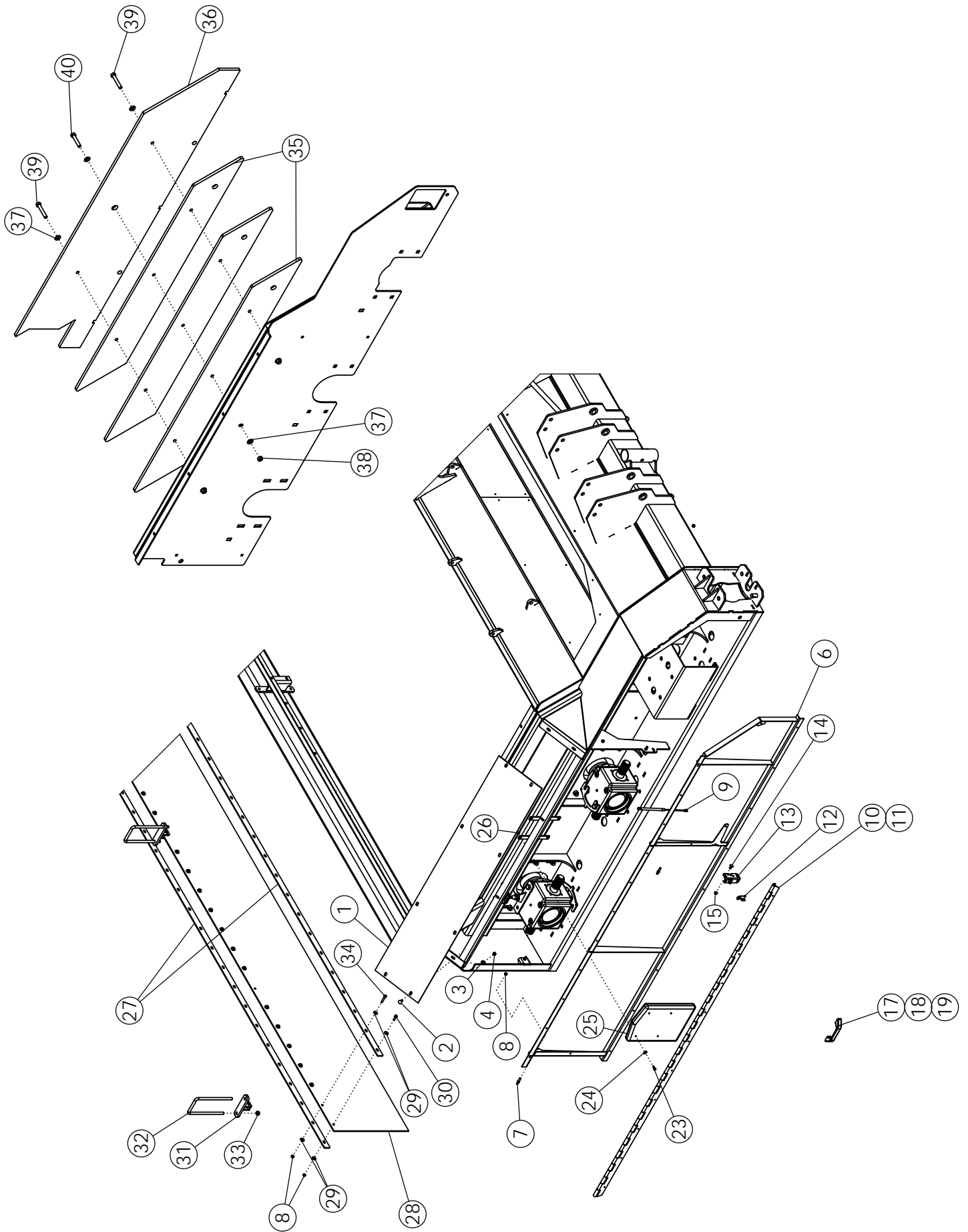

SIDE DOOR AND SHIELDS

ITEM	PART NO.	DESCRIPTION	QTY
1	305233	SHEET-TOP SHIELD	1
2	59488	BOLT-CRG: .38 X 1.00 C R5 ZP	8
3	1011282	WASHER-FLAT: .38 ZP	8
4	1016999	NUT-TKOPLOCK: .38 NC GR5 ZP	8
5	305234	SHEET-DIDE DOOR 12R	1
6	305235	WLDMT-DOOR FRAME 12R	1
7	69278	STUD-BALL 5/16-18 NC X .75	4
8	1030700	NUT-TOPLOCK: .31 NC GR5 ZP	50
9	305225	SPRING-GAS SHOCK 150LB 8" STROKE	2
10	305224	HINGE-HEAVY CONTINUOUS	1
11	1011974	RIVET-POP: .19 X .550 ZP	34
12	69284	LEVER-HRV LATCH ZP	1
13	69283	LATCH -ROTARY	1
14	65702	BOLT-CRG: .31 X 0.75 NC GR5 ZP	2
15	67077	NUT-FLANCE: SERR .31 NC ZP GR2	4
16	1029448	BOLT-HEX: .31 X 3.00 NC GR5 ZP	1
17	69285	HANDLE-MOLDED GRAB	1
18	67078	SCREW-P-H: 10-24 X .75 N CGR2 ZP	2
19	1026591	NUT-K-LOCK: 10-24 N CGR2 ZP	2
20	68324	PLATE-DEF MANUAL CASE	1
21	68602	BOLT-CRG: .25 X .75 NC GR5 ZP	4
22	1030946	NUT-TOPLOCK: .25 NC GR5 ZP	4
23	1011595	BOLT-HEX: .25 X .75 NC GR5 ZP	4
24	1020416	WASHER-FLAT: .25 ZP	4
25	64635	CASE-MANUAL STORAGE	1
26	1030946	NUT-TOPLOCK: .25 NC GR5 ZP	
27	63447	BAR-REAR FLAP 0822, 0630	4
28	52358	FLAP-REAR 0822, 0630	2
29	1011583	WASHER-FLAT: .31 ZP	52
30	1011598	BOLT-HEX: .31 X 1.00 NC GR5 ZP	26
31	63448	WLDMT-REAR FLAP MOUNT	4
32	63458	U-BOLT: .500 X 9.25 X 4 X 9.25	4
33	1027461	NUT-TOPLOCK: .50 NC GR5 ZP	8
34	1013424	BOLT-HEX: .31 X 1.75 NC GR5 ZP	4
35	305789	PLATE-WEIGHT DEF	3
	306235	PLATE-WEIGHT DEF SPLIT-FRAME	
36	305798	PLATE-WEIGHT OUTER DEF	1
37	1013004	WASHER-FLAT: SAE .63 ZP	6
38	1016595	NUT-TOPLOCK: .63 NC GR5 ZP	3
39	59093	BOLT-HEX: .63 x 3.75 NC GR5 ZP	2
40	65825	BOLT-HEX: .63 X 3.25 NC GR5 ZP	1

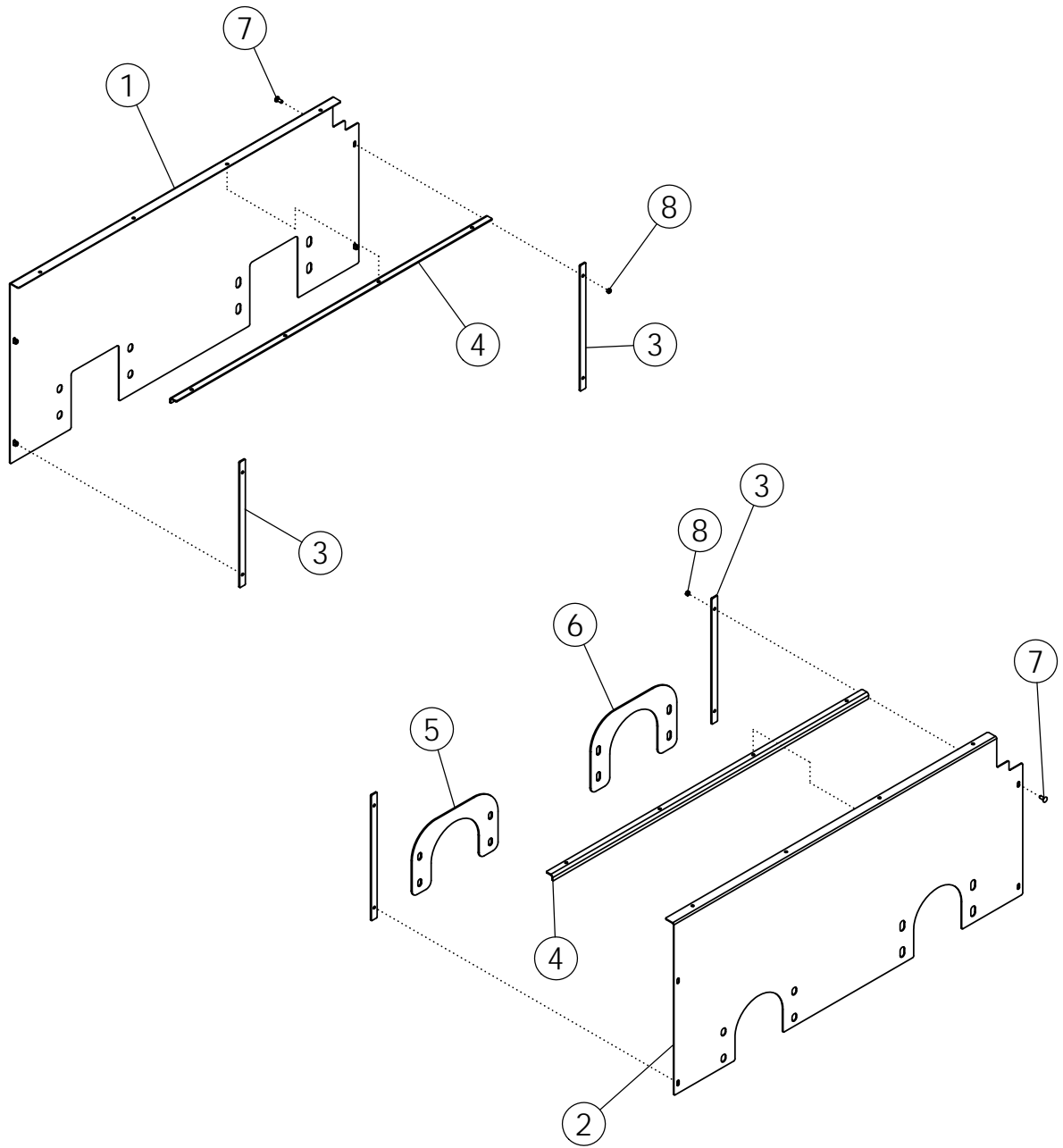

SIDE PLASTIC ASSY

ITEM	PART NO.	DESCRIPTION	QTY
1	305283	LINER-RH 3750 DEF PLASTIC	1
2	305284	LINER-LH 3750 DEF PLASTIC	1
3	69968	PLATE-RETAINER VERT	4
4	305286	PLATE- TOP RETAINER	2
5	69969	PLATE-LH LOWER RETAINER	1
6	305285	PLATE-LH LOWER REAR RETAINER	1
7	59488	BOLT-CRG: .38 X 1.00 NC GR5 ZP	16
8	1016999	NUT-TOPLOCK: .38 NC GR5 ZP	16

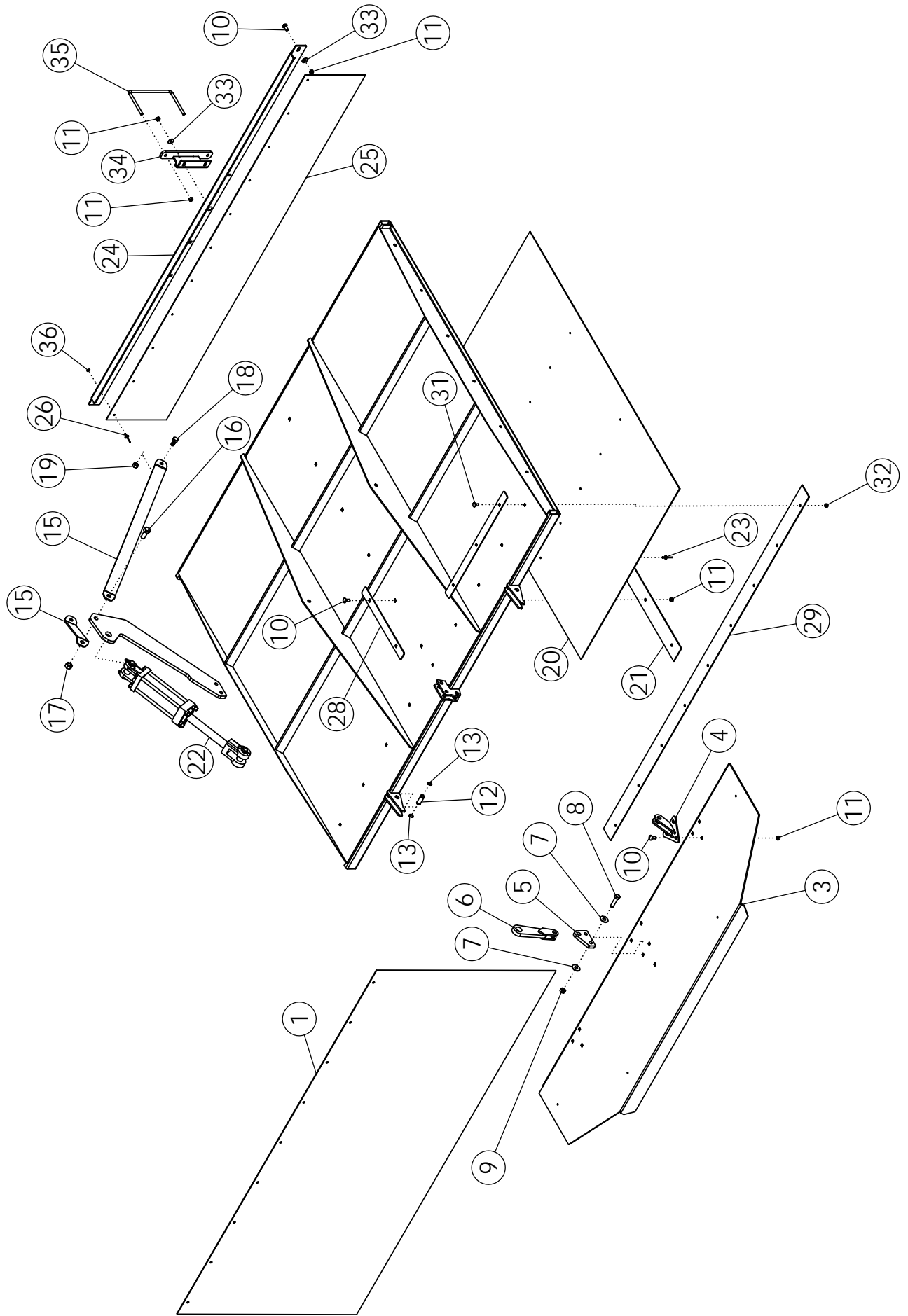

TOP DOOR ASSY

ITEM	PART NO.	DESCRIPTION	QTY
1	305486	LINER-HANGING 8R	2
2	305476	WLDMT-TOP DOOR 8R	2
3	305470	WLDMT-SHROUD DOOR 8R	2
4	305655	WLDMT-HINGE SHROUD DOOR	4
5	305771	PLATE HINGE LUG	2
6	305629	WLDMT-DOOR LINKAGE	2
7	1014443	WASHER-FLAT: .50 ZP	16
8	1011609	BOLT-HEX: .50 X 2.00 NC GR5 ZP	8
9	1027461	NUT-TOPLOCK: .50 NC GR5 ZP	8
10	59488	BOLT-CRG: .38 X 1.00 NC GR5 ZP	30
11	1016999	NUT-TOPLOCK: .38 NC GR5 ZP	58
12	305244	PIN-TOP DOOR ZP	14
13	305261	SNAP RING .625 HD EXTERNAL ZP	28
14	305253	PLATE-DOOR CYLINDER LIFT	2
15	305474	PLATE-LIFT STRAP 8R	4
16	1014349	BOLT-HEX: .63 X 1.50 NC GR5 ZP	2
17	59316	NUT-CENTERLOCK: .63 NC GR5 ZP	2
18	1011096	BOLT-HEX: .50 X 1.00 NC GR5 ZP	4
19	1011500	NUT-TOPLOCK: .50 NC GR5 ZP	4
20	305475	PLASTIC-TOP DOOR 8R	4
21	305247	PLATE-PLASTIC RETAINER CENTER	2
22	58890	CYLINDER HYDRAULIC 3 X 8	2
23	56886	RIVET-POP: .19 X .675 ZP	40
24	305488	PLATE-REAR SUPPORT 8R	2
25	305487	LINER-REAR 8R	2
26	1011974	RIVET-POP: .19 X .531 ZP	22
27	305248	PLATE-PLASTIC RETAINER SIDE	4
28	305484	PLATE-BACKING CENTER 8R	6
29	305482	PLATE-LINER BOLTING 8R	2
30	305483	PLATE-BACKING FRONT 8R	6
31	65702	BOLT-CRG: .31 X .75 NC GR5 ZP	18
32	1030700	NUT-TOPLOCK: .31 NC GR5 ZP	18
33	1011828	WASHER-FLAT .38 ZP	6
34	69111	WLDMT-DOOR SUPPORT	2
35	64244	U-BOLT: .375 X 5.13 X 8.00 X 5.13	2
36	306105	WASHER-RIVET BLIND .19"	22

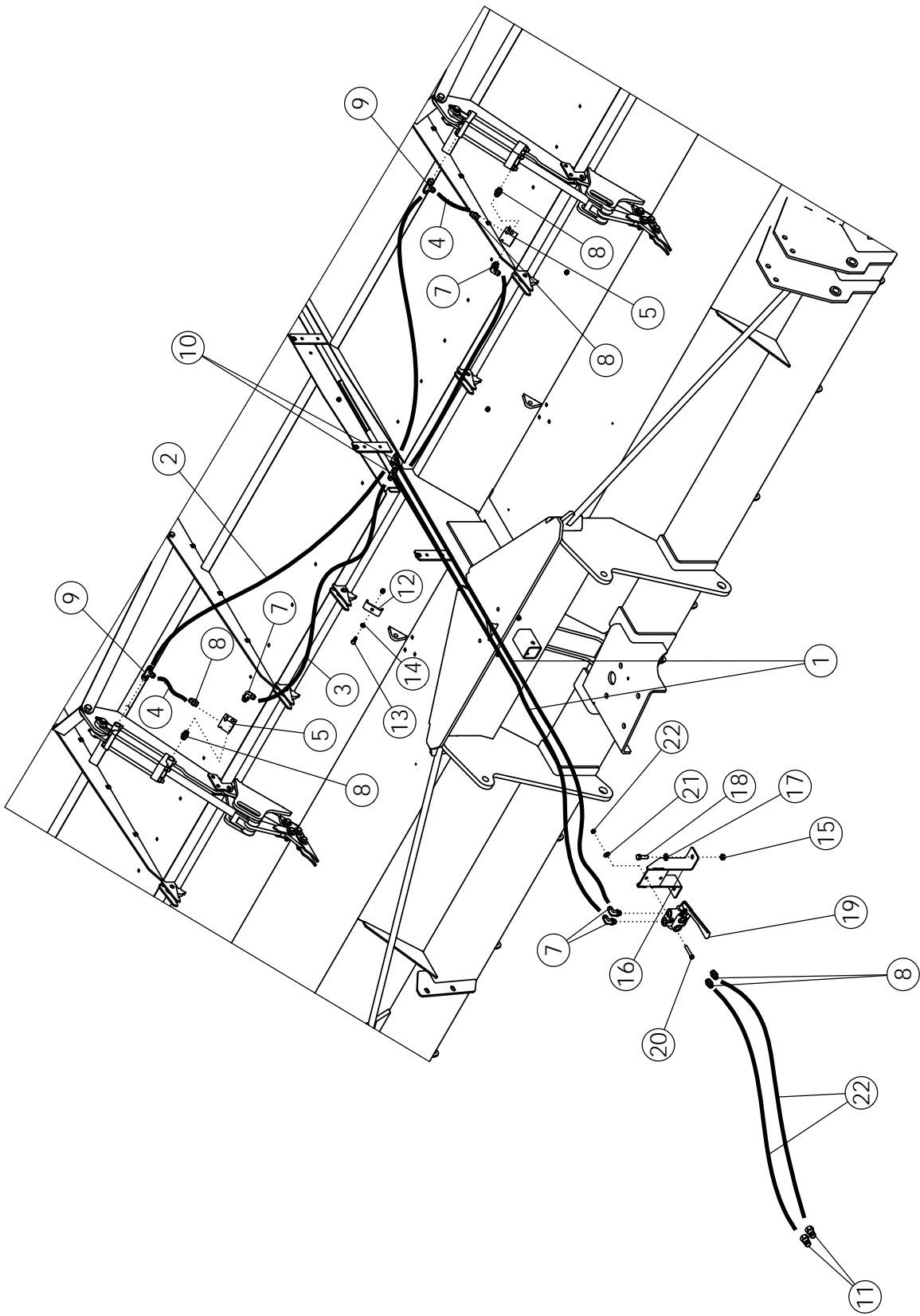

TOP DOOR HYDRAULICS

ITEM	PART NO.	DESCRIPTION	QTY
1	72745	HOSE: .38 X 30 8MB-8FJX	2
2	305636	HOSE: .38 X 82 8FJX-8FJX	2
3	305637	HOSE: .38 X 72 8FJX-8FJX	2
4	305345	HOSE: .38 X 8.25 8FJX-8FJX	2
5	305404	VALVE-CHECK SINGLE PILOT OPERATED	2
6	305343	FTG-ADAPTER: 8MB-8MB	2
7	58560	FTG-ELBOW: 8MB-8MJ-90	2
8	56226	FTG-ADAPTER: 8MB-8MJ	4
9	63015	FTG-TEE: 8MJ-8FJX-8MJ	2
10	57667	FTG-TEE: 8MJ-8MJ-8MJ	2
11	36290	PIONEER TIP 8010-15P (#8 ORB)	2
12	50714	CLAMP 1/2" ZP	4
13	1011601	BOLT-HEX: .38 X 1.25 NC GR5 ZP	4
14	1011586	WASHER-LOCK: .38 ZP	4
15	1027461	NUT-TOPLOCK: .50 NC GR5 ZP	2
16	305794	WLDMT-SELECTOR MOUNT	1
17	1011584	WASHER-FLAT: SAE .50 ZP	1
18	1011607	BOLT-HEX: .50 X 1.50 NC GR5 ZP	2
19	58470	VALVE-SELECTOR PAINTED	1
20	59390	BOLT-HEX: .38 X 2.25 NC GR5 ZP	2
21	1011828	WASHER-FLAT .38 ZP	2
22	300353	HOSE: .50 X 108 8MB-8FJX	2

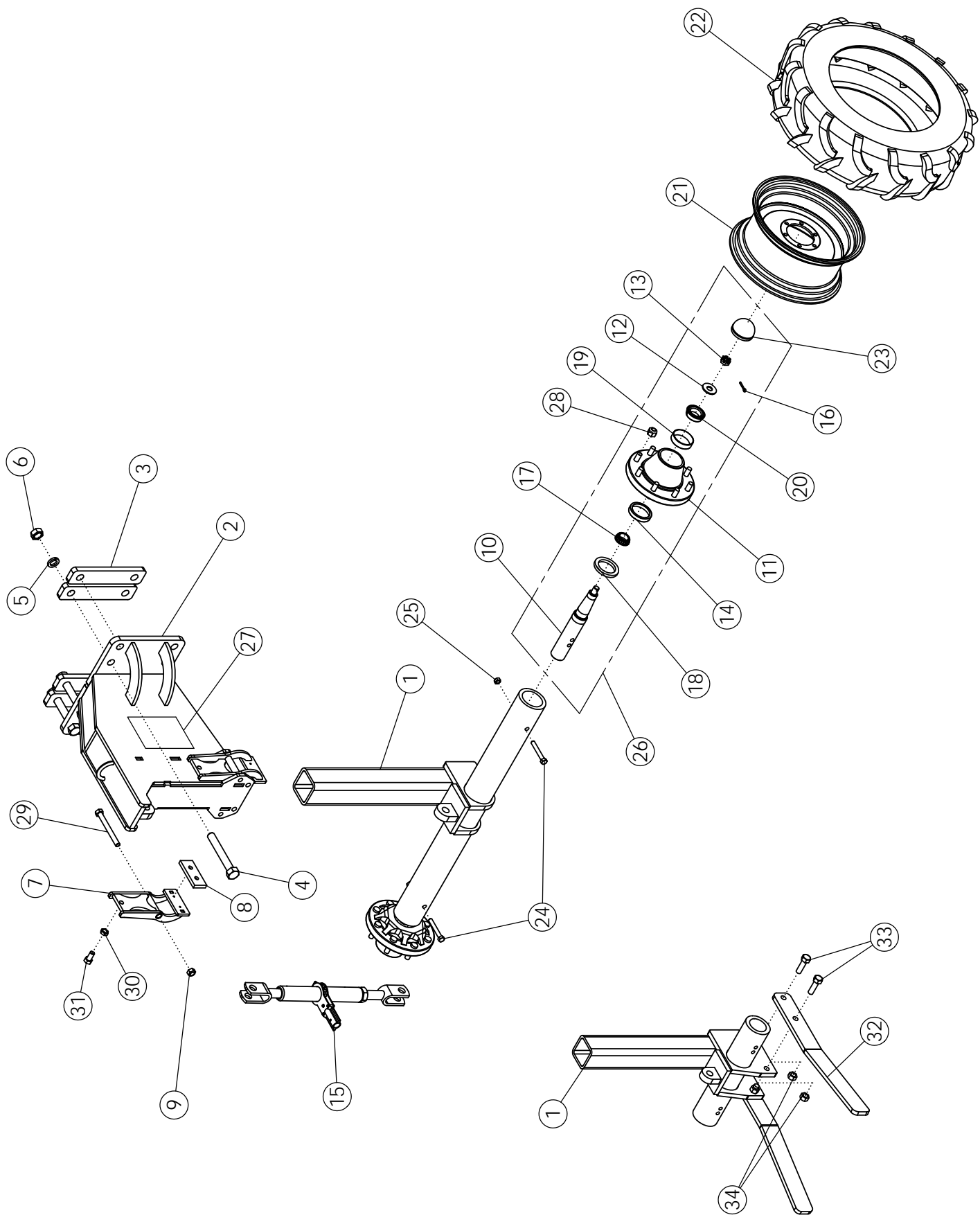

STANDARD REAR STRUTS - 11.2 X 24 TIRES

ITEM	PART NO.	DESCRIPTION	QTY
1	68331	WLDMT-SPINDLE HOUSING (44")	1
	68236	WLDMT-SPINDLE HOUSING (NARROW)	1
	68766	WLDMT-SPINDLE HOUSING- 6" OFFSET RH	1
	68767	WLDMT-SPINDLE HOUSING- 6" OFFSET LH	1
	69434	ASSY-OSC SPINDLE HOUSING (44")	1
2	68332	WLDMT-STD STRUT UPPER	1
3	58408	BAR - BOLTING	4
4	1018839	BOLT-HEX: 1.00 X 7.00 NC GR8 ZP	8
5	1013539	WASHER-LOCK: 1.00 ZP	8
6	1012664	NUT-HEX: 1.00 NC GR2 ZP	8
7	69956	WLDMT- DEF STRUT CLAMP	2
8	69971	PLASTIC-STRUT CLAMP	2
9	1016595	NUT-TOPLOCK: .63 NC GR5 ZP	2
10	52954*	SPINDLE	2
11	53623*	HUB-WHEEL 8-BOLT	2
12	1030728*	WASHER-FLAT: .SAE 1.000 ZP	2
13	1030726*	NUT-SPINDLE: 1.00 NF	2
14	53622*	BEARING CUP INNER	2
15	52407	RATCHET JACK-PAINTED	1
16	1030797*	PIN-COTTER: .19 X 1.75 NP	2
17	53621*	BEARING CONE INNER	2
18	53619*	SEAL	2
19	52243*	BEARING CUP OUTER	2
20	53620*	BEARING CONE OUTER	2
21	56903	WHEEL W10 X 24 8 BOLT	2
22	56976	TIRE 11.2-24 10 PLY R1	2
	68973	TUBE-REPAIR 11.2-24 (NOT SHOWN)	AR
23	53624*	CAP-HUB	2
24	1011618	BOLT-HEX: .50 X 5.00 NC GR5 ZP	2
25	1027461	NUT-TOPLOCK: .50 NC GR5 ZP	2
26	53167	ASSY HUB & SPINDLE	2
27	52248	DECAL-CAUTION	1
28	53625*	NUT-WHEEL: .63-18NF	16
29	1013068	BOLT-HEX .63 X 6.00 NC GR5 ZP	2
30	66336	NUT-JAM: .63 NF GR2 ZP	2
31	1030703	BOLT-HEX: .63 X 1.25 NF GR5 ZP	2
32	305640	PLATE-SCRAPER 11.2-24 DEF	2
33	1016598	BOLT- .75 X 2.50 NC GR5 ZP	4
34	1017000	NUT-TOPLOCK: .75 NC GR5 ZP	4

* Items are included in Item 26

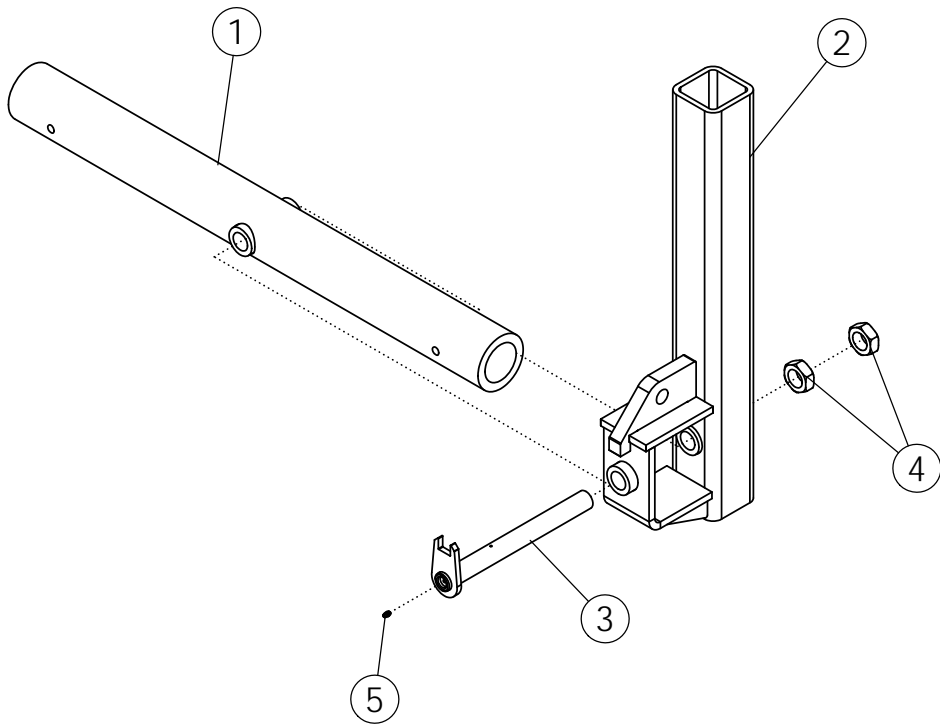

OSCILLATING SPINDLE HOUSING ASSEMBLY

ITEM	PART NO.	DESCRIPTION	QTY
1	69438	WLDMT-OSC TUBE	1
2	69444	WLDMT-OSC STRUT	1
3	69446	WLDMT-FLAG PIN ZP	1
4	65864	NUT-JAM: 1.25 NF GR2 ZP	2
5	1011748	ZERK - GREASE	1

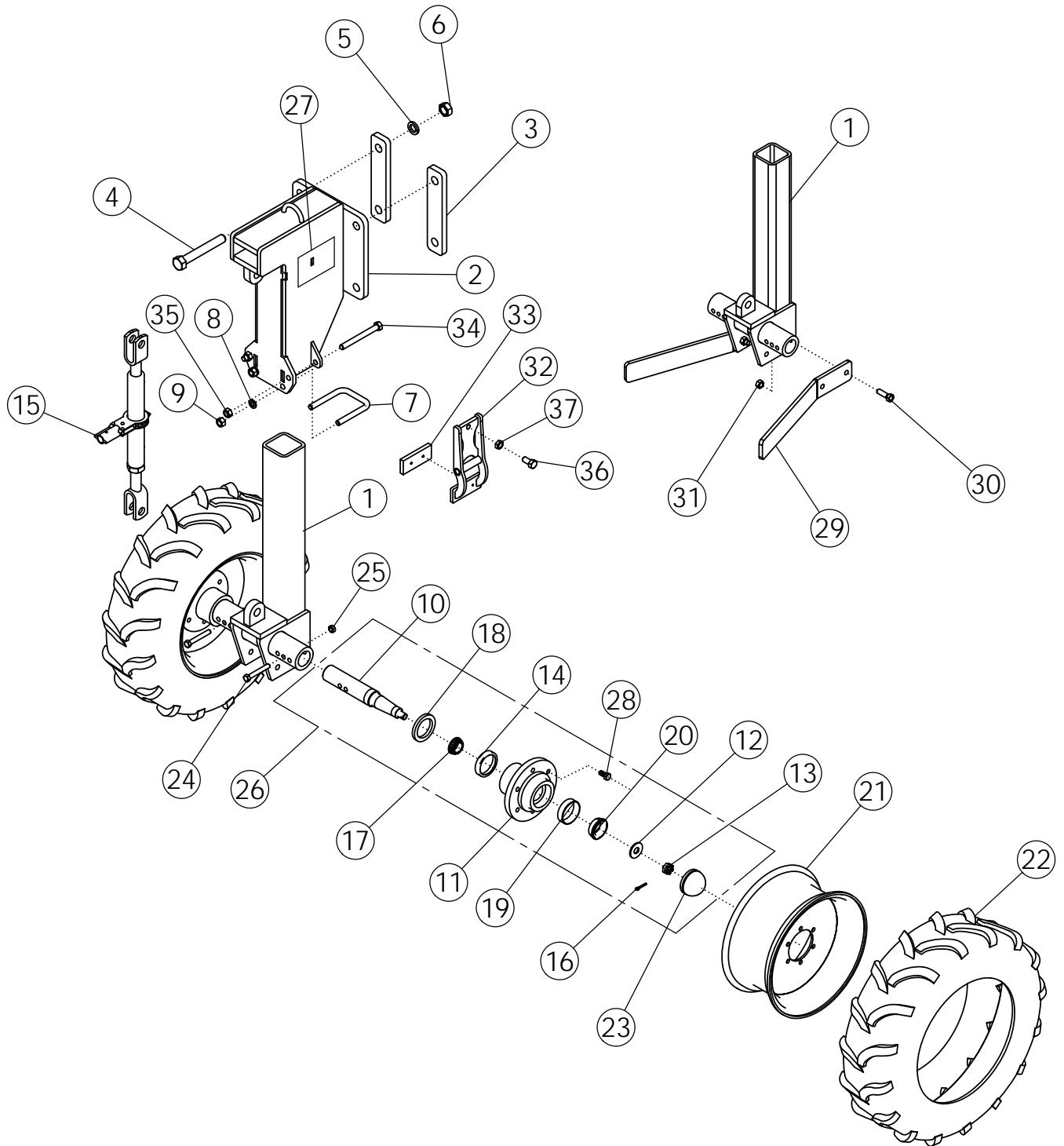

STANDARD REAR STRUTS - 7.60 X 15 TIRES

ITEM	PART NO.	DESCRIPTION	QTY
1	58281	WLDMT-SPINDLE HOUSING	1
	64402	WLDMT-SPINDLE HOUSING- 6" OFFSET RH	1
	64406	WLDMT-SPINDLE HOUSING- 6" OFFSET LH	1
2	63559	WLDMT-STD STRUT UPPER	1
3	58408	BAR - BOLTING	2
4	1018839	BOLT-HEX: 1.00 X 7.00 NC GR8 ZP	4
5	1013539	WASHER-LOCK: 1.00 ZP	4
6	1012664	NUT-HEX: 1.00 NC GR2 ZP	4
7	60547	U-BOLT: .63 X 5.25 X 4.00 X 5.25	1
8	1011813	WASHER-LOCK: .63 ZP	2
9	1011578	NUT-HEX: .63 NC GR2 ZP	2
10	52138*	SPINDLE	2
11	52247*	HUB-WHEEL 6-BOLT	2
12	1012377*	WASHER-SPINDLE: .81 X 2.00 NP	2
13	1012376*	NUT-SLOTTED: .75 NF GR5 NP	2
14	52243*	CUP-BEARING INNER	2
15	52407	RATCHET JACK-PAINTED	1
16	1012375*	PIN-COTTER: .19 X 1.50 NP	2
17	52245*	CONE-BEARING INNER	2
18	52242*	SEAL	2
19	52244*	CUP-BEARING OUTER	2
20	52246*	CONE-BEARING OUTER	2
21	52411	WHEEL 6.00-15 6 BOLT	2
22	52410	TIRE 7.60-15 I-3 6 PLY	2
	68974	TUBE-REPAIR 7.60-15 (NOT SHOWN)	AR
23	52241*	CAP-HUB	2
24	1011612	BOLT-HEX: .50 X 3.50 NC GR5 ZP	2
25	1027461	NUT-TOPLOCK: .50 NC GR5 ZP	2
26	52116	ASSY HUB & SPINDLE	2
27	52248	DECAL-CAUTION	1
28	1013426*	BOLT-LUG: .50 X 1.00 NF GR5 ZP	12
29	305642	PLATE-SCRAPER 7.6-15 DEF	2
30	1011623	BOLT-HEX: .63 X 2.00 NC GR5 ZP	4
31	1016595	NUT-TOPLOCK: .63 NC GR5 ZP	4
32	69956	WLDMT- DEF STRUT CLAMP	2
33	69971	PLASTIC-STRUT CLAMP	2
34	1013068	BOLT-HEX: .63 X 6.00 NC GR5 ZP	2
35	1016595	NUT-TOPLOCK: .63 NC GR5 ZP	2
36	1030703	BOLT-HEX: .63 X 1.25 NF GR5 ZP	2
37	66336	NUT-JAM: .63 NF GR2 ZP	2
38	69987	SCREW-MACH: FH-TORX .25-20 X 1.00 (NOT SHOWN)	4

* Items are included in Item 26

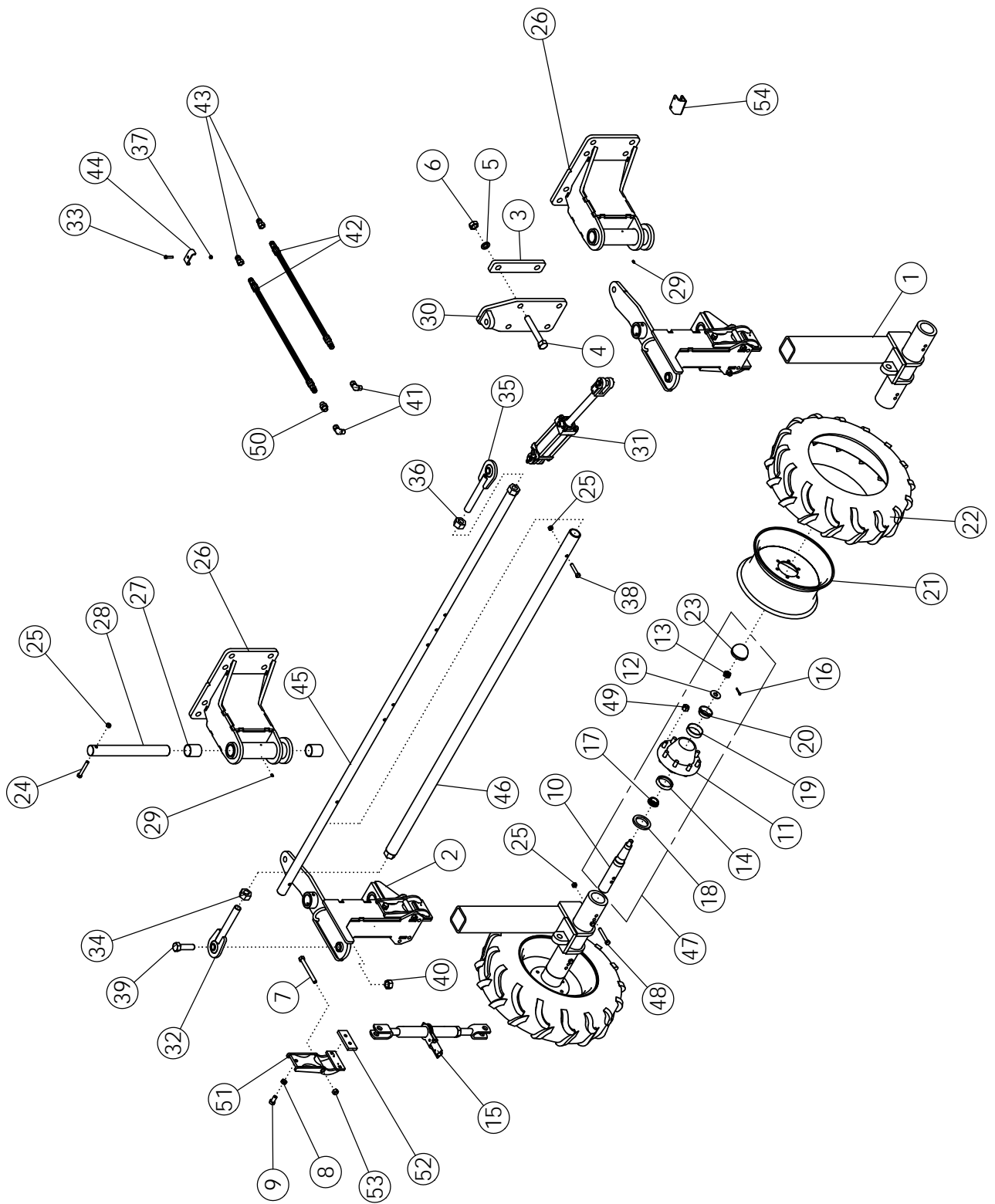

STEERABLE REAR STRUTS - 11.2 X 24 TIRES

ITEM	PART NO.	DESCRIPTION	QTY
1	68236	WLDMT-SPINDLE HOUSING (NARROW)	2
2	68237	WLDMT-STEERABLE STRUT UPPER	2
3	58408	BAR - BOLTING	10
4	1018839	BOLT-HEX: 1.00 X 7.00 NC GR8 ZP	20
5	1013539	WASHER-LOCK: 1.00 ZP	20
6	1012664	NUT-HEX: 1.00 NC GR2 ZP	20
7	1013068	BOLT-HEX .63 X 6.00 NC GR5 ZP	2
8	66336	NUT-JAM: .63 NF GR2 ZP	2
9	1030703	BOLT-HEX: .63 X 1.25 NF GR5 ZP	2
10	52954*	SPINDLE	4
11	53623*	HUB-WHEEL 8 BOLT	4
12	1030728*	WASHER-FLAT: SAE 1.00 ZP	4
13	1030726*	NUT-SPINDLE: 1.00 NF NP	4
14	53622*	BEARING CUP INNER	2
15	52407	RATCHET JACK-PAINTED	2
16	1030797*	PIN-COTTER: .19 X 1.75 NP	4
17	53621*	BEARING CONE INNER	4
18	53619*	SEAL	4
19	52243*	BEARING CUP OUTER	4
20	53620*	BEARING CONE OUTER	4
21	56903	WHEEL W10 X 24 8 BOLT	4
22	56976	TIRE 11.2-24 10 PLY R1	4
	68973	TUBE-REPAIR 11.2-24 (NOT SHOWN)	AR
23	53624*	CAP-HUB	4
24	1011612	BOLT-HEX: .50 X 3.50 GR5 ZP	2
25	1027461	NUT-TOPLOCK: .50 NC GR5 ZP	7
26	68238	WLDMT-PIVOT MOUNT	2
27	59204	BUSHING - BORED	4
28	58274	SHAFT	2
29	1011748	ZERK - GREASE	4
30	68234	WLDMT-CYLINDER BRACKET	1
31	62319	CYLINDER HYDRAULIC 2 X 4	1
	69654	SEAL KIT FOR 62319	
32	58203	WLDMT-TIE ROD END LH	1
33	1014124	BOLT-HEX: .31 X 1.50 NC GR5 ZP	2
34	1030729	NUT-HEX: 1.25 NC GR2 LH ZP	1
35	58186	WLDMT-TIE ROD END RH	1
36	1011621	NUT-HEX: 1.25 NC GR2 ZP	1
37	1030700	NUT-TOPLOCK: .31 NC GR5 ZP	2
38	1016858	BOLT-HEX: .50 X 2.75 NC GR5 ZP	1
39	1011626	BOLT-HEX: 1.00 X 3.50 NC GR5 ZP	2

CONTINUED

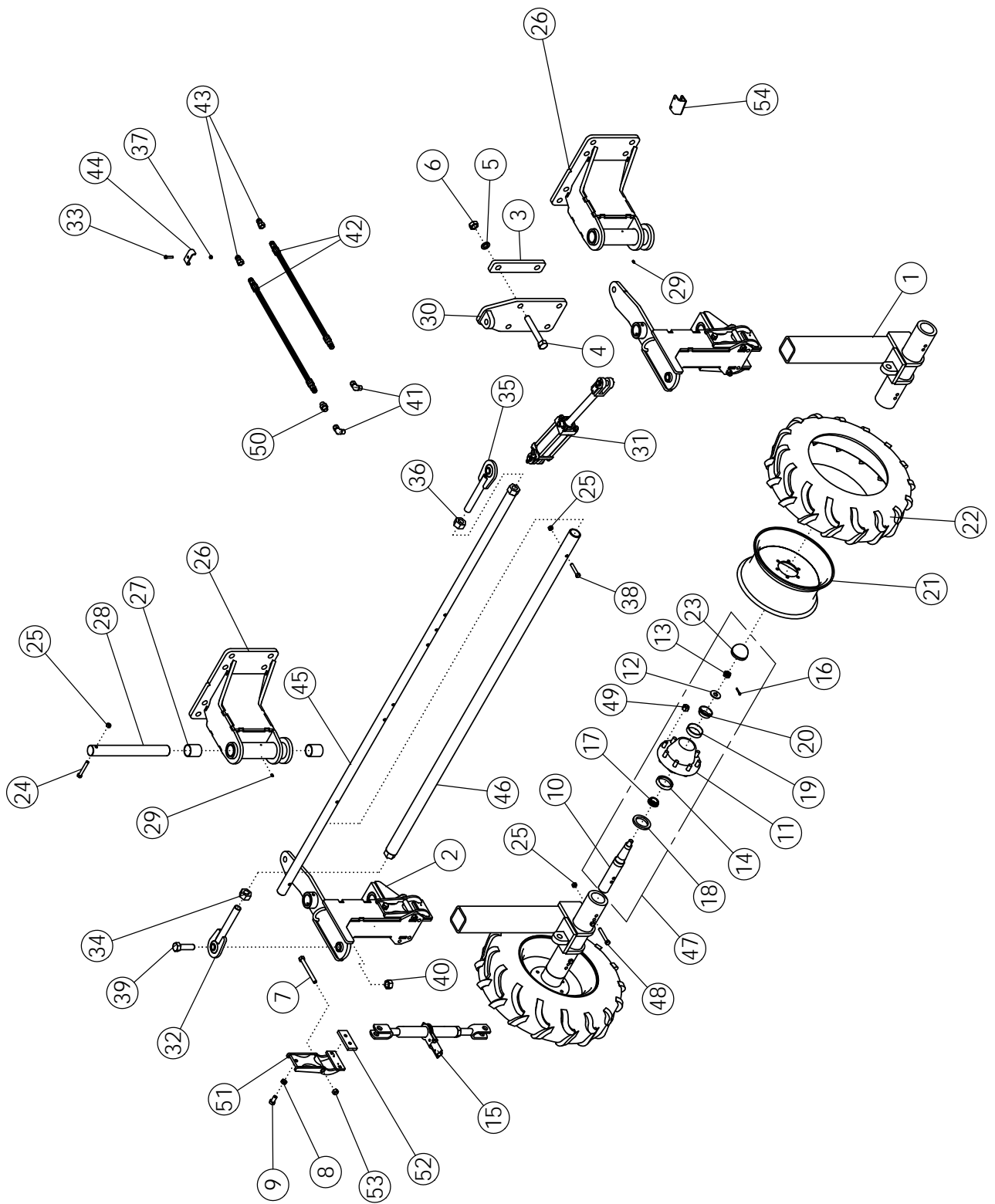

STEERABLE REAR STRUTS - 11.2 X 24 TIRES (CONTINUED)

ITEM	PART NO.	DESCRIPTION	QTY
40	1016969	NUT-TOPLOCK: 1.00 NC GR5 ZP	2
41	1026247	FTG-ELBOW: 6MP-8MJ 90	2
42	300032	HOSE: .50 X 276 8MB-8FJX	2
43	36290	PIONEER TIP 8010-15P (#8 ORB)	2
44	50714	CLAMP 1/2" ZP	2
45	58488	WLDMT-TIE ROD MALE 85"	1
46	58486	WLDMT-TIE ROD FEMALE 85"	1
47	53167	ASSY-HUB & SPINDLE	4
48	1011618	BOLT-HEX: .50 X 5.00 NCGR5 ZP	4
49	53625*	NUT-WHEEL: .63-18NF	32
50	300030	FTG-RESTRICTOR 8MJ-8FJX .062	1
51	69956	WLDMT- DEF STRUT CLAMP	2
52	69971	PLASTIC-STRUT CLAMP	2
53	1016595	NUT-TOPLOCK: .63 NC GR5 ZP	2
55	69987	SCREW-MACH: FH-TORX 1/4-20 X 1.00	4

WIDE (44")

1	68331	WLDMT-SPINDLE HOUSING (44")	2
31	58890	CYLINDER-HYDRAULIC 3 X 8	1
54	68769	WLDMT-3" CYLINDER STOP	1

* Items are included in Item 47

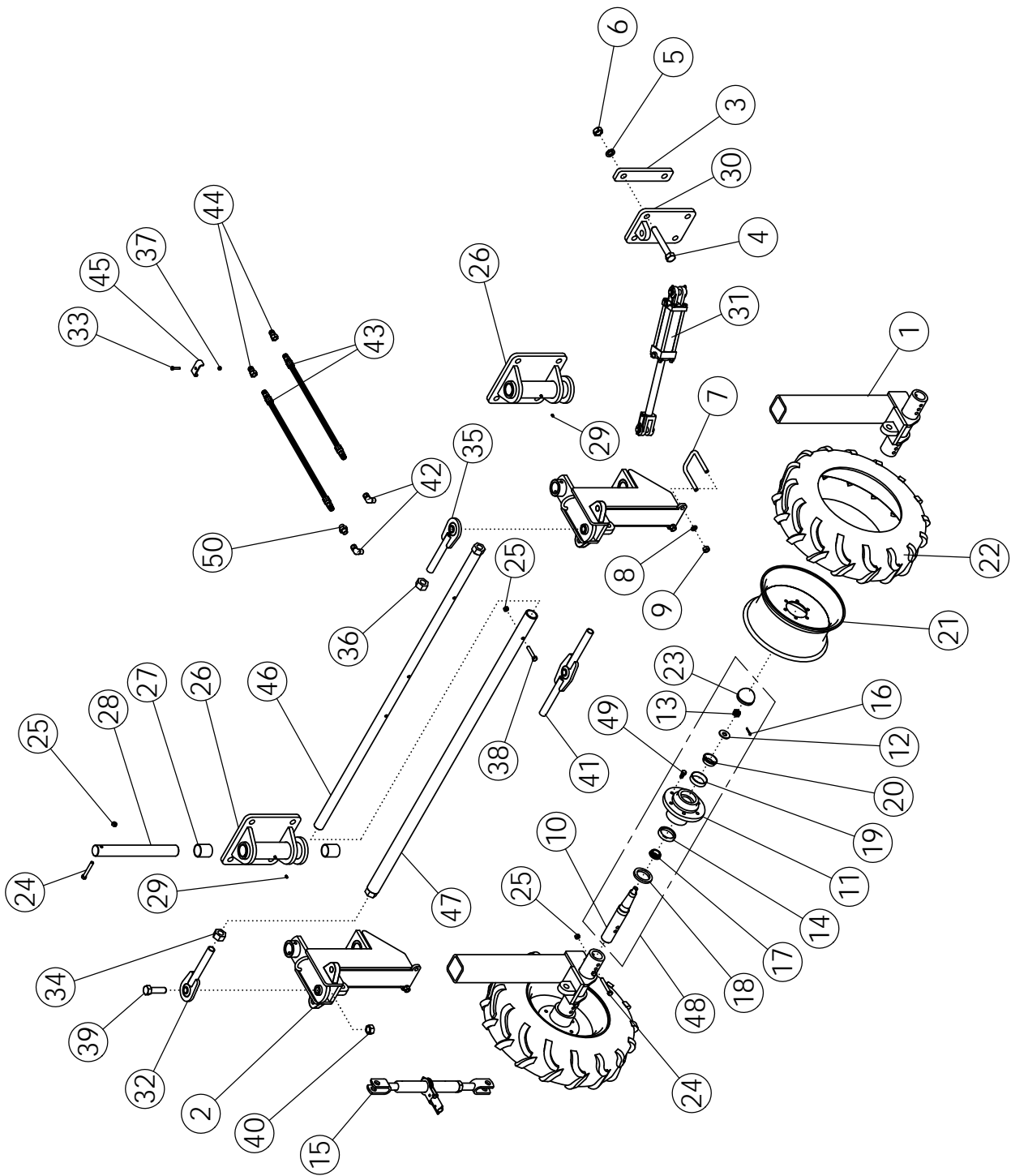

STEERABLE REAR STRUTS - 7.60 X 15 TIRES

ITEM	PART NO.	DESCRIPTION	QTY
1	58281	WLDMT-SPINDLE HOUSING	4
2	63558	WLDMT-STEERABLE STRUT UPPER	4
3	58408	BAR - BOLTING	10
4	1018839	BOLT-HEX: 1.00 X 7.00 NC GR8 ZP	20
5	1013539	WASHER-LOCK: 1.00 ZP	20
6	1012664	NUT-HEX: 1.00 NC GR2 ZP	20
7	60547	U-BOLT: .63 X 5.25 X 4.00 X 5.25	4
8	1011813	WASHER-LOCK: .63 ZP	8
9	1011578	NUT-HEX: .63 NC GR2 ZP	8
10	52138*	SPINDLE	8
11	52247*	HUB-WHEEL 6 BOLT	8
12	1012377*	WASHER-SPINDLE: .81 X 2.00 NP	8
13	1012376*	NUT-SLOTTED: .75 NF GR5 NP	8
14	52243*	BEARING CUP-INNER	8
15	52407	RATCHET JACK-PAINTED	4
16	1012375*	PIN-COTTER: .19 X 1.50 NP	8
17	52245*	BEARING CONE-INNER	8
18	52242*	SEAL	8
19	52244*	BEARING-CUP OUTER	8
20	52246*	BEARING-CONE OUTER	8
21	52411	WHEEL 6.00-15 6 BOLT	8
22	52410	TIRE 7.60-15 I-3 6 PLY	8
	68974	TUBE-REPAIR 7.60-15 (NOT SHOWN)	AR
23	52241*	CAP-HUB	8
24	1011612	BOLT-HEX: .50 X 3.50 GR5 ZP	12
25	1027461	NUT-TOPLOCK: .50 NC GR5 ZP	15
26	58283	WLDMT-PIVOT MOUNT	4
27	59204	BUSHING - BORED	8
28	58274	SHAFT	4
29	1011748	ZERK - GREASE	8
30	58410	WLDMT-CYLINDER BRACKET	1
31	62319	CYLINDER HYDRAULIC 2 X 4	1
	69645	SEAL KIT FOR 62319	
32	58203	WLDMT-TIE ROD END LH	1
33	1014124	BOLT-HEX: .31 X 1.50 NC GR5 ZP	2
34	1030729	NUT-HEX: 1.25 NC GR2 LH ZP	3
35	58186	WLDMT-TIE ROD END RH	1
36	1011621	NUT-HEX: 1.25 NC GR2 ZP	3
37	1030700	NUT-TOPLOCK: .31 NC GR5 ZP	2
38	1016858	BOLT-HEX: .50 X 2.75 NC GR5 ZP	3
39	1011626	BOLT-HEX: 1.00 X 3.50 NC GR5 ZP	4

CONTINUED

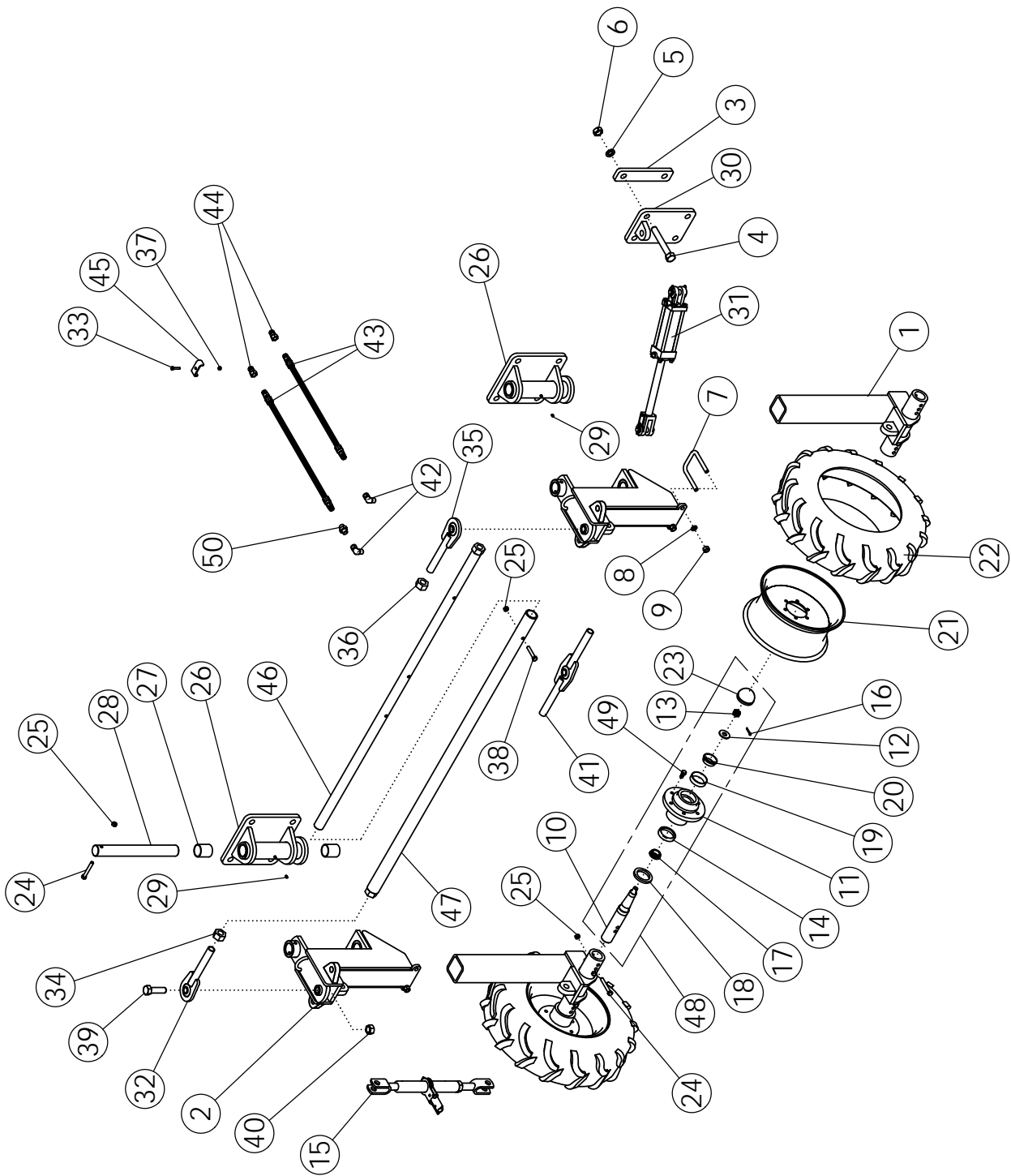

STEERABLE REAR STRUTS - 7.60 X 15 TIRES (CONTINUED)

ITEM	PART NO.	DESCRIPTION	QTY
40	1016969	NUT-TOPLOCK: 1.00 NC GR5 ZP	4
41	58205	WLDMT-TIE ROD END DOUBLE	2
42	1026247	FTG-ELBOW: 6MP-8MJ90	2
43	300032	HOSE: .50 X 336 8MB-8FJX	2
44	36290	PIONEER TIP 8010-15P (#8 ORB)	2
45	50714	CLAMP 1/2" ZP	2
46	58418	WLDMT-TIE ROD MALE 40"	3
47	58417	WLDMT-TIE ROD FEMALE 40"	3
48	52116	ASSY-HUB & SPINDLE	8
49	1013426*	BOLT-LUG: .50 X 1.00 NF GR5 ZP	24
50	300030	FTG-RESTRICTOR 8MJ-8FJ .062	1

* Items are included in Item 48

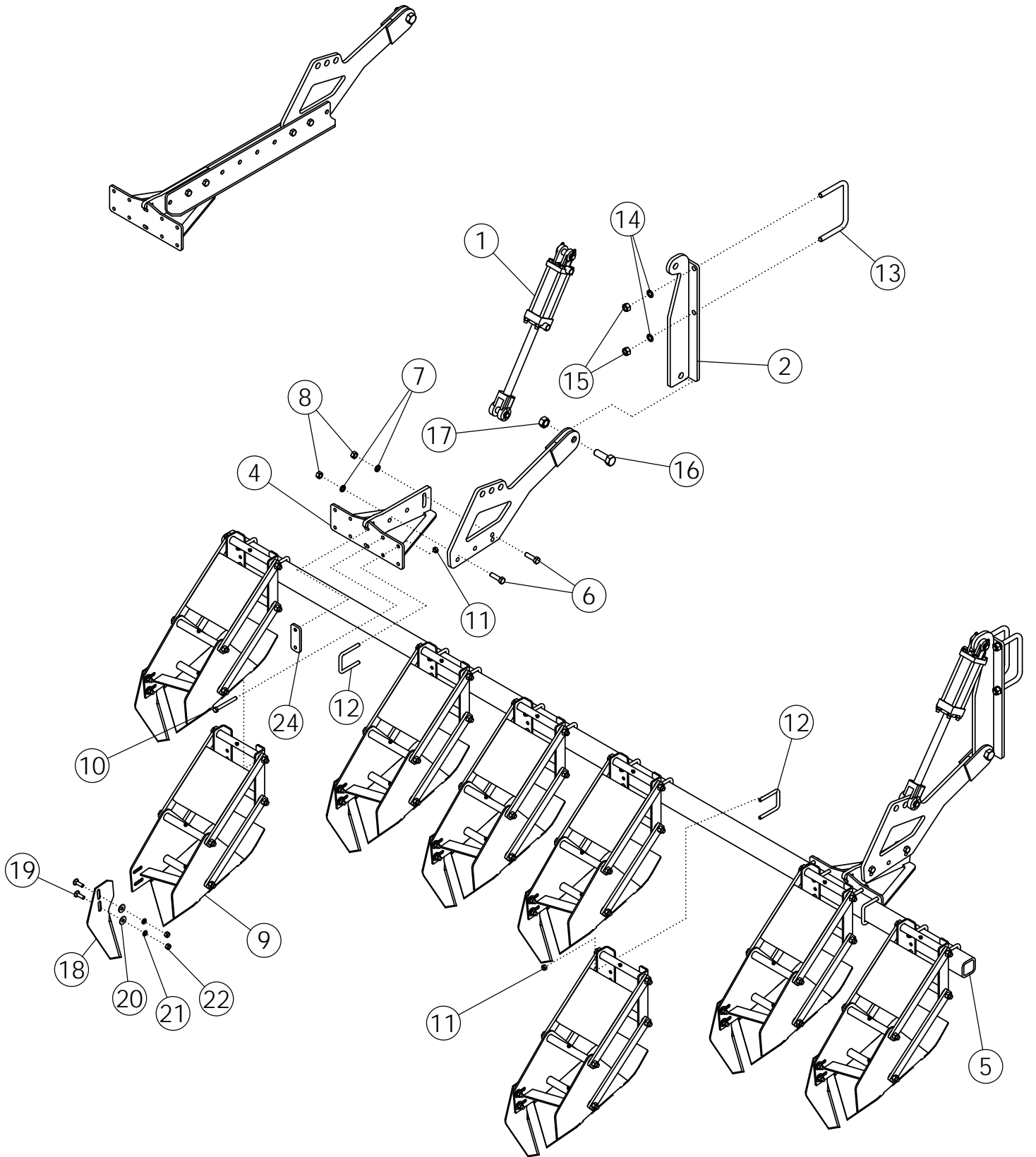

SCALPER BAR ASSEMBLY

ITEM	PART NO.	DESCRIPTION	QTY	
			8R22	6R30
1	58890	CYLINDER HYDRAULIC 3 X 8	2	2
	301314	SEAL KIT FOR 58890 UNIVERSAL		
2	68239	WLDMT - MOUNT	2	2
3	69126	WLDMT-SCALPER ARM MNT	2	2
4	69127	WLDMT-BAR MNT BRACKET	2	2
5	51864	SCALPER BAR	1	1
6	1017526	BOLT-HEX .63 X 2.25 NC GR5 ZP	4	4
7	1011813	WASHER-LOCK: .63 ZP	4	4
8	1011578	NUT-HEX: .63 NC GR2 ZP	4	4
9	63462	ASSY-SCALPER BASKET	6	6
10	1013682	BOLT-HEX: .50 X 4.50 NC GR5 ZP	8	8
11	1027461	NUT-TOPLOCK: .50 NC GR5 ZP	44	36
12	69954	U-BOLT: .50 X 4.50 X 3 X 4.50	18	14
13	56263	U-BOLT: .75 X 5.5 X 8 X 5.5	4	4
14	1012061	WASHER-LOCK: .75 ZP	8	8
15	1011620	NUT-HEX: .75 NC GR2 ZP	8	8
16	1018007	BOLT-HEX: 1.0 X 3.00 NC GR5 ZP	2	2
17	1016969	NUT-TOPLOCK: 1.00 NC GR5 ZP	2	2
18	51782	SCALPER KNIFE-HEAT TREAT	8	6
19	1011660	BOLT-CRG: .50 X 1.50 NC GR5 ZP	16	12
20	1014443	WASHER-FLAT: .50 ZP	16	12
21	1011581	WASHER-LOCK: .50 ZP	16	12
22	1011577	NUT-HEX: .50 NC ZP	16	12
23	305183*	PLATE-SCALPER EXTENSION	4	4
24	51551	BAR-BASKET MOUNTING	2	2

*USED WITH LARGER TIRE OPTION

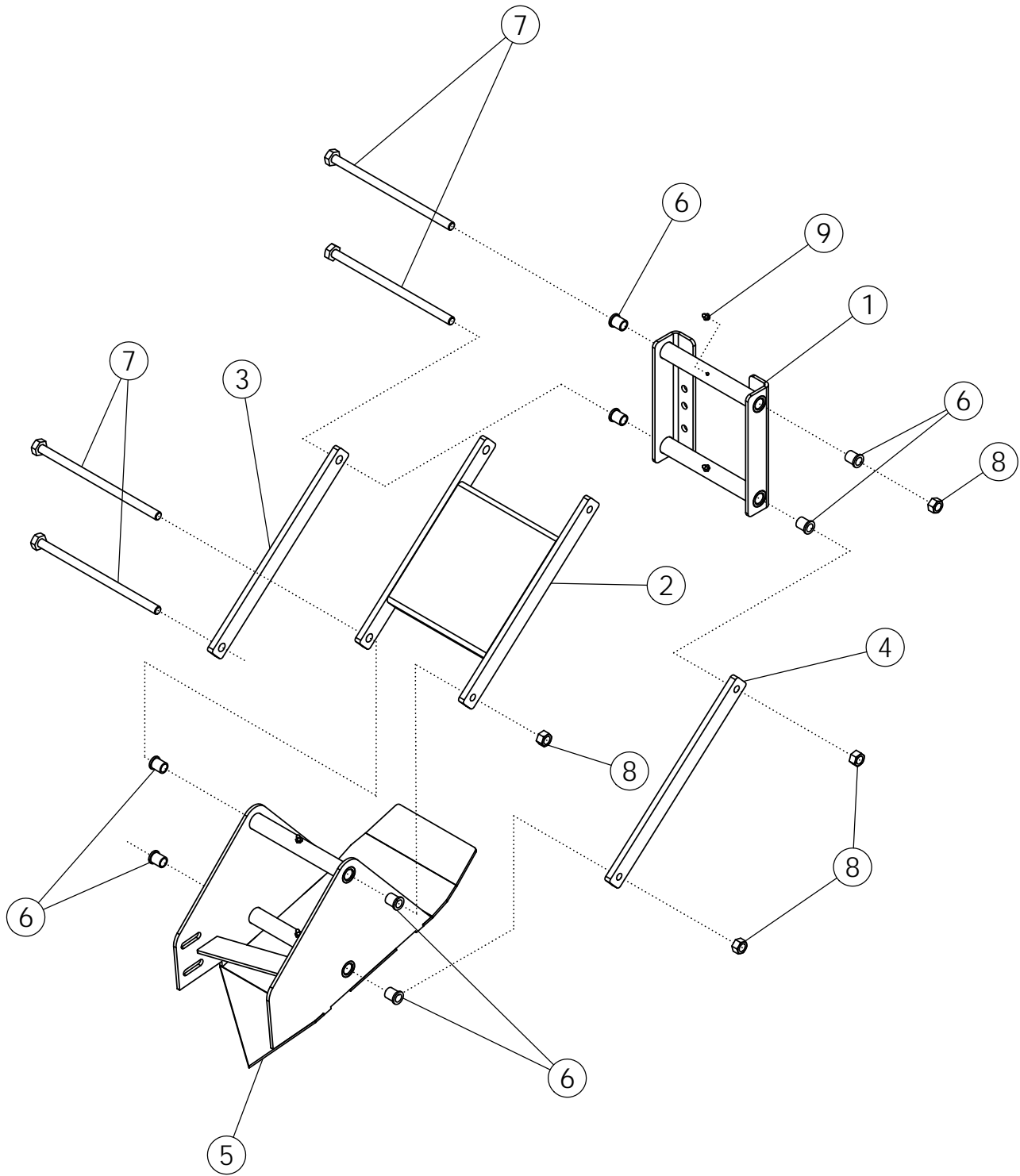

SCALPER BASKET

ITEM	PART NO.	DESCRIPTION	QTY
1	63551	WLDMT-BASKET MOUNT	1
2	63556	WLDMT-UPPER LINK	1
3	63555	BAR-PARALLEL LINK	1
4	63463	BAR-LINK THREADED	1
5	63550	WLDMT-BASKET FRAME	1
6	306080	BUSHING-FLANGE: .628 X 8.16 X 1.4375L	8
7	305854	WLDMT-THREADED ROD SCALPER ZP	4
8	59316	NUT-CENTERLOCK: .625 NC GR5 ZP	4
9	1011748	ZERK-GREASE .25 UNF STRAIGHT	4

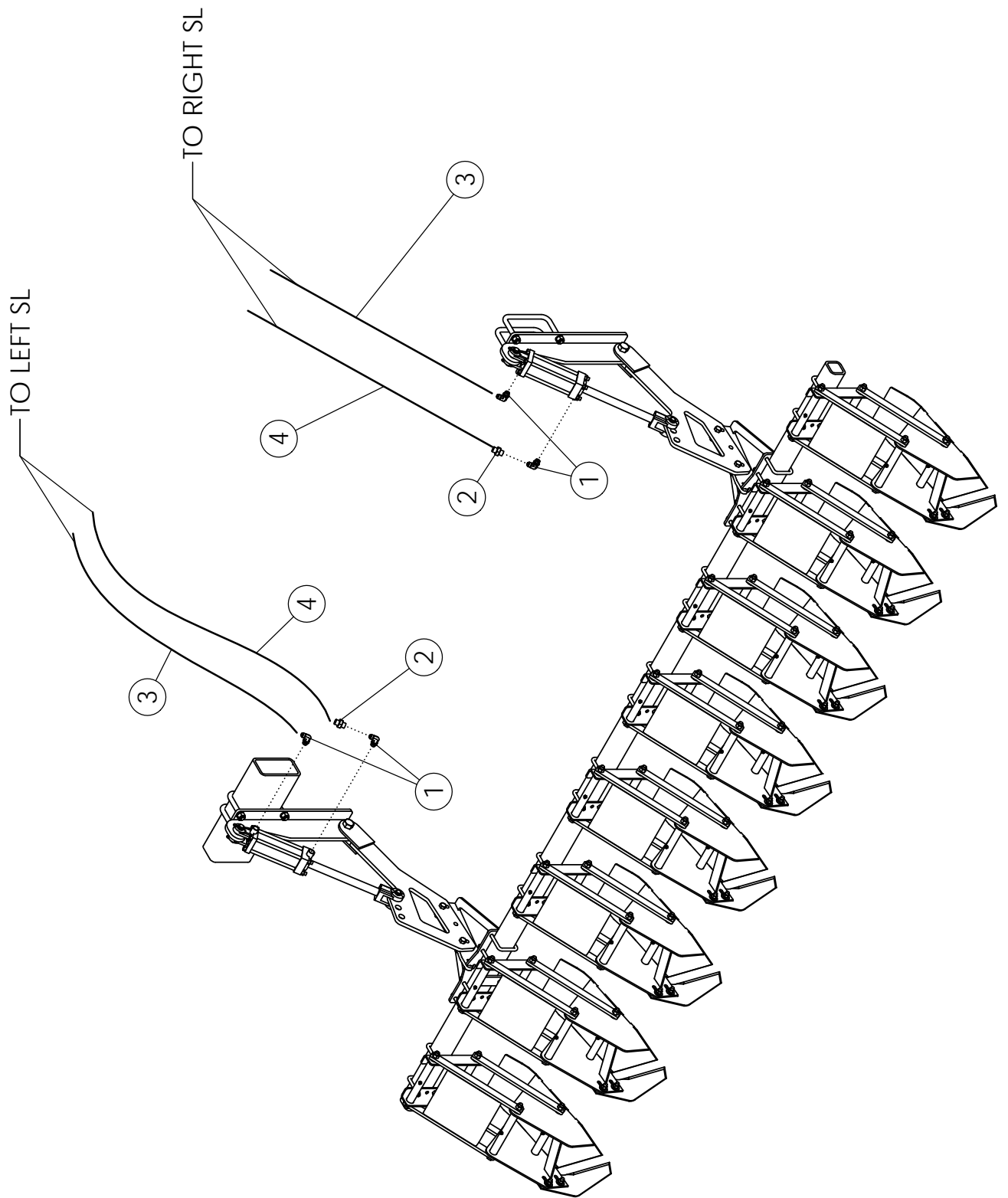

SCALPER BAR MOUNTED ROW FINDER SCALPER HYDRAULICS

ITEM	PART NO.	DESCRIPTION	QTY
1	58560	FTG-ELBOW: 8MB-8MJ-90	4
2	1019844	FTG-RESTRICTOR 8FJ-8MJ	2
3	63005	HOSE: .38 X 048 8FJX-8FJX	2
4	305961	HOSE: .38 X 058 8FJX-8FJX	2

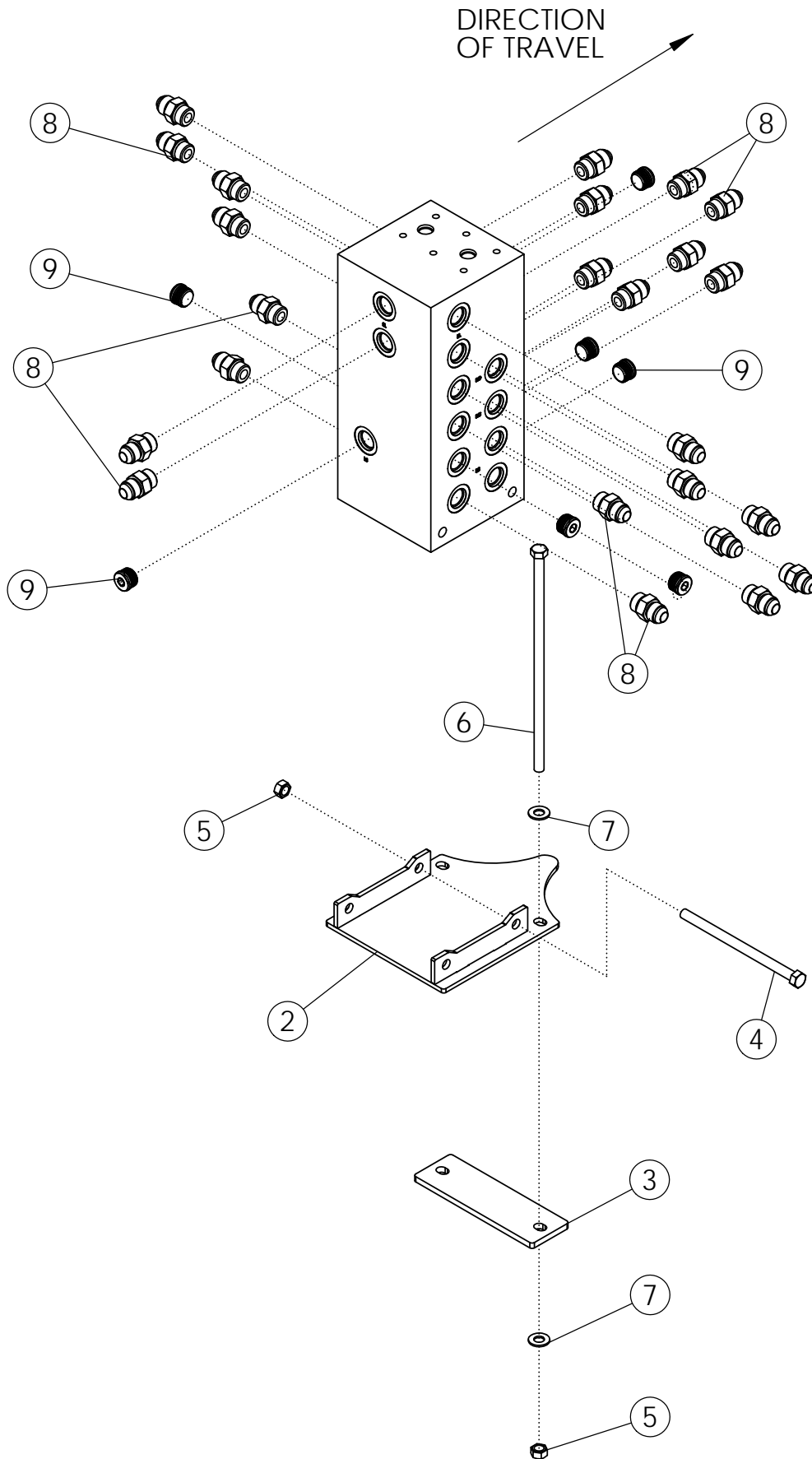

VALVE BLOCK AND MOUNT

ITEM	PART NO.	DESCRIPTION	QTY
1	305960	HYDRAULIC BLOCK DLS	1
2	305659	WLDMT-VALVE BLOCK MOUNT	1
3	305662	PLATE-VALVE BLOCK BOLTING	1
4	34925	BOLT-HEX: .38 X 6.00 NC GR5 ZP	2
5	1016999	NUT-TOPLOCK: .38 NC GR5 ZP	4
6	305663	BOLT-HEX: .38 X 10.00 NC GR5 ZP	2
7	1014608	WASHER-FLT: SAE .38 ZP	4
8	58560	FTG-ELBOW: 8MB-8MJ-90	1
9	56226	FTG-ADAPTER: 8MB-8MJ	24
10	305666	FTG-PLUG: 8MB ALLEN DRIVE	AR

**** BLOCK SHOWN WITH ALL OPTIONS,
IF NOT EQUIPPED BLOCK PORTS ARE
PLUGGED WITH ITEM 10.**

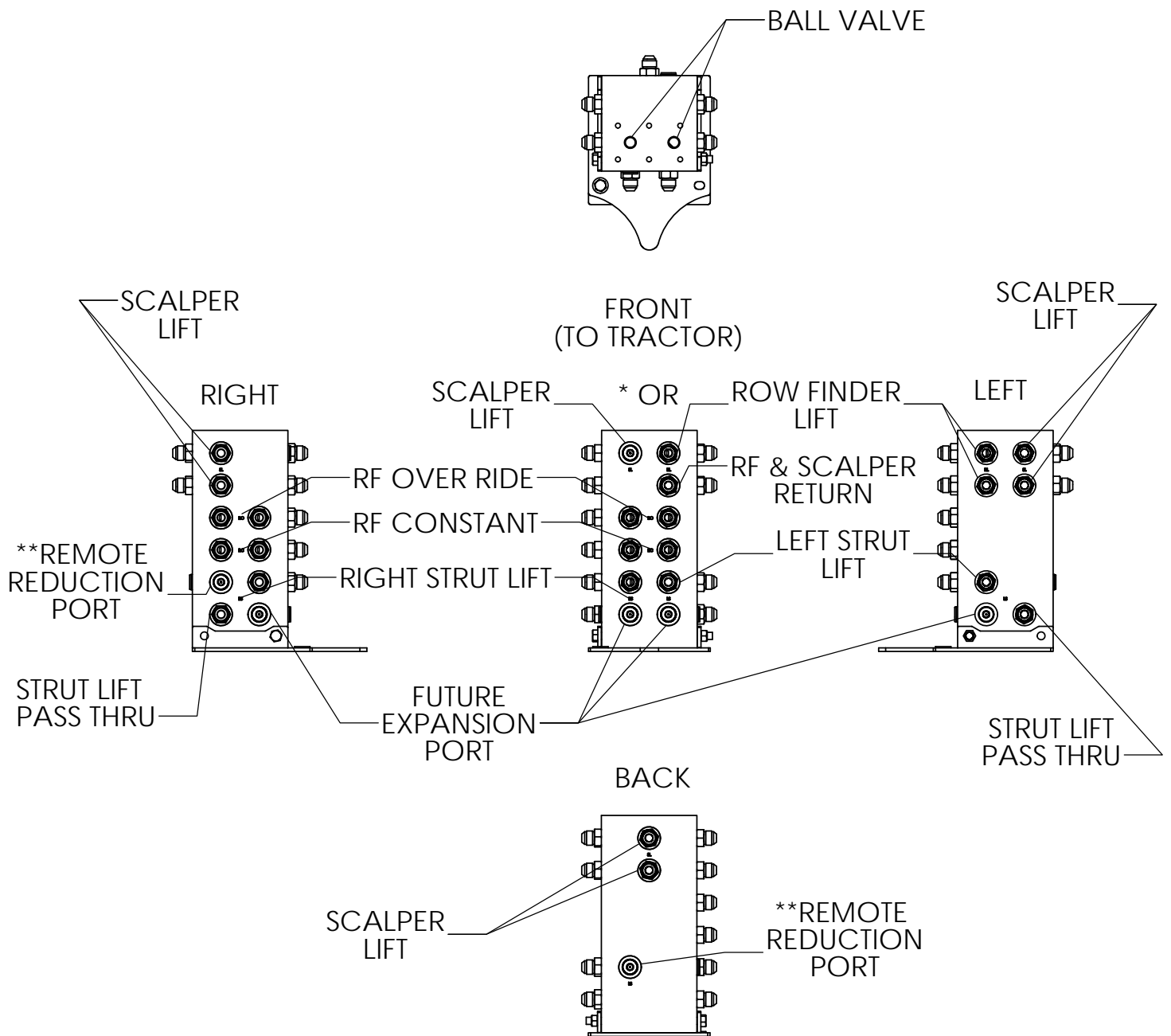

- * EITHER THE SCALPER LIFT OR ROW FINDER LIFT PORT IS USED AND THE OTHER IS PLUGGED.
- IF A FRAME MOUNTED ROW FINDER IS USED, WITH OR WITHOUT SCALPER, THE ROW FINDER LIFT PORT IS USED IN CONJUNCTION WITH A BALL VALVE. ENABELING USE OF BOTH THE SCALPER (IF EQUIPPED) AND ROW FINDER OR ROW FINDER.
- IF A SCALPER WITHOUT FRAME MOUNTED ROW FINDER IS EQUIPPED THE SCALPER LIFT PORT IS USED AND NO BALL VALVE IS INSTALLED.

** REMOTE REDUCTION PORT ALLOWS THE ROW FINDER CONSTANT FUNCTION TO BE TIED INTO THE STRUT LIFT FUNCTION TO ELIMINATE THE NEED FOR ONE ADDITIONAL HYDRAULIC REMOTE ON THE TRACTOR. IN THIS CONFIGURATION RETRACTING OR LOWERING THE STRUTS ALSO POWERS THE ROWFINDER CONSTANT FUNCTION. WHEN EXTENDING THE STRUTS A CHECK VALVE INSTALLED ON THE ROW FINDER PROHIBITS BACKWARDS OIL FLOW.

** AN ALTERNATE OPTION TO REDUCE HYDRAULIC REMOTES REQUIRED WOULD BE TO HOOK UP THE ROW FINDER CONSTANT TO THE TRACTOR'S POWER BEYOND USING AN EXTERNAL FLOW CONTROL SET TO APPROXIMATELY 7 GPM.

**THIS PAGE
INTENTIONALLY
LEFT BLANK**

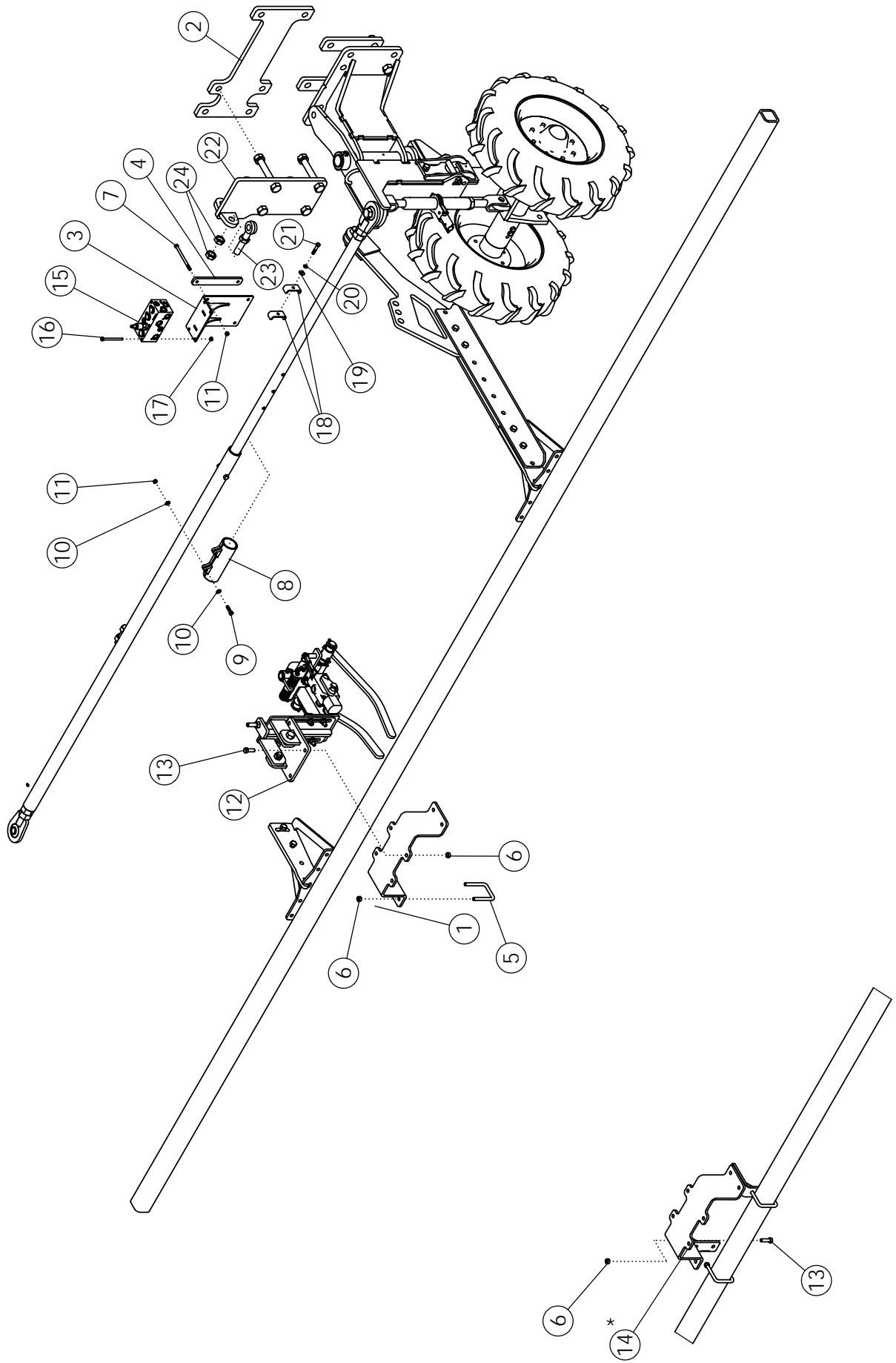

NON-AMITY SCALPER MOUNTING

ROW FINDER - SCALPER MOUNT 6R/8R

ITEM	PART NO.	DESCRIPTION	QTY
1	70021	WLDMT-DEF ROW FINDER MOUNT	1
2	305775	PLATE-DEF CYL MNT STRAP (28.5" STROKE)	1
3	69996	WLDMT-DEF VALVE MNT	1
4	64288	PLATE-BRACKET BACKING	2
5	69954	U-BOLT: .50 X 4.50 X 3 X 4.50	2
6	1027461	NUT-TOPLOCK: .50 NC GR5 ZP	8 OR 12*
7	64289	BOLT-HEX: .38 X 5.50 NC GR5 ZP	4
8	69557	WLDMT-TIE ROD CLAMP	1
9	1011602	BOLT-HEX: .38 X 1.50 NC GR5 ZP	2
10	1014608	WASHER-FLT: SAE .38 ZP	4
11	1016999	NUT-TOPLOCK: .38 NC GR5 ZP	6
12	**NOTE**	HYDRAULIC ROW FINDER	1
13	1011608	BOLT-HEX: .50 X 1.75 NC GR 5 ZP	4 OR 8*
14	69454*	WLDMT-RF MOUNT EXTENSION	2
15	69999	VALVE-DEF RF RETURN	1
16	1030778	BOLT-HEX: .31 X 4.00 NC GR5 ZP	2
17	1030700	NUT-TOPLOCK: .31 NC GR5 ZP	2
18	50714	CLAMP .50" ZP	10
19	1014608	WASHER-FLAT: SAE .38 XP	5
20	1011586	WASHER-LOCK: .38 ZP	5
21	1013239	BOLT-HEX: .38 X 3.00 NC GR5 ZP	4
22	301064	WLDMT-CYLINDER BRACKET ADJ	1
23	62081	BOLT-EYEBOLT 1" X 6" GR 8	1
24	1026880	NUT-HEX JAM: 1.00 NC GR2 ZP	3

* ITEM 14 AND HARDWARE USED ONLY WITH NON AMITY
SCALPER BASKETS

****NOTE****

- ROWFINDER NEEDS TO BE OPEN CENTER (PLUG REMOVED)
- PLACE ROWFINDER ON THE FIRST ROW LEFT OF CENTER
- FOR PARTS, REFERENCE ROWFINDER MANUAL PAGE (M4770)

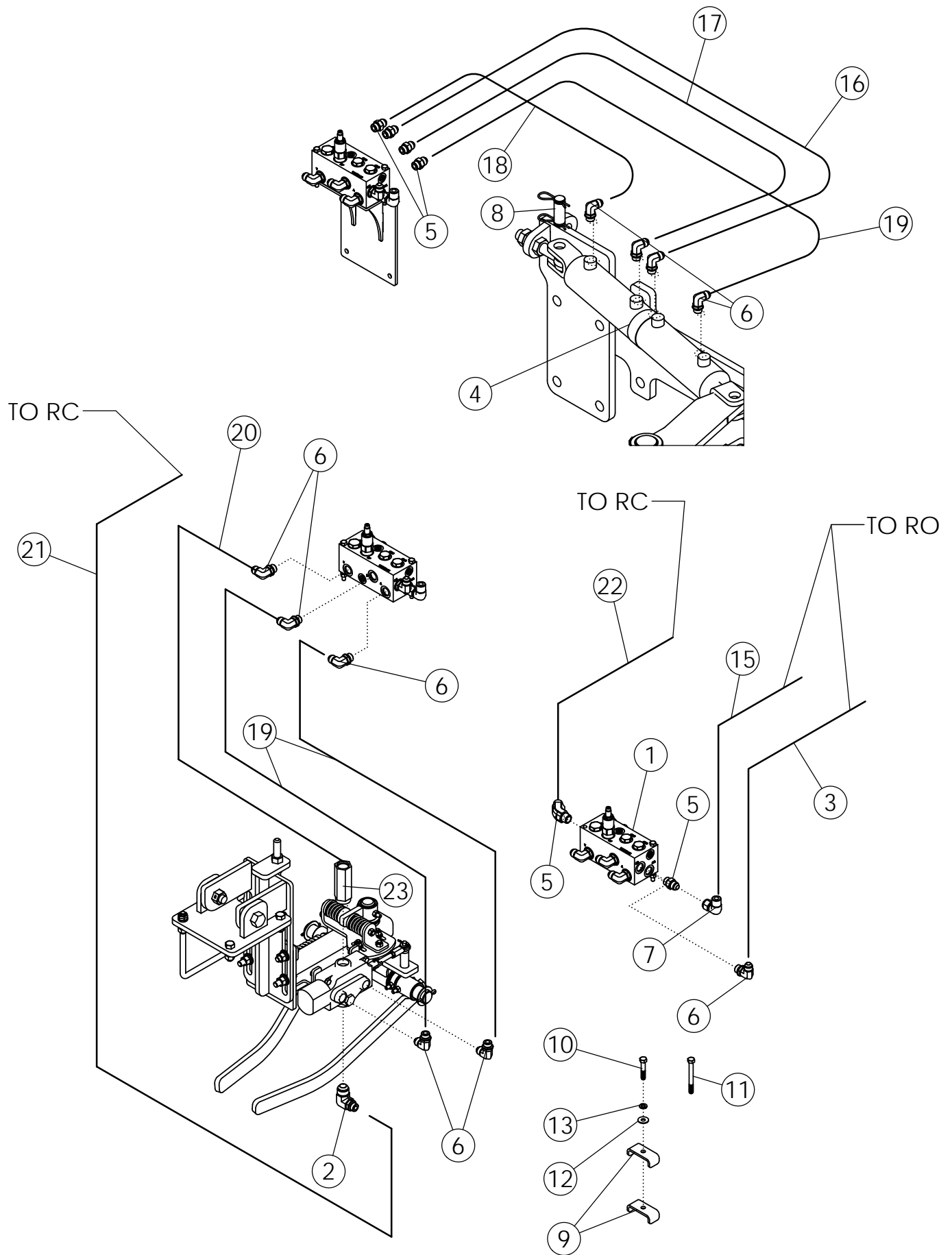

SCALPER MOUNTED ROW FINDER HYDRAULICS

ITEM	PART NO.	DESCRIPTION	QTY
1	69999	VALVE-DEF ROWFINDER RETURN	1
2	65901	FTG-ELBOW: 10MB-8MJ-90	2
3	305677	HOSE: .50 X 027 8FJX-8FJX90	1
4	69200	CYLINDER-HYD 3 X 4 4PORT 23.5 CLOSED	1
5	56226	FTG-ADAPTER: 8MB-8MJ	6
6	58560	FTG-ELBOW: 8MB-8MJ 90	10
7	1015801	FTG-ELBOW: 8MJ-8FJX 90	1
8	69167	PIN-CLYNDER W/CLIPS 1.00 X 2.25	2
9	50714	CLAMP .50" ZP	10
10	1011603	BOLT-HEX: .38 X 1.75 NC GR5 ZP	1
11	1013239	BOLT-HEX: .38 X 3.00 NC GR5 ZP	4
12	1014608	WASHER-FLAT: SAE .38 ZP	5
13	1011586	WASHER-LOCK: .38 ZP	5
14	305677	HOSE: .50 X 027 8FJX-8FJX90L	1
15	69564	HOSE: .50 X 108 8FJX-8FJX90	1
16	69565	HOSE: .50 X 108 8FJX-8FJX90L	1
17	69566	HOSE: .50 X 114 8FJX-8FJX90L	1
18	69567	HOSE: .50 X 102 8FJX-8FJX90	3
19	305681	HOSE: .50 X 090 8FJX-8FJX	
20	69569	HOSE: .50 X 336 8MB-8FJX90	1
21	69570	HOSE: .50 X 252 8FJX-8MB	1
22	305675	HOSE: .50 X 017 8FJX-8FJX	1
23	305665	VALVE-CHECK 10MB-10MJ	1

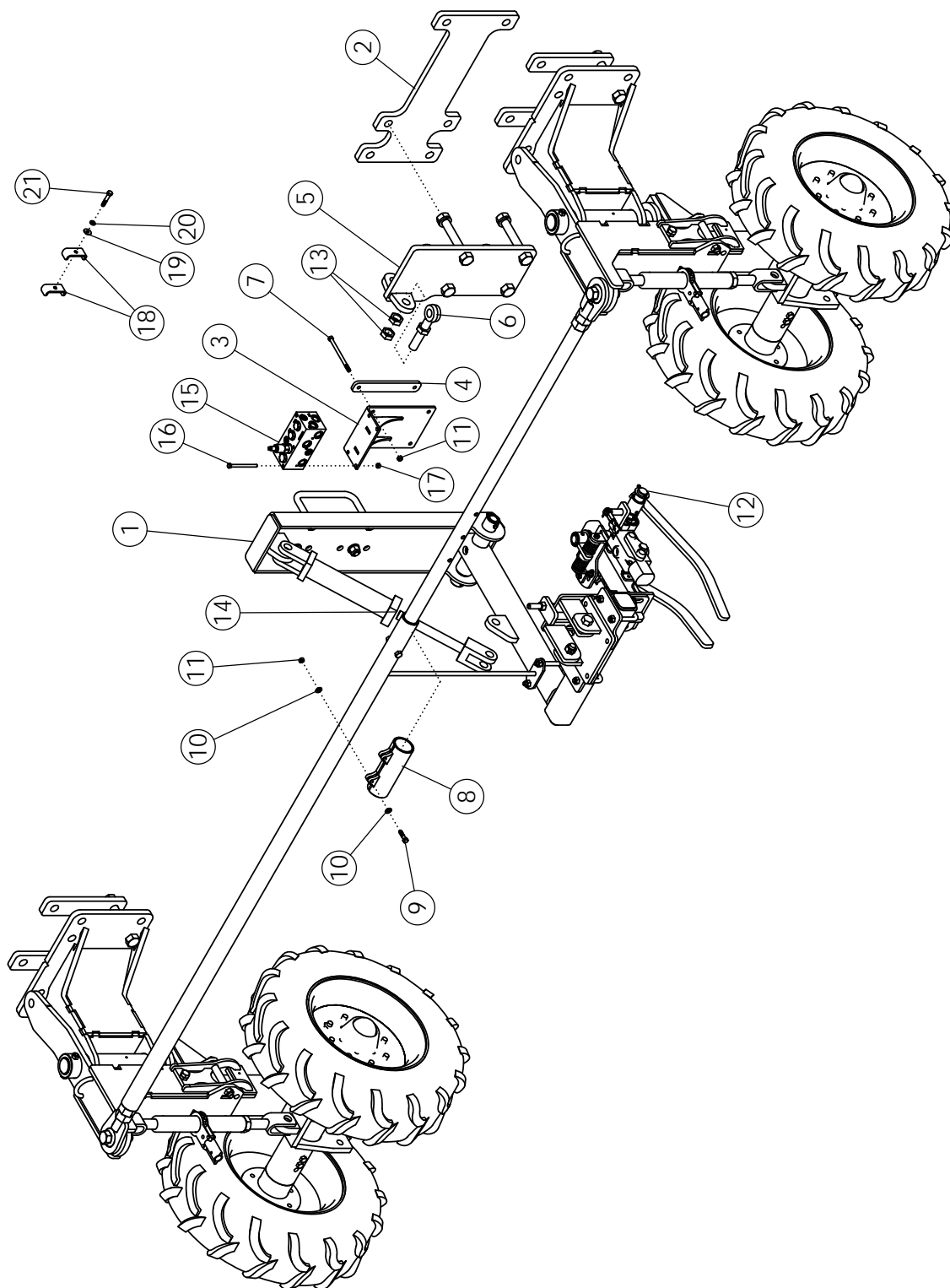

ROW FINDER - FRAME MOUNTED

ITEM	PART NO.	DESCRIPTION	QTY
1	305055	ASSY-DEF ROW FINDER MOUNT	1
2	305775	PLATE-DEF CYL MNT STRAP (28.5" STROKE)	1
3	69996	WLDMT-DEF VALVE MNT	1
4	64288	PLATE-BRACKET BACKING	2
5	301064	WLDMT-CYLINDER BRACKET ADJ	1
6	62081	BOLT-EYEBOLT: 1.00 X 6.00 GR8 ZP	1
7	64289	BOLT-HEX: .38 X 5.50 NC GR5 ZP	4
8	69557	WLDMT-TIE ROD CLAMP	1
9	1011602	BOLT-HEX: .38 X 1.50 NC GR5 ZP	2
10	1014608	WASHER-FLT: SAE .38 ZP	4
11	1016999	NUT-TOPLOCK: .38 NC GR5 ZP	6
12	**NOTE**	HYDRAULIC ROW FINDER	1
13	1026880	NUT-JAM: 1.00 NC GR2 ZP	3
14	33612	CYL-HYD: 20TH08-112ASAE	1
15	69999	VALVE-DEF RF RETURN	1
16	1030778	BOLT-HEX: .31 X 4.00 NC GR5 ZP	2
17	1030700	NUT-TOPLOCK: .31 NC GR5 ZP	2
18	50714	CLAMP .50" ZP	10
19	1014608	WASHER-FLAT: SAE .38 XP	5
20	1011586	WASHER-LOCK: .38 ZP	5
21	1013239	BOLT-HEX: .38 X 3.00 NC GR5 ZP	4

****NOTE****

- ROWFINDER NEEDS TO BE OPEN CENTER (PLUG REMOVED)
- PLACE ROWFINDER ON THE FIRST ROW RIGHT OF CENTER
- FOR PARTS, REFERENCE ROWFINDER MANUAL PAGE (M4770)

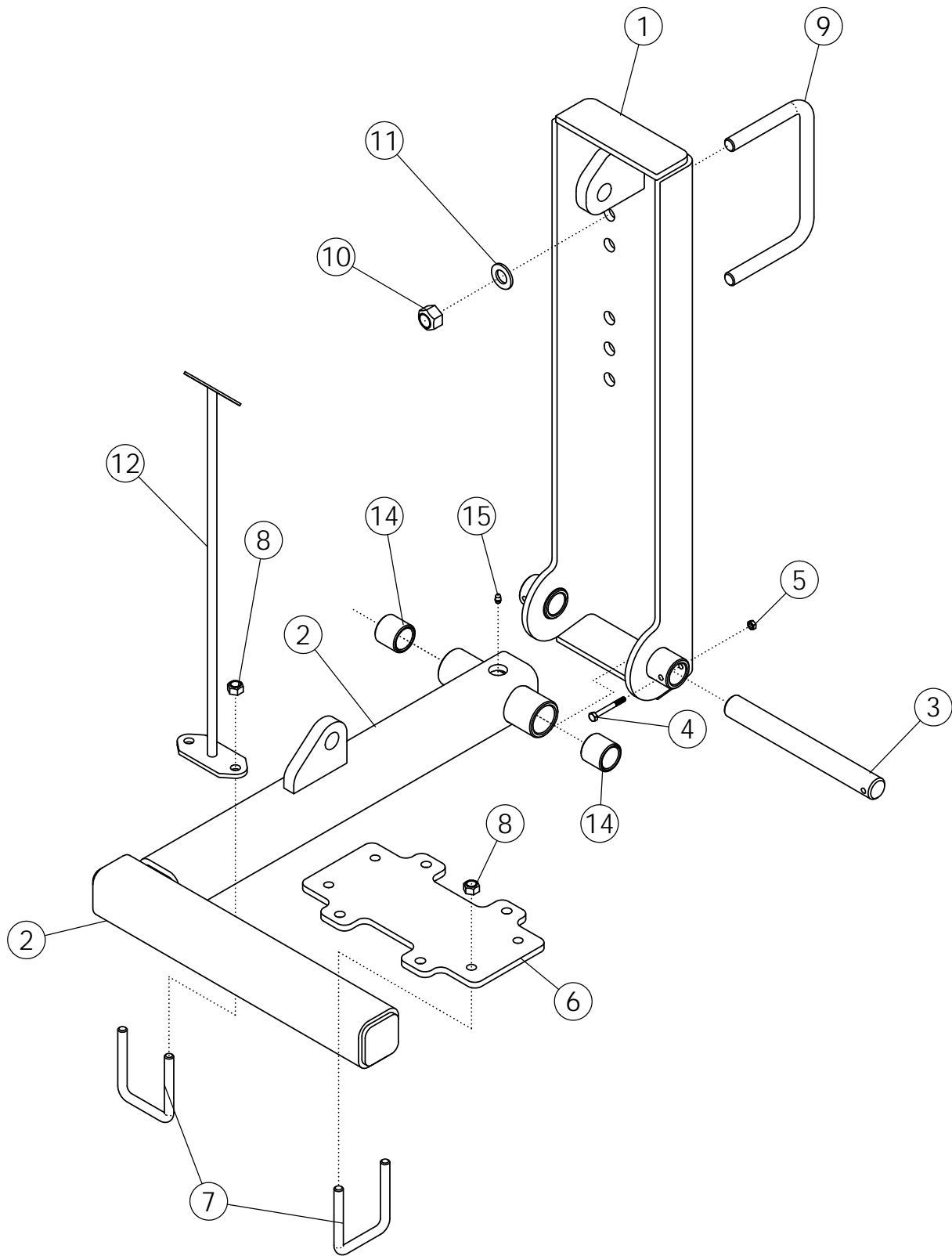

ASSY - DEF ROW FINDER MOUNT

ITEM	PART NO.	DESCRIPTION	QTY
1	305057	WLDMT-ROW FINDER MOUNT UPPER	1
2	305058-1	WLDMT-ROW FINDER LOWER W/ BUSHINGS	1
3	305053	SHAFT-ROW FINDER	1
4	1013942	BOLT-HEX: .25 X 2.25 NC GR5	1
5	1030946	NUT-TOPLOCK: .25 NC GR5 ZP	1
6	305056	PLATE-DEF FR MOUNT (1 ROW)	1
7	69954	U-BOLT: .500 X 4.00 X 3 X 4.00	3
8	1027461	NUT-TOPLOCK: .50 NC GR5 ZP	6
9	56263	U-BOLT: .75 X 5.5 X 8 X 5.5	2
10	1017000	NUT-TOPLOCK: .75 NC GR5 ZP	4
11	1012634	WASHER-FLAT: SAE .75 ZP	4
12	305410	WLDMT-INDICATOR RF FRAME MOUNT	1
13	65332	DECAL-RED/ORANGE FLUORESCENT (NOT SHOWN)	1
14	56939	BUSHING-OILITE: 1.25 X 1.625 X 1.5L	2
15	1011748	ZERK-GREASE: .25 UNF STRAIGHT	1

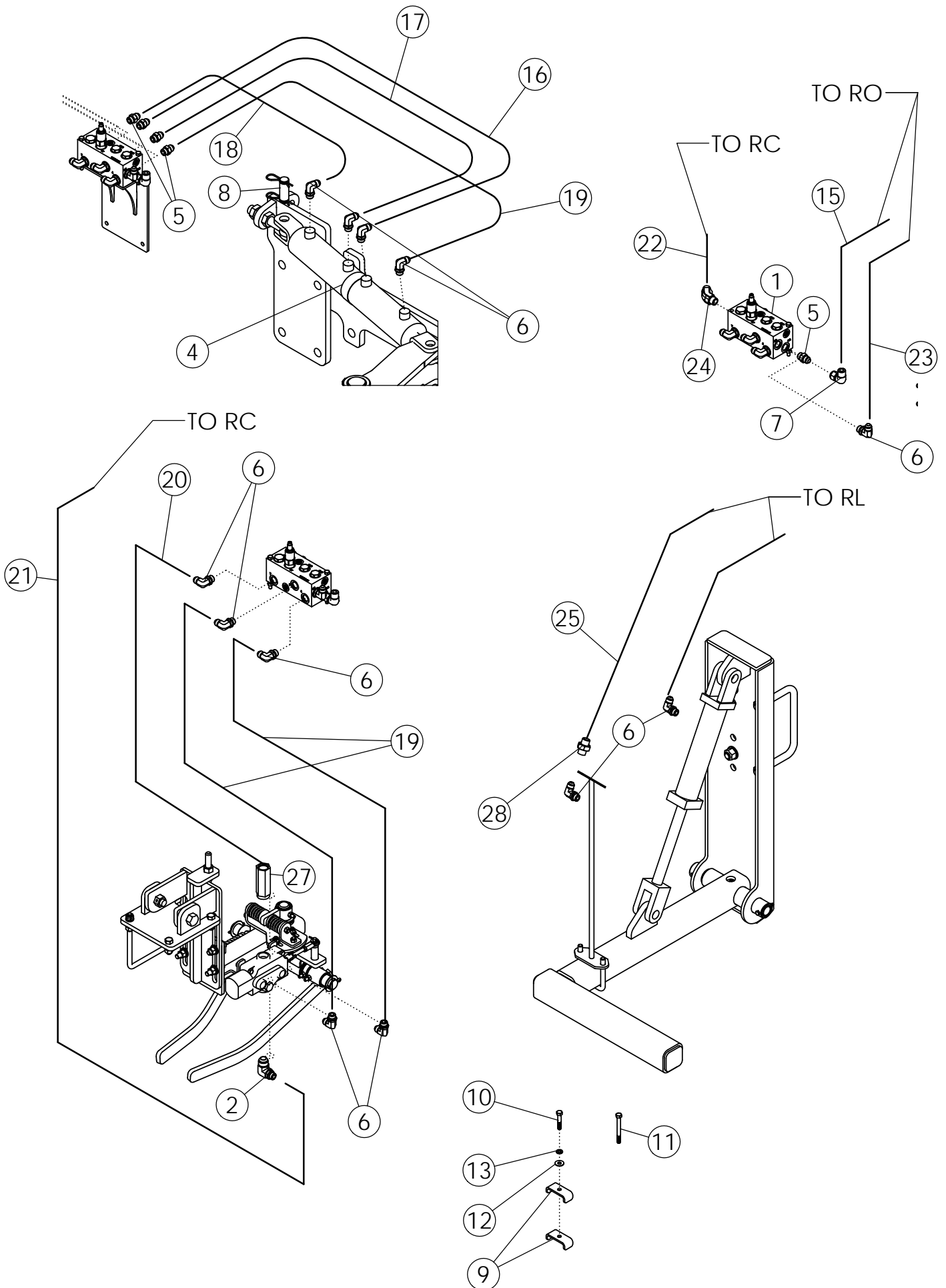

ROW FINDER HYDRAULICS - FRAME MOUNTED

ITEM	PART NO.	DESCRIPTION	QTY
1	69999	VALVE-DEF ROWFINDER RETURN	1
2	65901	FTG-ELBOW: 10MB-8MJ-90	1
3	58195	FTG-ADAPTER: 10MB-8MJ	1
4	69200	CYLINDER-HYD 3 X 4 4PORT 23.5 CLOSED	1
5	56226	FTG-ADAPTER: 8MB-8MJ	6
6	58560	FTG-ELBOW: 8MB-8MJ 90	12
7	1015801	FTG-ELBOW: 8MJ-8FJX 90	1
8	69167	PIN-CYLINDER W/CLIPS 1.00 X 2.25	2
9	50714	CLAMP .50" ZP	10
10	1011603	BOLT-HEX: .38 X 1.75 NC GR5 ZP	1
11	1013239	BOLT-HEX: .38 X 3.00 NC GR5 ZP	4
12	1014608	WASHER-FLAT: SAE .38 ZP	5
13	1011586	WASHER-LOCK: .38 ZP	5
14	305680	HOSE: .50 X 076 X 8FJX-8FJX	2
15	305677	HOSE: .50 X 027 8FJX-8FJX90L	1
16	69565	HOSE: .50 X 108 X 8FJX-8FJX90L	1
17	69566	HOSE: .50 X 114 X 8FJX-8FJX90L	1
18	69567	HOSE: .50 X 102 8FJX-8FJX90	1
19	305681	HOSE: .50 X 090 8FJX-8FJX	1
20	305679	HOSE: .50 X 074 X 10FJX-8FJX90	1
21	305678	HOSE: .50 X 056 X 8FJX-8FJX90	1
22	305675	HOSE: .50 X 017 X 8FJX-8FJX	1
23	305676	HOSE: .50 X 027 X 8FJX-8FJX90	1
24	58515	FTG-ELBOW: 8MB-8MJ-45	1
25	67379	HOSE: .38 X 033 8FJX-8FJX	1
26	305669	HOSE: .38 X 027 8FJX-8FJX90	1
27	305665	VALVE-CHECK 10MB-10MJ	1
28	1019844	FTG-RESTRICTOR 8FJ-8MJ .090	1

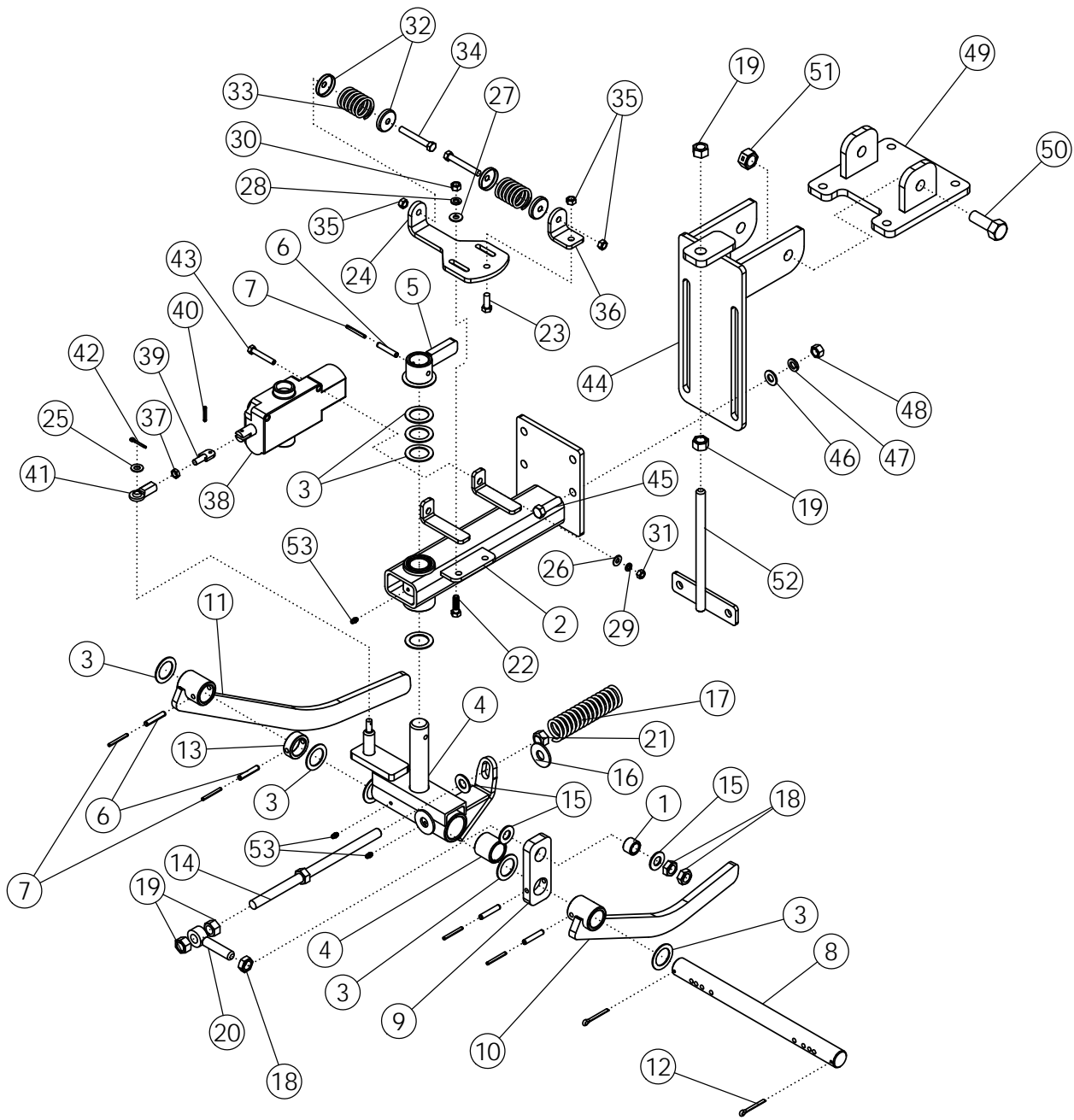

HYDRAULIC ROW FINDER

ITEM	PART NO.	DESCRIPTION	QTY
1	52567	BUSHING-ZP	1
2	62520	ASSY-MAIN FRAME	1
3	55206	BUSHING-MACH: 1.25 NR 14GA	9
4	51139	ASSY - SWIVEL	1
5	51130	WLDMT-FLIPPER	1
6	1030793	PIN-ROLL: .31 X 1.75 ZP	5
7	1030798	PIN-ROLL: .19 X 1.75 ZP	5
8	51690	SHAFT ZP	1
9	52566	TENSIONER ARM	1
10	51131	SENSOR ARM-L.H.	1
11	52564	SENSOR ARM-R.H.	1
12	1030797	PIN-COTTER: .19 X 1.75 NP	2
13	51137	COLLAR	1
14	52565	ADJUSTMENT BOLT	1
15	1013004	WASHER-FLAT: SAE .63 ZP	3
16	1013024	WASHER-FLAT: .63 ZP	2
17	51692	SPRING: .21 X 1.44 OD X 6.00 15 COILS	1
18	1026259	NUT-JAM: .63 NC GR2 ZP	3
19	1011578	NUT-HEX: .63 NC GR2 ZP	4
20	51691	EYEBOLT: .63 X 3.25 ZP	1
21	1016595	NUT-TOPLOCK: .63 NC GR5 ZP	1
22	1011601	BOLT-HEX: .38 X 1.25 NC GR5 ZP	2
23	1011600	BOLT-HEX: .38 X 1.00 NC GR5 ZP	1
24	51129	PLATE	1
25	1014608	WASHER-FLT: SAE .38 ZP	1
26	1020416	WASHER-FLAT: .25 ZP	2
27	1011583	WASHER-FLAT: .31 ZP	2
28	1011586	WASHER-LOCK: .38 ZP	2
29	1029115	WASHER-LOCK: .31 ZP	2
30	1011576	NUT-HEX: .38 NC GR2 ZP	2
31	1011575	NUT-HEX: .31 NC GR2 ZP	2
32	52582	SPRING CAP	4
33	51689	SPRING	2
34	1019828	BOLT-HEX: .38 X 2.75 NC GR5 ZP	2
35	1016999	NUT-TOPLOCK: .38 NC GR5 ZP	3
36	51128	SPRING PLATE	1
37	1030792	NUT-JAM: .38 NF GR2 ZP	1
38	301150	VALVE-ROWFINDER O/C	1
39	62540	PLATE STUD ZP	1
40	64157	PIN-ROLL: .19 X 1.125 ZP	1

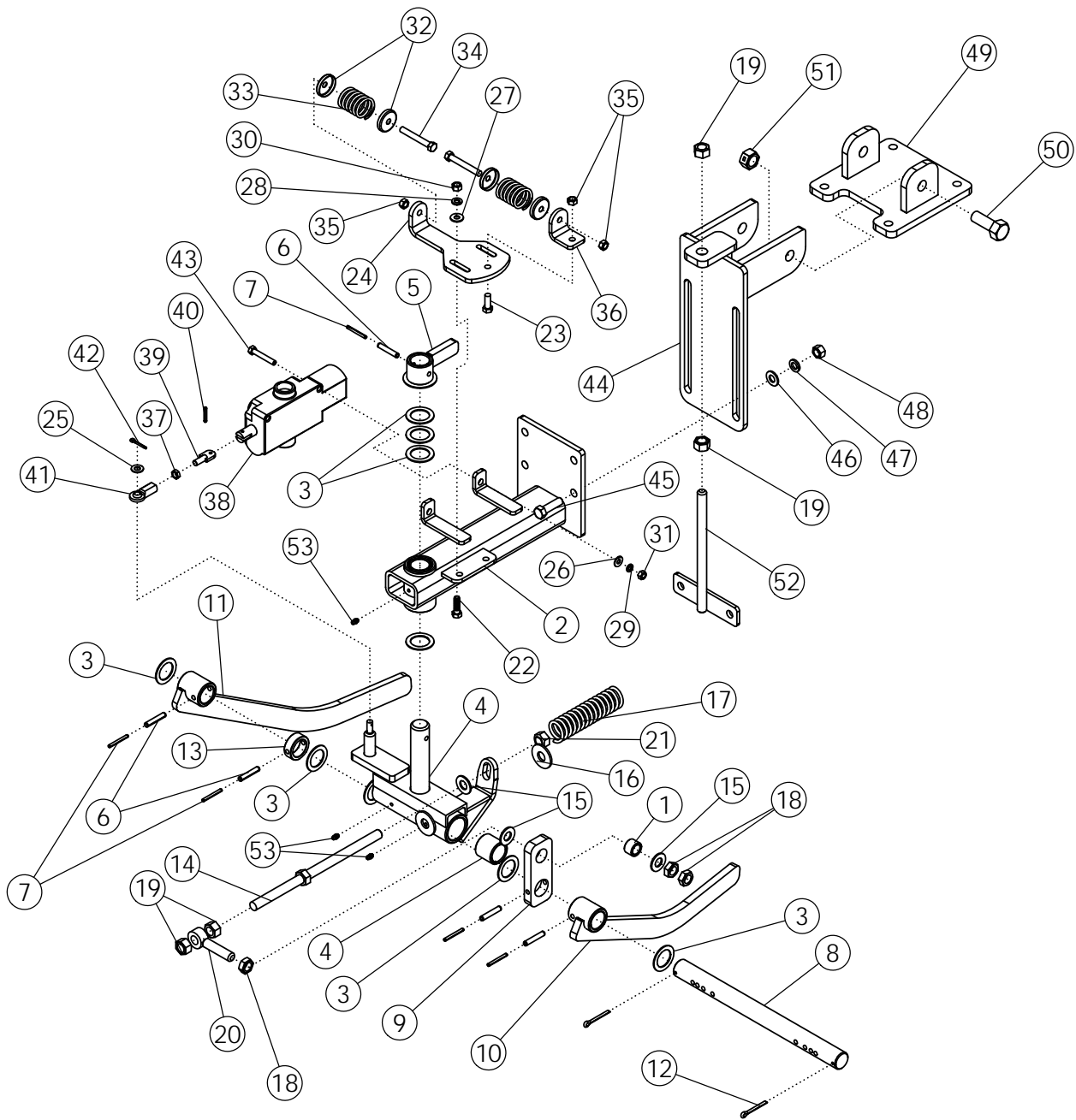

HYDRAULIC ROW FINDER (CONTINUED)

ITEM	PART NO.	DESCRIPTION	QTY
41	51136	UNIBALL COUPLING	1
42	1029137	PIN-COTTER: .13 X 1.00 ZP	1
43	1011285	BOLT-HEX: .31 X 2.00 NC	2
44	52181	MOUNTING BRACKET	1
45	1011608	BOLT-HEX: .50 X 1.75 NC GR5 ZP	4
46	1011584	WASHER-FLAT: SAE .50 ZP	4
47	1011581	WASHER-LOCK: .50 ZP	8
48	1011577	NUT-HEX: .50 NC GR2 ZP	8
49	62871	WLDMT-BRACKET	1
50	1012060	BOLT-HEX: .75 X 2.00 NC GR5 ZP	2
51	1013537	NUT-TOPLOCK: .75 NC GR5 ZP	2
52	62882	TIGHTENER BOLT-ZP	1
53	1011748	ZERK - GREASE	3

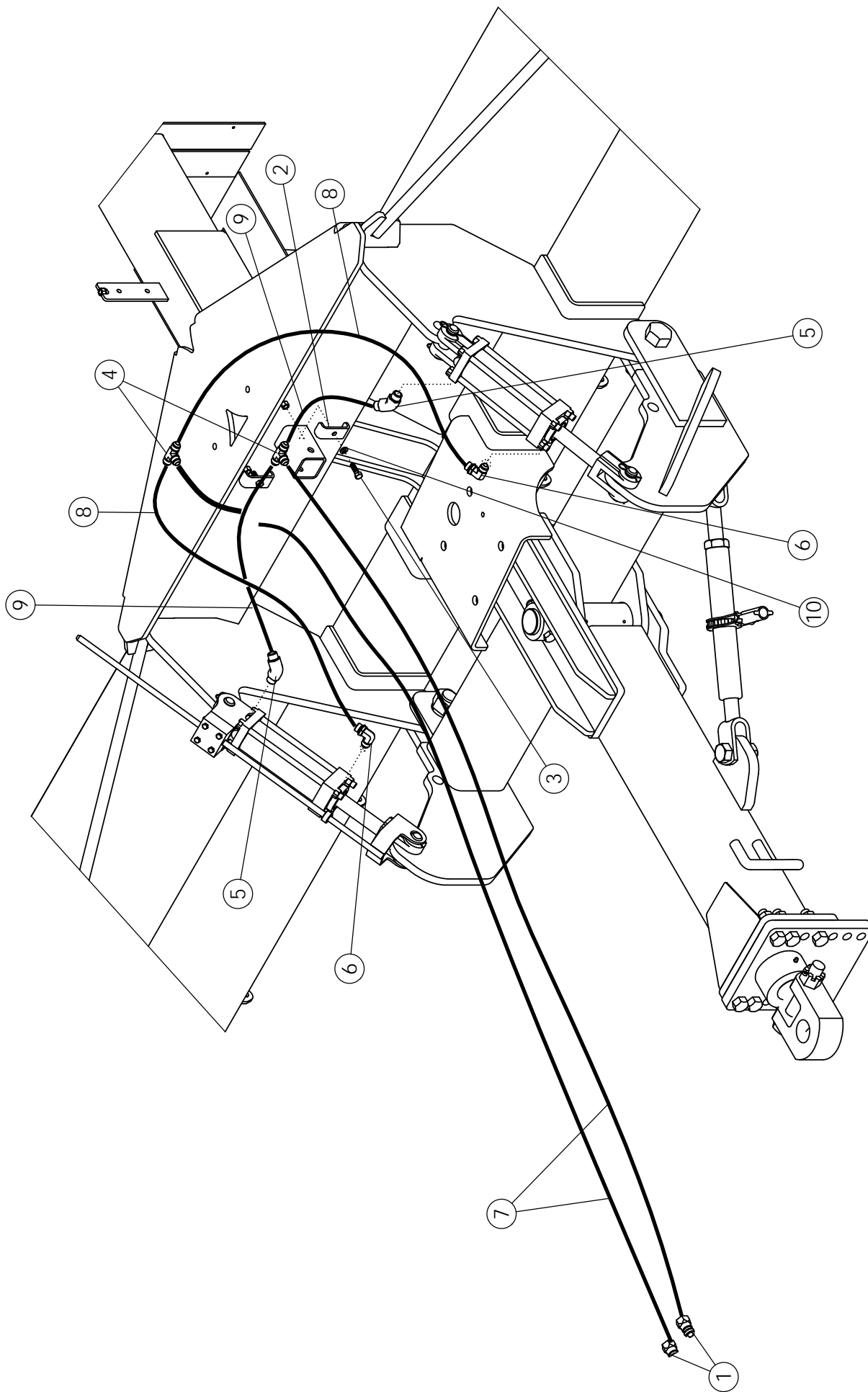

HITCH HYDRAULICS

ITEM	PART NO.	DESCRIPTION	QTY
1	36290	PIONEER TIP 8010-15 (#8 ORB)	2
2	50714	CLAMP .50 ZP	14
3	1011601	BOLT-HEX: .38 X 1.25 NC GR5 ZP	2
4	57667	FTG-TEE: 8MJ-8MJ-8MJ	2
5	58515	FTG-ELBOW: 8MB-8MJ-45	2
6	58560	FTG-ELBOW: 8MB-8MJ-90	2
7	300053	HOSE: .50 X 108 8MB-8FJX	2
8	57000	HOSE .50 X 34 8FJX-8FJX	2
9	44174	HOSE: .50 X 24 8FJX-8FJX	2
10	1011586	WASHER-LOCK: .38 ZP	2

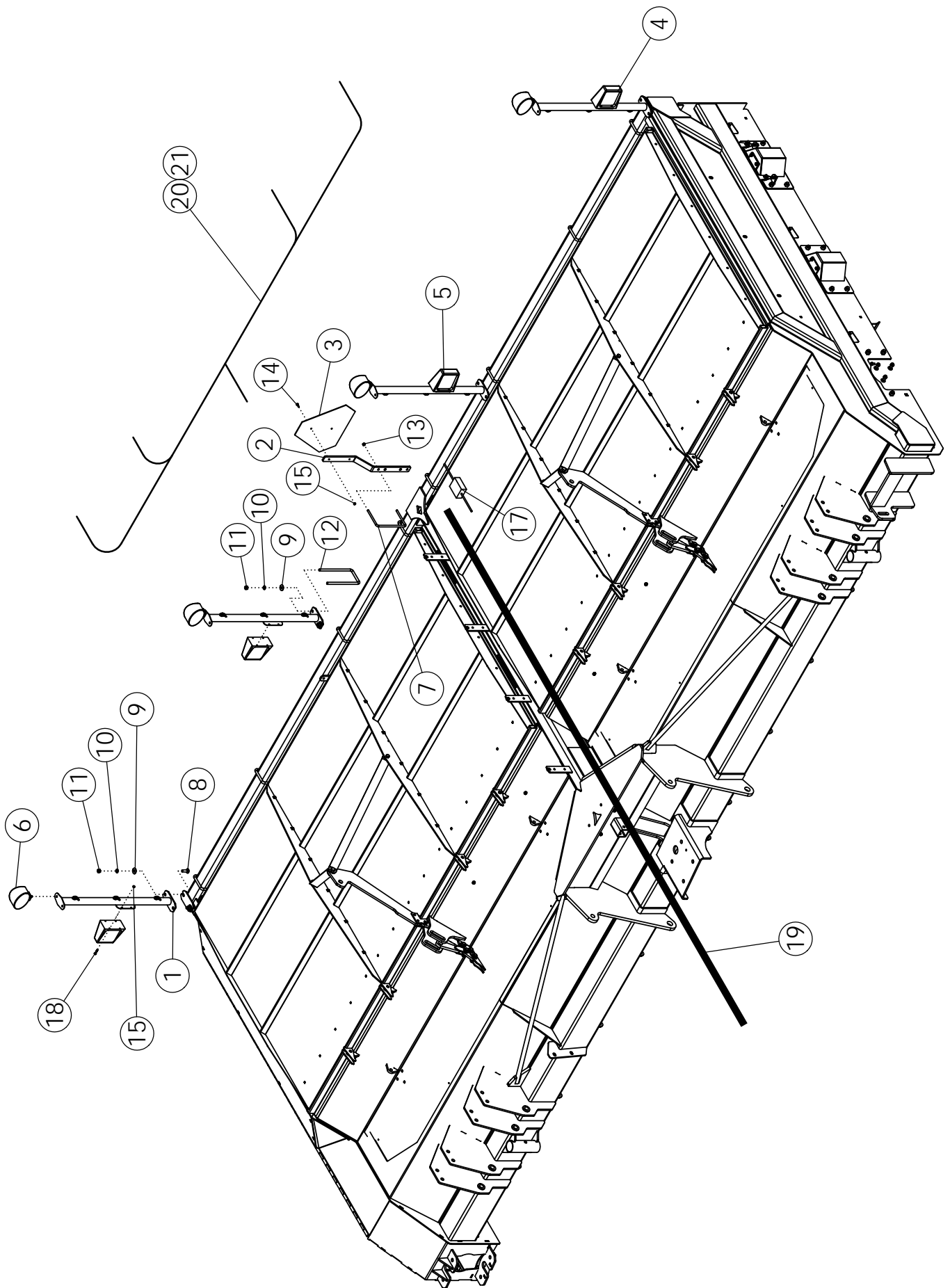

LIGHT KIT

ITEM	PART NO.	DESCRIPTION	QTY
1	305219	WLDMT-LIGHT MOUNT	4
2	64246	MOUNT-SMV SIGN	1
3	65329	SIGN-SMV ASAE	1
4	305217	LIGHT-YELLOW LAMP SAE	2
5	305218	LIGHT-RED LAMP SAE	2
6	301293	LIGHT-GROTE 1200 OVAL FLOOD	4
7	64244	U-BOLT: .375 X 5.125 X 8.063 X 5.125	1
8	1011660	BOLT-CRG: .50 X 1.50 NC GR5 ZP	4
9	1014443	WASHER-FLAT: .50 ZP	8
10	1011581	WASHER-LOCK: .50 ZP	8
11	1011577	NUT-HEX: .50 NC ZP	8
12	63458	U-BOLT: .50 X 9.25 X 4.00 X 9.25 ZP	2
13	1016999	NUT-TOPLOCK: .38 NC GR5 ZP	2
14	1011595	BOLT-HEX: .25 X .75 NC GR5 ZP	2
15	1030946	NUT-TOPLOCK: .25 NC GR5 ZP	18
16	1013122	TIE-NYLON CABLE 50# X 15.50" (NOT SHOWN)	12
17	305214	MODULE-FLASHER HARNESS	1
18	1013940	BOLT-HEX: .25 X 1.25 NC GR5	16
19	305213	HARNESS-DEF LIGHT LEAD	1
20	305214	HARNESS-DEF WORK LIGHT	1
21	305215	HARNESS-DEF LGIHT	1

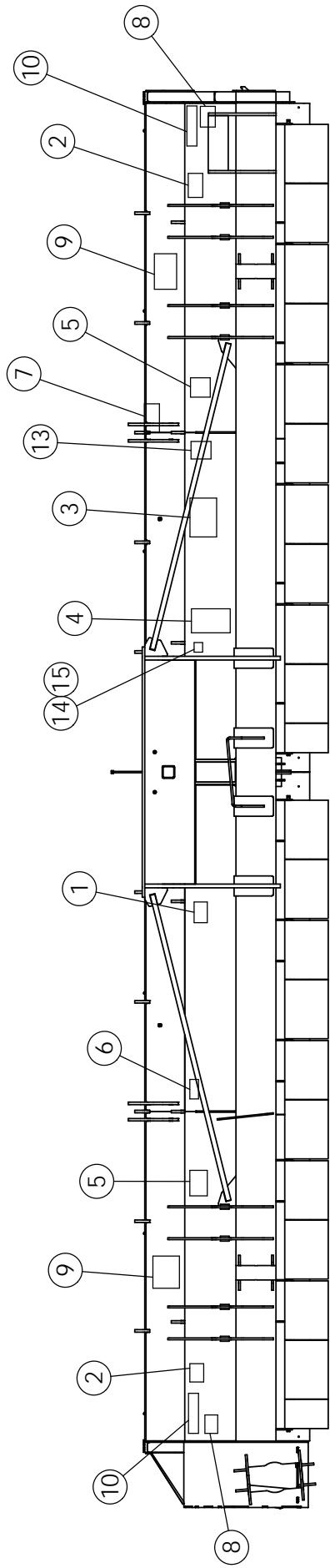

FRONT VIEW

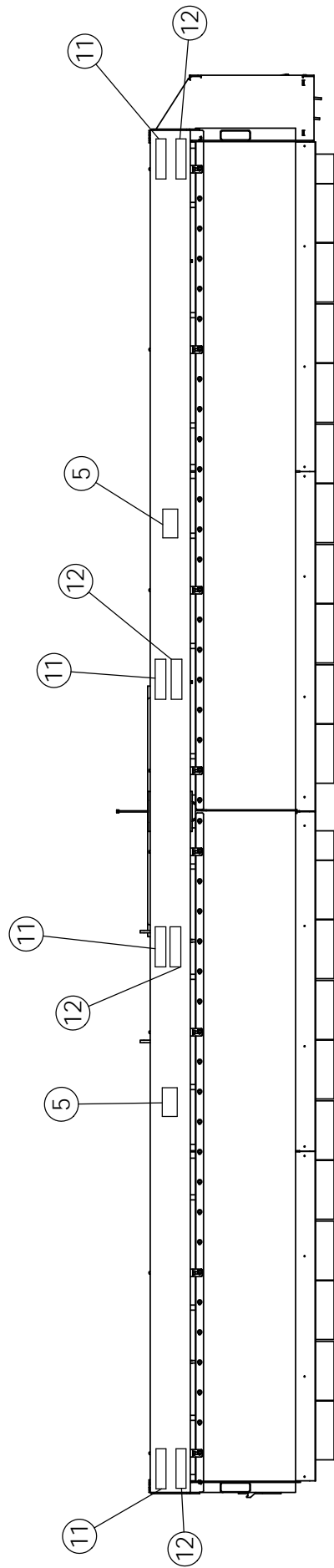

REAR VIEW

DECALS

ITEM	PART NO.	DESCRIPTION	QTY
1	52341	DECAL-WARNING	1
2	52334	DECAL-WARNING	2
3	52329	DECAL-DANGER	1
4	52339	DECAL-WARNING	1
5	52340	DECAL-DANGER	4
6	52338	DECAL DANGER	1
7	52336	DECAL-CAUTION	4
8	64617	DECAL-DANGER	2
9	63465	DECAL-LOGO	2
10	65331	DECAL-RETROFLECTIVE-YELLOW	2
11	65330	DECAL-RETROFLECTIVE-RED	4
12	65332	DECAL-RED ORANGE FLUORESCENT	2
13	62964	DECAL-WARNING	1
14	1028371	TAG: SERIAL#/MODEL#/YEAR	1
15	59882	RIVET-POP: .13 X .31 ZP	2

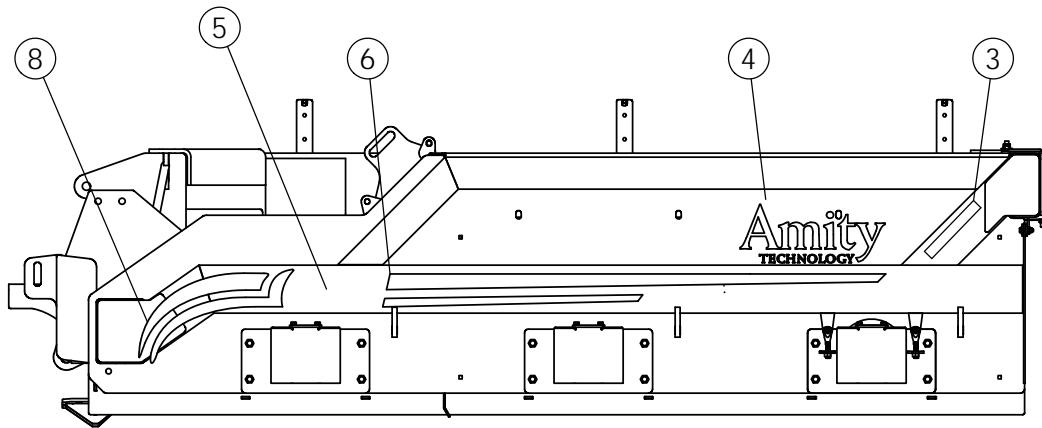
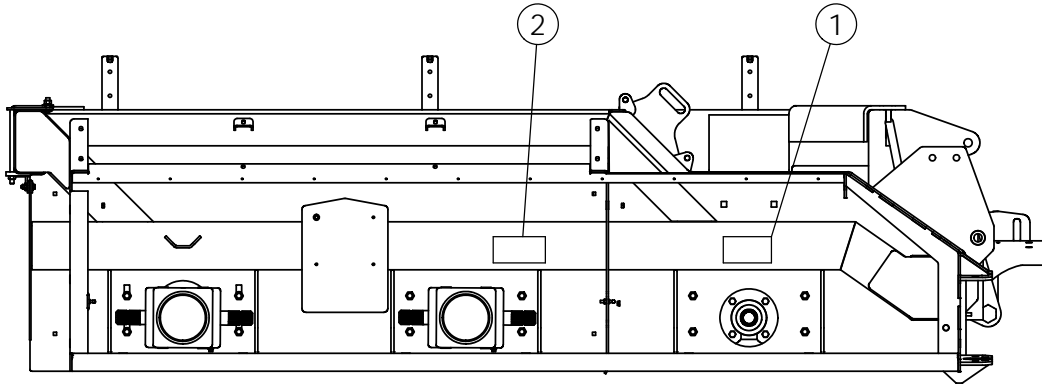
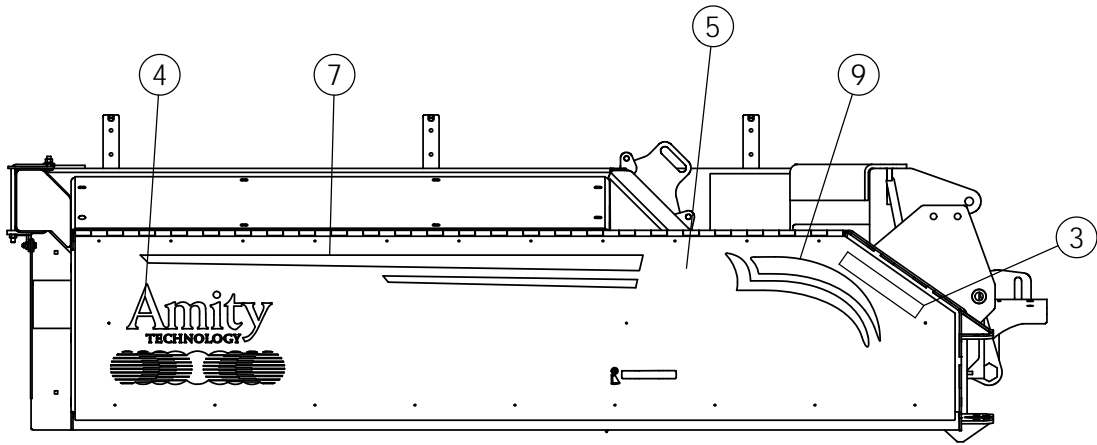

LEFT SIDE

DECALS

ITEM	PART NO.	DESCRIPTION	QTY
1	52341	DECAL-WARNING SHIELDS	1
2	52329	DECAL-DANGER MOVING PART	1
3	65331	DECAL-YELLOW RETROFLECTIVE	2
4	69399	DECAL-AMITY LOGO 12X24	2
5	305692	DECAL-3750 6X12	2
		DECAL-3550 6X12	
6	69406	DECAL-LH STRIPE	1
7	69408	DECAL-RH STRIPE	1
8	69405	DECAL-LH CURVE	1
9	69407	DECAL-RH CURVE	1

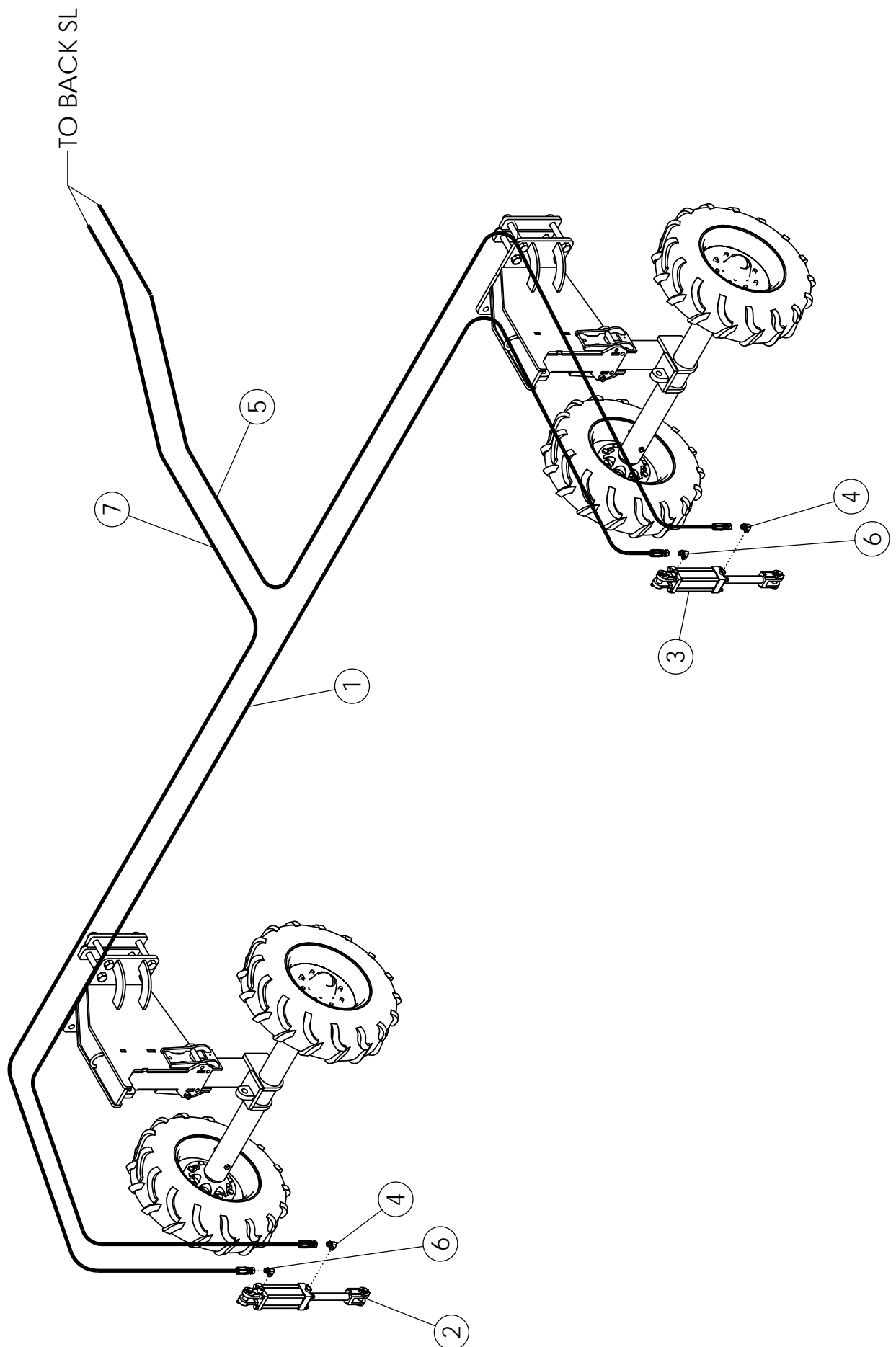

REAR STRUT HYDRAULICS - 11.2 X 24 TIRES (OPTIONAL)

ITEM	PART NO.	DESCRIPTION	QTY
1	72477	HOSE: .38 X 220 8FJX-8FJX	1
2	63500	CYLINDER-HYDRAULIC 3.25 X 8" 3000	1
	66083	SEAL KIT FOR 63500	
3	63499	CYLINDER-HYDRAULIC 3 X 8" 3000	1
	301314	SEAL KIT FOR 63499 UNIVERSAL	
4	58560	FTG-ELBOW: 8MB-8MJ-90	4
5	300047	HOSE: .38 X 348 8MB-8FJX	1
6	36290	PIONEER TIP 8010-15 (#8 ORB)	2
7	300042	HOSE: .38 X 336 8MB-8FJX	1

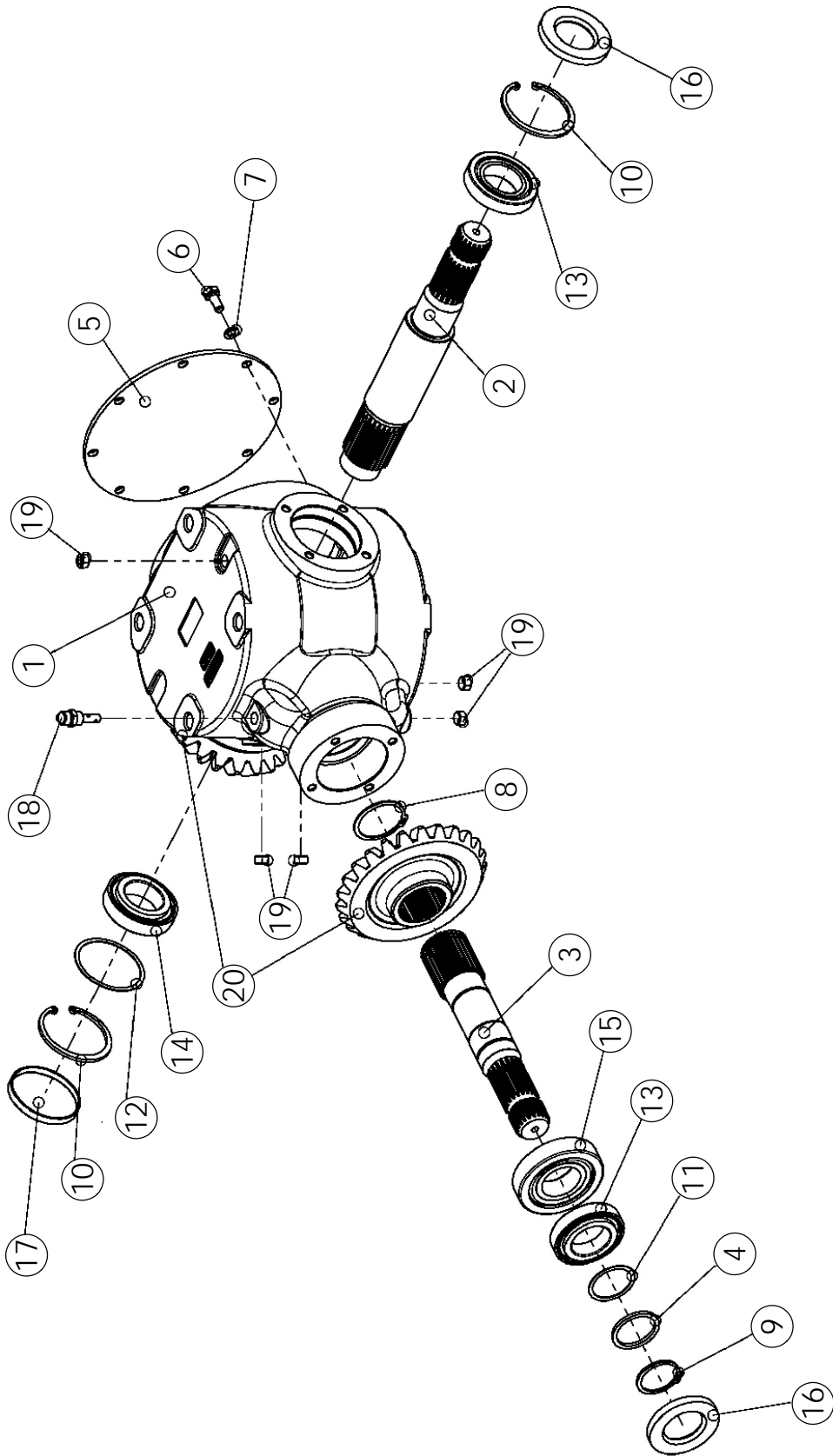

GEARBOX 1.25:1 L #305601

ITEM	PART NO.	DESCRIPTION	QTY
1	305823	HOUSING	1
2	305826	SHAFT	1
3	305825	SHAFT Z-2155	1
4	305829	2155 G-BOX SPACER 50.2X60.3X4	1
5	305830	COVER Ø254 S2150	1
6	68185	SCREW-BOLT HEX M10 X 25 CL8.8	8
7	68186	WASHER	8
8	305832	CIRCLIP EXTERNAL 60X2.00 DIN471	1
9	305834	CIRCLIP EXTERNAL 50X3.00 DIN471/2 THICK	1
10	305835	INTERNAL SNAP RING 90X4	2
11	305836	SHIM KIT Ø50MM SHAFT (59.8X50.2)	1
12	305837	SHIM KIT Ø90MM BORE (89.8X80.2)	1
13	305839	T. ROLLER BEARING 50X90X21.75 30210	2
14	305840	T. ROLLER BEARING 50X90X24.75 32210	1
15	305841	T. ROLLER BEARING 50X110X29.25 30310	1
16	305899	OIL SEAL 50X90X10	2
17	305845	OIL SEAL CAP 90X10	1
18	305846	BREATHER PLUG	1
19	54215	OIL PLUG	5
20	305849	BEVEL GEAR SET R=1.25 S2150	1

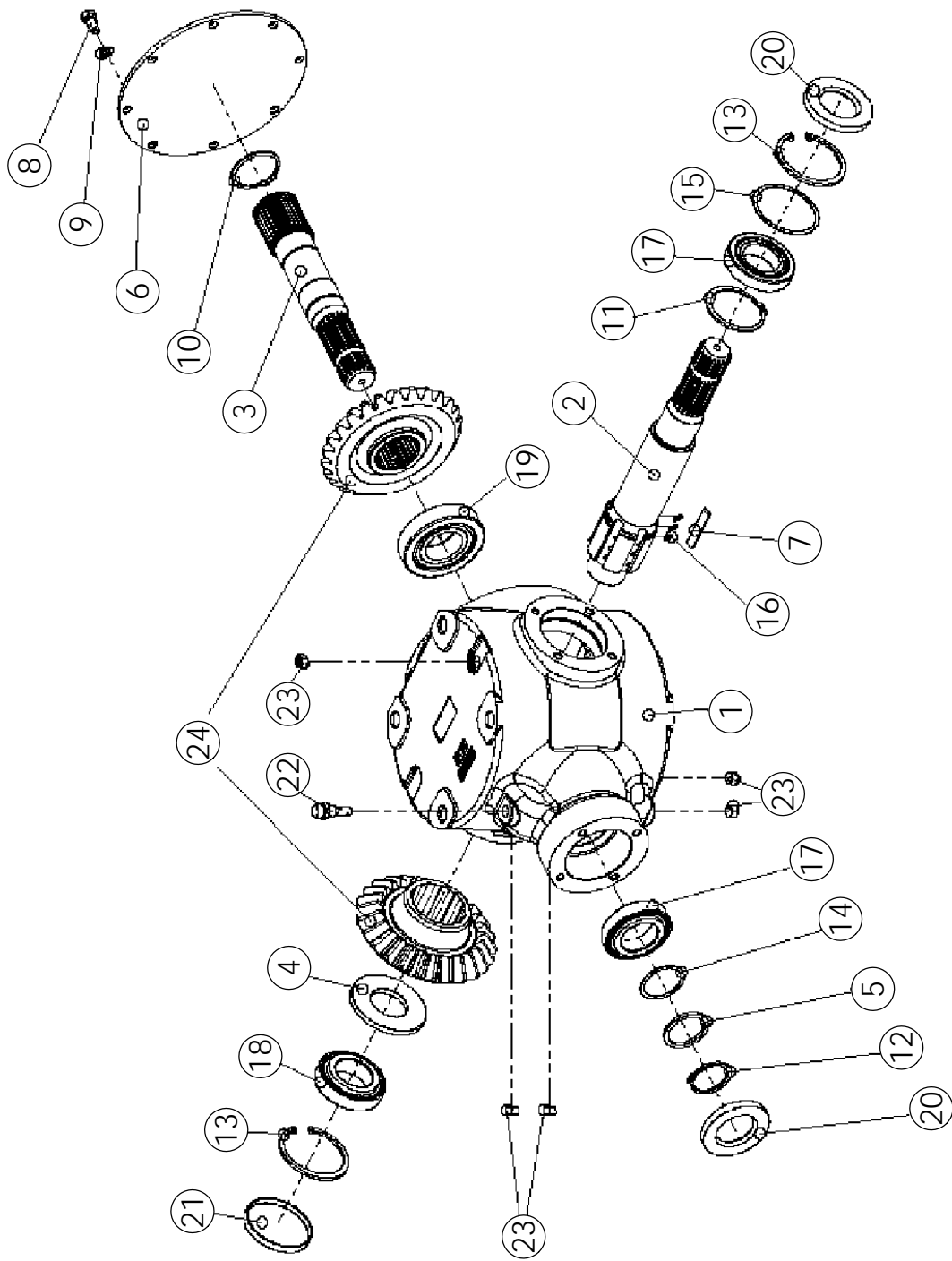

GEARBOX 1:1 W/OVERRUN CLUTCH #305602

ITEM	PART NO.	DESCRIPTION	QTY
1	305823	HOUSING	1
2	305827	SHAFT	1
3	305825	SHAFT Z-2155	1
4	305828	SPACER 8MM S2155 W/RL	1
5	305829	2155 G-BOX SPACER 50.2X60.3X4	1
6	305830	COVER Ø254 S2150	1
7	305831	RATCHET S2155 W/RL L=60	6
8	68185	SCREW-BOLT HEX M10 X 25 CL8.8	8
9	68186	WASHER	8
10	305832	CIRCLIP EXTERNAL 60X2.00 DIN471	1
11	305833	CIRCLIP EXTERNAL 72X2.50 DIN471	1
12	305834	CIRCLIP EXTERNAL 50X3.00 DIN471/2 THICK	1
13	305835	INTERNAL SNAP RING 90X4	2
14	305836	SHIM KIT Ø50MM SHAFT (59.8X50.2)	1
15	305837	SHIM KIT Ø90MM BORE (89.8X80.2)	1
16	59960	SPRING-GEAROX SHAFT	18
17	305839	T. ROLLER BEARING 50X90X21.75 30210	2
18	305840	T. ROLLER BEARING 50X90X24.75 32210	1
19	305841	T. ROLLER BEARING 50X110X29.25 30310	1
20	305899	OIL SEAL 50X90X10	2
21	305845	OIL SEAL CAP 90X10	1
22	305846	BREATHER PLUG	1
23	54215	OIL PLUG	5
24	305848	BEVEL GEAR SET R=1:1 -2155- RL	1

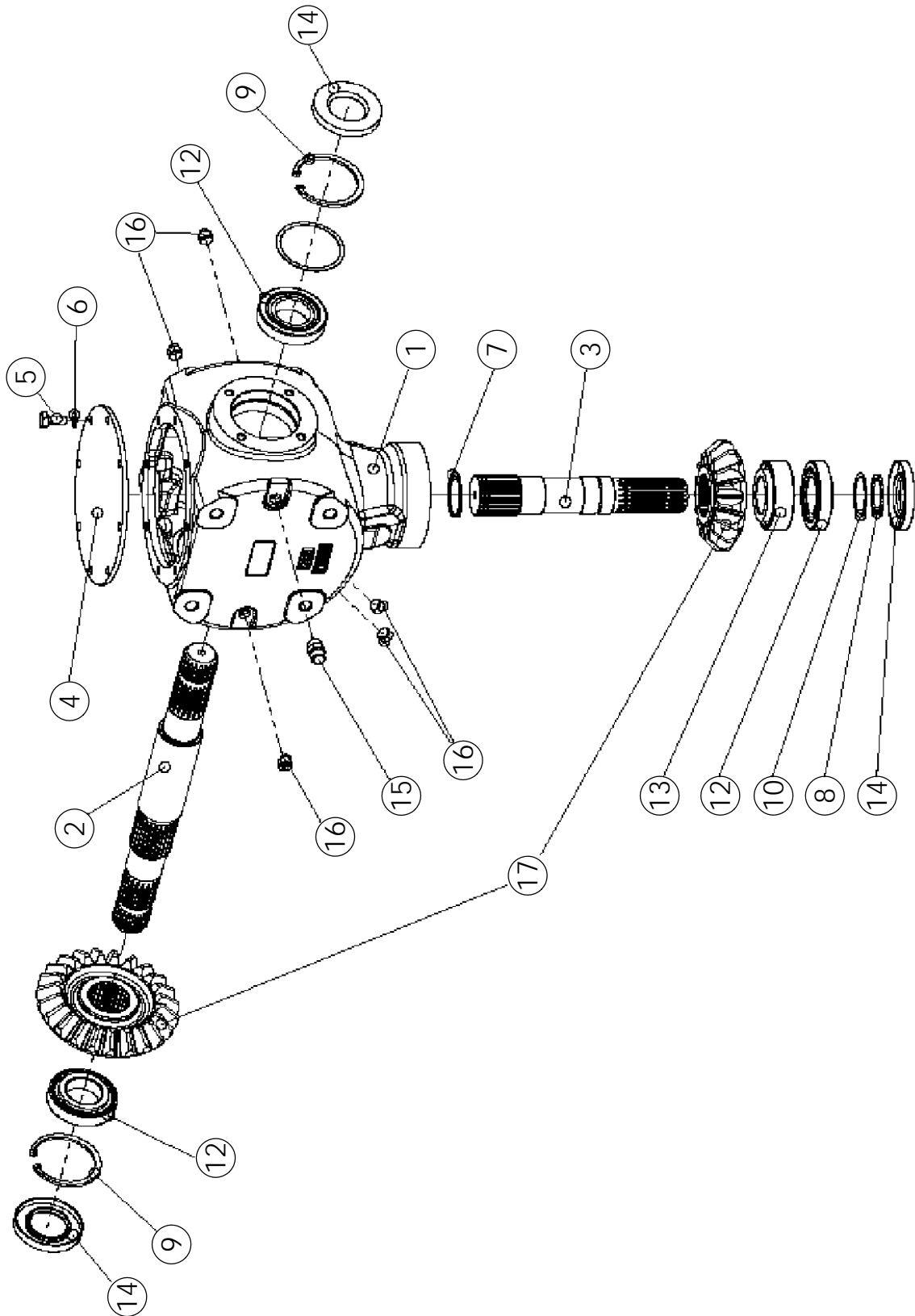

GEARBOX T 1:1.35 #305603

ITEM	PART NO.	DESCRIPTION	QTY
1	68181	HOUSING	1
2	68193	SHAFT-THRU	1
3	38194	SHAFT	1
4	68184	SLEEVE	1
5	68185	SCREW-BOLT HEX M10 X 25 CL8.8	8
6	68186	WASHER	8
7	52521	SNAP RING: EXTERNAL	1
8	54209	SNAP RING	1
9	54210	SNAP RING	2
10	64421	KIT-SPACER RING	1
11	64422	KIT-SPACER RING	1
12	54212	BEARING ROLLER	3
13	68187	BEARING-ROLLER	1
14	54214	SEALING RING	3
15	54204	VENT PLUG	1
16	54215	OIL PLUG	5
17	68188	GEAR SET	1

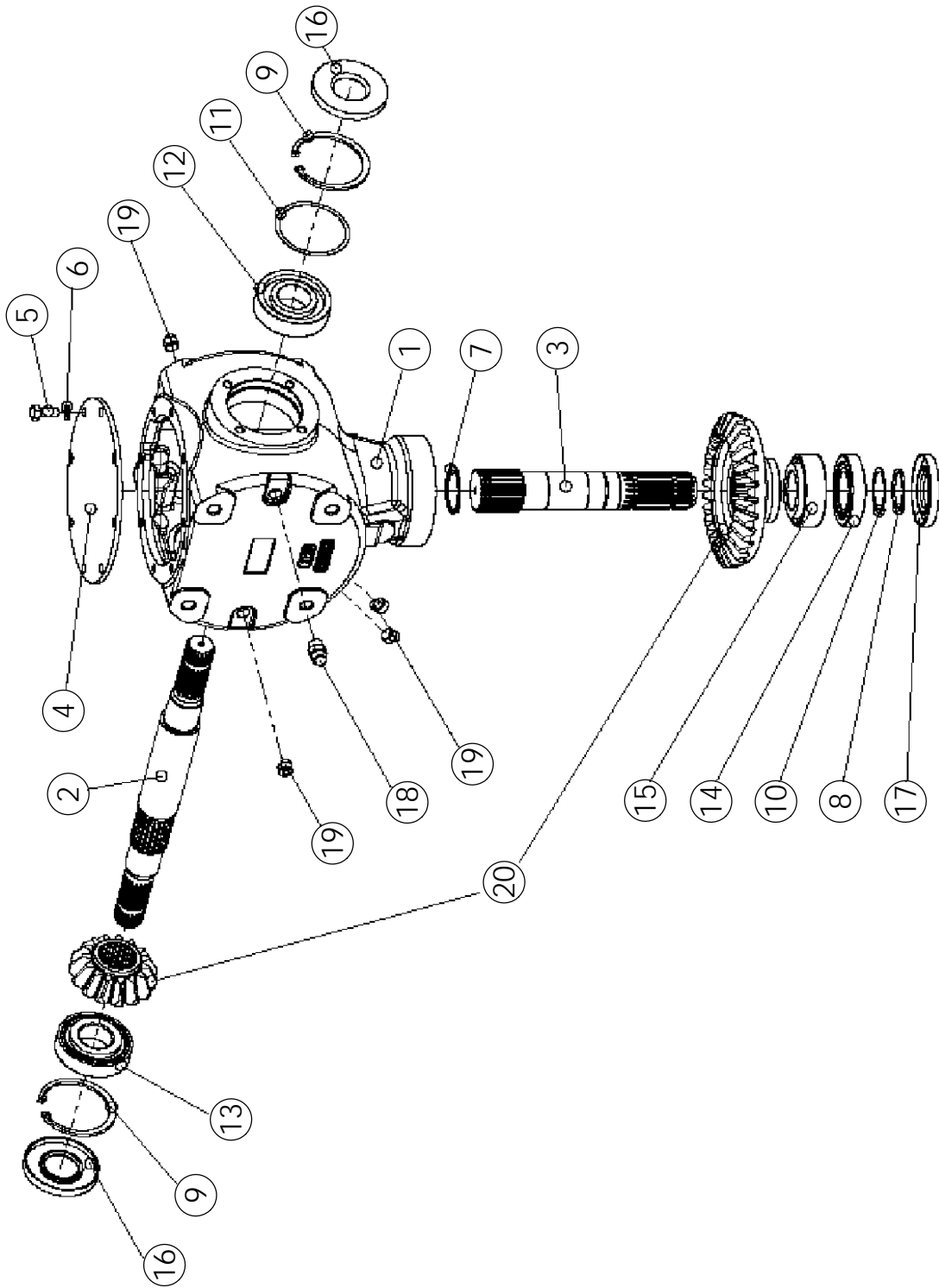

GEARBOX T 1.93:1 #305604

ITEM	PART NO.	DESCRIPTION	QTY
1	305822	HOUSING	1
2	305824	SHAFT	1
3	38194	SHAFT	1
4	68184	SLEEVE	1
5	68185	SCREW-BOLT HEX M10 X25 CL8.8	8
6	68186	WASHER	8
7	52521	SNAP RING: EXTERNAL	1
8	54209	SNAP RING	1
9	305835	INTERNAL SNAP RING 90X4	2
10	64421	KIT-SPACER RING	1
11	305837	SHIM KIT Ø90MM BORE (89.8X80.2)	1
12	305838	BALL BEARING 40X90X23 6308	1
13	305842	T. ROLLER BEARING 40X90X25.25 30308	1
14	54212	BEARING ROLLER	1
15	68187	BEARING-ROLLER	1
16	305843	OIL SEAL 40X90X10	2
17	54214	SEALING RING	3
18	305845	OIL SEAL CAP 90X10	1
19	54215	OIL PLUG	5
20	305847	BEVEL GEAR	1

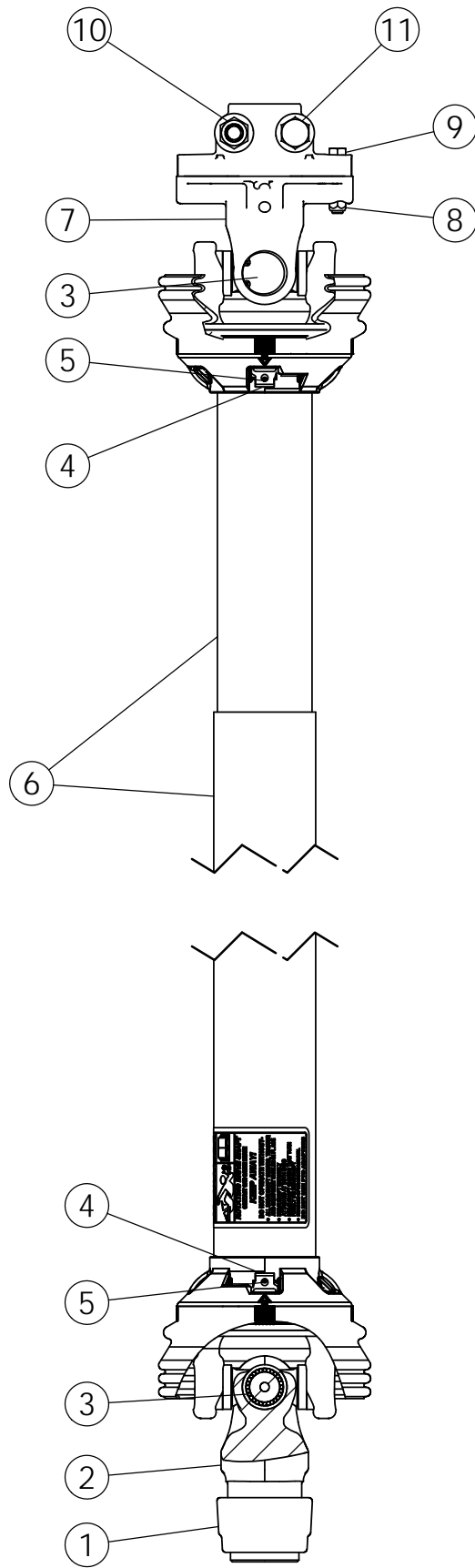

PTO STD DRIVELINE #305691

1.75"-20 SPLINE

ITEM	PART NO.	DESCRIPTION	QTY
1	62123	KT-SAFETY SLIDE LOCK REPAIR 1.750"	1
2	305919	YOKE ASSY-SAFETY SLIDE LOCK 1.750" CAT 6 STD	1
3	305910	KT-CROSS & BEARING 55E SERIES	2
4	64398	KT-NYLON REPAIR UNIVERSAL	2
5	54161	ZERK-DRIVE LUBE FTG (PRESSED IN)	4
6	305917	GUARD SET-STD PTO DEF	1
7	305911	ASSY-BALL SHEAR DEF	1
8	1016999	NUT-TOPLOCK: .38 NC GR5 ZP	1
9	305912	BOLT-HEX: .38 X 2.00 NC GR8 ZP	1
10	305913	NUT-FLG TOPLOCK: .625 NC GR8 ZP	2
11	305914	BOLT-FLG: .625 X 3.50 NC GR8 ZP	2

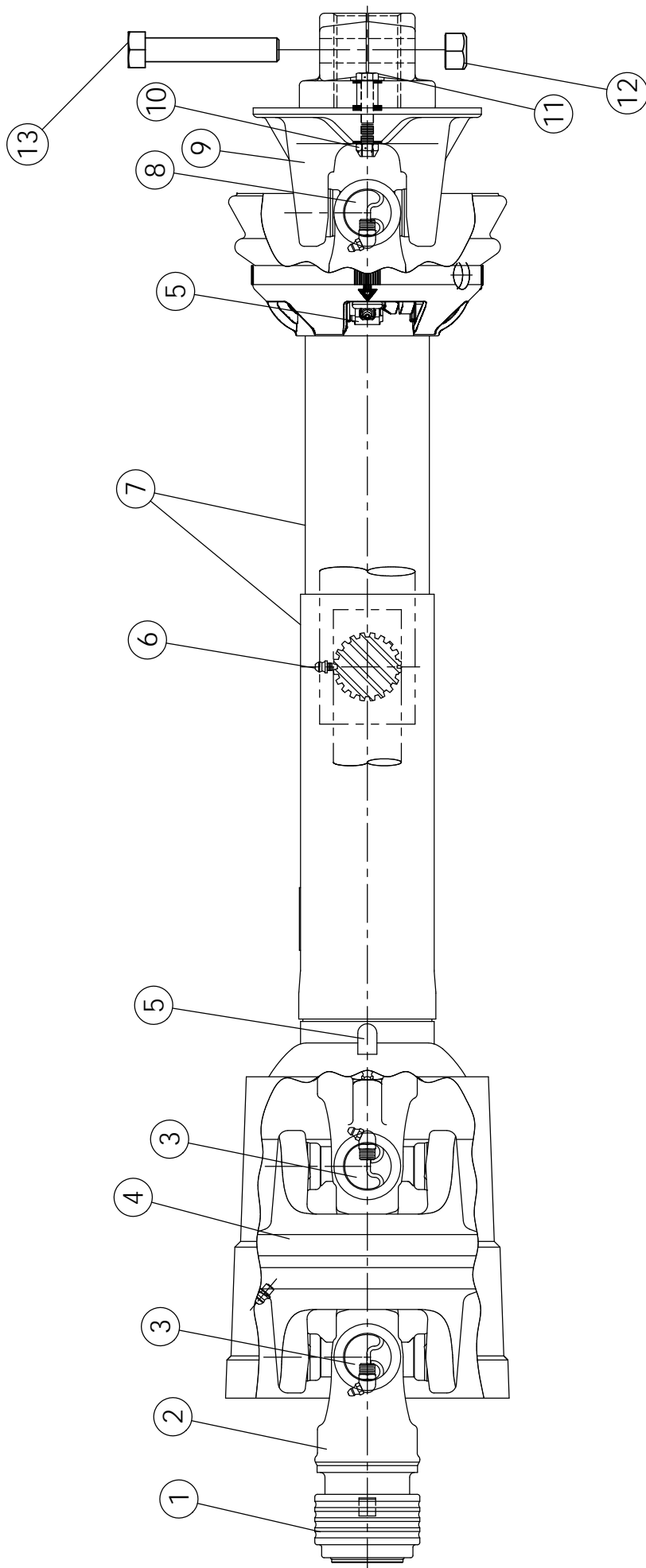

PTO CV DRIVELINE #305690

1.75" - 20 SPLINE

ITEM	PART NO.	DESCRIPTION	QTY
1	62123	KT-SAFETY SLIDE LOCK REPAIR 1.750"	1
2	305902	YOKE ASSY-SAFETY SLIDE LOCK 1.750" CAT 6 CV	1
3	301841	KT-CROSS & BEARING CAT 6	2
4	305904	HOUSING-CV CENTER ASSY CAT 6	1
5	64398	KT-NYLON REPAIR UNIVERSAL	2
6	54161	ZERK-DRIVE LUBE FTG (PRESSED IN)	4
7	305906	GUARD SET-CV PTO DEF	1
8	305910	KT-CROSS & BEARING 55E SERIES	1
9	305911	ASSY-BALL SHEAR DEF	1
10	1016999	NUT-TOPLOCK: .38 NC GR5 ZP	1
11	305912	BOLT-HEX: .38 X 2.00 NC GR8 ZP	1
12	305913	NUT-FLG TOPLOCK: .625 NC GR8 ZP	2
13	305914	BOLT-FLG: .625 X 3.50 NC GR8 ZP	2

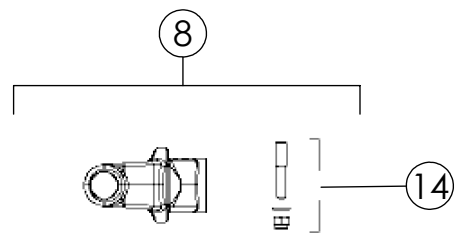
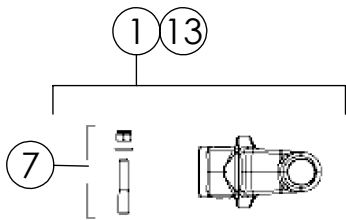
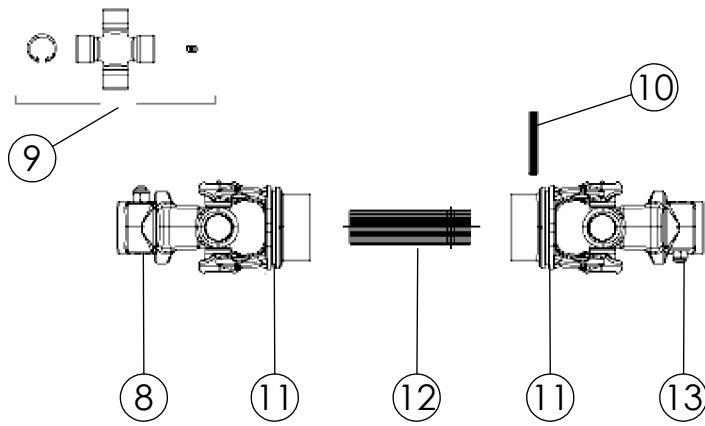
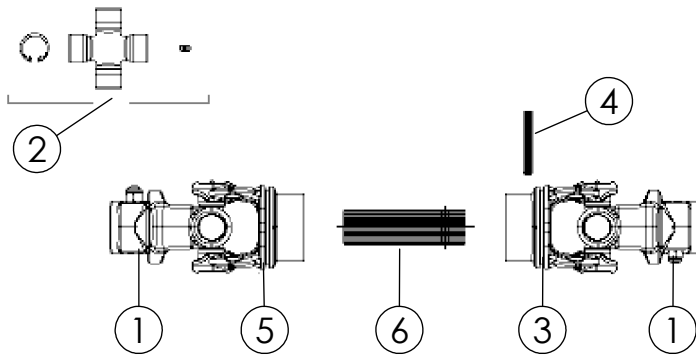

SIDE DRIVELINE #305611

ITEM	PART NO.	DESCRIPTION	QTY
1	305444	YOKE COUPLER TAPER PIN 1.375	2
2	305445	CROSS KIT	2
3	305447	YOKE S9	1
4	305446	PIN-ROLL	1
5	305448	YOKE TUBE-OUTER S9	1
6	305449	TUBE-CARDAN (N/A PURCHASE 305611)	1
7	305546	KIT-TAPER PIN	2

SIDE DRIVELINE #305612

7	305546	KIT-TAPER PIN	1
8	68731	YOKE-COUPLER TAPER PIN 1.750	1
9	305445	CROSS KIT	2
10	305446	ROLL-PIN	1
11	305448	YOKE TUBE-OUTER S9	2
12	305549	TUBE-CARDAN (N/A PURCHASE 305612)	1
13	305444	YOKE-COUPLER TAPER PIN 1.375	1
14	305546	KIT-TAPER PIN	1

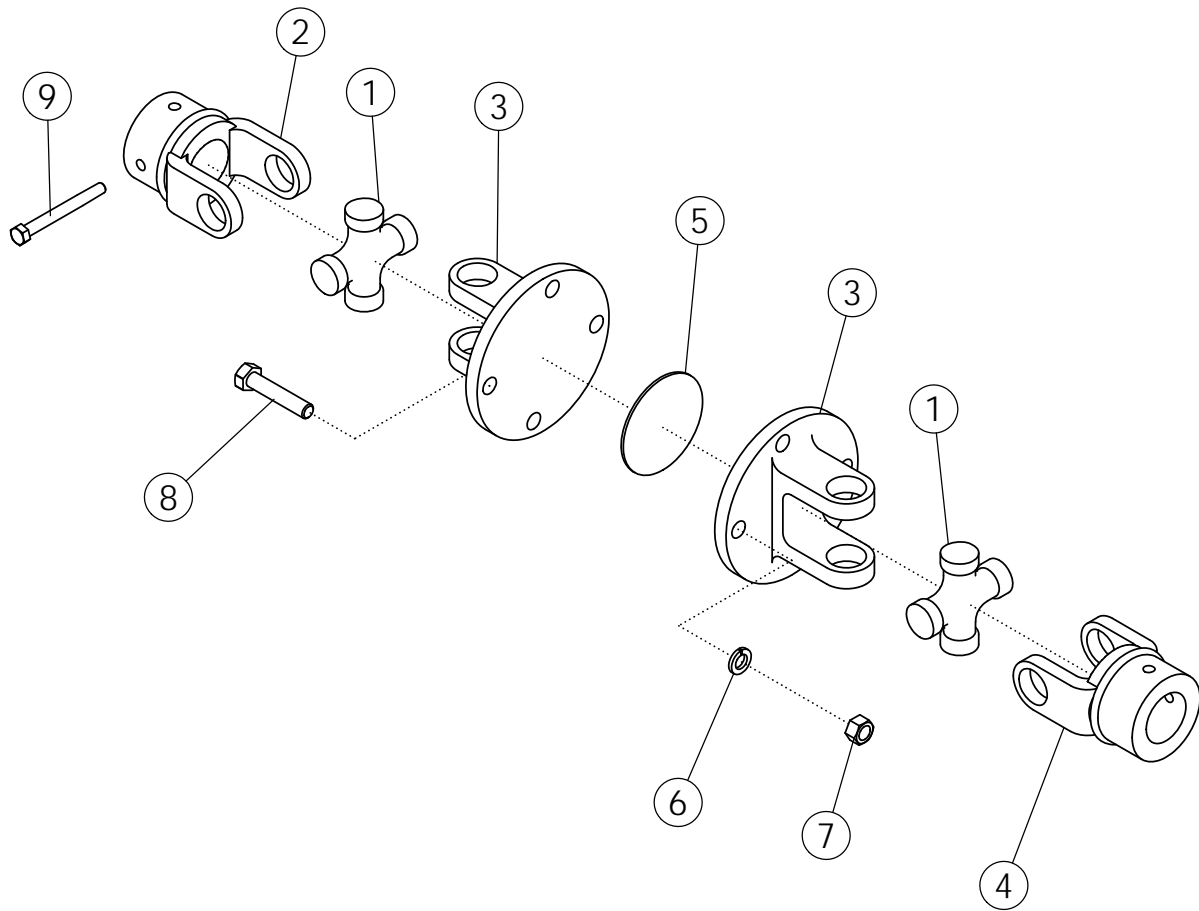

COUPLER-UNIVERSAL JOINT #68443

ITEM	PART NO.	DESCRIPTION	QTY
1	54235	CROSS KIT	2
2	68731	YOKE-COUPLER TAPER PIN 1.750	1
3	68780	FLANGE-YOKE COUPLER	2
4	68732	YOKE COUPLER 1.750	1
5	68781	PLATE-LINER COUPLER	1
6	68591	WASHER-LOCK: M14	4
7	68444	NUT-HEX: M14	4
8	69019	BOLT-HEX: M14 X 2.0 X L50 CL8.8 ZP	4
9	68782	KIT-TAPER PIN 1.750	1

69055 SNAP RING PLIERS

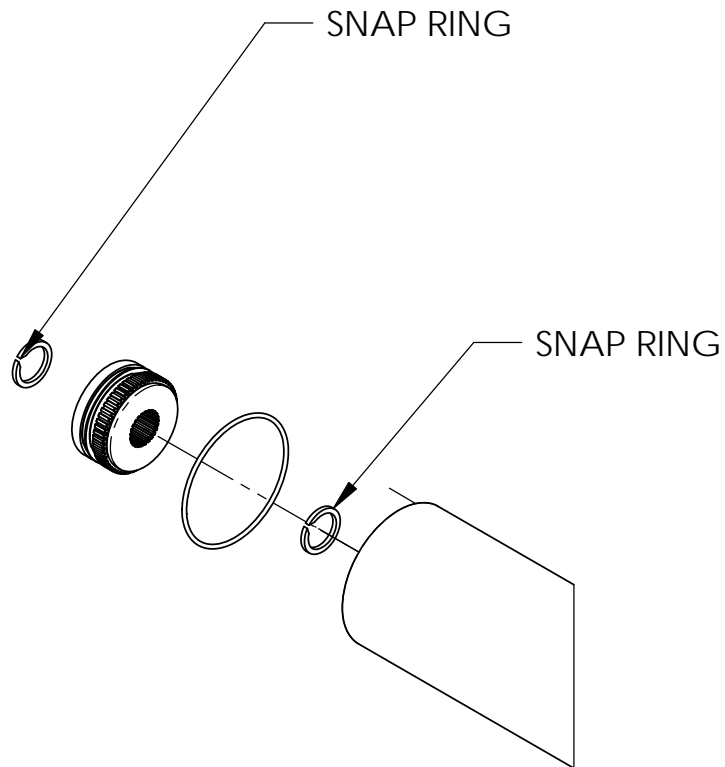
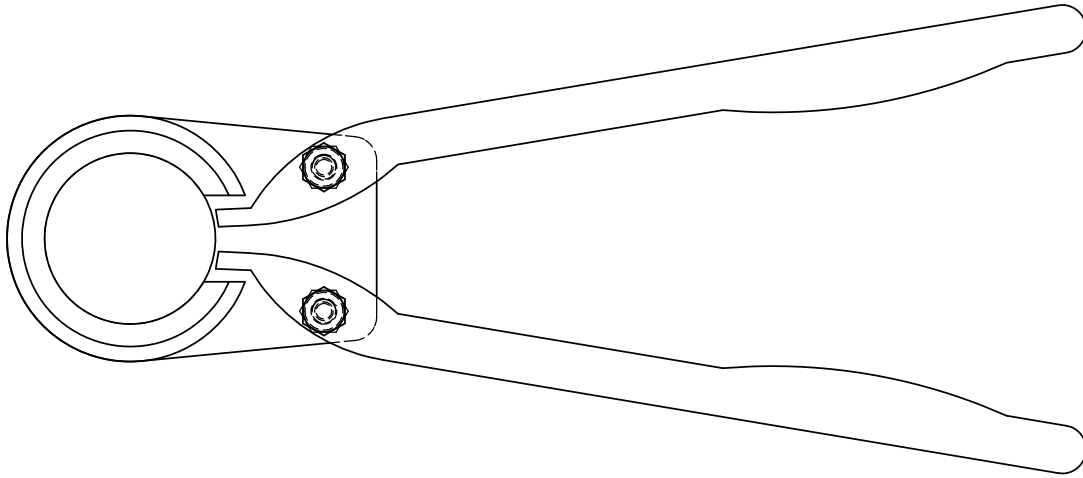

SHAFT REMOVED FOR CLARITY

