

# Amity

TECHNOLOGY

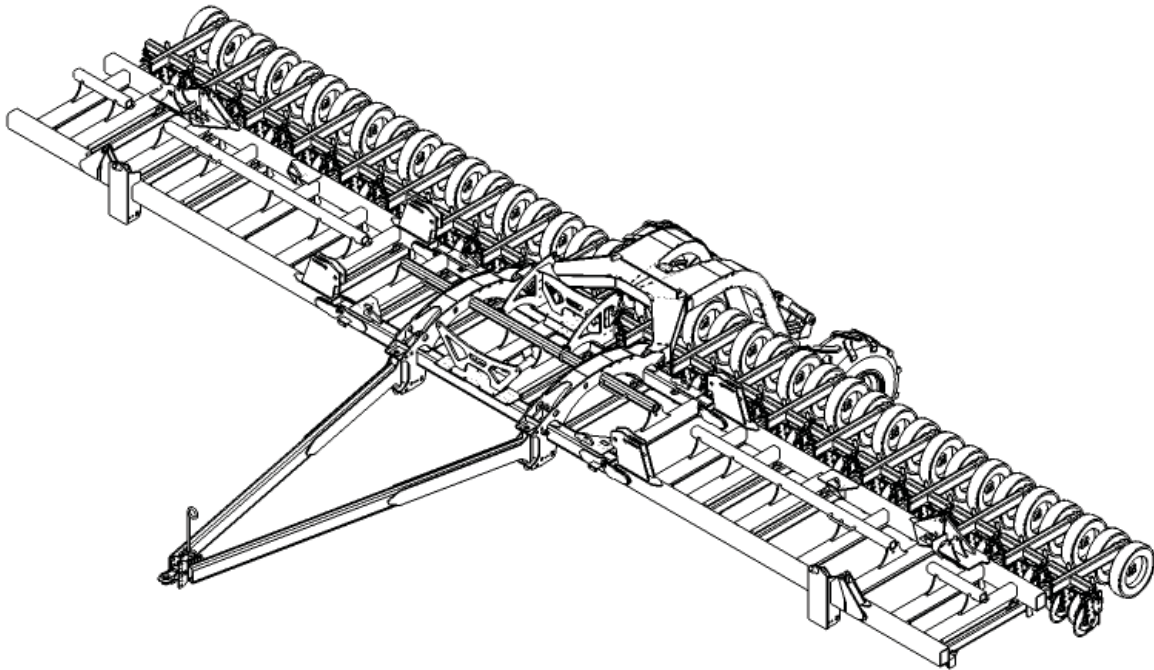

## OPERATING MANUAL



## SINGLE DISC DRILL

Amity Technology, LLC  
2800 7th Avenue North  
Fargo, ND 58102  
(701) 232-4199  
[www.amitytech.com](http://www.amitytech.com)

## **AMITY TECHNOLOGY, LLC LIMITED WARRANTY FOR NEW PRODUCTS**

- 1. General Provisions.** This Warranty shall apply to the original purchaser of (1) any new and unused machine manufactured by Amity Technology, LLC (“Amity”), and (2) any new and unused part which is manufactured by Amity for use in an Amity machine, jointly referred to as “Products,” whether such Product is purchased through a dealer or directly from Amity. Under this Warranty, Amity will repair or replace, as it chooses in its sole discretion, any covered Product, or any component thereof, which Amity determines to be defective. This Warranty shall be in effect for a period of twelve (12) months (“the Warranty Period”), beginning on the date of delivery of the covered machine or part by the dealer or Amity to the purchaser (“the Warranty Start Date”). The purchaser must pay the cost of transportation of a Product to be repaired or replaced to and from an authorized Amity dealer. This Warranty may not be transferred from the original purchaser of a Product to any other person. This Warranty does not give a purchaser the right to any relief other than repair or replacement of the Product, and it specifically does not allow for consequential or incidental damages, exemplary or punitive damages, or costs and fees.
- 2. Scope and Limitations of Warranty.** With respect to machines, this Warranty is void if any part not supplied by Amity is used in assembly or repair of the machine, or if the machine has been altered, abused or neglected, as determined by Amity. With respect to parts, this Warranty is void if the part is used in any manner other than that for which it is intended. This Warranty does not extend in any way to tires and any other component of a Product warranted by another manufacturer, a copy of which warranty is provided herewith (“Third-Party Warranties”). In the event Amity determines that a Product is not defective, or that any other provision of this Paragraph 2 operates to limit the Warranty, this Warranty shall not apply and the purchaser shall be responsible for transporting the Product from the authorized Amity dealer’s location within 10 days of notice by Amity.
- 3. Procedures for Obtaining Service.** To secure Warranty service, a purchaser must (1) report the defect to an authorized dealer and request repair within 45 days of the failure and within the Warranty Period; (2) present evidence that this Warranty applies to the Product; (3) present evidence of the Warranty Start Date; and (4) bring the Product to an authorized Amity dealer within a reasonable period of time after reporting the defect.
- 4. LIMITATION OF IMPLIED WARRANTIES AND OTHER REMEDIES.** To the extent allowed by law, neither Amity, its dealers, nor any company affiliated with Amity makes any warranties, representations, or promises as to the quality, performance, or freedom from defect of any Product covered by this Warranty.

**AMITY HEREBY WAIVES, TO THE EXTENT APPLICABLE, ANY AND ALL IMPLIED WARRANTIES OF MERCHANTABILITY AND FITNESS FOR A PARTICULAR PURPOSE. A PURCHASER’S ONLY REMEDIES IN CONNECTION WITH THIS WARRANTY ARE THOSE SET FORTH ON THIS PAGE. IN NO EVENT WILL AMITY, ITS DEALERS, OR ANY COMPANY AFFILIATED WITH AMITY BE LIABLE FOR INCIDENTAL, CONSEQUENTIAL OR PUNITIVE DAMAGES.**

Some states do not allow waivers of certain warranties, so the above waivers may not apply to you. You may also have other rights which vary from state to state.

- 5. No Dealer Warranty.** This is the exclusive warranty applicable to Amity Products. No dealer has any authority to make any other warranty, modify, limit, or expand the terms of this Warranty in any fashion, or make any representation or promise on behalf of Amity.
- 6. Dispute Resolution.** Any controversy or claim arising out of or relating to this Warranty must be settled by arbitration in Fargo, North Dakota, at a time and location designated by the arbitrator, but not exceeding 30 days after a demand for arbitration has been made, and may be conducted by electronic, video, or other technical means. Arbitration will be conducted by the American Arbitration Association in accordance with its Rules of Commercial Arbitration, and judgment upon the award rendered by the arbitrator may be entered in any court having jurisdiction thereof. The arbitrator will have the authority to order Amity to undertake a repair or replace any Product, at its election, if the arbitrator finds that this Warranty requires Amity to do so. The arbitrator will not have the authority to impose any other remedy against Amity, including without limitation consequential or incidental damages, exemplary or punitive damages, or costs and fees.

# Single Disc Drill

<b>1 Safety</b>	<b>7</b>
<b>1.1 Introduction</b>	<b>9</b>
1.1.1 Safety alert symbol	9
1.1.2 Safety messages	9
1.1.3 Informational messages	9
1.1.4 Safety signs	9
1.1.5 A word to the operator	10
1.1.6 This manual	11
<b>1.2 Operation</b>	<b>12</b>
1.2.1 Prepare for operation	12
1.2.2 Personal protective equipment	12
1.2.3 Agricultural chemicals	12
1.2.4 Travel on public roads	13
<b>1.3 Maintenance</b>	<b>15</b>
1.3.1 Fire prevention and first aid	15
1.3.2 High pressure leaks	16
1.3.3 Tire safety	16
1.3.4 Replacement parts	17
<b>1.4 Wing lock pins</b>	<b>18</b>
1.4.1 Installing wing lock pins	18
1.4.2 Removing wing lock pins	19
<b>1.5 Toolbar locks</b>	<b>20</b>
1.5.1 Locking the toolbar locks	20
1.5.2 Unlocking the toolbar locks	21
<b>1.6 Hydraulic lift assist caster lock pins</b>	<b>23</b>
1.6.1 Locking the hydraulic lift assist caster wheels	23
1.6.2 Unlocking the hydraulic lift assist caster wheels	24
<b>1.7 Hydraulic lock-out valves</b>	<b>25</b>
<b>1.8 Marker lamps</b>	<b>26</b>
<b>1.9 Safety sign location</b>	<b>27</b>
<b>2 Introduction</b>	<b>39</b>
<b>2.1 Introduction</b>	<b>41</b>
2.1.1 Intended use	41
2.1.1.1 Proper disposal of waste	41
<b>2.2 Machine identification</b>	<b>42</b>
2.2.1 Serial number plate	42
2.2.2 Serial number description	42
<b>2.3 Single disc drill</b>	<b>44</b>
<b>2.4 Major components</b>	<b>45</b>
<b>2.5 Operator manual storage</b>	<b>46</b>
<b>3 Operation</b>	<b>47</b>
<b>3.1 ISOBUS Harness Connector</b>	<b>49</b>
<b>3.2 Connecting the drill to the tractor</b>	<b>50</b>
<b>3.3 Disconnecting the drill from the tractor</b>	<b>52</b>
<b>3.4 Preparing the drill for transport</b>	<b>55</b>
<b>3.5 Preparing the drill for seeding</b>	<b>57</b>

<b>3.6 Packing tires</b>	59
3.6.1 Packing tire air pressure	59
<b>3.7 Seed depth</b>	60
3.7.1 Checking the seed depth	60
3.7.2 Seed depth collar sequences	61
3.7.3 Initial seed depth collar sequences	62
3.7.4 Adjusting seed depth	62
<b>3.8 Toolbar down pressure</b>	63
3.8.1 Down pressure control box	63
3.8.2 Setting the toolbar down pressure	64
<b>3.9 Turning at the edge of a field</b>	65
<b>3.10 Hydraulic lift assist</b>	66
3.10.1 Hydraulic lift assist hydraulic caster lock	66
3.10.2 Hydraulic lift assist pressure gauge	66
<b>3.11 NH3 system</b>	68
3.11.1 NH3 menu buttons	68
3.11.2 NH3 system work screen	69
3.11.3 Product on/off buttons	70
3.11.4 Product on/off indicator	70
3.11.5 Target application rate	70
3.11.6 Actual application rate	71
3.11.7 Ground speed	71
3.11.8 Seeding indicator	72
3.11.9 Toolbar position	72
3.11.10 Tank fill percentage	72
3.11.11 Tank size	73
3.11.12 Product density	73
3.11.13 Product weight	73
3.11.14 Applied area counter	74
3.11.15 Applied weight counter	74
3.11.16 Liquid calibration number	74
3.11.17 Calculating the liquid calibration number	74
3.11.18 Verifying the liquid calibration number	75
3.11.19 Purging air from the system	75
3.11.20 NH3 system settings screen	76
3.11.21 Machine width	77
3.11.22 Target flow of the flow-meter	77
3.11.23 Actual flow of the flow-meter	77
3.11.24 Control valve gain	78
3.11.25 Valve polarity	78
3.11.26 Number of valves	78
<b>4 Maintenance</b>	79
<b>4.1 Lubrication and maintenance chart</b>	81
<b>4.2 Grease fitting locations</b>	82
<b>4.3 Leveling the drill frames</b>	86
<b>4.4 Opening disc scraper adjustment</b>	87
4.4.1 Adjusting the opening disc scraper	87
<b>4.5 Opening disc offset</b>	88
4.5.1 Setting opening disc offset	89
<b>4.6 Frame height cylinder phasing</b>	90
4.6.1 Putting the frame height cylinders in phase	90
<b>4.7 Bleeding air from the hydraulic system</b>	91
<b>4.8 Storage</b>	92
4.8.1 Preparing the drill for storage	92

---

4.8.2 Removing the drill from storage . . . . .	92
<b>5 Specifications . . . . .</b>	<b>95</b>
<b>5.1 Specifications . . . . .</b>	<b>97</b>
<b>5.2 Maximum transport speed . . . . .</b>	<b>99</b>
<b>5.3 Frame and rear hitch tire air pressure . . . . .</b>	<b>100</b>
<b>6 Accessories . . . . .</b>	<b>101</b>
<b>6.1 Fertilizer bander attachment . . . . .</b>	<b>103</b>
6.1.1 Adjusting fertilizer bander depth . . . . .	103
<b>7 Assembly . . . . .</b>	<b>105</b>
<b>7.1 Preparing for assembly . . . . .</b>	<b>107</b>
<b>7.2 Assembling the main frame . . . . .</b>	<b>108</b>
7.2.1 Assembling the wings to the main frame . . . . .	108
7.2.2 Assembling the wing extensions to the wing frames . . . . .	109
7.2.3 Assembling the one hub lift wheel . . . . .	113
7.2.4 Assembling the two hub lift wheel . . . . .	115
7.2.5 Installing the lift wheel assembly to the main frame . . . . .	120
7.2.6 Installing the lift wheel assembly to the wing frame and wing extension . . . . .	122
<b>7.3 Installing the toolbars . . . . .</b>	<b>124</b>
7.3.1 Unpacking the toolbars . . . . .	124
7.3.2 Installing and assembling the outer toolbars . . . . .	127
7.3.3 Installing the assembled toolbars . . . . .	133
<b>7.4 Installing the front pull hitch . . . . .</b>	<b>137</b>
<b>7.5 Installing the frame height control hydraulics . . . . .</b>	<b>141</b>
<b>7.6 Installing the work switch sensor . . . . .</b>	<b>149</b>
<b>7.7 Installing the floating rear hitch . . . . .</b>	<b>151</b>
7.7.1 Installing the down pressure hydraulics on the floating rear hitch . . . . .	151
7.7.2 Installing the wing lift hydraulics on the floating rear hitch . . . . .	157
7.7.3 Installing the floating hitch frame to the main frame . . . . .	160
7.7.4 Installing the floating rear hitch wheel assembly . . . . .	161
7.7.5 Installing the bulkhead on the floating rear hitch . . . . .	162
7.7.6 Installing the rear hitch on the floating rear hitch . . . . .	165
7.7.7 Installing the rolling mount flow divider on the floating rear hitch . . . . .	165
7.7.8 Installing the down pressure harness on the floating rear hitch . . . . .	166
7.7.9 Installing the marker lamps and harness on the floating rear hitch . . . . .	167
7.7.10 Installing the main ISO harness on the floating rear hitch . . . . .	174
<b>7.8 Installing the hydraulic lift assist . . . . .</b>	<b>175</b>
7.8.1 Installing the down pressure hydraulics on the hydraulic lift assist . . . . .	175
7.8.2 Installing the wing lift hydraulics on the hydraulic lift assist . . . . .	183
7.8.3 Installing the hydraulic lift assist frame to the main frame . . . . .	188
7.8.4 Assembling the hydraulic lift assist rear axle . . . . .	189
7.8.5 Installing the hydraulic lift assist . . . . .	192
7.8.6 Installing the bulkhead on the hydraulic lift assist . . . . .	196
7.8.7 Installing the rear hitch on the hydraulic lift assist . . . . .	198
7.8.8 Installing the hydraulic caster lock . . . . .	199
7.8.9 Installing the rolling mount flow divider on the hydraulic lift assist . . . . .	200
7.8.10 Installing the down pressure harness on the hydraulic lift assist . . . . .	202
7.8.11 Installing the marker lamps and harness on the hydraulic lift assist . . . . .	202
7.8.12 Installing the main ISO harness on the hydraulic lift assist . . . . .	208
<b>7.9 Installing the secondary flow dividers . . . . .</b>	<b>210</b>
<b>7.10 Installing the dual flow dividers . . . . .</b>	<b>211</b>
7.10.1 Installing the dual hitch mounted flow dividers . . . . .	211
<b>7.11 Installing the wireless blockage monitor system . . . . .</b>	<b>212</b>

7.11.1	Installing the wireless blockage monitor . . . . .	212
7.11.2	Installing the blockage sensors . . . . .	213
7.11.3	Installing the wireless blockage monitor harness . . . . .	215
<b>7.12</b>	<b>Installing the seed delivery system . . . . .</b>	<b>217</b>
7.12.1	Assembling the seed tower manifold . . . . .	217
7.12.2	Installing the 2 zone seed towers . . . . .	218
7.12.3	Installing the 4 zone seed towers . . . . .	221
7.12.4	Routing the seed delivery hoses . . . . .	224
7.12.5	Installing the seed delivery hoses . . . . .	227
<b>7.13</b>	<b>Installing the fertilizer bander . . . . .</b>	<b>228</b>
7.13.1	Installing the fertilizer bander assembly . . . . .	228
7.13.2	Assembling the fertilizer bander with the dry tube . . . . .	228
7.13.3	Assembling the fertilizer bander with the NH3 injector and the dry tube . . . . .	228
<b>7.14</b>	<b>Installing the soybean toolbar . . . . .</b>	<b>229</b>
<b>7.15</b>	<b>Installing safety and information signs . . . . .</b>	<b>230</b>
7.15.1	Installing safety signs . . . . .	230
7.15.2	Installing information signs . . . . .	230
<b>8</b>	<b>Index . . . . .</b>	<b>233</b>

# 1. Safety

<b>1.1 Introduction</b>	<b>9</b>
1.1.1 Safety alert symbol	9
1.1.2 Safety messages	9
1.1.3 Informational messages	9
1.1.4 Safety signs	9
1.1.5 A word to the operator	10
1.1.6 This manual	11
<b>1.2 Operation</b>	<b>12</b>
1.2.1 Prepare for operation	12
1.2.2 Personal protective equipment	12
1.2.3 Agricultural chemicals	12
1.2.4 Travel on public roads	13
<b>1.3 Maintenance</b>	<b>15</b>
1.3.1 Fire prevention and first aid	15
1.3.2 High pressure leaks	16
1.3.3 Tire safety	16
1.3.4 Replacement parts	17
<b>1.4 Wing lock pins</b>	<b>18</b>
1.4.1 Installing wing lock pins	18
1.4.2 Removing wing lock pins	19
<b>1.5 Toolbar locks</b>	<b>20</b>
1.5.1 Locking the toolbar locks	20
1.5.2 Unlocking the toolbar locks	21
<b>1.6 Hydraulic lift assist caster lock pins</b>	<b>23</b>
1.6.1 Locking the hydraulic lift assist caster wheels	23
1.6.2 Unlocking the hydraulic lift assist caster wheels	24
<b>1.7 Hydraulic lock-out valves</b>	<b>25</b>
<b>1.8 Marker lamps</b>	<b>26</b>
<b>1.9 Safety sign location</b>	<b>27</b>





## 1.1 Introduction

### 1.1.1 Safety alert symbol

The safety alert symbol means Attention! Become Alert! Your Safety Is Involved!

Look for the safety alert symbol both in this manual and on safety signs on this machine. The safety alert symbol will direct your attention to information that involves your safety and the safety of others.



Fig. 1

### 1.1.2 Safety messages

The words DANGER, WARNING or CAUTION are used with the safety alert symbol. Learn to recognize these safety alerts and follow the recommended precautions and safety practices.



**DANGER:**

Indicates an imminently hazardous situation that, if not avoided, will result in **DEATH OR VERY SERIOUS INJURY.**



**WARNING:**

Indicates a potentially hazardous situation that, if not avoided, could result in **DEATH OR SERIOUS INJURY.**



**CAUTION:**

Indicates a potentially hazardous situation that, if not avoided, may result in **MINOR INJURY.**



Fig. 2

### 1.1.3 Informational messages

The words important and note are not related to personal safety, but are used to give additional information and tips for operating or servicing this equipment.

**IMPORTANT:** *Identifies special instructions or procedures which, if not strictly observed, could result in damage to or destruction of the machine, process, or its surroundings*

**NOTE:** *Identifies points of particular interest for more efficient and convenient repair or operation.*

### 1.1.4 Safety signs



**WARNING:**

**Do not remove or obscure safety signs. Replace any safety signs that are not readable or are missing. Replacement signs are available from your dealer in the event of loss or damage. The actual location of the safety signs is illustrated at the end of this section.**

Keep signs clean by wiping off regularly. Use a mild soap and water solution if necessary.

If parts have been replaced or a used machine has been purchased, make sure all safety signs are present and in the correct location and can be read. Illustrations of safety sign locations are located at the rear of this section.

Replace any safety signs that can not be read, are damaged, or are missing. Clean the machine surface thoroughly with a mild soap and water solution before replacing signs. Replacement safety signs are available from your dealer.

### 1.1.5 A word to the operator

---

It is your responsibility to read and understand the safety section in this manual and the manual for all attachments before operating this machine. Remember you are the key to safety. Good safety practices not only protect you, but also the people around you.

Study the content in this manual and make the content a working part of your safety program. Keep in mind that this safety section is written only for this type of machine. Practice all other usual and customary safe working precautions, and above all remember - safety is your responsibility. You can prevent serious injury or death.

This safety section is intended to point out some of the basic safety situations that may be encountered during the normal operation and maintenance of your machine. This section also suggests possible ways of dealing with these situations. This section is not a replacement for other safety practices featured in other sections of this manual.

Personal injury or death may result if these precautions are not followed.

Learn how to operate the machine and how to use the controls properly.

Do not let anyone operate the machine without instruction and training.

For your personal safety and the personal safety of others, follow all safety precautions and instructions found in the manuals and on safety signs affixed to the machine and all attachments.

Use only approved attachments and equipment.

Make sure your machine has the correct equipment needed by the local regulations.

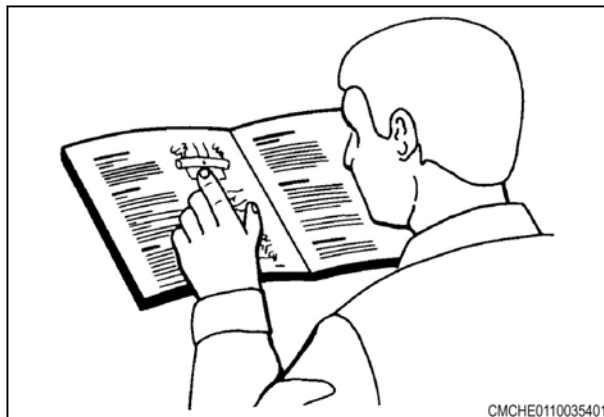

Fig. 3



**WARNING:**

**An operator should not use alcohol or drugs which can affect their alertness or coordination. An operator on prescription or 'over the counter' drugs needs medical advice on whether or not they can properly operate machines.**



**CAUTION:**  
If any attachments used on this equipment have a separate Operator Manual, see that manual for other important safety information.

---

### 1.1.6 This manual

---

This manual covers general safety practices for this machine. The operator manual must always be kept with the machine.

Right-hand and left-hand, as used in this manual, are determined by facing the direction the machine will travel when in use.

The photos, illustrations, and data used in this manual were current at the time of printing, but due to possible in-line production changes, your machine can vary slightly in detail. The manufacturer reserves the right to redesign and change the machine as necessary without notification.



**WARNING:**  
In some of the illustrations and photos used in this manual, shields or guards may have been removed for clarity. Never operate the machine with any shields or guards removed. If the removal of shields or guards is necessary to make a repair, they must be replaced before operation.

## 1.2 Operation

---

### 1.2.1 Prepare for operation

---

Read and understand all operating instructions and precautions in this manual before operating or servicing the machine.

Make sure you know and understand the positions and operations of all controls. Make certain all controls are in neutral and the park brake is applied before starting the machine.

Make certain all people are well away from your area of work before starting and operating the machine. Check and learn all controls in an area clear of people and obstacles before starting your work. Be aware of the machine size and have enough space available to allow for operation. Never operate the machine at high speeds in crowded places.

Emphasize the importance of using correct procedures when working around and operating the machine. Do not let children or unqualified persons operate the machine. Keep others, especially children, away from your area of work. Do not permit others to ride on the machine.

Make sure the machine is in the proper operating condition as stated in the Operator Manual. Make sure the machine has the correct equipment required by local regulations.

### 1.2.2 Personal protective equipment

---

Wear all personal protective equipment (PPE) and protective clothing issued to you or called for by job conditions and country/local regulations. PPE includes, but is not limited to, equipment to protect eyes, lungs, ears, head, hands and feet when operating, servicing, or repairing equipment.

Always keep hands, feet, hair, and clothing away from moving parts. Do not wear loose clothing, jewelry, watches, or other items that could entangle in moving parts. Tie up long hair that can also entangle in moving parts.

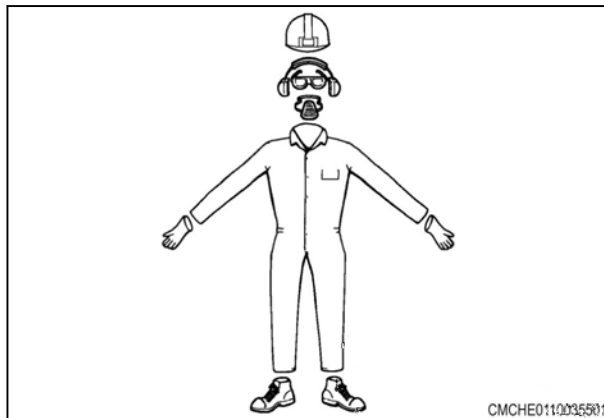

Fig. 4

### 1.2.3 Agricultural chemicals

---

Agricultural chemicals can be very hazardous. Improper use of fertilizer, fungicides, herbicides, insecticides and pesticides can injure people, plants, animals, soil and other people's property.

Always read and follow all manufacturers' instructions before opening any chemical container.

Even if you think you know the instructions, read and follow instructions each time you use a chemical.

Use the same precautions when adjusting, servicing, cleaning or storing the machine as used when installing chemicals into the hoppers or tanks.

Inform anyone who comes in contact with chemicals of the potential hazards involved and the safety precautions required.

Stand upwind and away from smoke from a chemical fire.

Store or dispose of all unused chemicals only in a manner as specified by the chemical manufacturer.

## 1.2.4 Travel on public roads

Make sure you understand the speed, brakes, steering, stability, and load characteristics of this machine before you travel on public roads.

Use good judgment when traveling on public roads. Maintain complete control of the machine at all times. Never coast down hills.

The maximum speed of farm equipment is governed by local regulations. Adjust travel speed to maintain control at all times.

Familiarize yourself with and obey all road regulations that apply to your machine. Consult your local law enforcement agency for local regulations regarding movement of farm equipment on public roads. Use head lamps, flashing warning lamps, tail lamps and turn signals, day and night, unless prohibited by local law.

Make sure all the flashers are operating prior to driving on the road. Make sure reflectors are correctly installed, in good condition, and wiped clean. Make sure the Slow Moving Vehicle (SMV) emblem is clean, visible, and correctly mounted on the rear of the machine.

Always travel with the loader as low as possible. Do not drive with loader up.

Lock brake pedals together (if equipped with dual brake pedals) so both wheel brakes will be applied at the same time.

Raise implements to transport position and lock in place. Place all implements into narrowest transport configuration.

Disengage the power take-off and differential lock.

With towed implements, use a proper hitch pin with a clip retainer and safety transport chain.

Be aware of other traffic on the road. Keep well over to your own side of the road and pull over, whenever possible, to let faster traffic pass.

Be aware of the overall width, length, height, and weight of the machine. Be careful when transporting the machine on narrow roads and across narrow bridges.

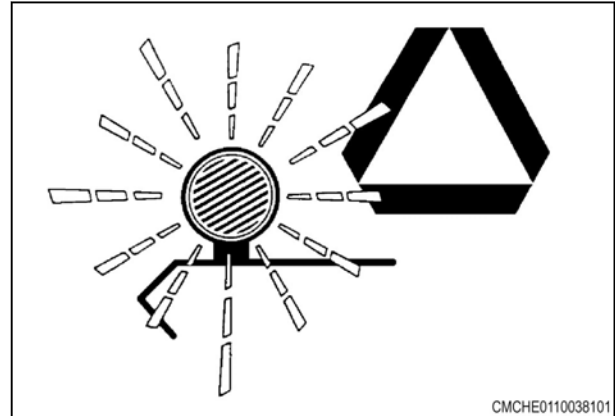

Fig. 5

CMCHE0110038101

Watch for overhead wires and other obstructions. Avoid contact with electrical power lines. Contact with electrical power lines can cause electrical shock, resulting in very serious injury or death.

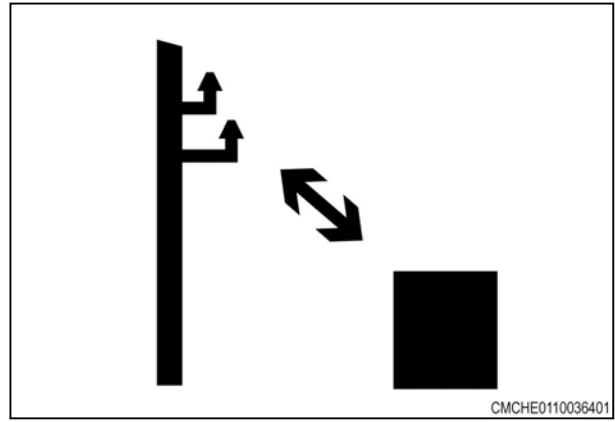

Fig. 6

## 1.3 Maintenance

### 1.3.1 Fire prevention and first aid

Be prepared for emergencies.

Keep a first aid kit handy for treatment of minor cuts and scratches.

Always carry one or more fire extinguishers of the correct type. Check fire extinguishers regularly as instructed by the manufacturer. Make sure fire extinguishers are properly charged and in operating condition.

Due to the nature of the crops this machine will operate in, the risk of fire is of concern. Use a water type fire extinguisher or other water source for a fire in crop.

For fires involving anything other than crop, such as oil or electrical components, use a dry chemical fire extinguisher with an ABC rating.

Mount fire extinguishers within easy reach of where fires can occur.

Frequently remove accumulated crop material from the machine and check for overheated components. Check the machine daily for any noises that are not normal. Such noises could indicate a failed component that can cause excess heat.

If any flame cutting, welding, or arc welding is to be done on the machine or attachments, make sure to clear any crop material or debris from around the area. Make sure the area below the work area is clear of any flammable material as falling molten metal or sparks can ignite the material.

If fire occurs stand upwind and away from smoke from the fire.



Fig. 7



Fig. 8

### 1.3.2 High pressure leaks

Fluid leaking from the hydraulic system or the fuel injection system under high pressure can be very hard to see. The fluid can go into the skin causing serious injury.

Fluid injected into the skin must be surgically removed within a few hours. If not removed immediately, serious infection or reaction can develop. Go immediately to a doctor who knows about this type of injury.



Fig. 9

Use a piece of cardboard or wood to search for possible leaks. Do not use your bare hand. Wear leather gloves for hand protection and safety goggles for eye protection.

Relieve all pressure before loosening any hydraulic lines. Relieve the pressure by lowering raised equipment, shutting off accumulator valve, if equipped, and shutting off the engine. Tighten all connections securely before applying pressure.

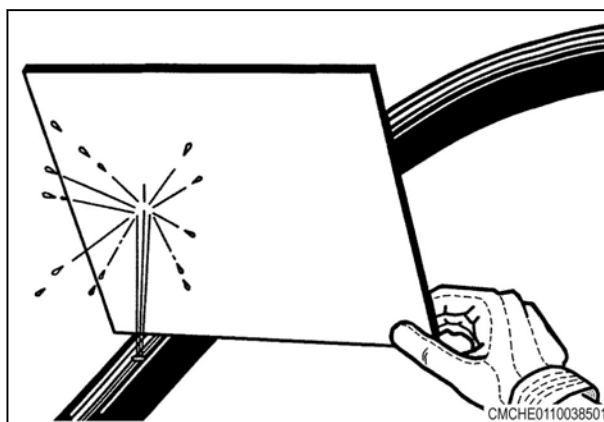

Fig. 10

### 1.3.3 Tire safety

Check tires for cuts, bulges, and correct pressure. Replace worn or damaged tires. When tire service is needed, have a qualified tire mechanic service the tire. Tire changing can be very hazardous and must be done by qualified tire mechanic using proper tools and equipment. See the Specifications Section for the correct tire size.

Tire explosion and/or serious injury can result from over inflation. Do not exceed the tire inflation pressures. See the Specifications Section for the correct tire pressure.

Do not inflate a tire that is seriously under inflated or has been run flat. Have the tire checked by qualified tire mechanic.

Do not weld on the rim when a tire is installed. Welding will make an air/gas mixture that can cause an explosion and burn with high temperatures. This danger applies to all tires, inflated or deflated. Removing air or breaking the bead is not enough. The tire must be completely removed from the rim prior to welding.



Fig. 11



When preparing a calcium chloride solution for fluid ballast the tractor tires, never pour water onto the calcium chloride. A chlorine gas can be generated which is poisonous and explosive. This can be avoided by slowly adding calcium chloride flakes to water and stirring until they are dissolved.

When seating tire beads onto rims, never exceed 2.4 bar (35 psi) or the maximum inflation pressure specified on the tire. Inflation beyond this maximum pressure may break the bead, or even the rim, with explosive force.

### 1.3.4 Replacement parts

Where replacement parts are necessary for periodic maintenance and servicing, genuine replacement parts must be used to restore your equipment to original specifications.

The manufacturer will not accept responsibility for installation of unapproved parts and/or accessories and damages as a result of their usage.

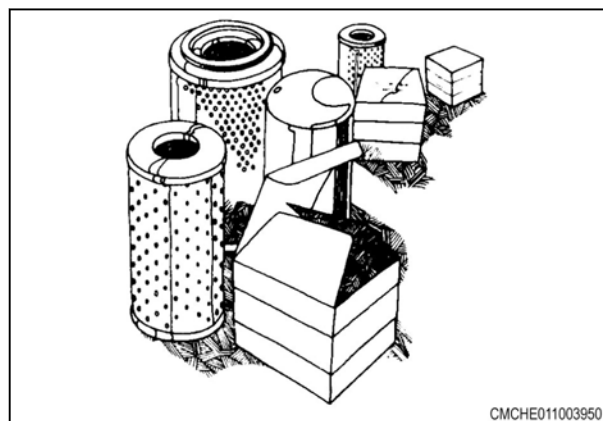

Fig. 12

## 1.4 Wing lock pins

The drill is equipped with four wing lock pins. The wing lock pins are used to lock the wings in the raised or folded position. Install the wing lock pins when transporting or servicing the drill.

When unlocking the wings, keep the wing lock pins (1) in the brackets (2) located on the main frame. The wing lock brackets are located at the hinge points of each wing.

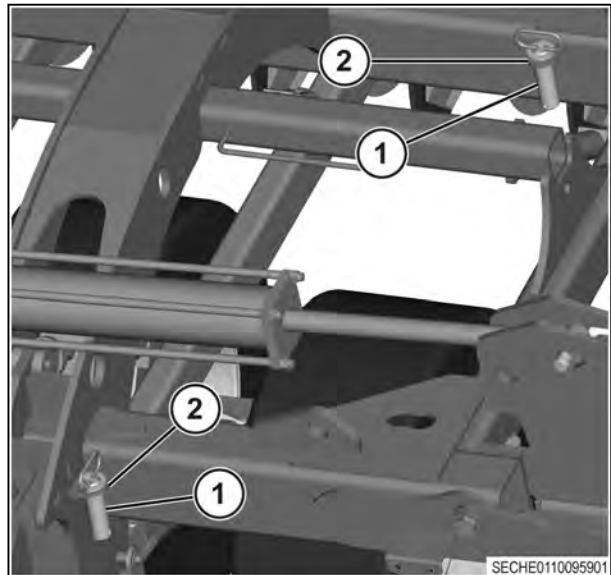

Fig. 13

### 1.4.1 Installing wing lock pins

Install the wing lock pins whenever the drill is to be transported or serviced with the wing in the raised or folded position.

#### Procedure

1. Use the tractor hydraulics to fully lift the wings of the drill.
2. Stop the engine, set the tractor park brake, and take the ignition key with you.
3. Remove the keeper pin from the end of the wing lock pin. Remove the wing lock pin (1) from the storage bracket (2).

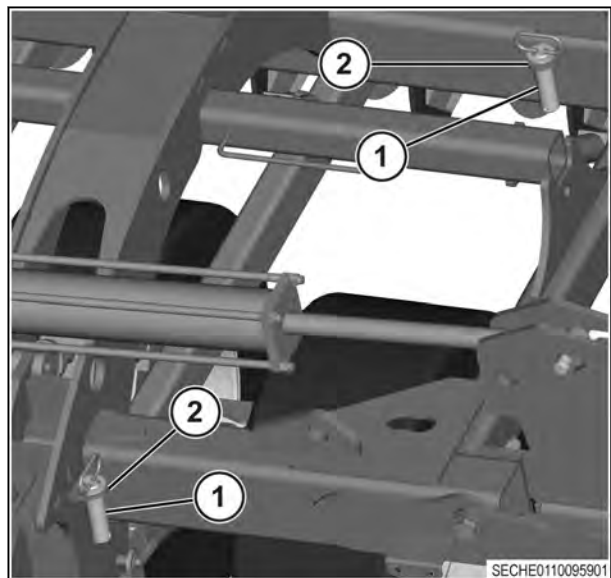

Fig. 14

4. Install the wing lock pin (1) through the holes in the wing lock brackets (2). Install the keeper pin in the end of the wing lock pin.
5. Use the same procedure to install the remaining wing lock pins in the wing lock brackets on the remaining hinge points.

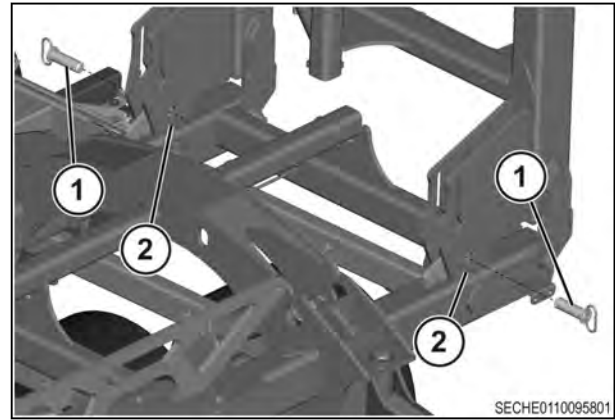

Fig. 15

### 1.4.2 Removing wing lock pins

Remove the wing lock pins before dropping the wings of the drill.

#### Procedure

1. Use the tractor hydraulics to remove any load from the wing lock pins by completely raising the wings.
2. Stop the engine, set the tractor park brake, and take the ignition key with you.
3. Remove the keeper pin from the end of the wing lock pin. Remove the wing lock pin (1) from the wing lock brackets (2).

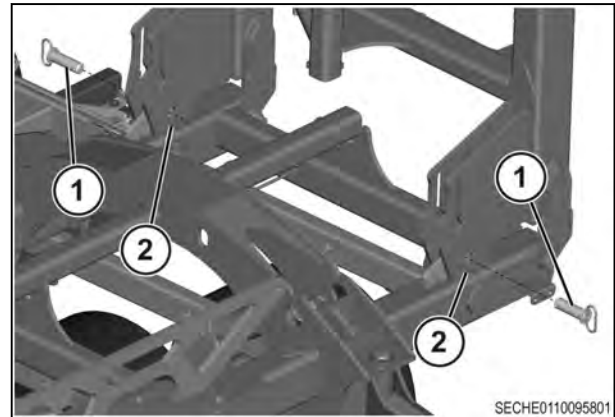

Fig. 16

4. Install the wing lock pin (1) in the storage bracket (2) on the main frame of the drill. Install the keeper pin in the end of the wing lock pin.
5. Remove the remaining wing lock pins from the wing lock brackets of the remaining hinge points.
6. Use the tractor hydraulics to lower the wings to the ground.

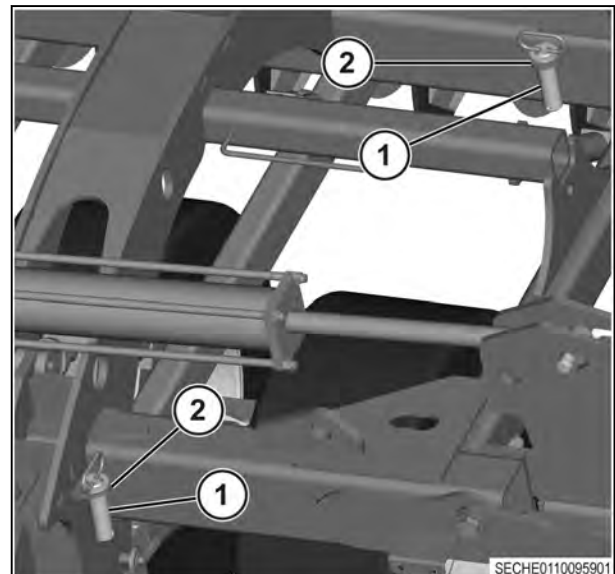

Fig. 17

## 1.5 Toolbar locks

Each toolbar is equipped with a toolbar lock (1). The toolbar locks are used to lock the toolbars in the raised position. Engage the toolbar locks when transporting the drill or servicing the toolbars in the raised position.

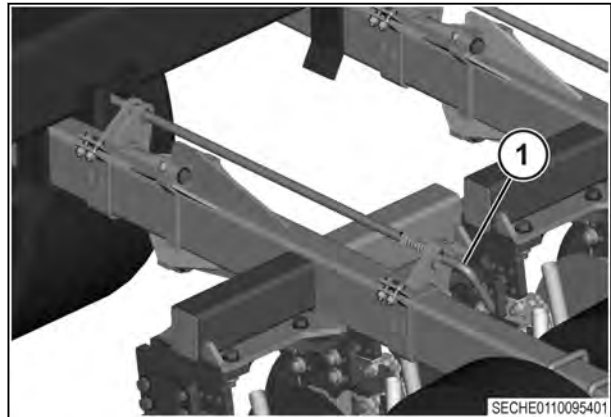

Fig. 18

Two roll pins are installed in the toolbar lock handle (1). The first roll pin (2) secures the toolbar lock handle in the unlocked position. The second roll pin (3) secures the toolbar lock handle in the locked position.

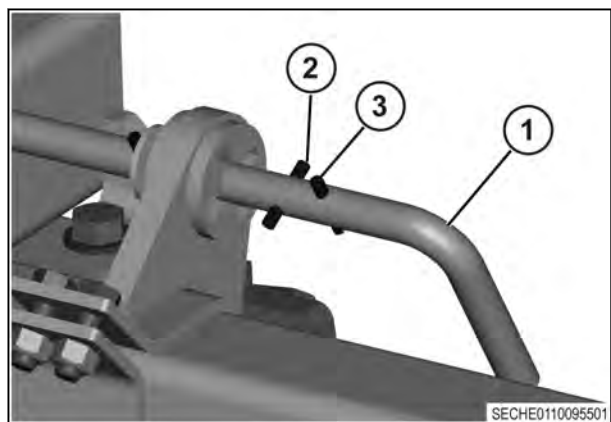

Fig. 19

When in the locked position, the toolbar lock handle (1) engages in a lock bracket (2) on the frame of the drill.

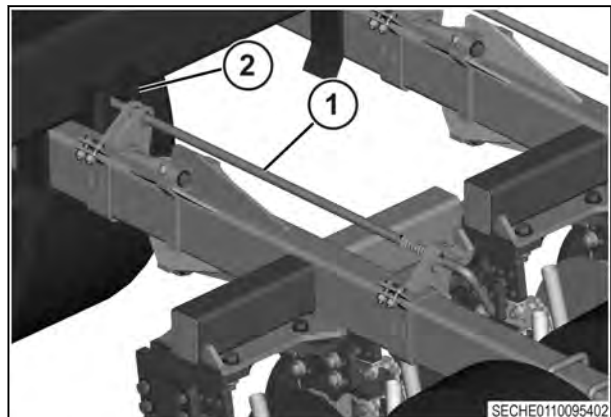

Fig. 20

### 1.5.1 Locking the toolbar locks

Lock the toolbars before transporting the drill or servicing the toolbars.

#### Procedure

1. Use the tractor hydraulics to completely raise the toolbars.
2. Stop the engine, set the tractor park brake, and take the ignition key with you.

3. Pull the toolbar lock handle (1) straight back until the first roll pin (2) is clear of the lock groove (3) in the handle support.

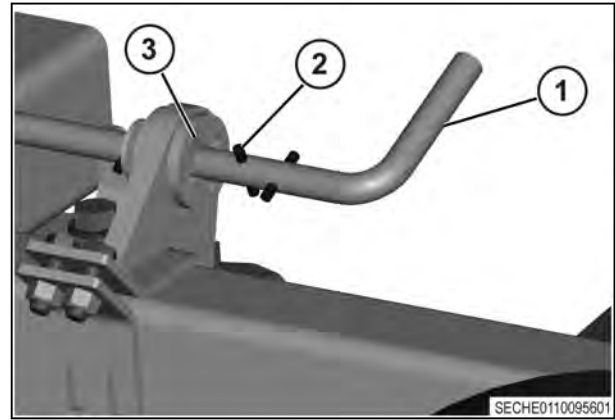

Fig. 21

4. Twist the toolbar lock handle (1) until the first roll pin (2) aligns with the groove (3) that passes through the handle support. Allow the handle spring to pull the toolbar lock handle until the first roll pin passes through the handle support.

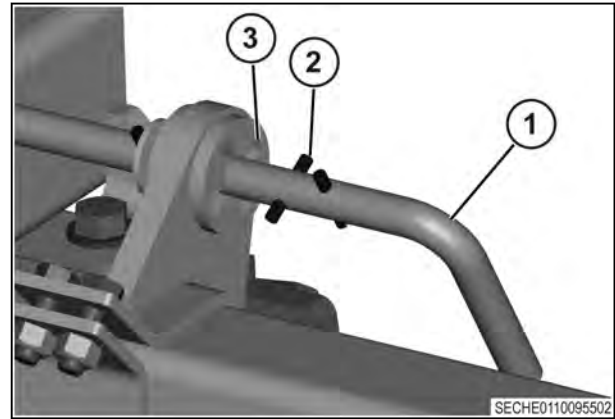

Fig. 22

5. Twist the toolbar lock handle (1) until the second roll pin aligns with the lock groove (2) in the handle support. Allow the handle spring to pull the toolbar lock handle until the second roll pin is engaged in the lock groove in the handle support.

**IMPORTANT:** Make sure the toolbar lock handle is fully engaged with the lock bracket (3) on the frame of the drill.

6. Use the same procedure to lock the remaining toolbars on the drill.

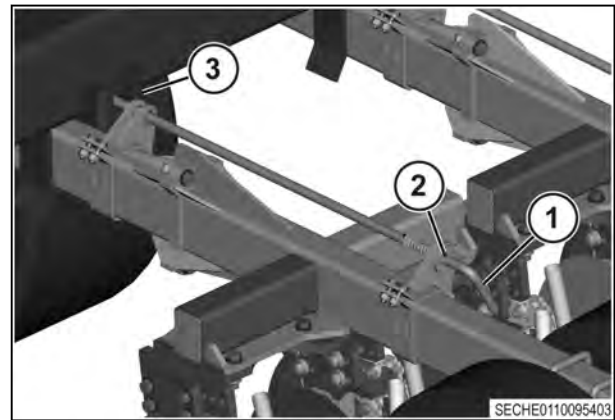

Fig. 23

## 1.5.2 Unlocking the toolbar locks

Unlock the toolbars before operating the drill in the field.

### Procedure

1. Use the tractor hydraulics to remove any load from the toolbar locks by completely raising the toolbars.
2. Stop the engine, set the tractor park brake, and take the ignition key with you.

3. Pull the toolbar lock handle (1) until the second roll pin (2) is clear of the lock groove (3) in the handle support.

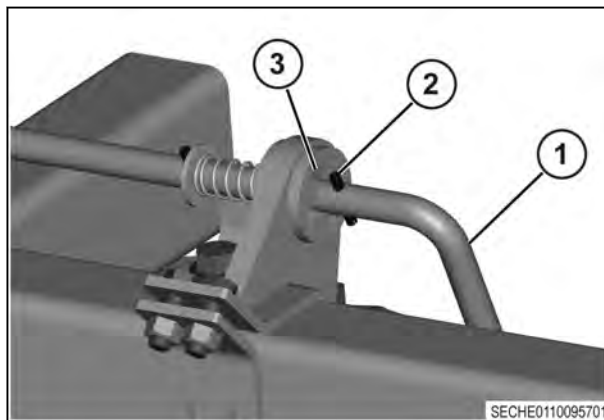

Fig. 24

4. Turn the toolbar lock handle (1) until the first roll pin (2) aligns with the groove (3) that moves through the handle support. Pull the toolbar lock handle until the first roll pin moves through the handle support.

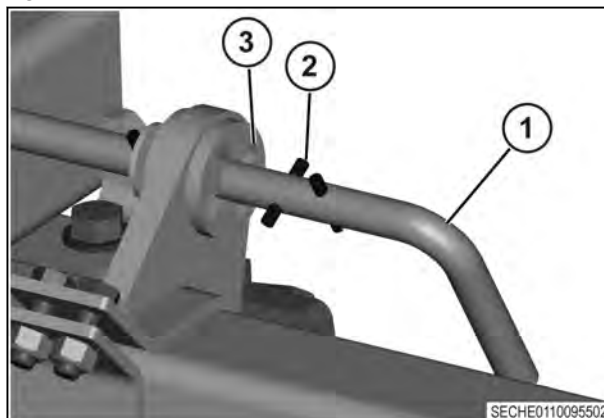

Fig. 25

5. Turn the toolbar lock handle (1) until the first roll pin (2) aligns with the lock groove (3) in the handle support. Let the handle spring pull the toolbar lock handle until the first roll pin engages the lock groove in the handle support.

**IMPORTANT:** Make sure the toolbar lock handle is clear of the lock bracket on the frame of the drill.

6. Use the same procedure to unlock the remaining toolbars on the drill.

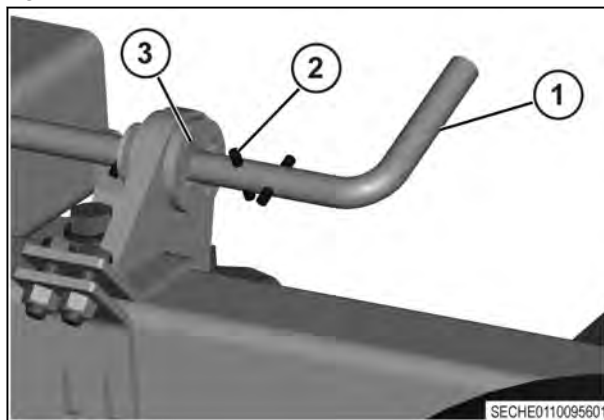

Fig. 26

## 1.6 Hydraulic lift assist caster lock pins

The hydraulic lift assist rear hitch is equipped with caster lock pins (1). Use the caster lock pins to lock the caster wheels (2) in the straight forward position. Lock the caster wheels when transporting the machine.

When the unlocking the caster, keep the caster lock pins in the brackets (3) located on the rear of the outer axles. The caster lock brackets (4) are located on the front of the outer axles.

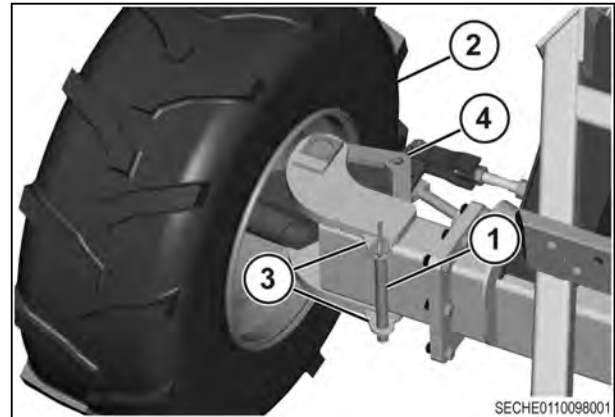

Fig. 27

### 1.6.1 Locking the hydraulic lift assist caster wheels

The caster wheels on the hydraulic lift assist rear hitch must be locked before the machine can be transported.

#### Procedure

1. Use the tractor hydraulics to raise the frame of the drill to the highest position.
2. Pull the drill forward until both caster wheels are pointing straight forward.
3. Stop the tractor. Stop the engine, apply the tractor park brake, and take the ignition key with you.
4. On the hydraulic lift assist hitch, remove the caster wheel lock pins (1) from the storage brackets (2) on the rear of the outer axle.

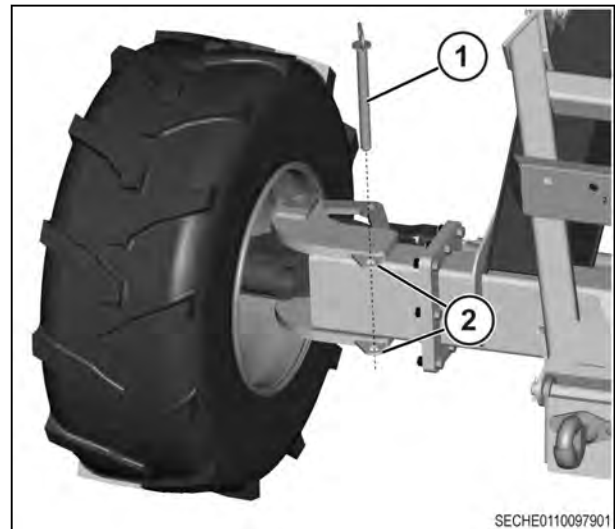

Fig. 28

5. Install the caster wheel lock pins (1) through the holes of the caster wheel lock brackets (2) on the front of the outer axle.
6. Use the same procedure to lock the caster wheel on the opposite outer axle.

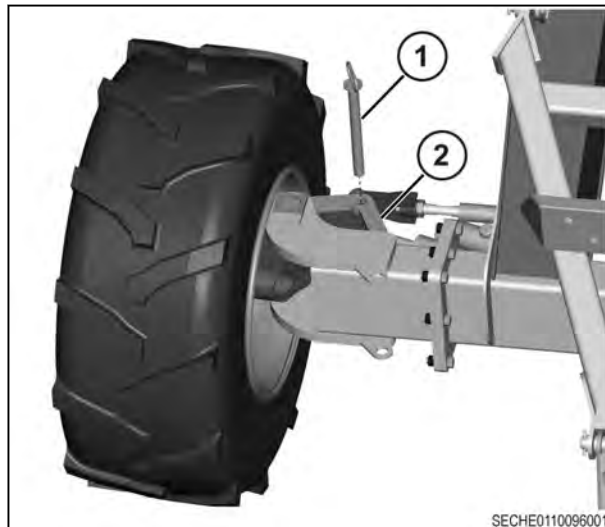

Fig. 29

### 1.6.2 Unlocking the hydraulic lift assist caster wheels

The hydraulic lift assist caster wheels must be unlocked before the drill can be operated in the field.

1. Remove the caster lock pins (1) from the caster lock brackets (2) on the front of the outer axle.

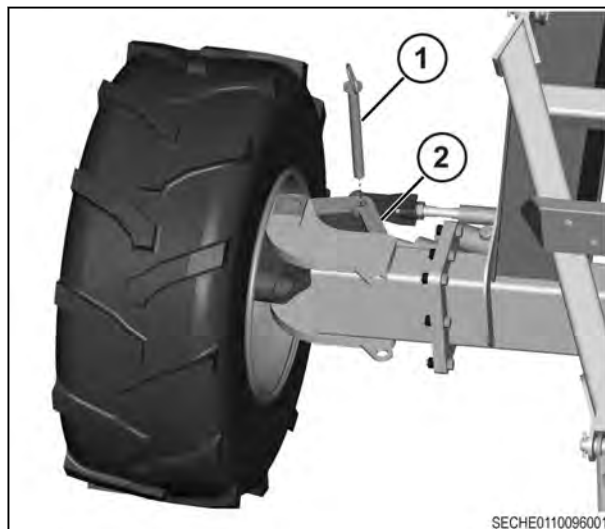

Fig. 30

2. Install the caster lock pins (1) in the storage brackets (2) on the rear of the outer axle.
3. Use the same procedure to unlock the caster wheel on the opposite outer axle.

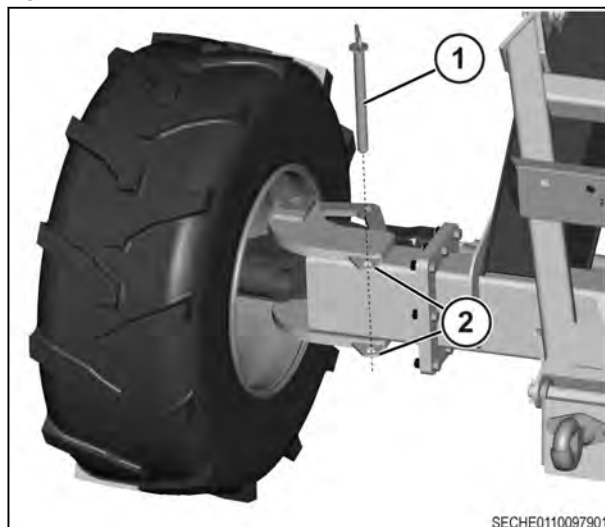

Fig. 31



## 1.7 Hydraulic lock-out valves

The hydraulic lock-out valves are located on the front of the frame, toward the left-hand side of the front hitch.

The toolbar lock-out valve (1) is installed on all drills. The toolbar lock-out valve is used to hydraulically lock the toolbars in the transport or up position.



### WARNING:

**The toolbars can drop to the ground when the toolbar lock-out valve is opened. Make sure the area below the toolbars is clear of people and obstructions before opening the toolbar lock-out valve.**

On drills equipped with a hydraulic lift assist hitch, a hydraulic lift assist lock-out (2) is installed to the right-hand side of the toolbar lock-out. Use the hydraulic lift assist lock-out when transporting the drill and the drill is in storage.

Move the valve handle so the handle is parallel to the frame to put the lock-out valve in the open position (1). In the open position hydraulic pressure can flow through the valve.

Move the valve handle down to put the lock-out valve in the closed position (2). In the closed position the hydraulic pressure will not flow through the valve.

**IMPORTANT:** *Open both valves when seeding and close both valves when transporting the drill.*

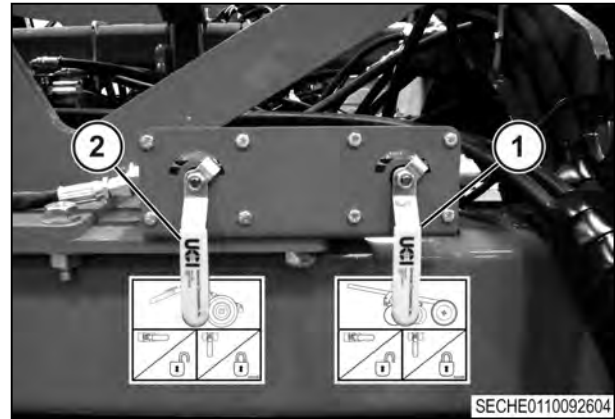

Fig. 32

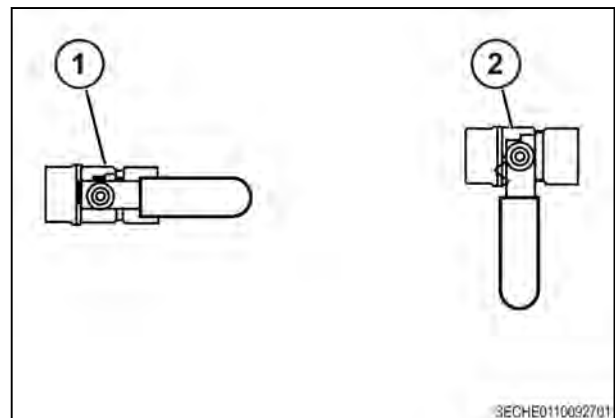

Fig. 33

## 1.8 Marker lamps

The machine is equipped with marker lamps and reflectors that must be used when transporting the machine on public roads.

The front of the machine is equipped with two amber lamps (1) located at the outside edges of the frame.

The rear of the machine is equipped with two red lamps (2) located on the rear hitch.

The machine is equipped with reflectors that must be visible when transporting the machine on public roads. See the safety sign location information for the location of these reflectors.

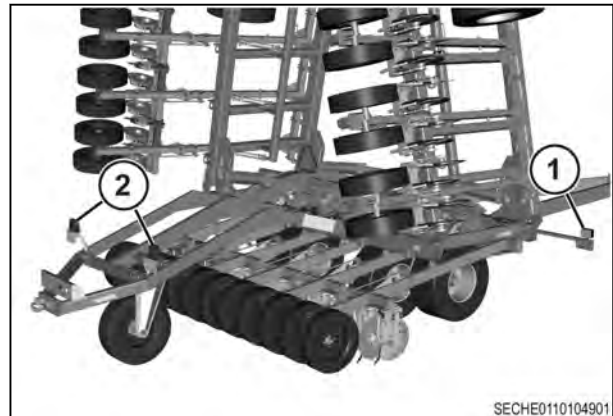
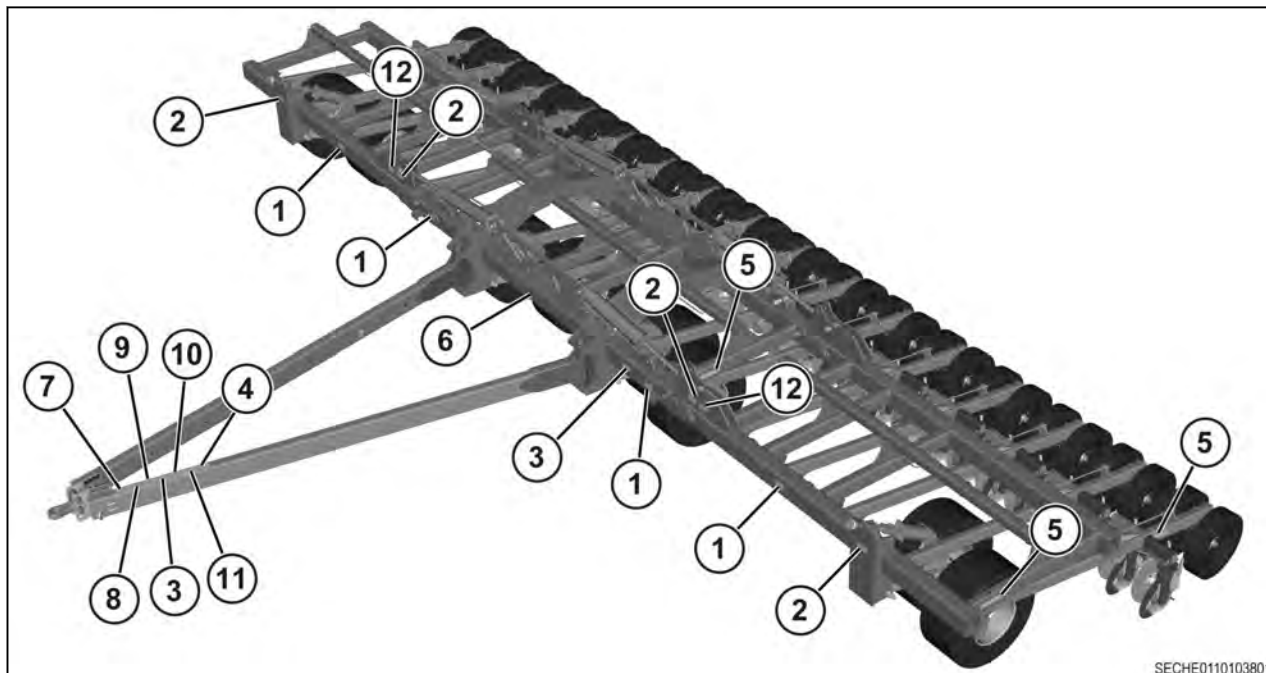

Fig. 34

## 1.9 Safety sign location

### Three-section frame safety signs

The following safety signs will be installed on the frame of the drill.



SECHE0110103801

Fig. 35

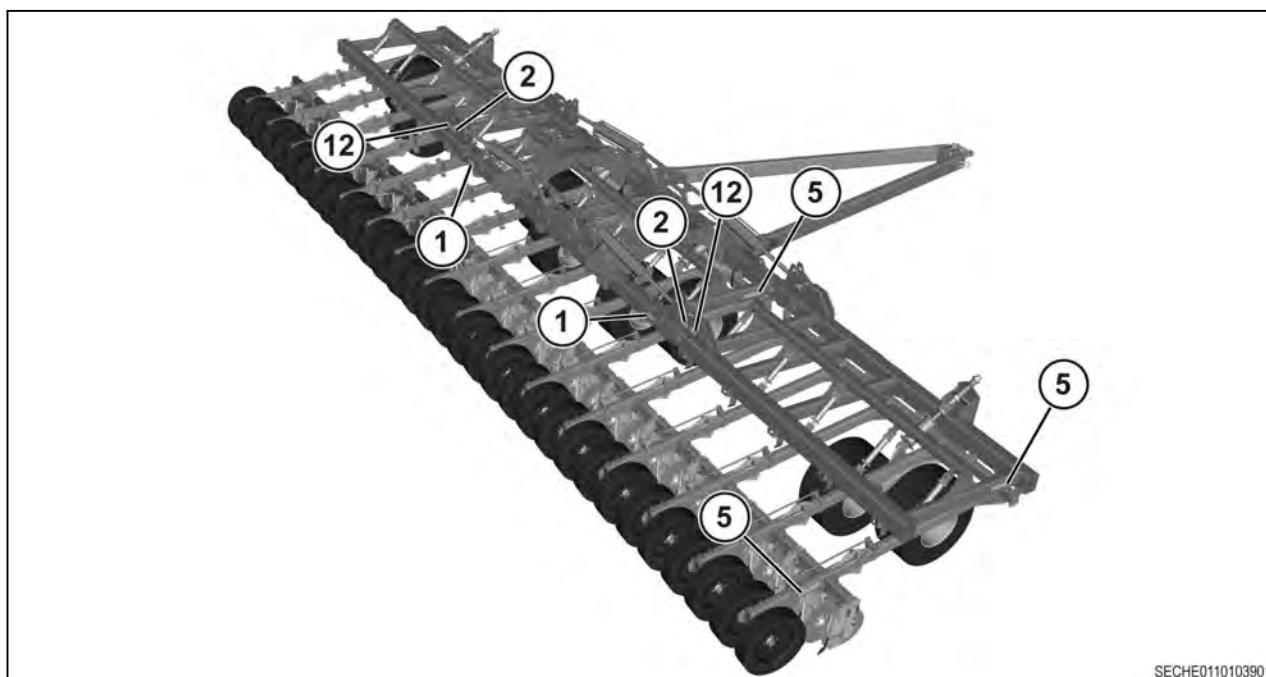

SECHE0110103901

Fig. 36

### Five-section frame safety signs

The following safety signs will be installed on the frame of the drill.

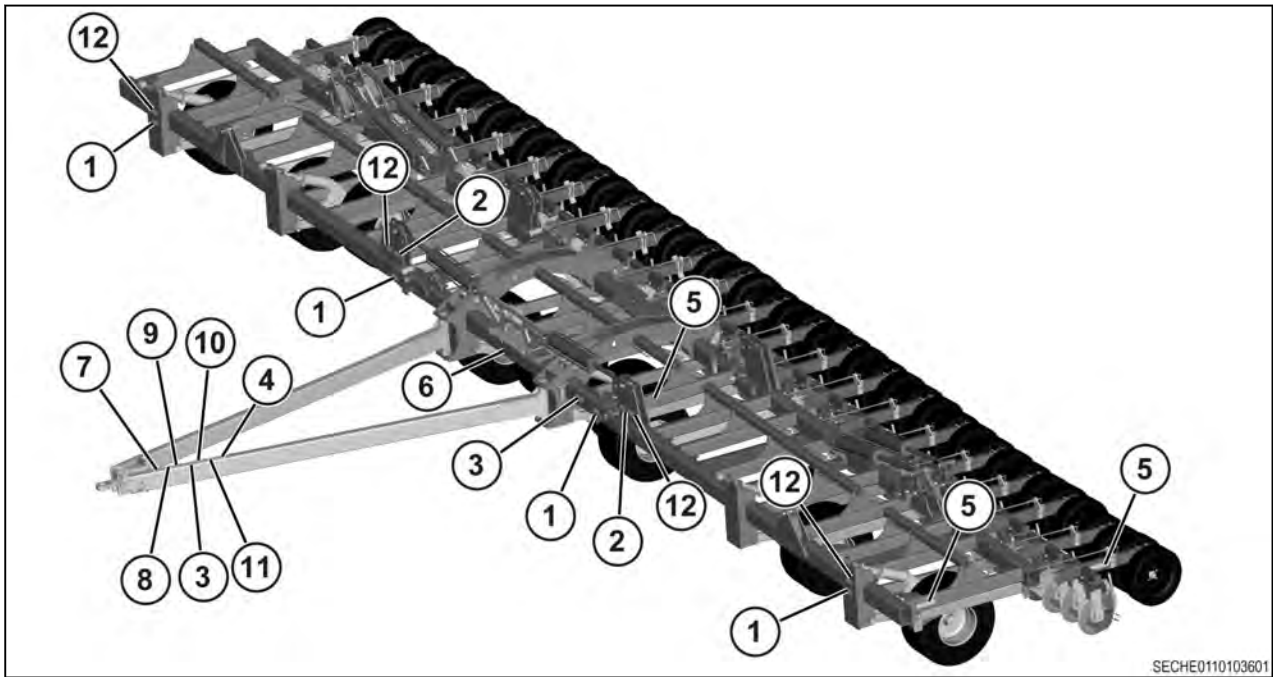

SECHE0110103601

Fig. 37

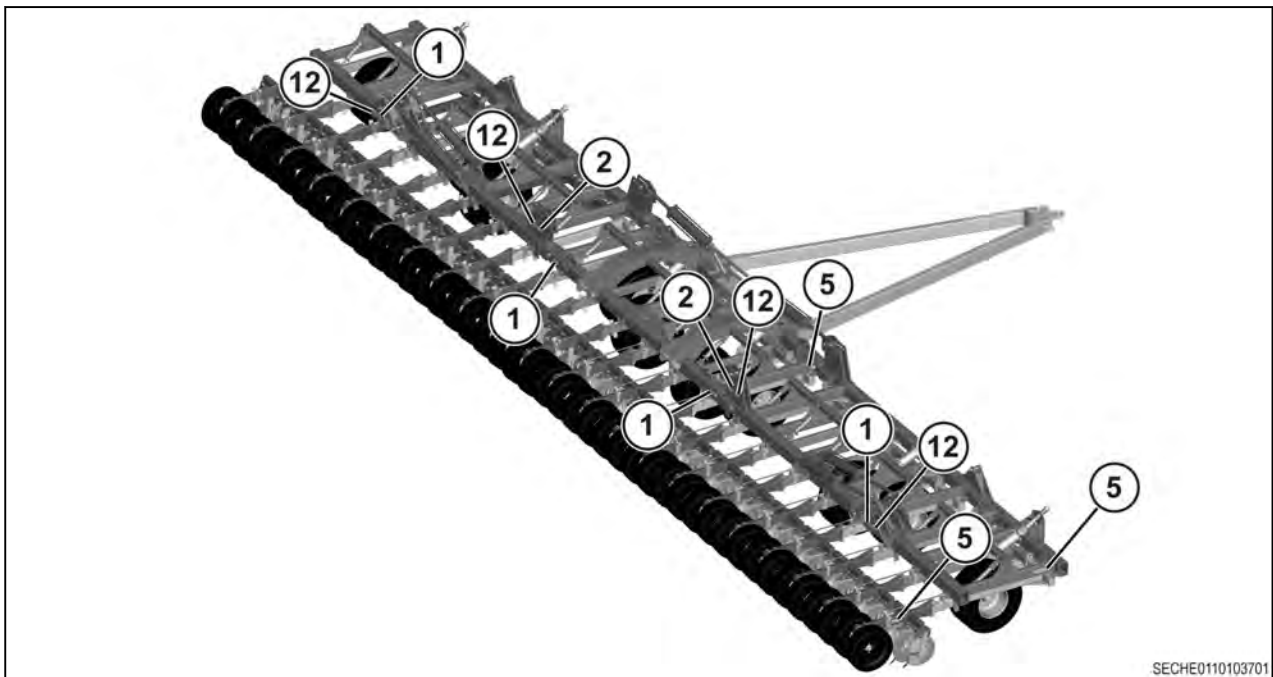

SECHE0110103701

Fig. 38

Item	Description	Qty.	
		Three-section	Five-section
1	Danger / Folding Wings	4	8
2	Warning / Lockout	6	4
3	Warning / Read Operator Manual	2	2
4	Warning / Chemical Hazard	1	1
5	Reflector / Yellow	6	6
6	Maximum Speed	1	1

Item	Description	Qty.	
		Three-section	Five-section
7	Caution / Safety Chains	1	1
8	Warning / Negative Tongue Weight	1	1
9	Warning / Remove Key	1	1
10	Danger / High Line	1	1
11	Warning / Hydraulic Fluid Pressure	1	1
12	Warning / Wing Locks	4	4

Most of the safety signs on this implement have two panels with few or no words. The hazard panel (A) depicts the hazard and the consequence of encountering the hazard. The avoidance panel (B) depicts the action required to avoid the hazard.

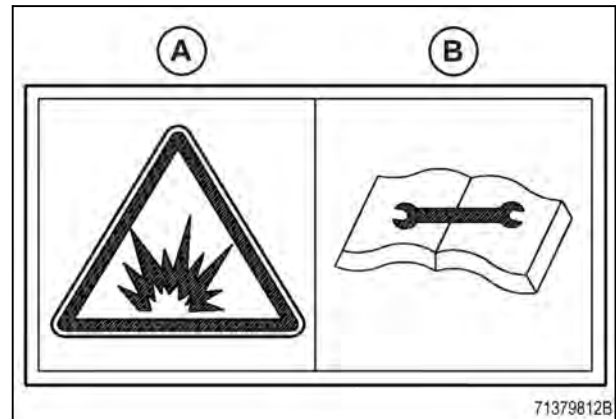

Fig. 39

Danger / Folding Wings (1)

**Hazard (A):** Crushing hazard from lowering or falling wing

**Avoidance (B):** Stay clear of this area while engine and machine are operating. For service work, install the wing lock pins before getting under wing.

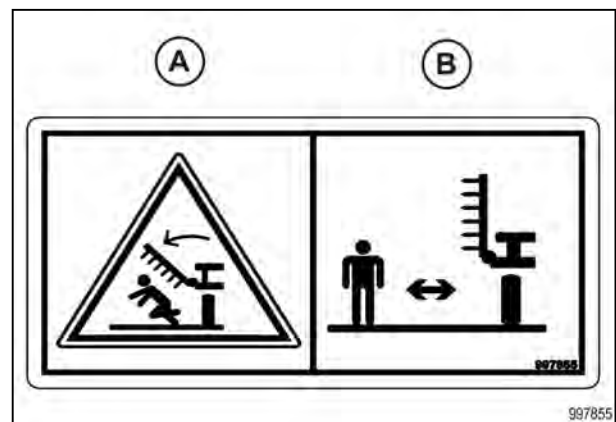

Fig. 40

Warning / Lockout (2)

**Hazard (A):** Crushing hazard

**Avoidance (B):** Stay clear of this area while engine and machine are operating. For service work, install the wing lock pins before getting under wing.

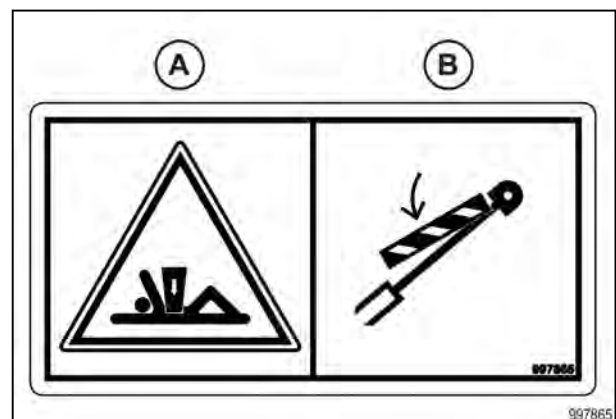

Fig. 41

Warning / Read Operator Manual (3)

**Hazard (A):** General safety alert

**Avoidance (B):** Read and understand the Operator Manual before operating the machine.

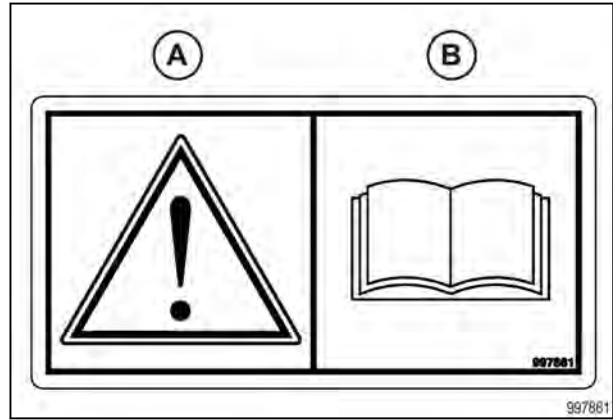

Fig. 42

Warning / Chemical Hazard (4)

**Hazard (A):** Dust/fumes inhalation hazard - risk of asphyxiation

**Avoidance (B):** Read the Operator Manual for safety information and operating instructions before operating the machine.

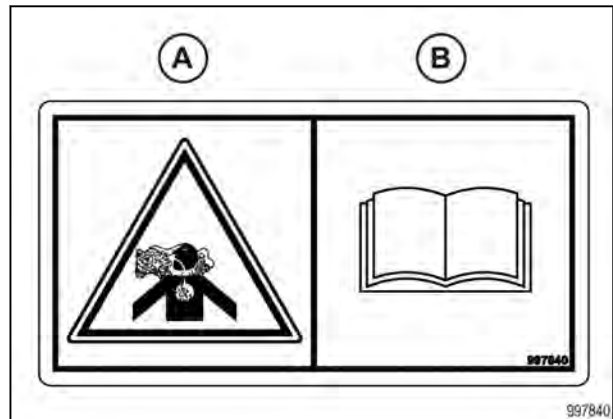

Fig. 43

Reflector / Yellow (5)

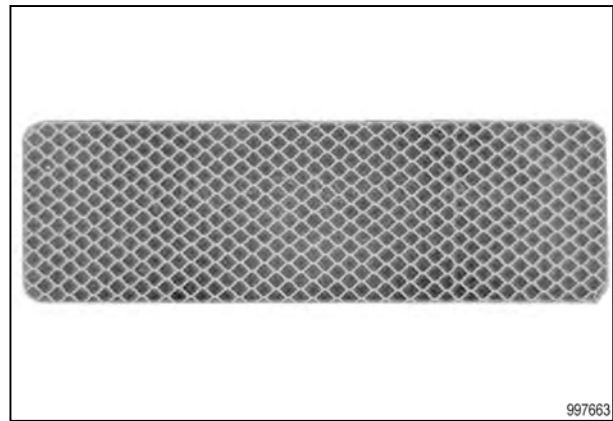

Fig. 44

## Maximum Speed (6)

The maximum speed safety sign displays the maximum speed the machine can be transported.

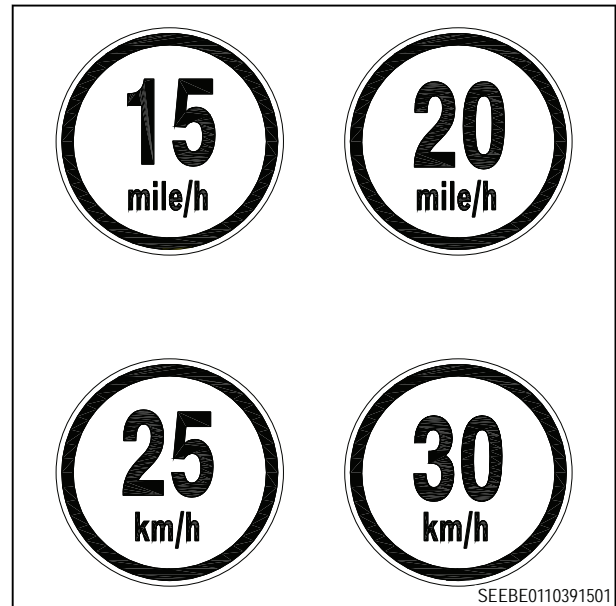

Fig. 45

## Caution / Safety Chains (7)

**Hazard (A):** Lose of machine control

**Avoidance (B):** Install the safety chains when attaching the implement to the tractor. Read the Operator Manual for safety information and operating instructions before operating the machine.

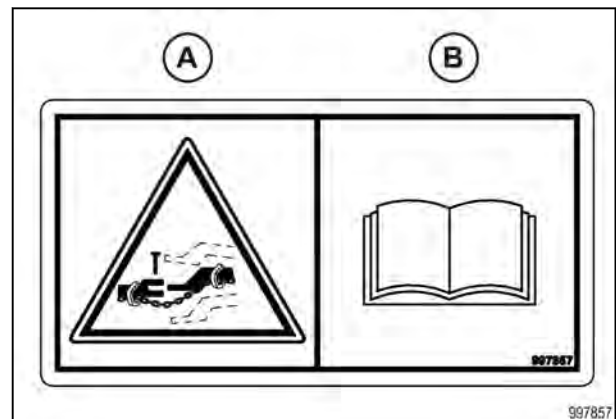

Fig. 46

## Warning / Negative Tongue Weight (8)

**Hazard (A):** Negative tongue weight will cause immediate elevation of the tongue.

**Avoidance (B):** Stay clear of the tongue when disconnecting the implement from the tractor. Read the Operator Manual for safety information and operating instructions before operating the machine.

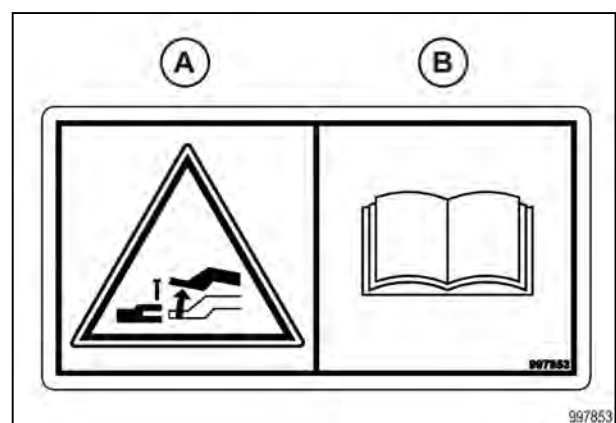

Fig. 47

Warning / Remove Key (9)

**Hazard (A):** General safety alert

**Avoidance (B):** Shut off engine and remove the key before performing maintenance or repair work.

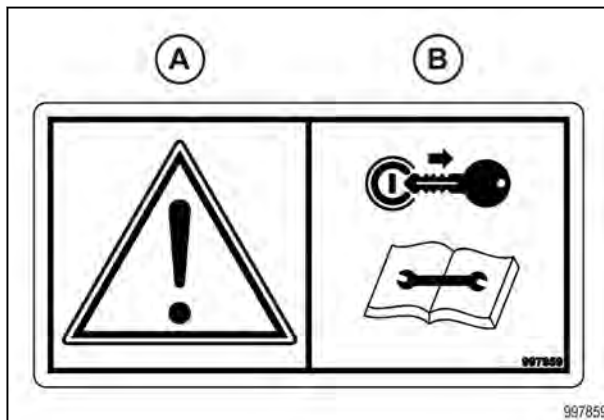

Fig. 48

Danger / Electrical Shock (10)

**Hazard (A):** Electrical shock hazard - risk of personal injury and component damage

**Avoidance (B):** Keep the machine clear of overhead electrical power lines.

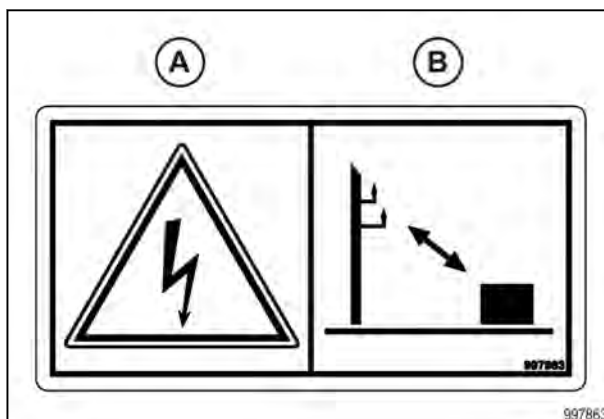

Fig. 49

Warning / Hydraulic Fluid Pressure (11)

**Hazard (A):** Injection hazard into skin - escaping fluid under high pressure

**Avoidance (B):** Shut off engine, remove key, and relieve pressure before performing maintenance or repair work. Refer to the Operator Manual for proper service procedures.

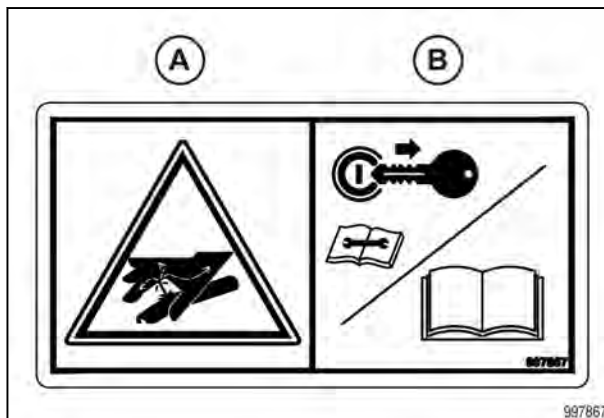

Fig. 50



Warning / Wing Locks (12)

**Hazard (A):** Crushing hazard from lowering or falling wing

**Avoidance (B):** Install the wing lock pins before transporting the implement.

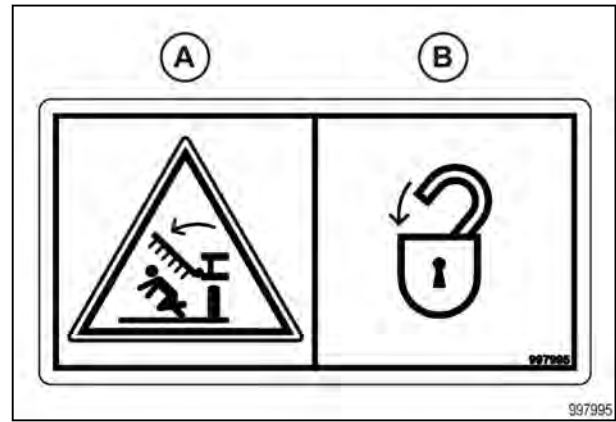

Fig. 51

**Floating rear hitch safety signs**

The following safety signs will be installed on the drills equipped with a floating rear hitch.

Item	Description	Qty.
1	Warning / Read Operator Manual	1
2	Warning / Chemical Hazard	1
3	Reflector / Yellow	2
4	Slow Moving Vehicle Emblem	1

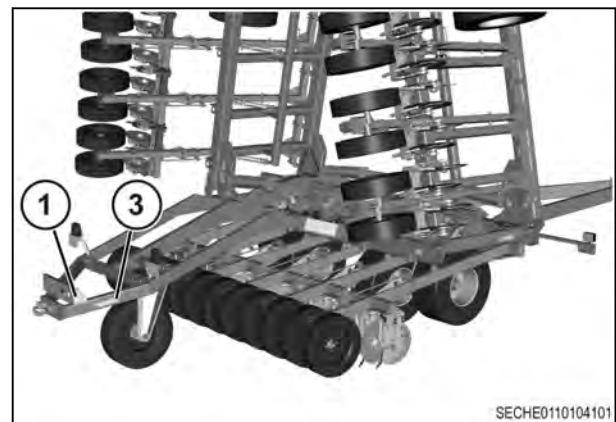

Fig. 52

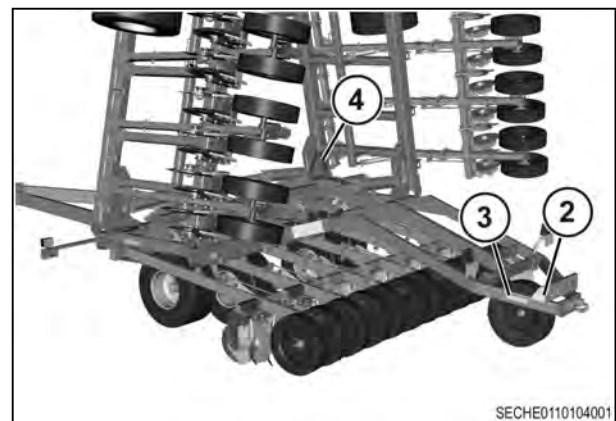

Fig. 53

Warning / Read Operator Manual (1)

**Hazard (A):** General safety alert

**Avoidance (B):** Read and understand the Operator Manual before operating the machine.

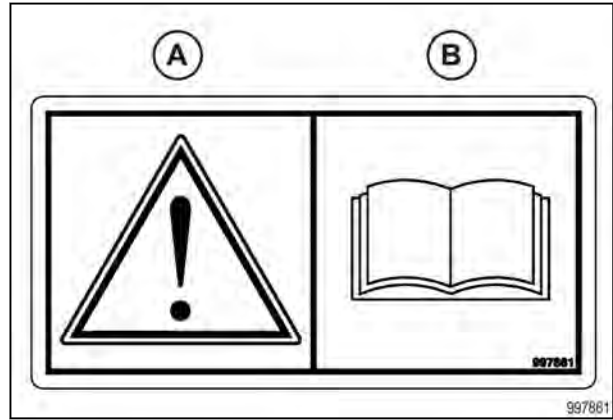

Fig. 54

Warning / Chemical Hazard (2)

**Hazard (A):** Dust/fumes inhalation hazard - risk of asphyxiation

**Avoidance (B):** Read the Operator Manual for safety information and operating instructions before operating the machine.

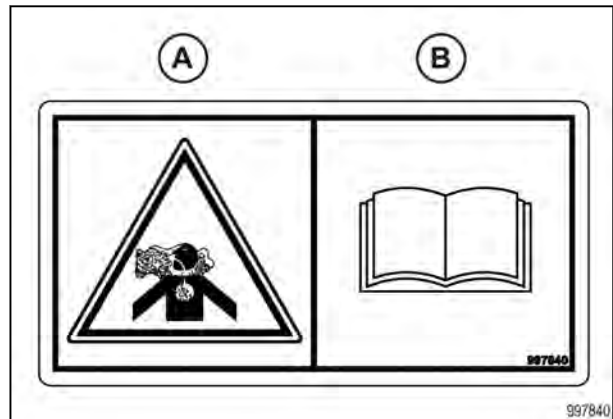

Fig. 55

Reflector / Yellow (3)

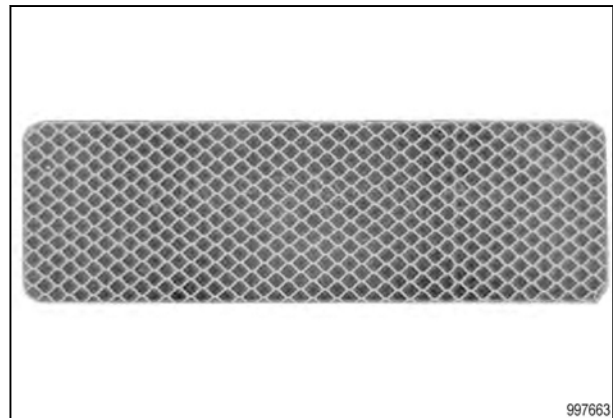

Fig. 56

## Slow Moving Vehicle Emblem (4)

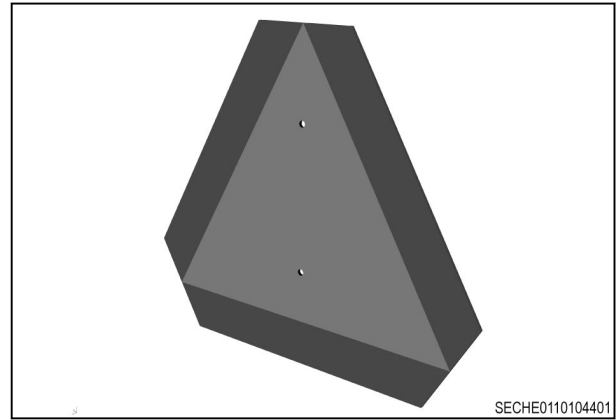

Fig. 57

**Hydraulic lift assist rear hitch safety signs**

The following safety signs will be installed on the drills equipped with a hydraulic lift assist rear hitch.

Item	Description	Qty.
1	Warning / Read Operator Manual	1
2	Warning / Chemical Hazard	1
3	Reflector / Yellow	2
4	Slow Moving Vehicle Emblem	1
5	Danger / Explosion	1

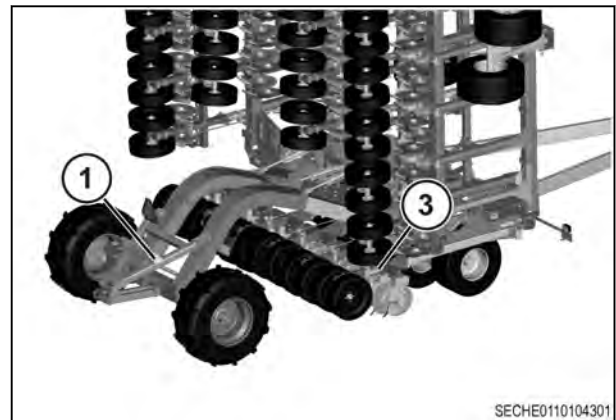

Fig. 58

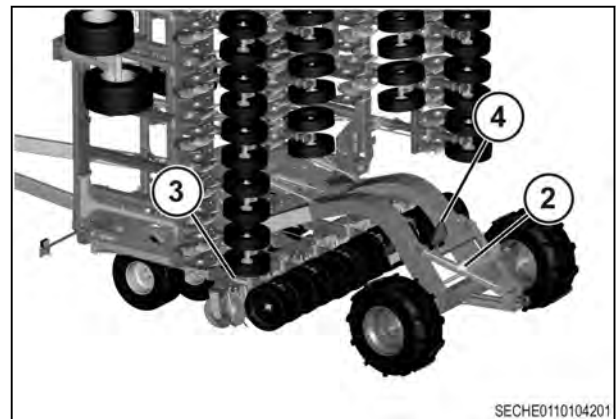

Fig. 59

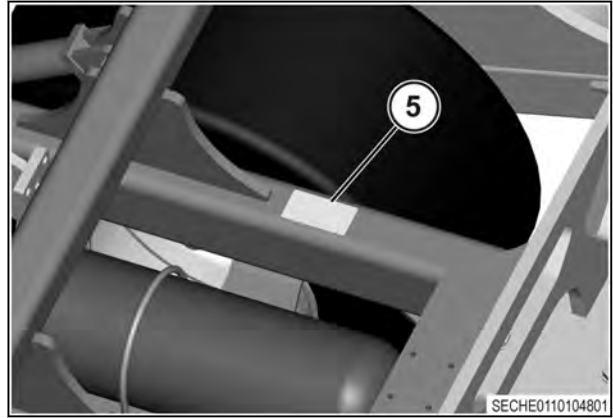

Fig. 60

Warning / Read Operator Manual (1)

**Hazard (A):** General safety alert

**Avoidance (B):** Read and understand the Operator Manual before operating the machine.

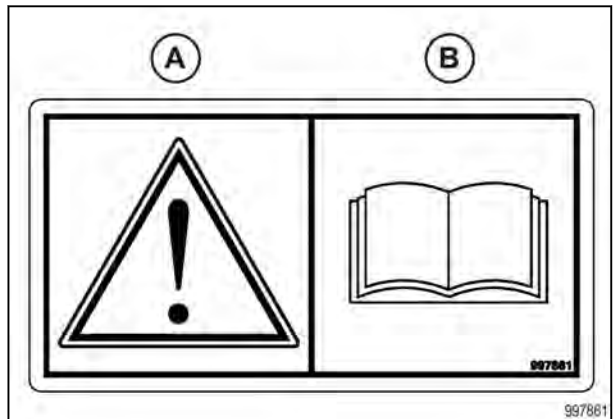

Fig. 61

Warning / Chemical Hazard (2)

**Hazard (A):** Dust/fumes inhalation hazard - risk of asphyxiation

**Avoidance (B):** Read the Operator Manual for safety information and operating instructions before operating the machine.

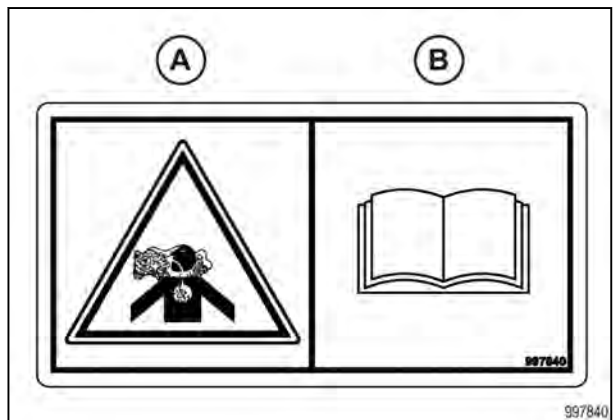
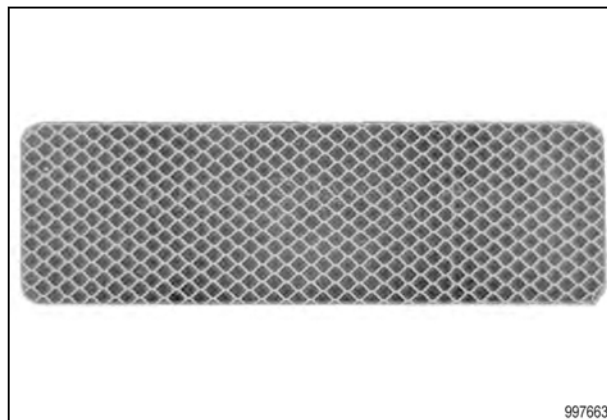

Fig. 62

Reflector / Yellow (3)



997663

Fig. 63

Slow Moving Vehicle Emblem (4)

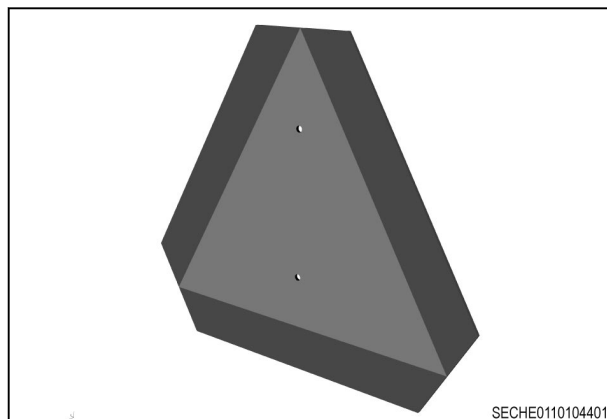

SECHE0110104401

Fig. 64

Danger / Explosion (5)

**Hazard (A):** Explosion hazard - accumulator contains gas and oil under pressure.

**Avoidance (B):** Shut off engine, remove key, and relieve pressure before performing maintenance or repair work.

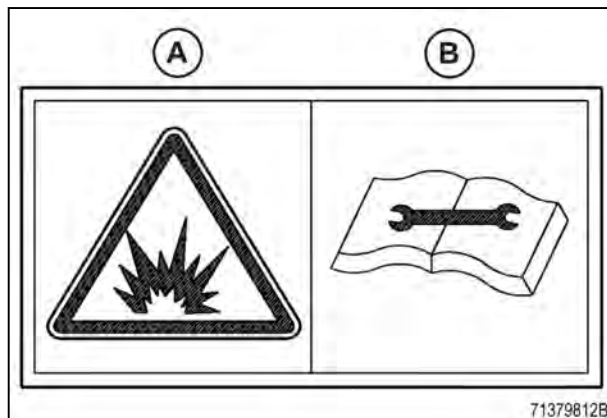

71379812B

Fig. 65



---

## 2. Introduction

<b>2.1 Introduction</b> .....	41
2.1.1 Intended use .....	41
2.1.1.1 Proper disposal of waste .....	41
<b>2.2 Machine identification</b> .....	42
2.2.1 Serial number plate .....	42
2.2.2 Serial number description .....	42
<b>2.3 Single disc drill</b> .....	44
<b>2.4 Major components</b> .....	45
<b>2.5 Operator manual storage</b> .....	46





## 2.1 Introduction



**CAUTION:**

**In some of the illustrations used in this Operator Manual, panels or guards may have been removed for clarity. Never operate the tractor with these panels and guards removed. If the removal of a shield is necessary to make a repair, it must be replaced before operation.**



**CAUTION:**

**Read this book in its entirety prior to operating machine. Use only genuine replacement parts for repairs and/or replacement.**

This manual gives the operator the proper instructions needed for operation and maintenance. Read, understand, and follow these instructions for best machine performance and life. With proper maintenance and operation procedures, the machine will have better over all performance. Use normally available tools for maintenance on this machine.

All operators must read and understand this manual before operating this machine. Where possible, operators who have not operated the machine must receive instruction from an operator who has operated this machine. Your dealer can give instruction in machine operation. Keep this manual with the machine for future reference. If the original manual is damaged, order a replacement from your dealer.

See your dealer in for any service problems and adjustments. The dealer is equipped for all service work and to help with specific applications of the tractor in local conditions.

Left-hand and right-hand are determined by facing the direction the machine will travel when in use.

---

### 2.1.1 Intended use

---

This machine is designed solely for use in customary agricultural operations.

Do not use this machine for any application or purpose other than those described in this manual. The manufacturer accepts no liability for damage or injury resulting from misuse of this machine.

Compliance with the conditions of operation, service and repair as specified by the manufacturer constitute essential elements for the intended use of this machine.

This machine should be operated, serviced and repaired only by qualified persons familiar with its characteristics and familiar with the relevant safety rules and procedures.

All generally recognized safety regulations and road traffic regulations must be obeyed at all times.

Any unauthorized modifications performed on this machine will relieve the manufacturer of all liability for any resulting damage or injury.

#### 2.1.1.1 Proper disposal of waste

Improper disposal of waste can pollute the environment and ecology. A few examples of potentially harmful equipment waste can include, but not limited to, items such as oil, fuel, coolant, brake fluid, filters, battery chemicals, tires, etc.

Use leak proof containers when draining fluids. Do not use food or beverage containers to collect waste fluids, as food or beverage container(s) may mislead someone into drinking from them.

Do not pour or spill waste onto the ground, down a drain, or into any water source.

Air conditioning refrigerants escaping into the air can damage the Earth's atmosphere. Government regulations may require a certified air conditioning service center to recover and recycle used air conditioning refrigerants.

Inquire with local environmental or recycling center on the proper way to recycle or dispose waste.

## 2.2 Machine identification

Each machine is identified by a model and a serial number.

Record these numbers in the spaces given.

Give the model number and serial number to your dealer when parts or service are required.

Machine model number: \_\_\_\_\_

Machine serial number: \_\_\_\_\_

Date of delivery: \_\_\_\_\_

Dealer name: \_\_\_\_\_

Dealer address: \_\_\_\_\_

\_\_\_\_\_

Dealer telephone number: \_\_\_\_\_

Dealer e-mail address: \_\_\_\_\_

Dealer fax number: \_\_\_\_\_

### 2.2.1 Serial number plate

The serial number plate (1) is located on the front of the main frame tube.

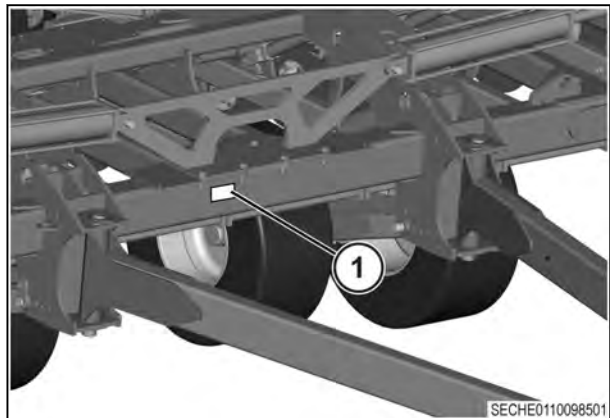

Fig. 1

### 2.2.2 Serial number description

Description of the serial number for model year 2010 and up.

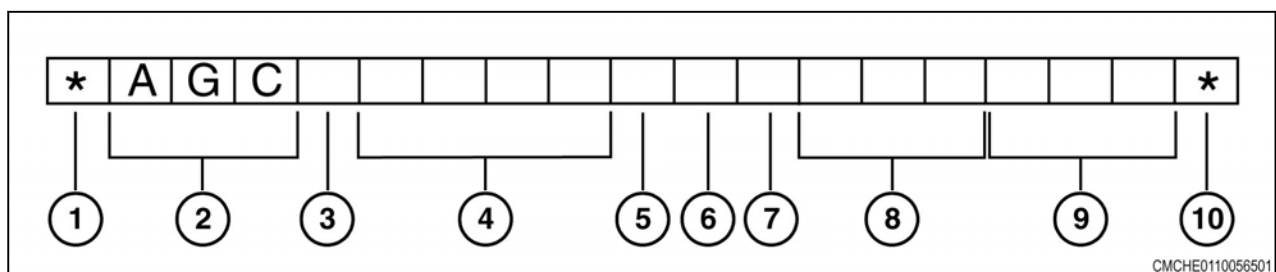

Fig. 2

- |                                     |   |
|-------------------------------------|---|
| (1) Beginning symbol                | (5) Check letter (0 or used if model identifier is five digits) |
| (2) World manufacturer code         | (6) Model year code (A=2010, B=2011, C=2012, and on)            |
| (3) Brand code                      |   |
| (4) Model identifier (model number) |   |

(7) Plant code  
(8) Family code

(9) Unit number for the year  
(10) Ending symbol

## 2.3 Single disc drill

The single disc drill is designed to seed in a range of soil conditions from no till with heavy residue to conventional till. The single disc drill can seed in these conditions without adjusting the openers. An air distribution system is used to distribute the seed to each of the openers from an air cart towed behind the drill. The drill is monitored using a display in the cab of the tractor.

The single disc drill is available in two different frame configurations. Each frame configuration is available in two widths.

### Three-section single disc drill

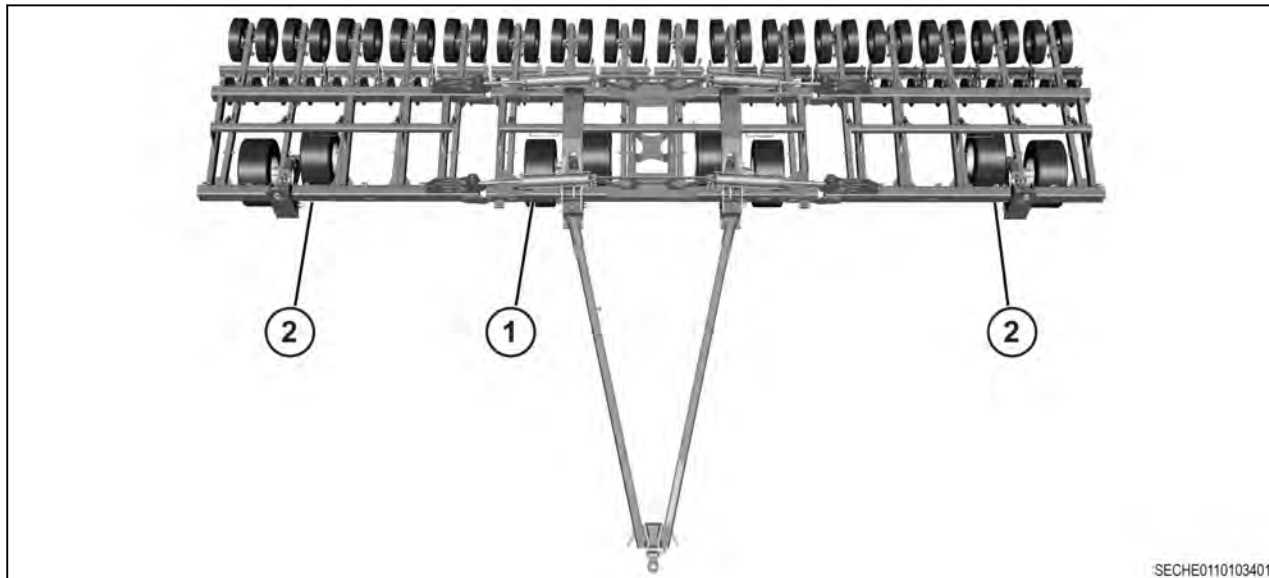

Fig. 3

The three-section single disc drill has a center frame (1) with two folding wings (2). The three-section drill is available in 9.14 m (30 ft) and 12.19 m (40 ft) widths.

### Five-section single disc drill

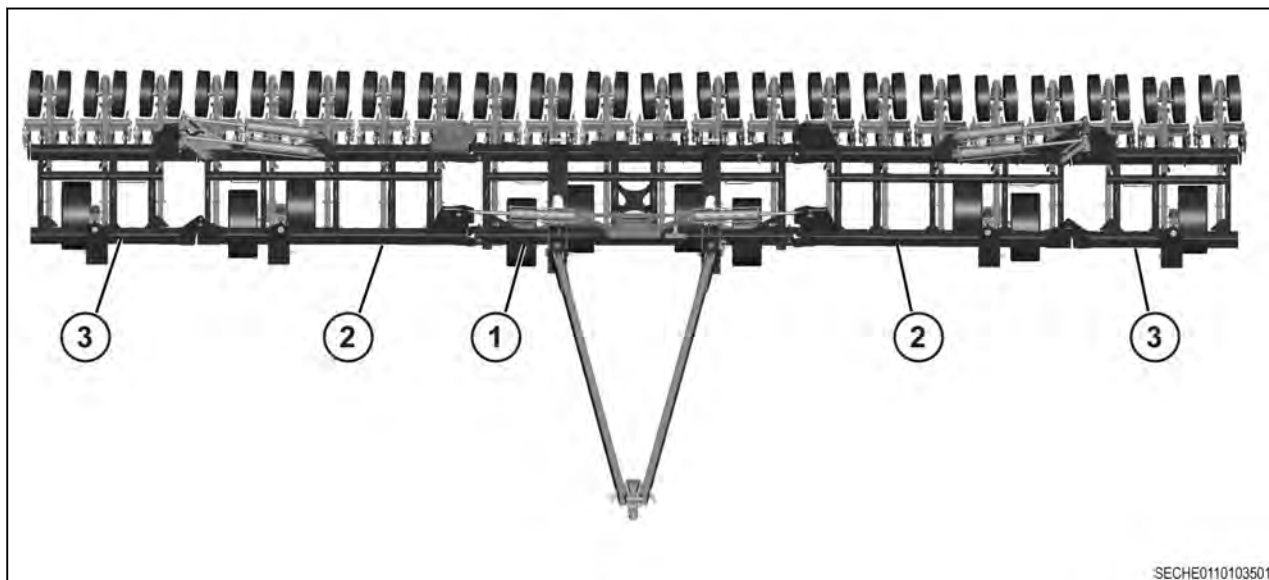

Fig. 4

The five-section single disc drill has a center frame (1), two folding wings (2), and a folding extension (3) on each folding wing. The five-section drill is available in 15.24 m (50 ft) and 18.28 m (60 ft) widths.

## 2.4 Major components

The following are the major components installed on the implement.

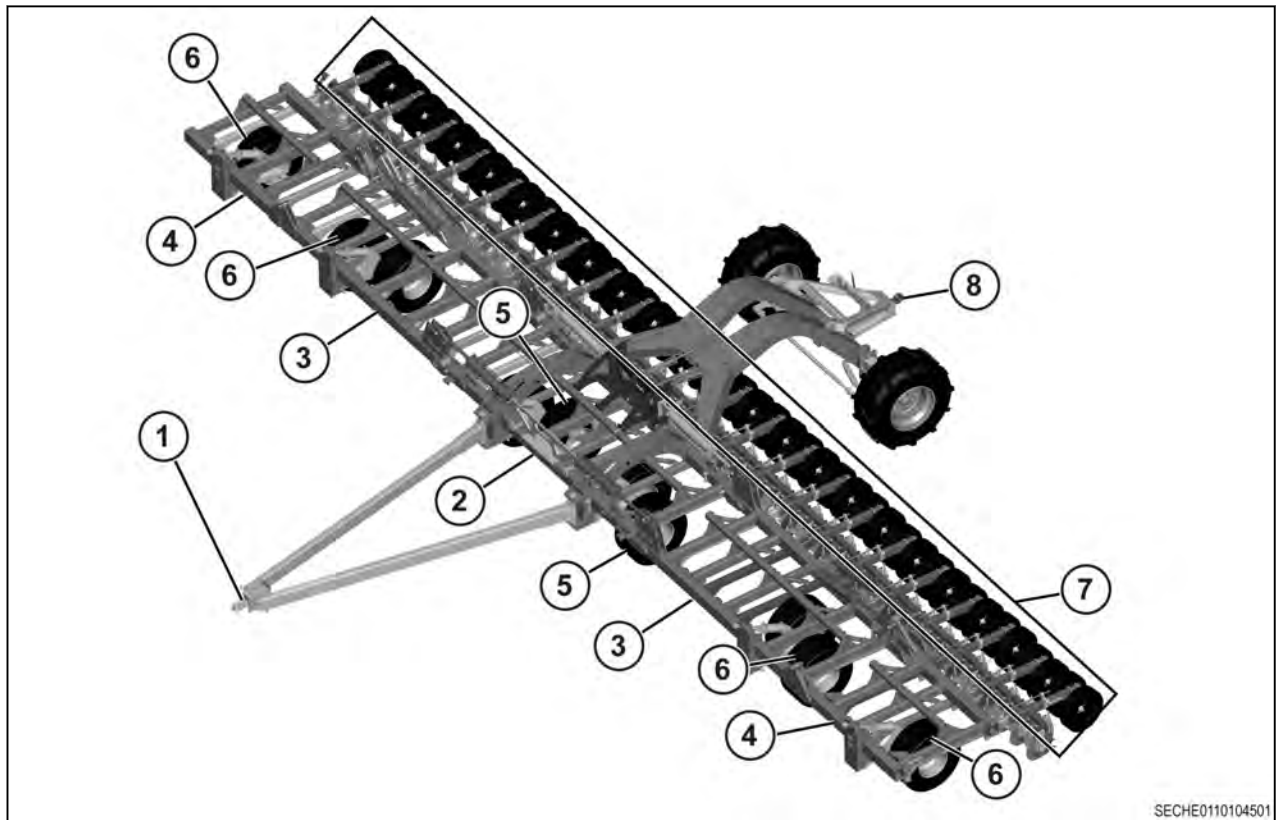

Fig. 5

- |                          |                               |
|--------------------------|-------------------------------|
| (1) Front hitch          | (5) Main frame support wheels |
| (2) Main frame           | (6) Wing frame support wheels |
| (3) Wing frame           | (7) Toolbars                  |
| (4) Wing frame extension | (8) Rear hitch                |

- |                   |
|-------------------|
| (1) Opening discs |
| (2) Packer tires  |

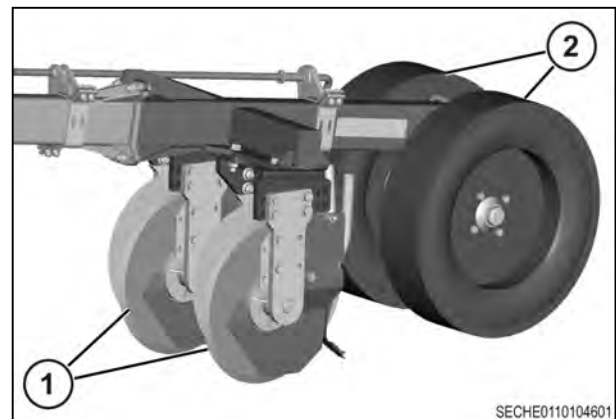

Fig. 6

## 2.5 Operator manual storage

The Operator Manual is stored in the container (1) located on the front hitch of the machine.

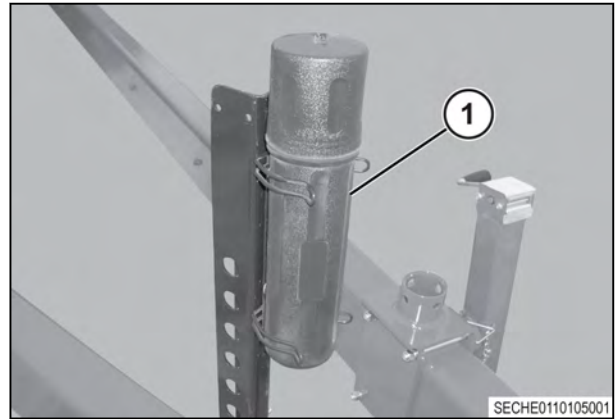

Fig. 7

## 3. Operation

<b>3.1 ISOBUS Harness Connector</b> .....	49
<b>3.2 Connecting the drill to the tractor</b> .....	50
<b>3.3 Disconnecting the drill from the tractor</b> .....	52
<b>3.4 Preparing the drill for transport</b> .....	55
<b>3.5 Preparing the drill for seeding</b> .....	57
<b>3.6 Packing tires</b> .....	59
3.6.1 Packing tire air pressure .....	59
<b>3.7 Seed depth</b> .....	60
3.7.1 Checking the seed depth .....	60
3.7.2 Seed depth collar sequences .....	61
3.7.3 Initial seed depth collar sequences .....	62
3.7.4 Adjusting seed depth .....	62
<b>3.8 Toolbar down pressure</b> .....	63
3.8.1 Down pressure control box .....	63
3.8.2 Setting the toolbar down pressure .....	64
<b>3.9 Turning at the edge of a field</b> .....	65
<b>3.10 Hydraulic lift assist</b> .....	66
3.10.1 Hydraulic lift assist hydraulic caster lock .....	66
3.10.2 Hydraulic lift assist pressure gauge .....	66
<b>3.11 NH3 system</b> .....	68
3.11.1 NH3 menu buttons .....	68
3.11.2 NH3 system work screen .....	69
3.11.3 Product on/off buttons .....	70
3.11.4 Product on/off indicator .....	70
3.11.5 Target application rate .....	70
3.11.6 Actual application rate .....	71
3.11.7 Ground speed .....	71
3.11.8 Seeding indicator .....	72
3.11.9 Toolbar position .....	72
3.11.10 Tank fill percentage .....	72
3.11.11 Tank size .....	73
3.11.12 Product density .....	73
3.11.13 Product weight .....	73
3.11.14 Applied area counter .....	74
3.11.15 Applied weight counter .....	74
3.11.16 Liquid calibration number .....	74
3.11.17 Calculating the liquid calibration number .....	74
3.11.18 Verifying the liquid calibration number .....	75
3.11.19 Purging air from the system .....	75
3.11.20 NH3 system settings screen .....	76
3.11.21 Machine width .....	77
3.11.22 Target flow of the flow-meter .....	77
3.11.23 Actual flow of the flow-meter .....	77
3.11.24 Control valve gain .....	78
3.11.25 Valve polarity .....	78
3.11.26 Number of valves .....	78





### 3.1 ISOBUS Harness Connector

The machine has three connectors used to connect to the ISOBUS harness.

#### Front ISOBUS Connector

The front ISOBUS connector is located on the front hitch of the machine and is used to connect the machine ISOBUS to the tractor. The front ISOBUS connector is a standard nine pin connector.

#### Rear ISOBUS Connector

The rear ISOBUS connector (1) is located in the rear connection bulkhead and is used to connect the machine ISOBUS to a pull behind implement. The rear ISOBUS connector is a standard nine pin connector.

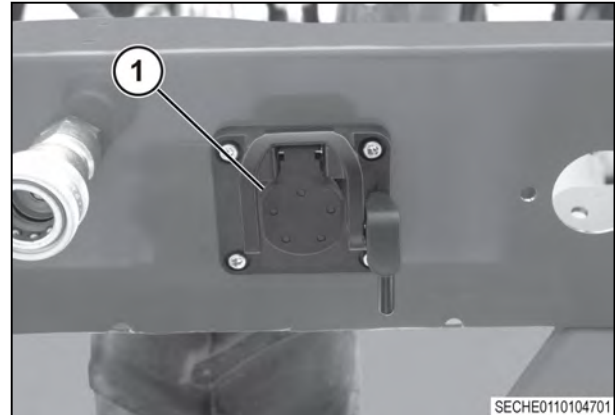

Fig. 1

#### ECU ISOBUS Connector

The ECU ISOBUS connector is located on the left-hand side of the middle main frame cross member. The ECU ISOBUS connector is used to connect the NH3 ECU or any other installed electronic controller to the machine ISOBUS.

## 3.2 Connecting the drill to the tractor

### Procedure

1. Make sure there are no people, pets, or obstructions between the tractor and the drill.

2. Use the hitch jack (1) on the front hitch of the drill to adjust the height of the hitch. Adjust the height of the hitch on the drill until the hitch on the drill is at the same height as the hitch on the tractor.

3. Slowly reverse the tractor toward the hitch of the drill. Align the hitch on the tractor with the hitch on the drill when backing.

4. Stop the tractor when the hole of the tractor hitch aligns with the hole in the drill hitch.

5. Stop the engine, set the park brake, and take the ignition key with you.

6. Install the hitch pin (1) through the holes in the tractor draw bar (2) and drill hitch (3). Install the keeper pin (4) in the hitch pin.

7. Connect the safety chains from the front hitch of the drill to the tractor.

8. Retract the hitch jack (1).

9. Clean the ends of the hydraulic connections on the drill and the tractor.

10. Make the following connections between the tractor and the drill.

- Lift cylinder hydraulic hoses
- Wing cylinder hydraulic hoses
- Toolbar down pressure hydraulic hoses
- Air car hydraulic hoses
- ISO harness to the tractor
- Down pressure harness from the down pressure control box
- Safety light harness

**IMPORTANT:** Connect the toolbar down pressure hydraulic hoses and wing cylinder hydraulic hoses directly to the tractor hydraulics. Aftermarket or added hydraulic connections do not supply the needed hydraulic flow to operate the drill correctly.

11. Start the tractor and use the tractor hydraulics to lift the frame of the drill to the highest position.

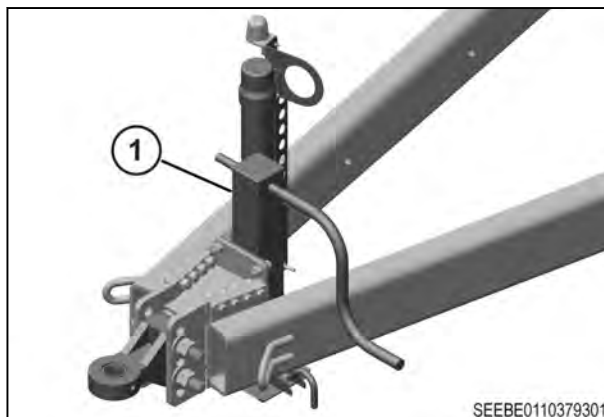

Fig. 2

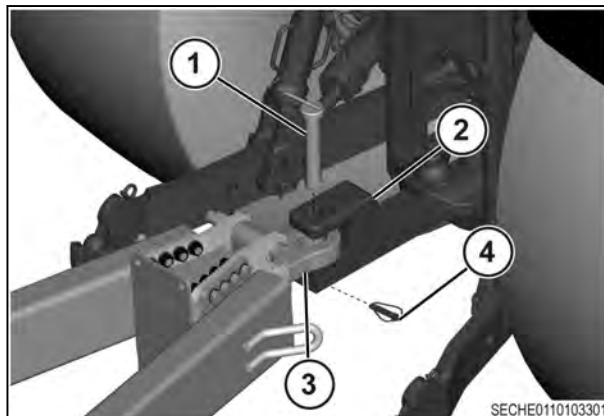

Fig. 3

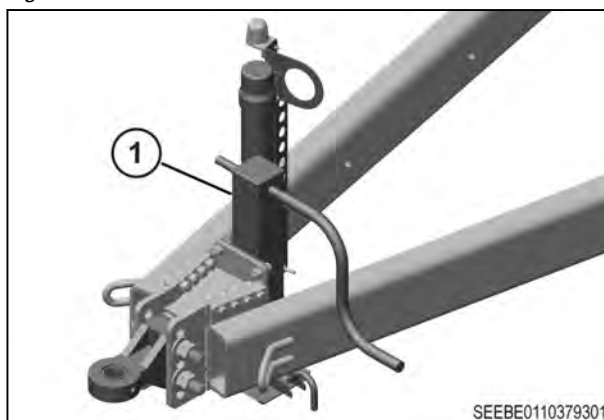

Fig. 4

12. If the wing frames were down during storage, make sure the wing cylinders are connected to the wing frames.
13. Use the tractor hydraulics to fully lift the wing frames of the drill.
14. Stop the engine, set the park brake, and take the ignition key with you.
15. Remove the wheel chocks (1) or blocks from in front of and behind the frame support tires (2).



Fig. 5

16. Remove all the seed depth collars (1) from each of the frame height cylinders (2). Install the removed seed depth collars on the collar storage brackets on the frame of the drill.
17. Make sure all people, pets, and obstructions are clear before moving the tractor and drill.

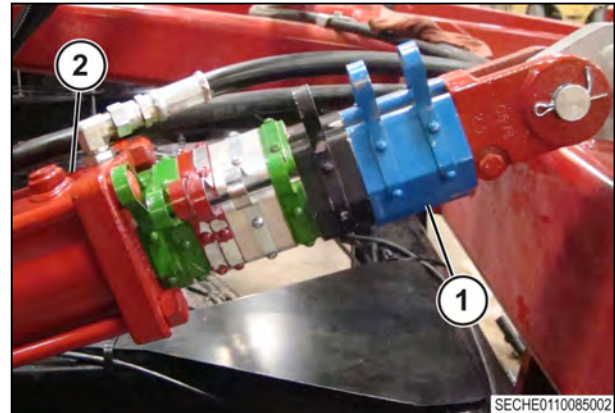

Fig. 6

### 3.3 Disconnecting the drill from the tractor

**NOTE:** Lower the wings for storage when possible.

#### Procedure

1. Park the tractor and drill on a solid level surface.
2. Stop the engine, set the park brake, and take the ignition key with you.
3. Use the tractor hydraulics to lower the wings to the ground if possible.
4. Use the tractor hydraulics to fully lift the toolbars.
5. Stop the engine, set the tractor park brake, and take the ignition key with you.
6. When disconnecting the drill with the wing frames lifted, install the wing lock pins (1) in the wing lock brackets (2).

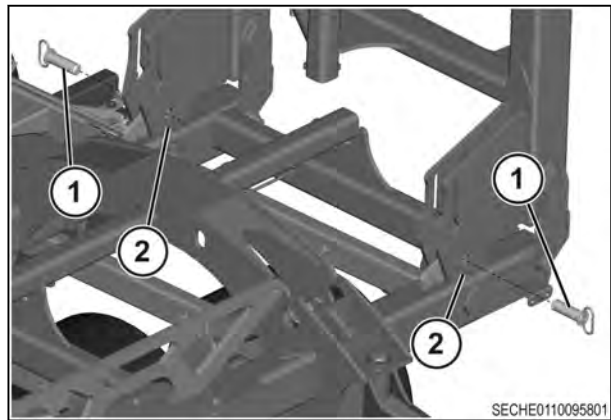

Fig. 7

7. Use the toolbar locks (1) to lock the toolbars in the raised position.

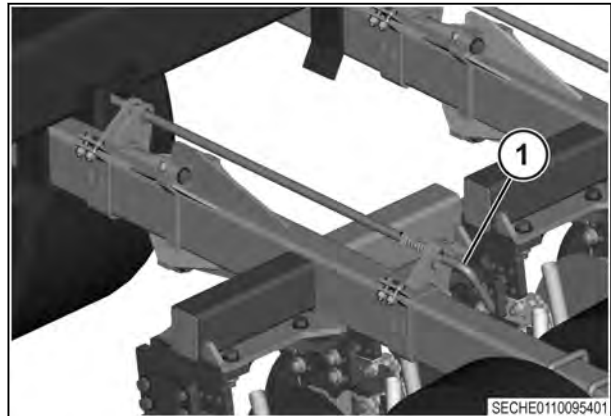

Fig. 8

8. Install wheel chocks (1) or blocks in front of and behind each of the frame support tires (2).



Fig. 9

9. Remove all the seed depth collars (1) from the frame height cylinders (2) and place them on the depth collar storage bracket.
10. Start the tractor. Lower the frame of the drill until the weight of the drill is off of the hitch of the tractor.
11. Stop the engine, set the tractor park brake, and take the ignition key with you.
12. Install the correct seed depth collars on the frame height cylinders to take up the remaining stroke of each frame height cylinder.
13. Start the tractor. Continue to lower the frame of the drill until the seed depth collars support the weight of the frame.
14. Use the hitch jack (1) to support the front hitch of the drill.
15. Disconnect the following connections from the tractor.
  - Lift cylinder hydraulic hoses
  - Wing cylinder hydraulic hoses
  - Down pressure hydraulic hoses
  - Air cart hydraulic hoses
  - ISO harness to the tractor
  - Down pressure harness from the down pressure control box
  - Light harness
16. Install each of the hydraulic hose connections (1) in the hose support bracket (2).

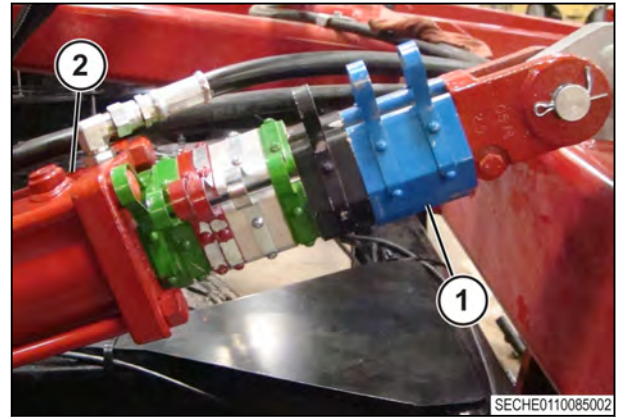

Fig. 10

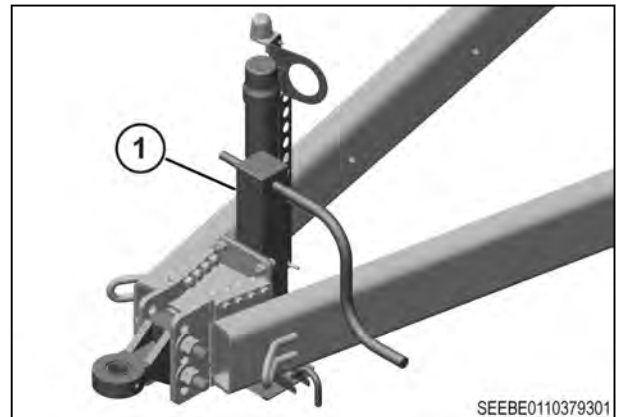

Fig. 11

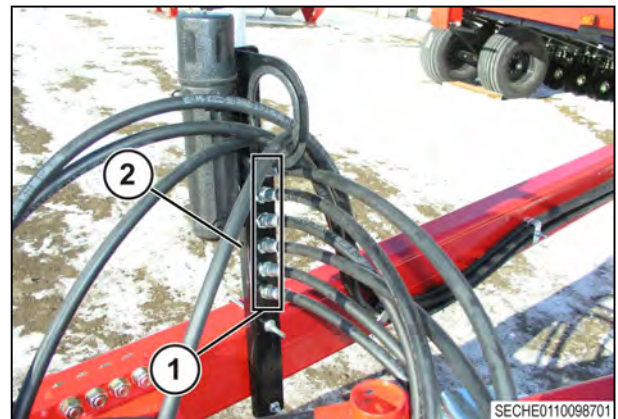

Fig. 12

17. Install the connector (1) for the light harness in the plug holder (2) on the hose support bracket (3).
18. Clean the hydraulic connections between the drill and the tractor of any dirt or hydraulic fluid.
19. Remove the transport safety chains from the tractor.

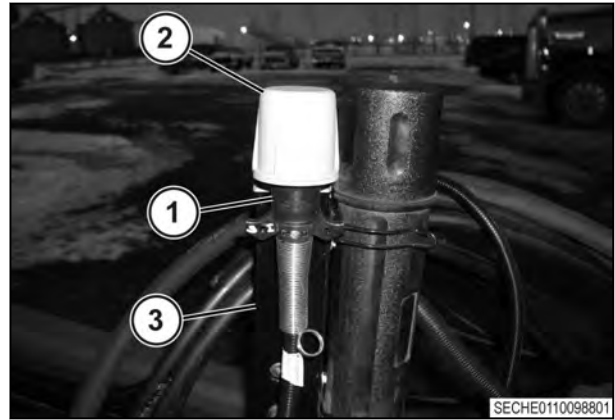

Fig. 13

20. Remove the keeper pin (1) from the hitch pin (2). Remove the hitch pin from the hitch (3) and draw bar (4).

**IMPORTANT:** *Make sure there are no connections between the tractor and the drill.*

21. Make sure all people and pets are clear of the tractor and drill.
22. Slowly pull the tractor away from the drill.

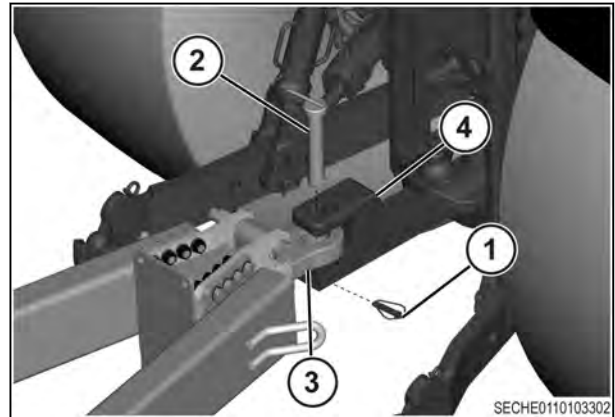

Fig. 14

### 3.4 Preparing the drill for transport

#### Before starting the procedure

Stop the tractor before preparing the drill for transport. Remove any remaining seed from the hopper if pulling the air cart with the drill during transport.

#### Procedure

1. Use the tractor hydraulics to lift the frame of the drill to the highest position.
2. Use the tractor hydraulics to fully lift the toolbars of the drill.
3. Use the tractor hydraulics to fully lift the wings of the drill.
4. Stop the engine, apply the tractor park brake, and take the ignition key with you.
5. Move the handle of the toolbar lock-out (1) to the closed position.

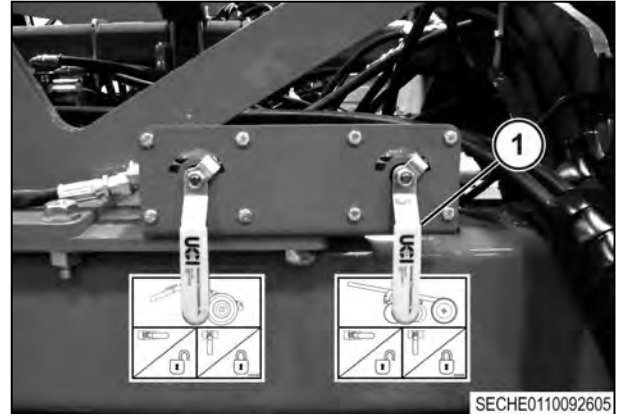

Fig. 15

6. On drills equipped with a hydraulic lift assist hitch, check the position of the gauge needle on the hydraulic lift assist pressure gauge.
  - If the gauge needle is within the green zone, move the handle of the hydraulic lift assist lock-out to the closed position.
  - If the gauge needle is not within the green zone, the wings must be dropped and raised again. Start the tractor, drop the wings of the drill to the ground, and raise the wings again. Check the position of the gauge needle on the hydraulic lift assist pressure gauge.



Fig. 16

**IMPORTANT:** *The gauge needle must be in the green zone before transporting the drill.*



7. Lock the wings in the raised position by installing the wing lock pins (1) in the wing lock brackets (2).

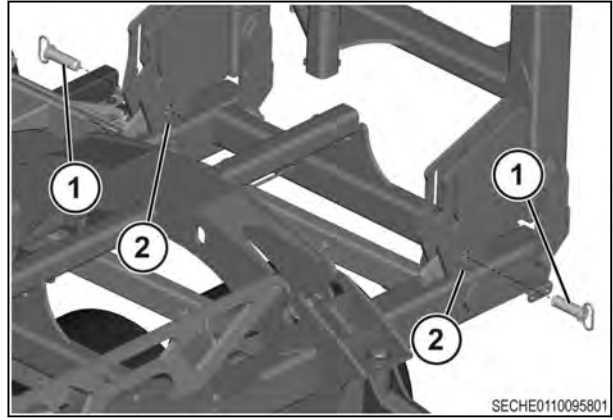

Fig. 17

8. Lock the toolbars in the raised position by moving the toolbar locks to the locked position.

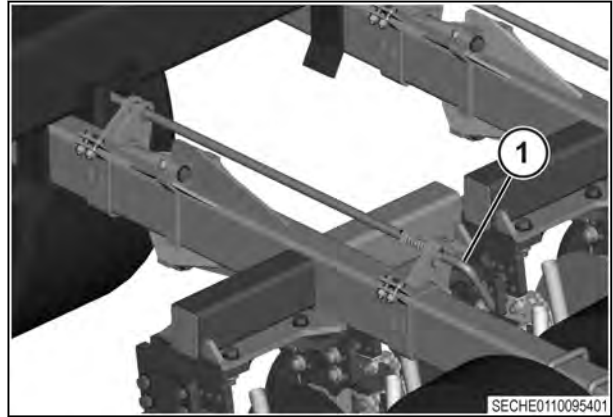

Fig. 18

9. On drills equipped with the hydraulic lift assist rear hitch, move the caster lock pins (1) to the caster lock brackets (2).

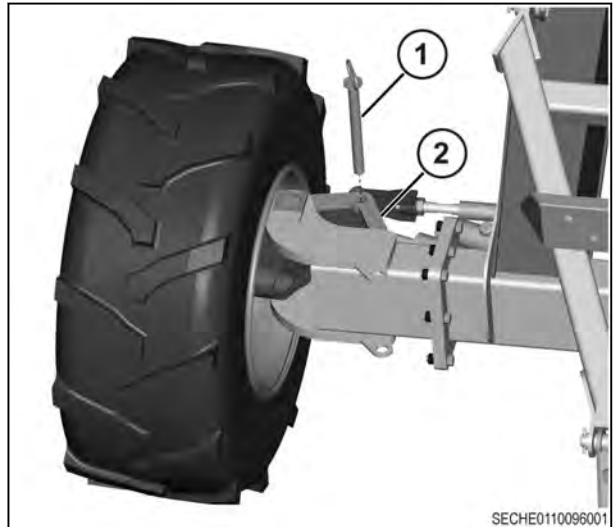

Fig. 19



### 3.5 Preparing the drill for seeding

#### Before starting the procedure

The drill must be connected to a tractor that is the correct size to operate the drill. Make sure there is enough area around the drill to completely lower the wings.

#### Procedure

1. Stop the tractor. Stop the engine, apply the tractor park brake, and take the ignition key with you.
  2. Make sure the area below the drill is clear of people, pets, and obstructions.
  3. Move the toolbar lock-out handle (1) to the open position. On drills equipped with a hydraulic lift assist hitch, move the hydraulic lift assist lock-out handle (2) to the open position.
  4. Start the tractor.
  5. Use the tractor hydraulics to remove any load from the toolbar locks by fully lift the toolbars.
  6. Use the tractor hydraulics to remove any load from the wing lock pins by fully lift the wings.
  7. Stop the engine and take the ignition key with you.
  8. Move all the toolbar locks (1) to the unlocked position.
9. Remove the wing lock pins (1) from the wing lock brackets (2). Install the wing lock pins in the storage brackets on the frame.
  10. Start the tractor.
  11. Use the tractor hydraulics to lower the wings to the operating position.

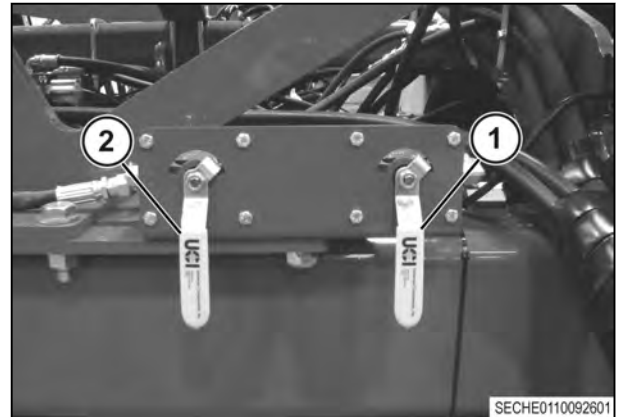

Fig. 20

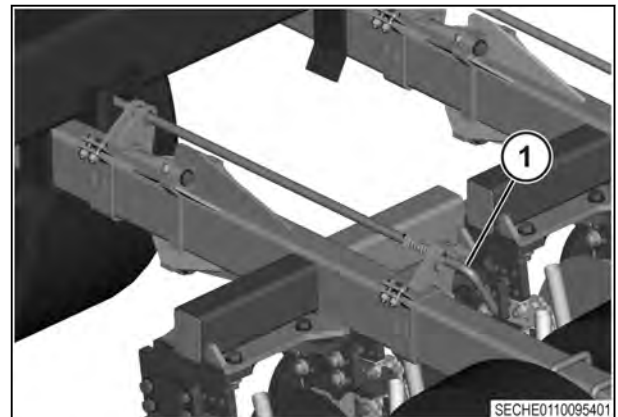

Fig. 21

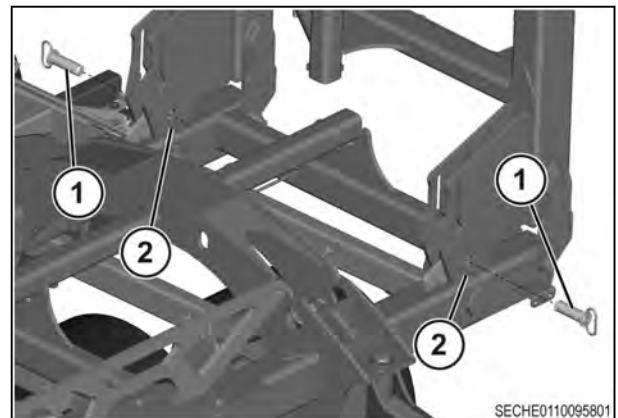

Fig. 22

12. Use the tractor hydraulics to lower the toolbars and move the hydraulic lever to full down position. Use the dial (1) on the down pressure control box to set the initial down pressure.
13. Stop the engine and take the ignition key with you.

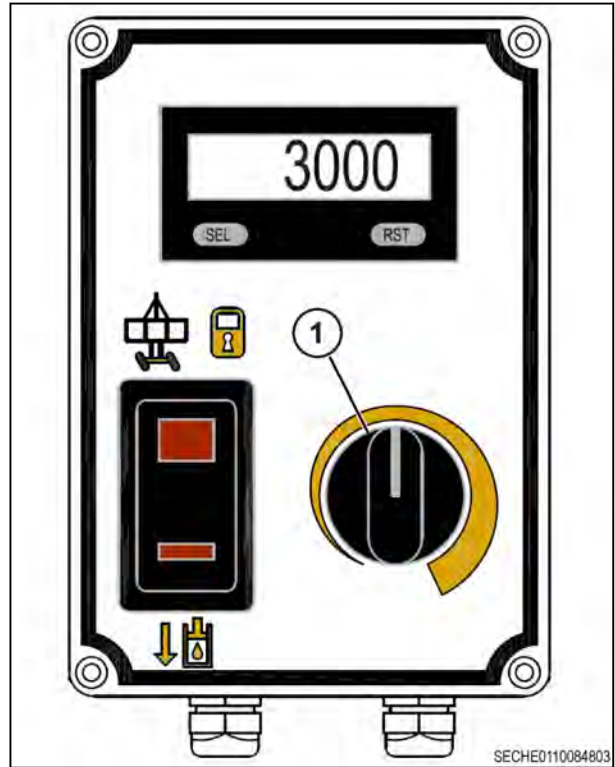

Fig. 23

14. Install the initial sequence of seed depth collars (1) on the shafts of the frame height cylinders (2).
15. Prepare the air cart for seeding.
16. Check the seed depth and the down pressure of the drill. Make the needed adjustments.

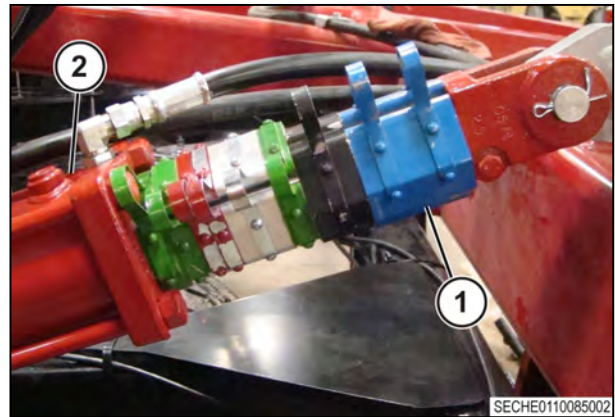

Fig. 24

### 3.6 Packing tires

The packing tires (1) located behind the opening disc assemblies (2) close the two furrows made by each of the opening discs.

The packing tires operate at an angle to the travel of the drill. The angle closes the two furrows and removes any accumulated mud from the tires when operating in wet soil conditions. The packing tires on the right-hand side of the drill are angled toward the right-hand side of the drill. The packing tires on the left-hand side of the drill are angled toward the left-hand side.

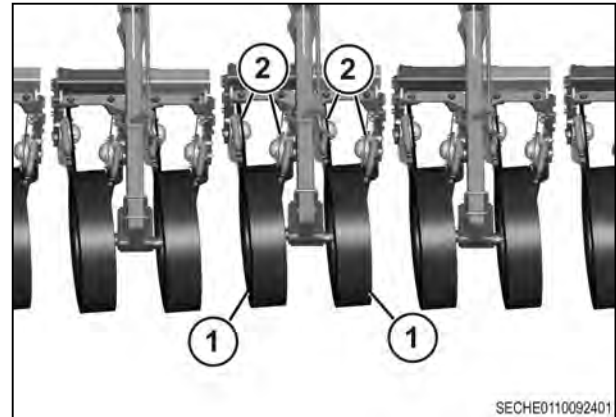

Fig. 25

#### 3.6.1 Packing tire air pressure

Soil Condition	Tire Air Pressure
Dry Soil	69 to 103 kPa (10 to 15 psi)
Wet Soil	As low as 55 kPa (8 psi)

**NOTE:** Lower the air pressure inside the packing tires when operating in wet soil conditions. The lower tire air pressure allows the side wall of the packing tire to flex more and shed any accumulated mud.

### 3.7 Seed depth

Seed depth is how deep the drill plants the seed in the ground. The seed depth changes in relationship to how close the frame of the drill is to the ground. The closer the frame is to the ground; the deeper the drill plants the seed.

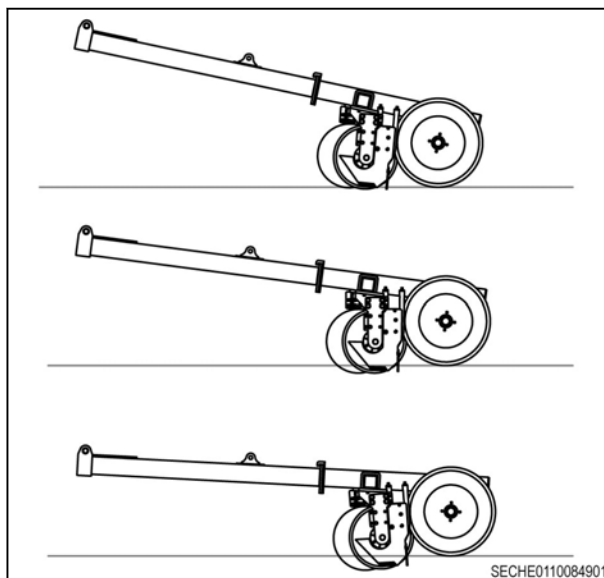

Fig. 26

Adjust the seed depth by installing depth collars (1) on the shafts of the frame height cylinders (2). Install the same sequence of depth collars on each frame height cylinder.

There are four different widths of depth collars. The color of the depth collar identifies the width of the depth collar. The following is the color and width of each depth collar.

- Blue = 7.62 cm (3.0 inch)
- Silver = 3.81 cm (1.5 inch)
- Green = 1.91 cm (0.75 inch)
- Red = 1.27 cm (0.50 inch)

Different sequences of depth collars will cause different seed depths. Use the best sequence of depth collars for the field conditions.

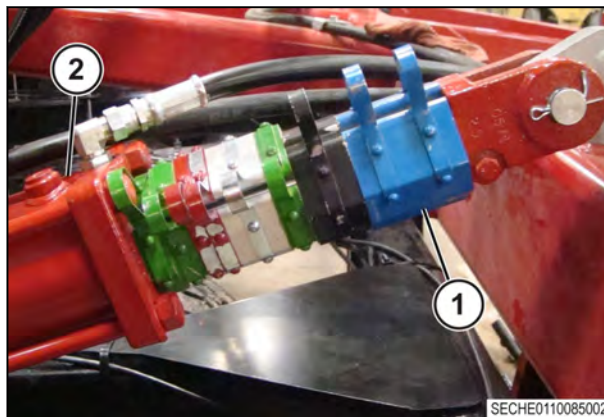

Fig. 27

#### 3.7.1 Checking the seed depth

Check the seed depth in the field before seeding with the machine.

##### Procedure

1. Connect the machine to a tractor of the correct size to operate the machine.
2. Set the seed depth of the machine by installing the initial sequence of the seed depth collars.
3. Fill the seed hopper or seed container with seed.
4. Put all the components of the machine in the field position.
5. Lower the machine and plant a straight section at the needed speed for approximately 55 m (30 yd).
6. Stop the tractor. Stop the engine, apply the tractor park brake, and take the ignition key with you. Find one of the furrows behind the machine.

7. Carefully remove the soil covering four of the planted seeds.



Fig. 28

8. Measure the distance from the surface of the soil to the bottom of each seed. Use one of the following two methods.
  - **Using a ruler and a straight edge:** Place the straight edge flat against the surface of the ground. Hold a ruler vertically in the seed furrow next to the seed. Measure the distance from the bottom of the seed to the bottom of the straight edge.
  - **Using the seed finding tool:** Place the long flat section (1) of the seed finding tool against the ground with the short flat section (2) inside the seed furrow (3). Press the short flat section in the ground until the long flat section is flush with the ground. Measure the depth of the furrow using the marks on the short flat section.



Fig. 29

### Result

The measurement taken is the actual seed depth.

9. Check the depth of the seeds in two of the other furrows behind the machine.
10. Compare the measurements to the correct seed depth and adjust the machine as necessary.

### After finishing the procedure

Continue to check the seed depth until the machine plants the seed at the correct seed depth.

## 3.7.2 Seed depth collar sequences

Each letter in the following chart represents the color of the depth collar.

- B = Blue
- S = Silver
- G = Green
- R = Red

The two rows of numbers below the letters in the chart are the total length of the depth collars in inches and centimeters.



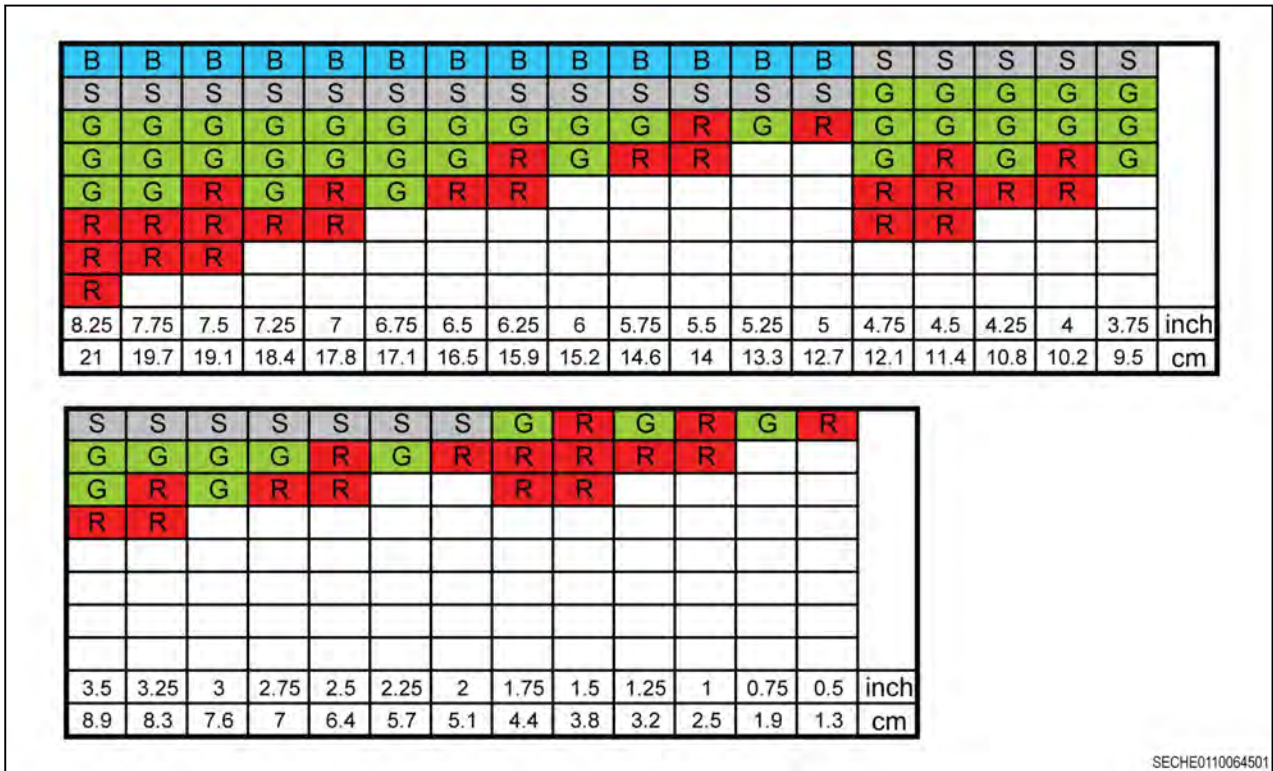

SECHE0110064501

Fig. 30

### 3.7.3 Initial seed depth collar sequences

The initial seed depth collar sequence is the total length of the depth collars installed on the shaft of the frame height cylinders. The initial seed depth collar sequence is a starting point. The sequence of depth collars will change with the field conditions.

Use the following initial seed depth collar sequences when checking seed depth.

- Small Grains and Beans: 12.7 cm (5 inch) sequence (blue (1), silver (1), red (1))
- Canola: 17.8 cm (7 inch) sequence (blue (1), silver (1), green (2), red (2))

### 3.7.4 Adjusting seed depth

**Procedure**

1. Raise the drill frame to the highest height.
2. Install the recommended initial sequence of depth collars (1) on the shaft of each of the frame height cylinders (2).

**NOTE:** See the decal on the front of the frame for the sequence of seed depth collars.

3. Operate the drill in the field and check the seed depth.
4. Adjust the sequence of seed depth collars. Check the seed depth until the seed is at the correct seed depth.

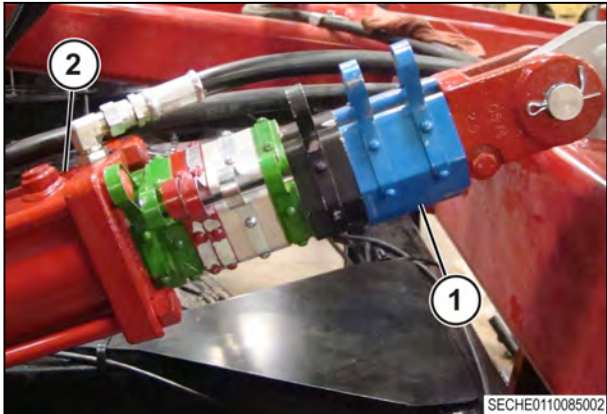

Fig. 31

SECHE0110085002

### 3.8 Toolbar down pressure

A hydraulic cylinder (1) applies toolbar down pressure on each toolbar (2). The cylinders apply a constant down pressure through the full range of movement of the toolbar. An active hydraulic circuit maintains uniform pressure to each hydraulic cylinder.

**NOTE:** *On drills equipped with a hydraulic lift assist hitch, the hydraulic lift assist hitch applies additional down pressure when seeding. The hydraulic lift assist hitch applies down pressure automatically as the toolbar down pressure is set.*

Use the toolbar down pressure control box to set the toolbar down pressure. The toolbar down pressure can be adjusted from 1034 to 17237 kPa (150 to 2500 psi). Set the toolbar down pressure high enough for correct disc penetration and correct soil compaction. The toolbar down pressure adjustment will change with field conditions, seed depth, soil type, and ground speed.

Operate the tractor hydraulic remote that the toolbar down pressure is connected at full output or fully open. Operating the hydraulic remote at full output reduces the back pressure on the toolbar down pressure return lines.

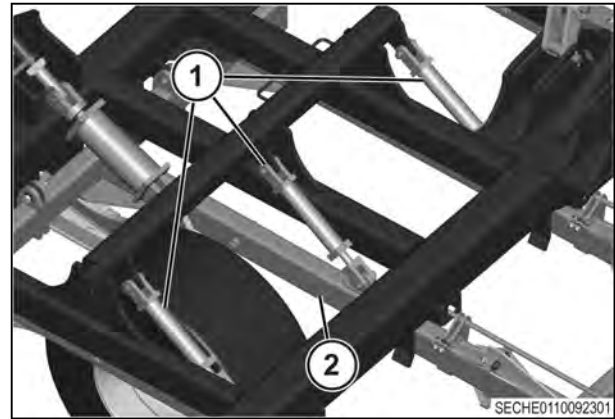

Fig. 32

#### 3.8.1 Down pressure control box

Use the down pressure control box to adjust the down pressure on each of the toolbars. On machines equipped with a hydraulic lift assist hitch, the down pressure control box also engages the hydraulic caster lock.

Find the following components on the down pressure control box.

- **LCD read out (1):**The LCD readout displays the toolbar down pressure in pounds per square inch (psi).
- **Mode switch (2):**The mode switch is a three position switch. The mode switch is used as a power switch and to switch between setting down pressure (4) and engaging the hydraulic caster lock (5) on hydraulic lift assist hitches. The middle switch position turns off the down pressure control box.
- **Adjustment knob (3):**The adjustment knob is used to set the toolbar down pressure.

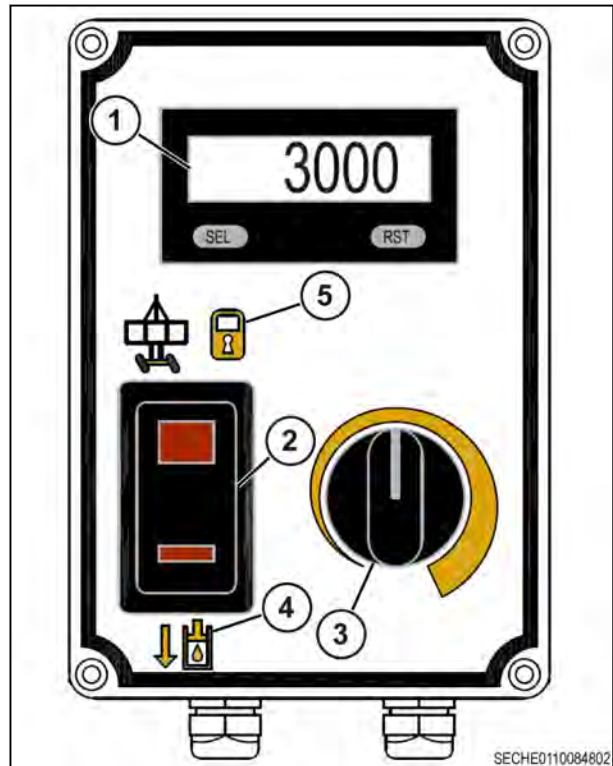

Fig. 33

## 3.8.2 Setting the toolbar down pressure

### Before starting the procedure

The toolbar down pressure is set in the field. Before the toolbar down pressure can be set, transport the drill to the field and prepare the drill to plant.

Check the toolbar down pressure before seeding with the drill.

### Procedure

1. Operate the drill in the field.
2. Stop the tractor. Stop the engine, apply the tractor park brake, and take the ignition key with you.
3. At the rear of the drill, inspect the tracks made by the packing tires.
  - If the track is very light or not present, increase the toolbar down pressure.
  - If the track is too deep and the soil is too compacted, decrease the toolbar down pressure.

Adjust the down pressure in the operator cab with the toolbar down pressure control box.

4. Operate the drill in the field and check the results of the adjustment. Continue to adjust the toolbar down pressure until the packing tire compacts the soil correctly.



### 3.9 Turning at the edge of a field

When turning at the edge of a field, or headland, complete the following steps.

#### Procedure

1. When approaching the turn, slow the tractor and machine to an acceptable rate of speed to complete the turn.
2. Begin to raise the frame of the machine and start the turn at a point where the machine will clear any obstacles to the outside of the turn.  
**IMPORTANT:** *When lifting the machine for a turn, only lift the frame with the frame height cylinders.*
3. Complete the turn. Watch and make sure the edge of the machine clears any obstacles.
4. After completing the turn, align the machine with the last pass, permitting for the correct amount of spacing or overlap.
5. Lower the frame of the machine to start the next pass.
6. Increase the speed of the tractor and machine to the operating speed.

## 3.10 Hydraulic lift assist

### 3.10.1 Hydraulic lift assist hydraulic caster lock

The hydraulic lift assist rear hitch is equipped with a hydraulic caster lock. The hydraulic caster lock is used to hydraulically lock the caster wheels in position.

**NOTE:** *The hydraulic caster lock will lock the wheels in any position. Make sure the wheels are pointing straight forward before locking the wheels with the hydraulic caster lock.*

The hydraulic caster lock is used when backing up the drill.

**IMPORTANT:** *Do not use the hydraulic caster lock when transporting the drill. Use the caster lock pins when transporting the drill.*

Lock the hydraulic caster lock with the mode switch (1) on the down pressure control box.

Push the top section of the mode switch to engage the hydraulic caster lock (2).

Push the bottom section of the mode switch to disengage the hydraulic caster lock.

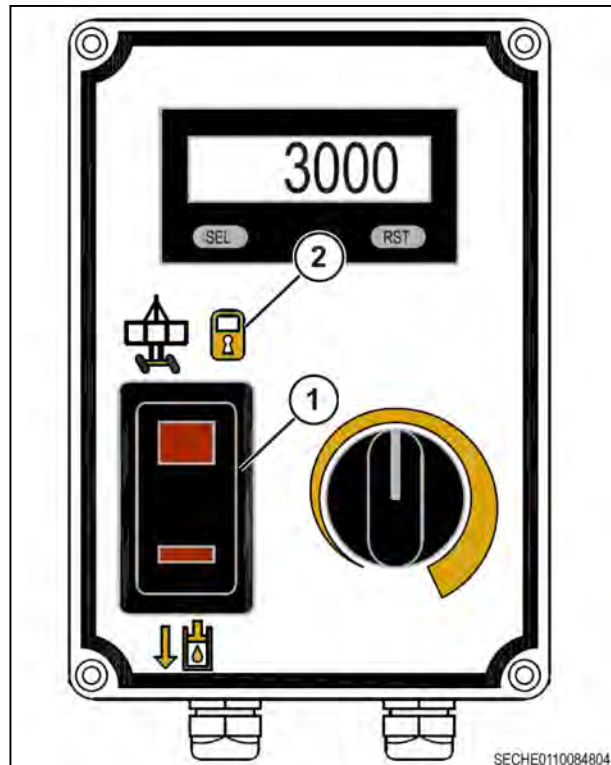

Fig. 34

### 3.10.2 Hydraulic lift assist pressure gauge

On machines equipped with a hydraulic lift assist hitch, a hydraulic lift assist pressure gauge (1) is installed toward the right-hand side of the front hitch.

Use the hydraulic lift assist pressure gauge when preparing the drill for transport. Lifting the wings for transport charges the hydraulic lift assist accumulator. Use the hydraulic lift assist pressure gauge to make sure the hydraulic system charges the hydraulic lift assist accumulator correctly.



Fig. 35

The hydraulic lift assist pressure gauge displays three zones:

- **Seeding (1):** The gauge needle must be in the seeding zone when seeding.

**NOTE:** *If the gauge needle is above the seeding zone when seeding, make sure the hydraulic lift assist lock-out is in the open position.*

- **Red (2):** When the gauge needle is in the red zone the hydraulic lift assist accumulator is either not adequately charged or is over charged.
- **Green (3):** When the gauge needle is in the green zone the hydraulic lift assist is adequately charged and the hydraulic lift assist lock-out can be closed.

**IMPORTANT:** *The gauge needle must be in the green zone before transporting the drill. Transporting the drill with the gauge needle in the red or seeding zone will cause damage to the frame and tires.*

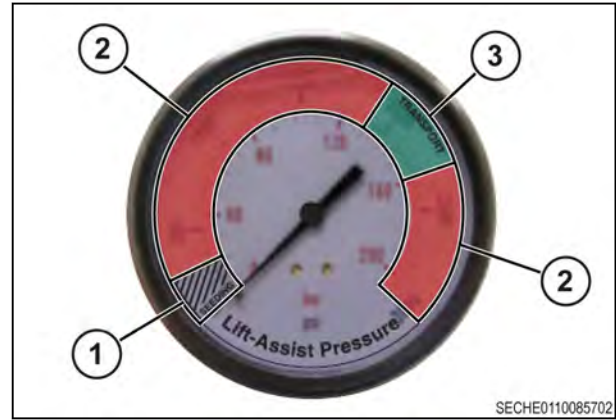

Fig. 36

## 3.11 NH3 system



### DANGER:

**Do not breathe anhydrous ammonia gas. Anhydrous ammonia gas is very hazardous. Make sure to use the correct protective equipment and practices when around anhydrous ammonia.**

Use the optional NH3 system and follow the manufacturer's instructions when applying anhydrous ammonia while seeding. The NH3 system monitors and controls the application of the anhydrous ammonia. A display located in the operator cab of the tractor shows the monitored information.

**NOTE:** Consult the Operator Manual for the display in the tractor for operating instructions for the display.

The NH3 system uses the CAN network to transfer the information to the display in the operator cab of the tractor.

### 3.11.1 NH3 menu buttons

The NH3 menu buttons (1) will be located to the right-hand side of the screen. The menu buttons are either used to access other screens in the NH3 system or perform specific functions.

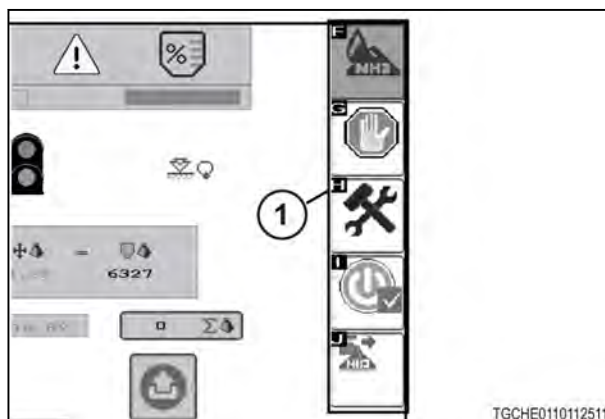

Fig. 37

The following menu buttons are used in the NH3 system.

Icon	Description
	<b>NH3 work screen button:</b> Press the NH3 work screen button to display the NH3 work screen.
	<b>Manual work switch button:</b> Press the manual work switch button to engage and disengage the counters on the NH3 work screen.
	<b>NH3 settings screen button:</b> Press the NH3 settings screen button to display the NH3 settings screen.
	<b>Product on/off button:</b> Press the product on/off button to switch the product shut off valve on and off.
	<b>NH3 purge button:</b> Press the NH3 purge button to purge any air from the lines carrying the anhydrous ammonia.

### 3.11.2 NH3 system work screen

Important information is entered and shown on the NH3 work screen. The following information is displayed or entered in the NH3 work screen.

**NOTE:** Information is also entered in the settings screen of the NH3 system.

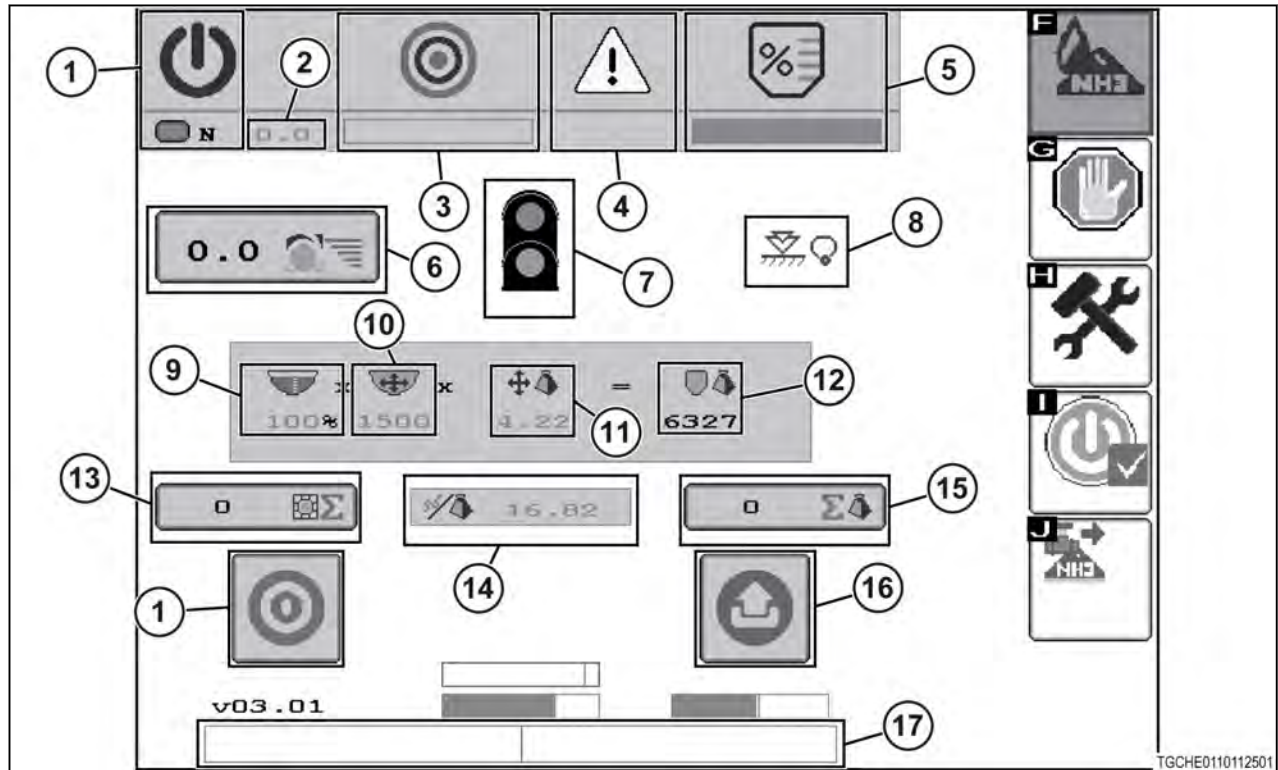

Fig. 38

- |                                |                                |
|--------------------------------|--------------------------------|
| (1) Product on/off             | (10) Tank size                 |
| (2) Target rate                | (11) Product density           |
| (3) Actual rate                | (12) Product weight            |
| (4) Alarms                     | (13) Applied area              |
| (5) Bin fill percentage        | (14) Liquid calibration number |
| (6) Speed and speed type       | (15) Applied weight            |
| (7) Seeding indicator          | (16) Task controller on/off    |
| (8) Toolbar position indicator | (17) AMPS                      |
| (9) Tank fill percentage       |                                |

### 3.11.3 Product on/off buttons

The product on/off button (1) is located in three areas on the display screen.

Use the product on/off button to toggle the shut-off valve on and off.

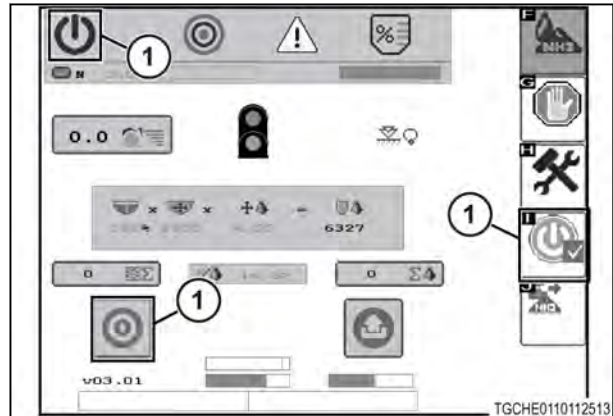

Fig. 39

### 3.11.4 Product on/off indicator

The product on/off indicator (1) is located at the top left-hand corner of the display screen. The product on/off indicator shows the condition of the product shut-off valve.

If the indicator is green the product shut-off valve is open.

If the indicator is red the product shut-off valve is closed.

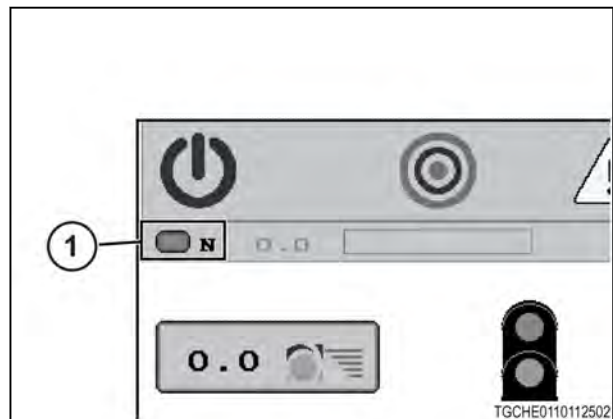

Fig. 40

### 3.11.5 Target application rate

The target application rate (1) is displayed in the top left-hand corner of the display screen. The target application rate is the rate of application the operator has entered. The target application rate is shown in kg/ha (lbs/acre).

Enter the target application rate by selecting the value on the screen and entering the rate of application.

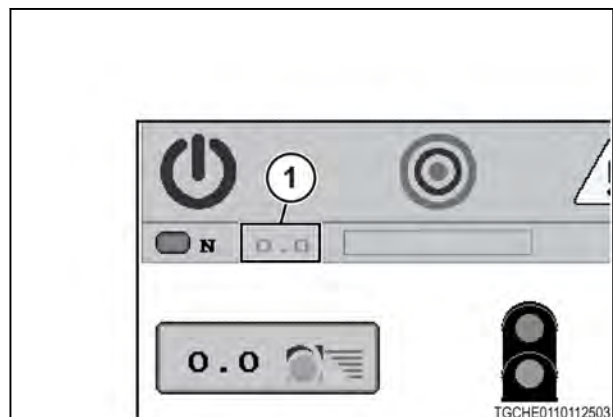

Fig. 41

### 3.11.6 Actual application rate

The actual application rate bar graph (1) is shown in the top left-hand corner of the display screen. The actual application rate bar graph is the actual rate of application of anhydrous ammonia. The actual application rate bar graph represents a percentage of the target application rate. The bar graph represents from zero to 200 percent of the target application rate. When the bar graph is in the middle of the range the drill is applying the target application rate to the field.

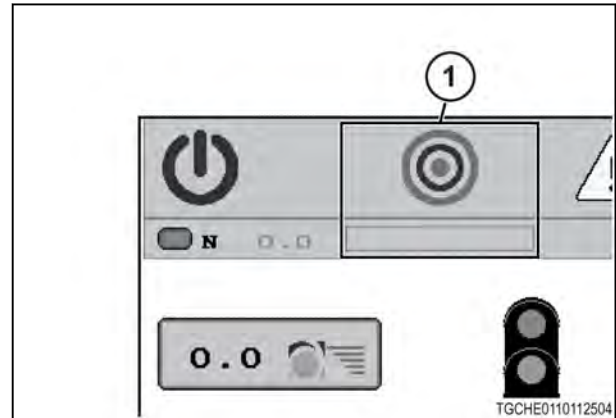

Fig. 42

### 3.11.7 Ground speed

The ground speed (1) is the speed that the tractor and drill are moving. The ground speed is shown in mph (kph).

Select the box containing the ground speed to select between the four different types of ground speed input. A specific icon for the type of ground speed input will appear adjacent to the ground speed value when selected. The following types of ground speed inputs can read the ground speed.

Icon	Description
	<b>External speed:</b> The default ground speed input. The ground speed is input to the cart ECU.
	<b>ECU speed:</b> Direct ground speed input to the ECU.
	<b>ISO ground speed:</b> Ground speed input from the tractor GPS.
	<b>ISO wheel speed:</b> Ground speed input from the tractor wheel speed or the radar.

**NOTE:** The two ISO speeds are only available if the tractor is connected to the ISO-BUS network and is transmitting the ground speeds.

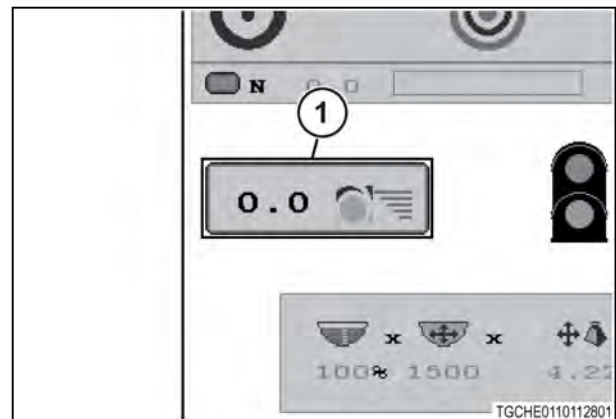

Fig. 43



### 3.11.8 Seeding indicator

The seeding indicator (1) shows the current status of seeding.

The seeding indicator will show red when the machine is not planting.

The seeding indicator will show green when the machine is planting.

**NOTE:** A green seeding indicator will only display when the toolbar position icon shows down, the work switch icon is green, and the tractor is moving.

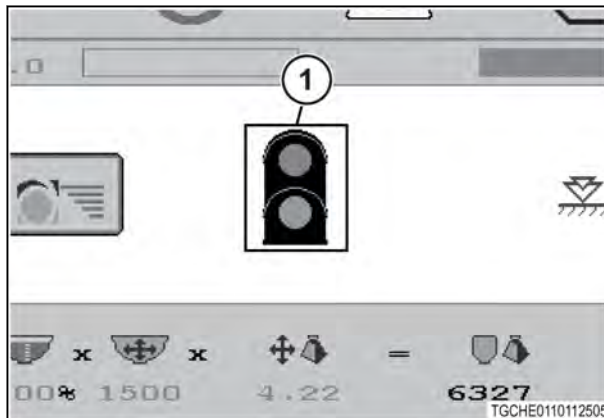

Fig. 44

### 3.11.9 Toolbar position

The toolbar position icon (1) shows the current position of the toolbars. The icon will change when the toolbar position changes.

Icon	Description
	<b>Toolbar up icon:</b> When the toolbars are up the display will show the toolbar up icon.
	<b>Toolbar down icon:</b> When the toolbars are down the display will show the toolbar down icon.

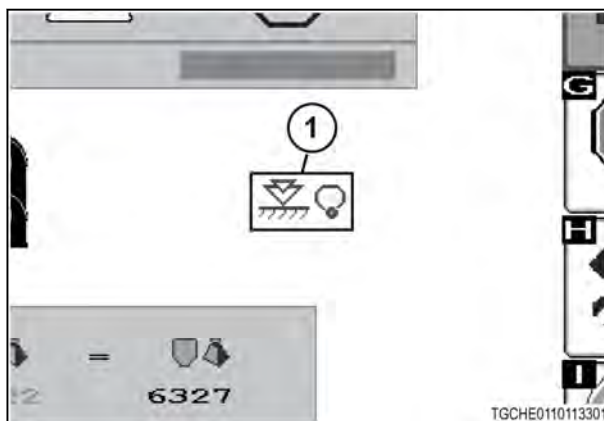

Fig. 45

**NOTE:** On machines without a work switch, the toolbar position icon will always show the down position icon.

### 3.11.10 Tank fill percentage

The tank fill percentage (1) shows the percentage of the tank filled with product. The tank fill percentage is used to calculate the product weight.

Enter the tank fill percentage by selecting the tank fill percentage value (2).

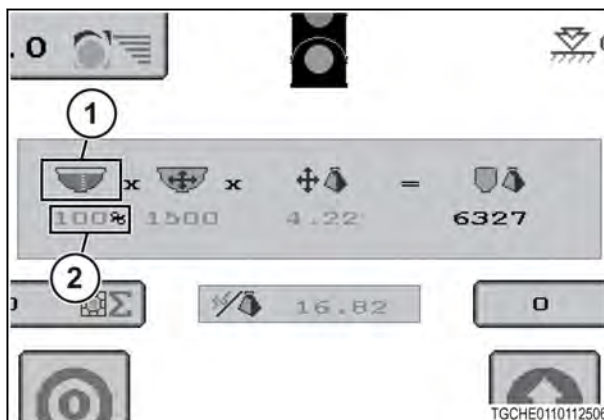

Fig. 46



### 3.11.11 Tank size

The tank size (1) is the size of tank used to hold the product. The tank size is used to calculate the product weight.

Enter the tank size by selecting the tank size value (2).

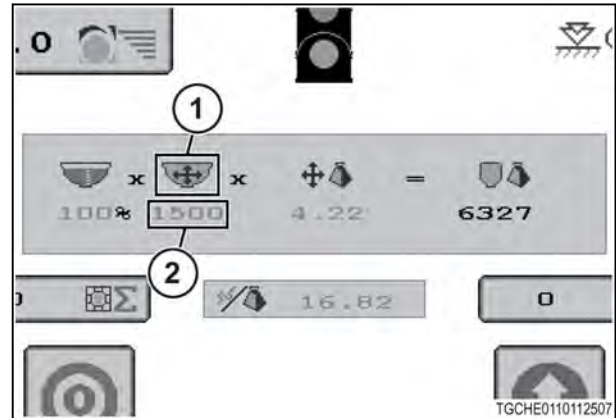

Fig. 47

### 3.11.12 Product density

The product density (1) is the weight of the product for a given volume. The product density is used to calculate the product weight.

To system calculates the product density by dividing the weight of the product in the tank by the volume of product in the tank.

**NOTE:** Anhydrous ammonia contains 0.5 kg/L (4.22 lbs/gal) of nitrogen.

Enter the product density by selecting the product density value (2).

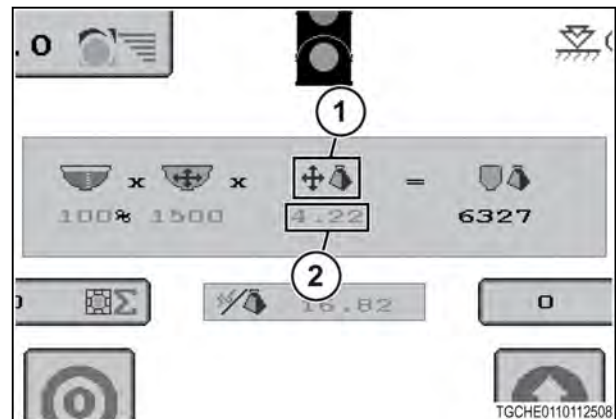

Fig. 48

### 3.11.13 Product weight

The product weight (1) is the weight of the product in the tank. The product weight is calculated using the entered tank fill percentage, tank size, product density values.

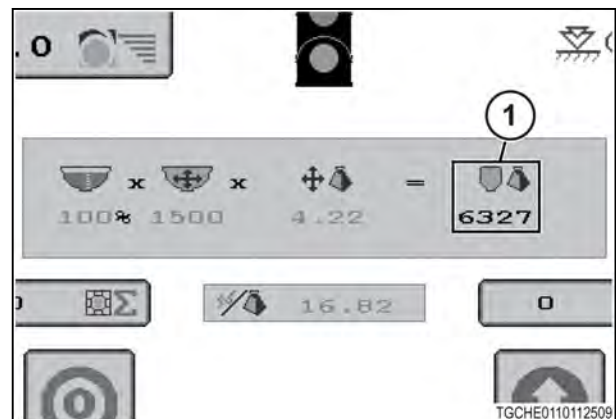

Fig. 49

### 3.11.14 Applied area counter

The applied area counter (1) displays the amount of area that the machine has applied product. The area is displayed as ha (ac).

Set the applied area counter to zero by selecting the box containing the applied area counter.

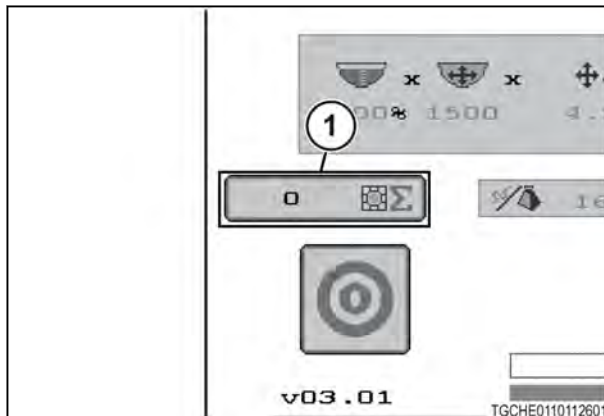

Fig. 50

### 3.11.15 Applied weight counter

The applied weight counter (1) displays the total weight of product that the machine has applied. The weight is displayed in Kg (lbs).

Set the applied weight counter to zero by selecting the box containing the applied weight counter.

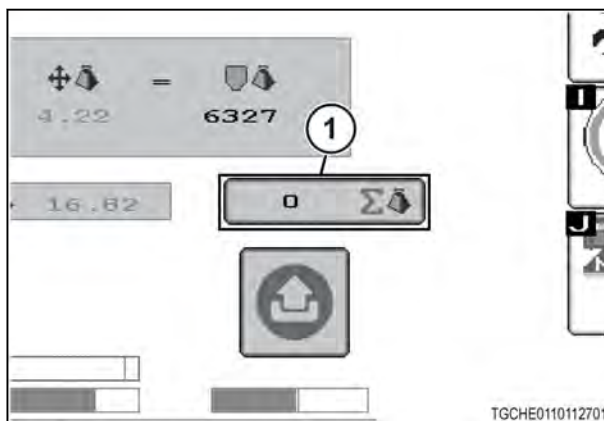

Fig. 51

### 3.11.16 Liquid calibration number

The liquid calibration number (1) is calculated using the calibration number of the flow meter installed on the tank and the actual weight of nitrogen per unit of anhydrous ammonia.

Enter the liquid calibration number by selecting the liquid calibration number value (2).

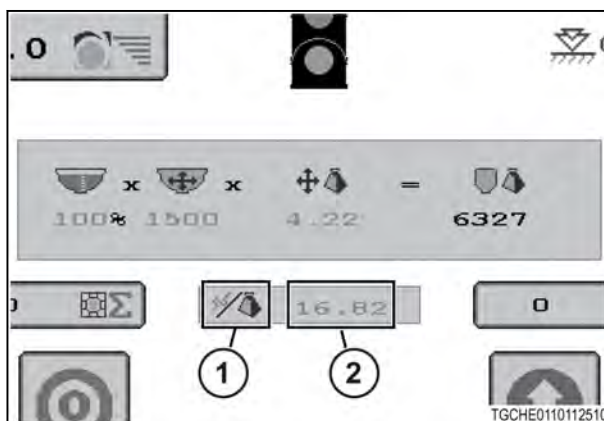

Fig. 52

### 3.11.17 Calculating the liquid calibration number

#### Procedure

1. Locate the calibration number tag on the flow meter installed on the anhydrous ammonia tank.

The units of the calibration number will be different depending on the brand of the flow meter. The calibration number can be listed in the following units.

- Pulses per pound of product
- Pulses per 10 gallons of liquid
- Pulses per gallon of liquid

**NOTE:** The calibration number can be different from the units shown. Make sure to take note of the units of the calibration number.

- Convert the calibration number of the flow meter to pulses per pound of actual nitrogen.

**NOTE:** There are 1.91 kg (4.22 lbs) of actual nitrogen in one gallon of anhydrous ammonia.

- Enter the value of the converted calibration number as the liquid calibration number in the display.

For example, the calibration number of the flow meter is 710 pulses/10 gallons. First, divide 710 pulses by 10 gallon to reach 71 pulses/gallon of anhydrous ammonia. Then, divide 71 pulses by 4.22 lbs of actual nitrogen to reach 16.82 pulses/lbs of actual nitrogen.

### 3.11.18 Verifying the liquid calibration number

Verify the entered liquid calibration number of the NH<sub>3</sub> system whenever a new number is entered.

#### Procedure

- Enter the calculated liquid calibration number in the NH<sub>3</sub> work screen.
- Weigh the filled anhydrous ammonia tank.
- Apply the contents of the weighed anhydrous ammonia tank until the tank is empty.
- Weigh the empty anhydrous ammonia tank.
- Subtract the weight of the empty anhydrous tank from the filled anhydrous tank.

#### Result

The resulting number is the weight of the applied anhydrous ammonia.

- Calculate the actual application rate by dividing the weight of applied anhydrous ammonia by the total acreage the anhydrous ammonia was applied.
- Compare the actual application rate to the target application rate.
- If necessary, adjust the liquid calibration number (1) on the NH<sub>3</sub> main work screen. Verify the new liquid calibration numbers. Adjust the liquid calibration number by selecting the value (2) adjacent to the icon.
  - Increase the liquid calibration number to increase the actual application rate.
  - Decrease the liquid calibration number to decrease the actual application rate.

**NOTE:** Increase the liquid calibration number by 0.1 to 0.2 points at a time. Verify the new numbers until the drill is applying the target application rate.

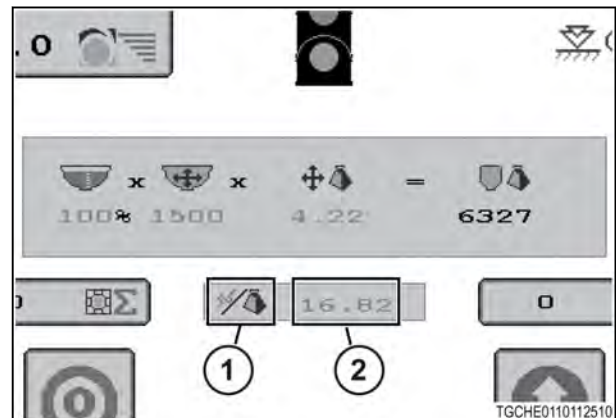

Fig. 53

### 3.11.19 Purging air from the system

#### Before starting the procedure



#### **DANGER:**

**Do not breathe anhydrous ammonia gas. Anhydrous ammonia gas is very hazardous. Make sure to use the correct protective equipment and practices when around anhydrous ammonia and follow the manufacturer's instructions for the correct use.**

Purge air from the lines and tubes of the anhydrous ammonia system whenever a tank is connected to the machine.

**Procedure**

1. Put the tractor and machine so the tractor is upwind of the machine.
2. Make sure all people and pets are clear of the area before purging the anhydrous ammonia system.
3. Select the NH3 purge menu button (1) on the display in the tractor cab.

**Result**

The control valves on the anhydrous ammonia system will open and let the system to purge for six seconds.

4. After the six seconds, make sure that the NH3 purge menu button indicates that the system has closed the control valve.
5. Let enough time pass for the purged anhydrous ammonia to dissipate before exiting or permitting anybody to going near the machine.

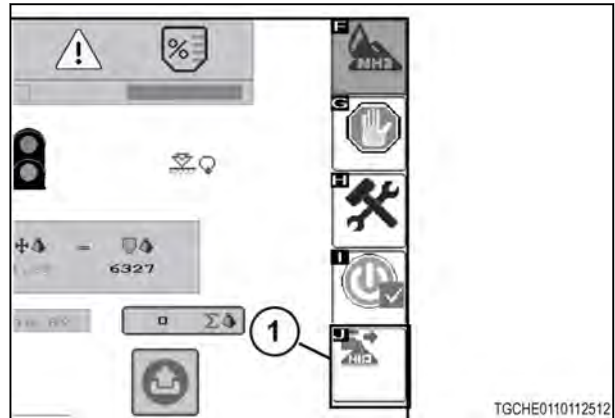

Fig. 54

**3.11.20 NH3 system settings screen**

The following information is entered and displayed in the NH3 system settings screen.

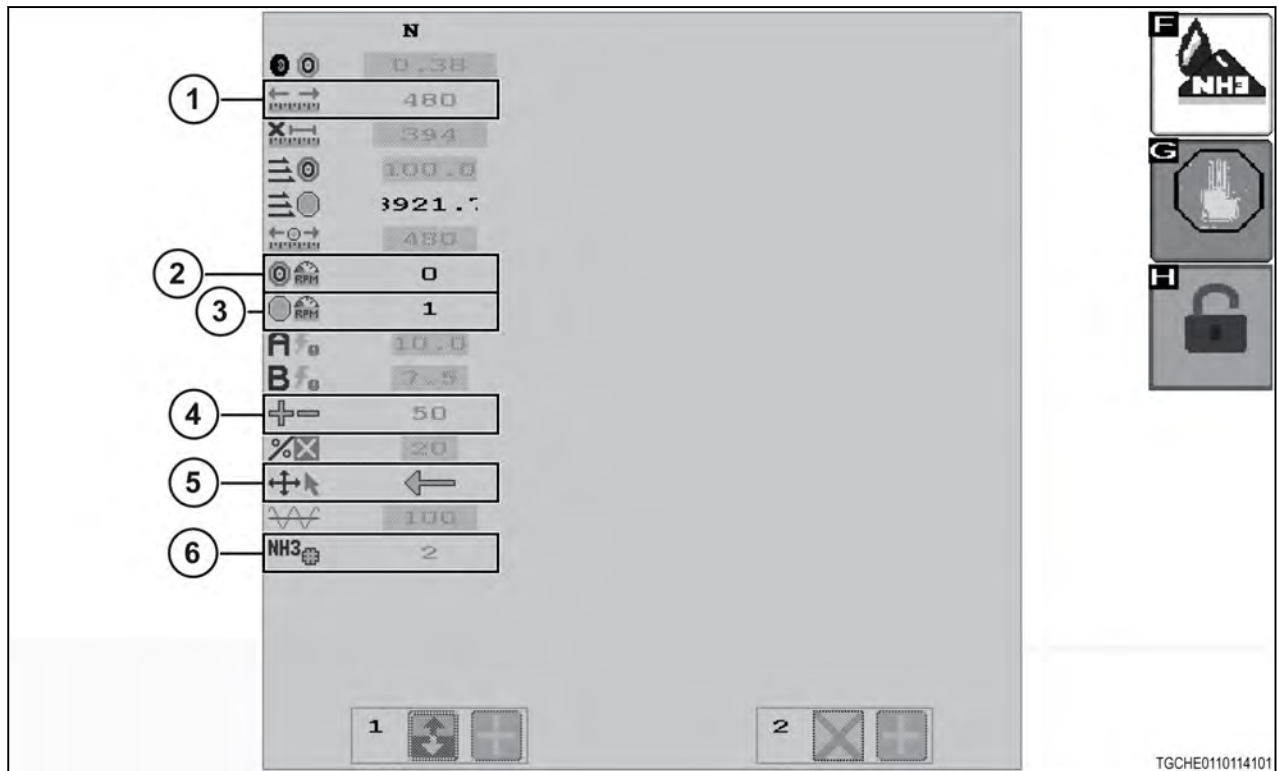

Fig. 55

- |                   |                        |
|-------------------|------------------------|
| (1) Machine width | (4) Control valve gain |
| (2) Target rpm    | (5) Drive direction    |
| (3) Actual rpm    | (6) Number of valves   |

### 3.11.21 Machine width

Enter the machine width in the NH3 system settings screen. Enter the machine width in inches. To change the implement width select the value (1) adjacent to the implement width icon (2).

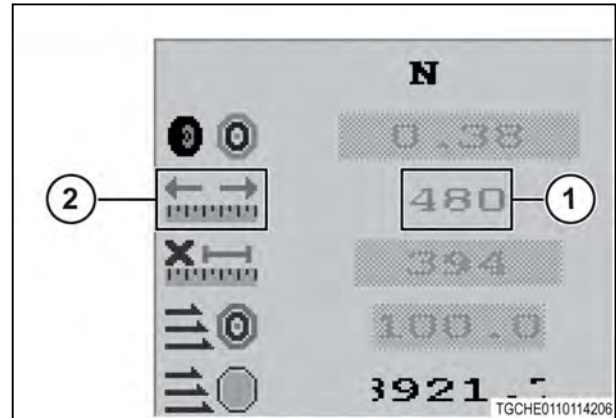

Fig. 56

### 3.11.22 Target flow of the flow-meter

The NH3 system settings screen shows the target flow of the flow-meter (1). The target flow of the flow-meter is a value calculated from the current implement speed, entered calibration values, implement width, and target rate.

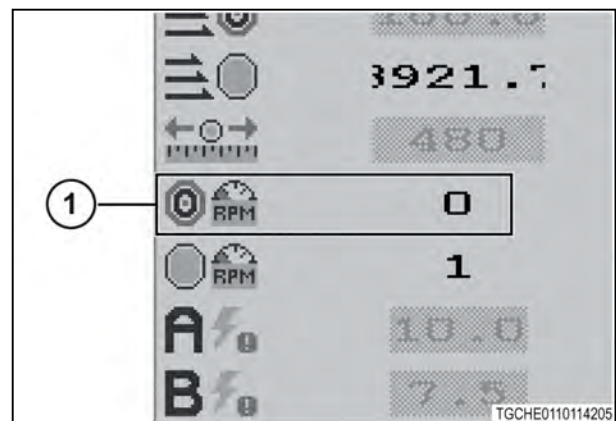

Fig. 57

### 3.11.23 Actual flow of the flow-meter

The NH3 system settings screen shows the actual flow of the flow-meter (1). The actual flow of the flow-meter is the observed rpm of the liquid flow-meter.

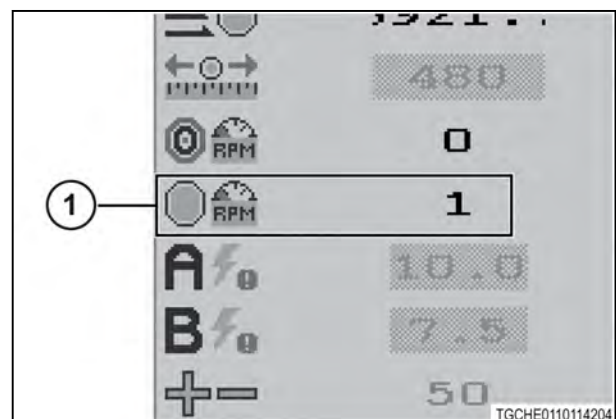

Fig. 58



### 3.11.24 Control valve gain

Control valve gain is the speed at which the control valve changes when the NH3 system sends the open or close signal. Change the control valve gain by selecting the value (1) adjacent to the control valve gain icon (2).

Use an initial gain value of 50 when adjusting the control valve gain. Increase the value for a faster reaction from the control valve. Decrease the value for a slower reaction from the control valve.

**NOTE:** Motors and actuators have a maximum gain value. When the maximum gain value is reached the motor or actuator will not react any faster.

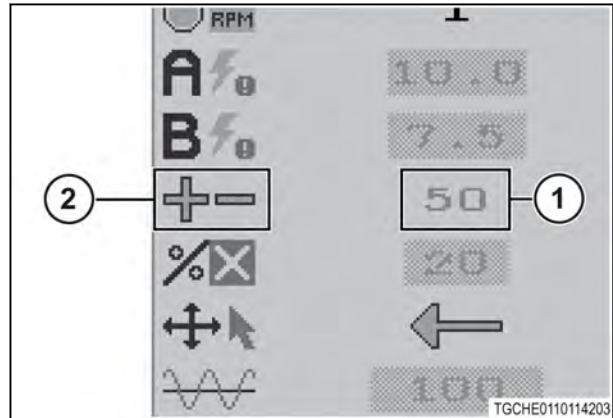



Fig. 59

### 3.11.25 Valve polarity

Enter the valve polarity of the control valve in the NH3 system settings screen. Change the valve polarity by selecting the arrow (1) adjacent to the valve polarity icon (2).

The valve polarity is the polarity of the solenoid that controls the control valve. The valve polarity can be either forward polarity or reverse polarity.

Icon	Description
	When the valve is forward polarity, the system sends voltage through the red wire to open the valve and through the green wire to close the valve.
	When the valve is reverse polarity, the system sends voltage through the green wire to open the valve and through the red wire to close the valve.

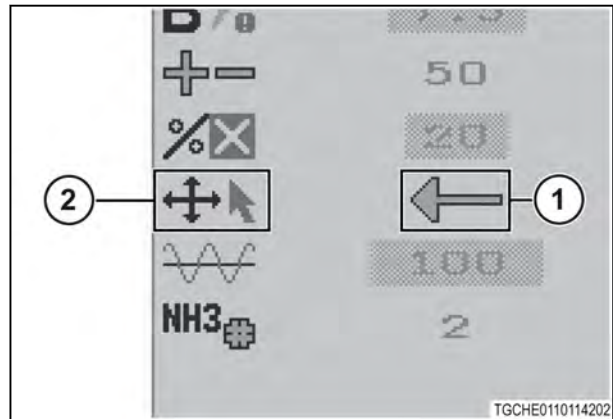

Fig. 60

### 3.11.26 Number of valves

The number of valves used in the anhydrous ammonia distribution system is entered in the NH3 system setup screen. The default number of valves is 2. Select the value (1) next to the number of valves icon (2) to change the number of valves.

When the entered number of valves is one, the control valve is commanded to close when the work switch is off.

When the entered number of valves is two, the control valve does not change position when the master work switch is off. The NH3 system will command the shut off valve to close.

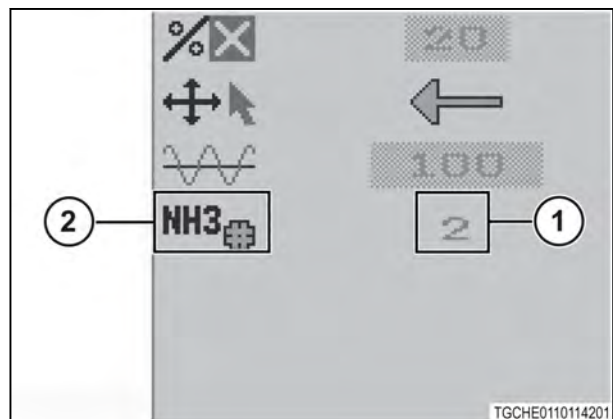

Fig. 61

---

## 4. Maintenance

<b>4.1 Lubrication and maintenance chart</b> .....	81
<b>4.2 Grease fitting locations</b> .....	82
<b>4.3 Leveling the drill frames</b> .....	86
<b>4.4 Opening disc scraper adjustment</b> .....	87
4.4.1 Adjusting the opening disc scraper .....	87
<b>4.5 Opening disc offset</b> .....	88
4.5.1 Setting opening disc offset .....	89
<b>4.6 Frame height cylinder phasing</b> .....	90
4.6.1 Putting the frame height cylinders in phase .....	90
<b>4.7 Bleeding air from the hydraulic system</b> .....	91
<b>4.8 Storage</b> .....	92
4.8.1 Preparing the drill for storage .....	92
4.8.2 Removing the drill from storage .....	92





## 4.1 Lubrication and maintenance chart

16 hour or Daily Lubrication		
Component	Fittings	Description
Transport Wheel Walk Beams	2	Lubricate two fittings on each transport wheel walk beam.
Transport Wheel Struts	2	Lubricate two fittings on each transport wheel strut.
Rear Hitch Pivots	2	Lubricate one fitting in each pivot pin of the rear hitch.
Fertilizer Bander Strut Pivots	2	Lubricate one fitting on each bander disc strut on the fertilizer bander attachment.
Hydraulic Lift Assist Tie Rod	2	Lubricate one fitting on each end of the tie rod of the hydraulic lift assist rear hitch.
Hydraulic Lift Assist King Pin	2	Lubricate one fitting on each king pin of the hydraulic lift assist rear hitch.

50 hour or Weekly Lubrication		
Component	Fittings	Description
Wing Frame Hinge Point	4	Lubricate one fitting on each pivot point of the wing frames.
Wing Fold Links	4	Lubricate two fittings on each wing fold link. <b>NOTE:</b> <i>On the five-section frames only.</i>
Ring Hitch	2	Lubricate two fittings on the ring hitch.

50 hour or Weekly Maintenance	
Component	Description
Hardware Torque	Complete an inspection of all hardware installed on the machine for proper torque. Make sure the hardware securing the wing frames, main frame wheels, and wing support wheels is tight.
Wheel Lug Nut Torque	Make sure all of the wheel lug nuts are tightened to the correct torque.
Tire Air Pressure	Make sure all of the tires are inflated to the correct air pressure.

1000 hour or Seasonal Lubrication		
Component	Fittings	Description
Packing Wheel and Disc Hubs	1	Lubricate one fitting on each packing wheel and disc hub.

1000 hour or Seasonal Maintenance	
Component	Description
Hydraulic Caster Lock Oil Level	Check the oil level in the hydraulic caster lock cylinder. <b>NOTE:</b> <i>On hydraulic lift assist hitches only.</i>

## 4.2 Grease fitting locations

### Transport wheel walk beams

The 9.14 m (30 ft) drill has two transport wheel walk beams.

All other drill frames have four transport wheel walk beams.

Find the grease fittings (1) on each transport wheel walk beam, on the top and bottom of the beam.

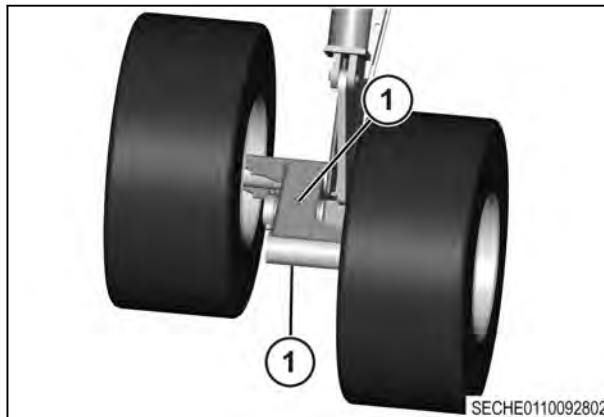

Fig. 1

### Transport wheel struts

The 9.14 m (30 ft) and the 12.19 m (40 ft) drills have four transport wheel struts.

The 15.24 m (50 ft) and the 18.29 m (60 ft) drills have six transport wheel struts.

Find the two grease fittings (1) on each transport wheel strut (2), on the front pivot of the strut.

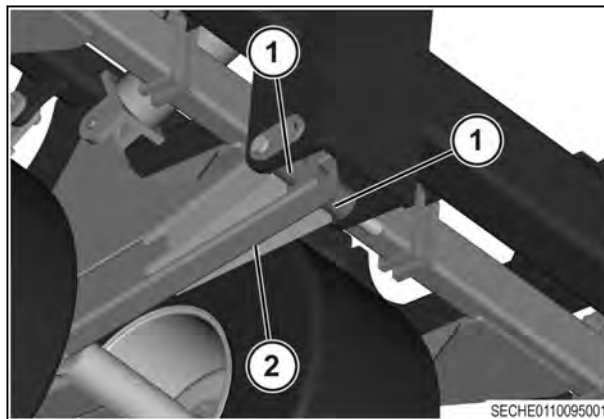

Fig. 2

### Rear hitch pivots

Find one grease fitting (1) in each of the rear hitch pivot pins (2).

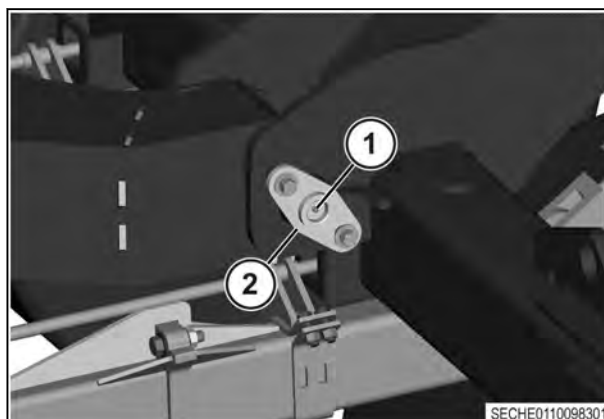

Fig. 3

**Fertilizer bander strut pivot**

Find the grease fitting (1) for each fertilizer bander strut pivot (2) in front of the pivot.

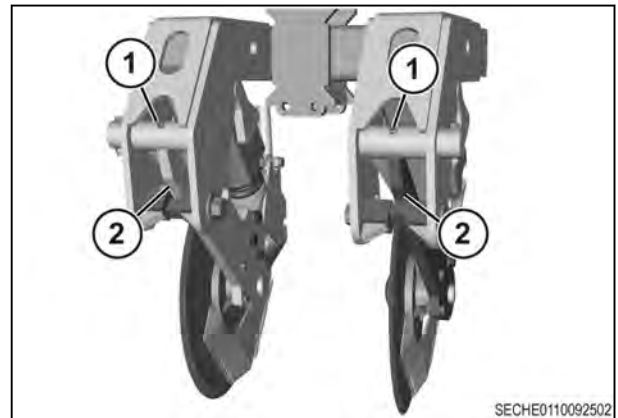

Fig. 4

**Hydraulic lift assist tie rod**

Find the grease fittings (1) for the tie rod (2) on the hydraulic lift assist hitch at each end of the tie rod.

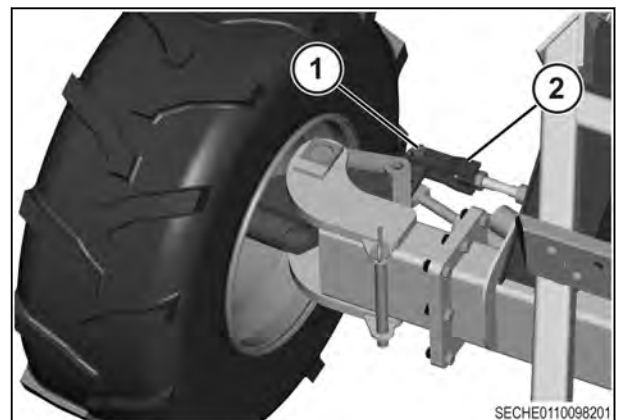

Fig. 5

**Hydraulic lift assist king pin**

Find the grease fittings (1) for each of the king pins in the hydraulic lift assist hitch on top of each king pin (2).

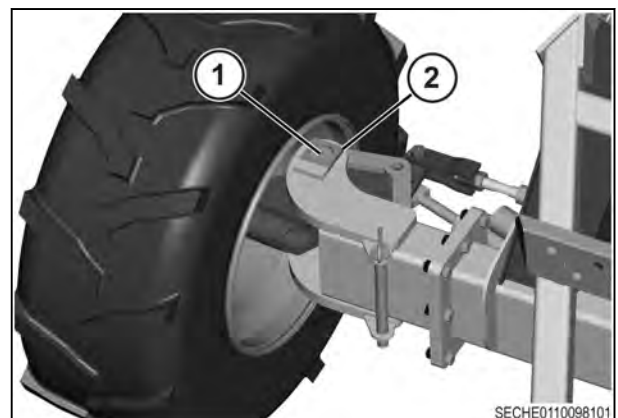

Fig. 6

### Wing frame hinge point

Find the grease fittings (1) for each wing frame pivot on the center frame (2) side of the pivot.

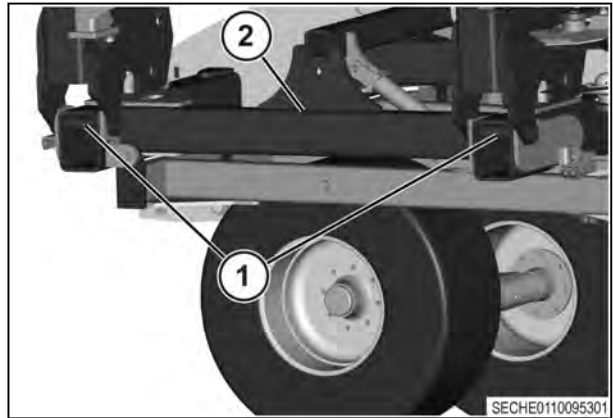

Fig. 7

### Wing fold links and pivot

**NOTE:** *On the five-section frames only.*

Find the grease fittings (1) for the wing fold links on the bottom pivot of each wing fold link.

Find the grease fittings (2) for the wing fold pivots in each pivot pin.

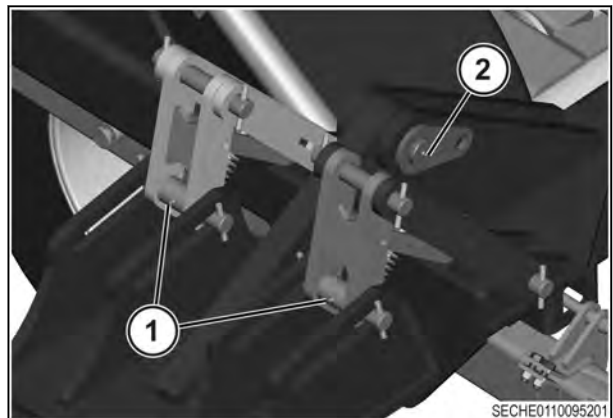

Fig. 8

### Packing wheel and disc hubs

Each packing wheel and disc hub has one grease fitting.

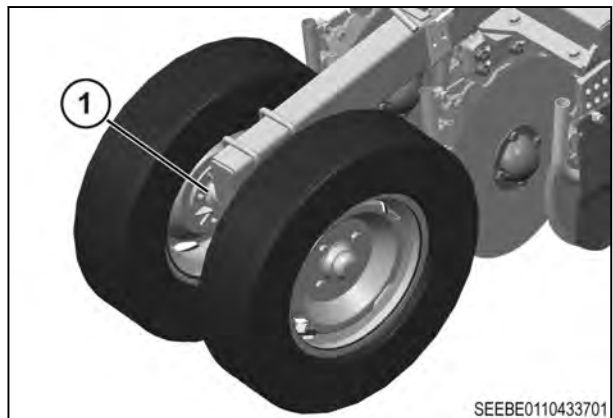

Fig. 9

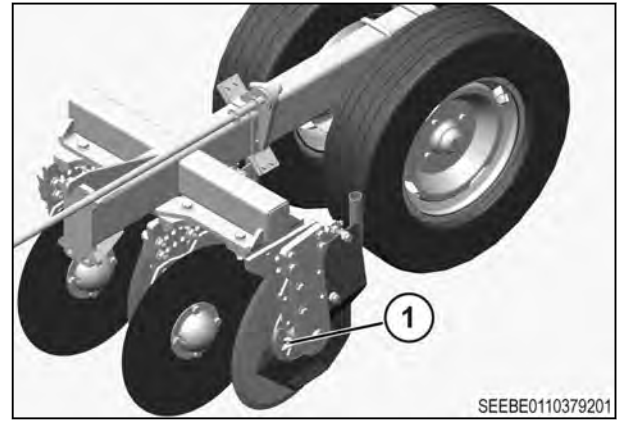

Fig. 10

SEEBE0110379201

### 4.3 Leveling the drill frames

Use the following procedure to adjust the left to right level of the drill frames.

#### Procedure

1. Connect the drill to a tractor of the correct size to operate the drill.
2. Park the drill on a flat and level surface. Apply the tractor park brake.
3. Lift the drill to the highest position and then hold the hydraulic lever in the raised position for five seconds.
4. With the drill frame lifted, measure the distance (A) from the ground to the bottom of the frame (1). Measure in front of each of the frame and the wing support cylinders (2).

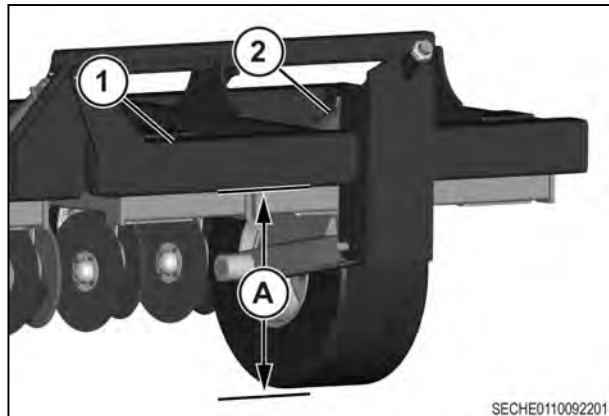

Fig. 11

5. Adjust the adjusting rods (1) above each of the wing support cylinders (2). Adjust the adjusting rod until the measurement between the frame and the ground is the same. Adjust the adjusting rods by tightening or loosening the jam nut (3) on either end of the adjusting rod.
6. Make sure the measurement at each of the wing support cylinders is equal. Tighten the jam nuts against the tube that holds the adjustment rod.

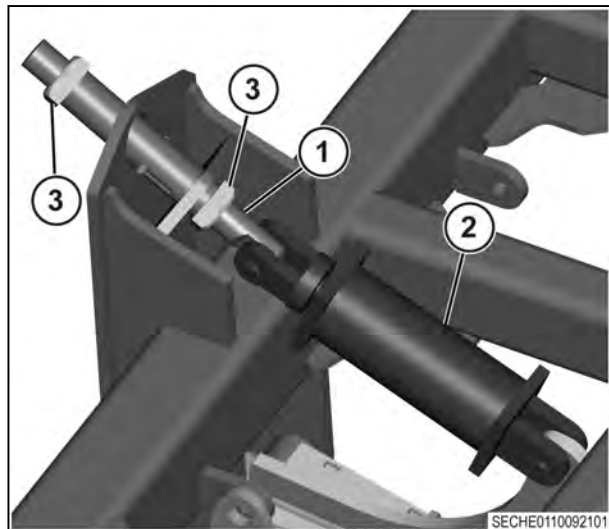

Fig. 12

## 4.4 Opening disc scraper adjustment

The opening disc scraper (1) is adjusted correctly when the full length of the front edge (2) of the disc scraper lightly touches the opening disc (3). Adjust the opening disc scraper with the two nuts (4) fastening the disc scraper to the opener assembly.

**NOTE:** *The opening disc scraper and opening discs are painted from the factory. The paint must wear off before the disc scraper and disc will operate correctly.*

Adjust the opening disc scrapers according to field conditions and the wear of the disc scraper.

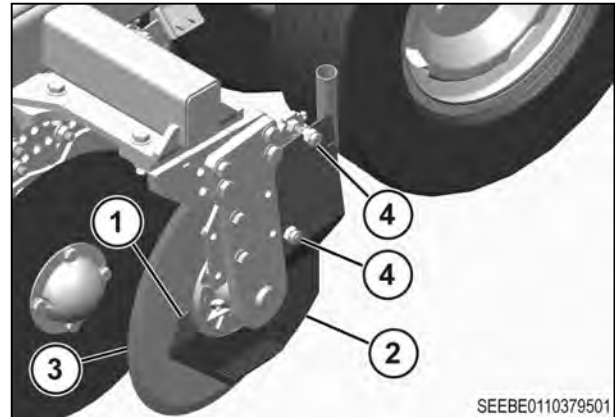

Fig. 13

### 4.4.1 Adjusting the opening disc scraper

#### Procedure

1. Loosen the jam nuts (1) on the top and bottom adjusting nuts.
2. Tighten the bottom adjusting nut (2) until the full length of the front edge (3) of the opening disc scraper lightly touches the opening disc (4). Keep the position of the opening disc scraper in the middle of the groove in the top adjusting nut (5). Keep the position by tightening or loosening the top adjusting nut.
3. Tighten the top adjusting nut until the bottom (6) of the opening disc scraper lifts off of the opening disc.
4. Loosen the top adjusting nut until the bottom of the front edge of the opening disc scraper lightly touches the opening disc.
5. Tighten the jam nuts on the top and bottom adjusting nuts.

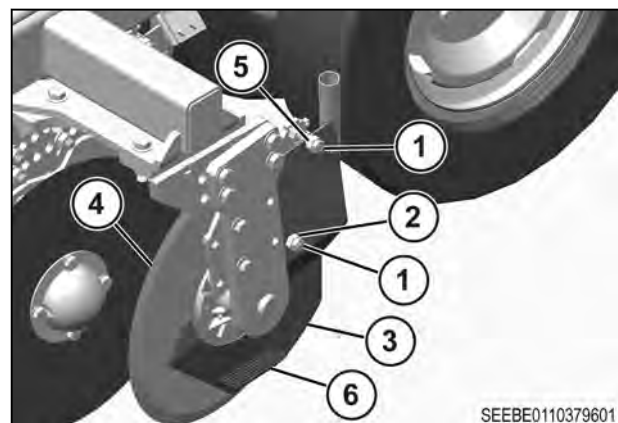

Fig. 14

#### After finishing the procedure

Adjust the opening disc scrapers on the remaining opening disc assemblies.

## 4.5 Opening disc offset

The opening disc offset is the amount of offset (A) between the two opening discs (1) on each toolbar. The opening disc offset prevents material from accumulating between the two opening discs on the opening disc assembly.

The opening disc offset is set at 114 mm (4.5 inch) at the factory, but can be adjusted from 38 mm (1.5 inch) to 165 mm (6.5 inch).

Increase the opening disc offset for wet, sticky soils.

Decrease the opening disc offset for dry, sandy soils.

If operating in soil with large rocks, set the opening disc offset to the maximum offset.

If opening disc offset is too wide, there will not be enough soil movement for sufficient soil compaction.

If opening disc offset is too narrow, material will build between the two opening discs.

Use the five sets of holes on one side (1) of the opener mount to adjust one of the opening discs. Use the two sets of holes on the opposite side (2) to adjust the other opening disc offset. Each set of holes will change the offset by 25 mm (1 inch) (A).

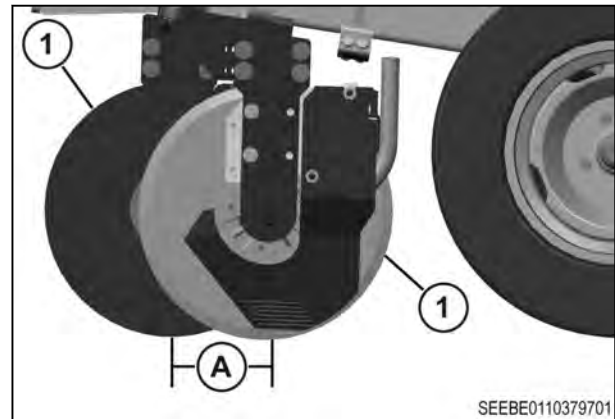

Fig. 15

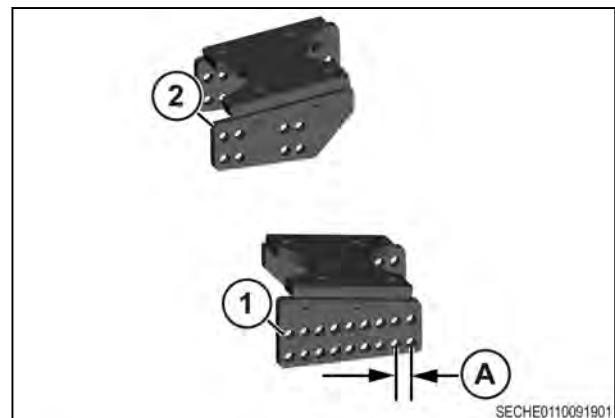

Fig. 16

### Opening disc offset table

The following table shows the opening disc offset according to the position of the opening disc struts (1) on the opening disc mount (2). The first column shows the number of pairs of holes (3) forward of the opening disc strut on the five position side of the opener mount. The second column shows the position of the opening disc strut on the two position side of the opener mount, forward or rear. The third column shows the opening disc offset.

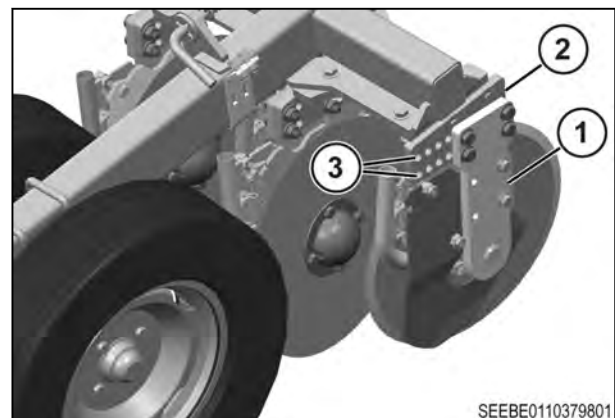

Fig. 17



Number of Pairs of Holes Forward of the Opening Disc Strut	Position of the Opening Disc Strut	Opening Disc Offset
0	Rear	165.1 mm (6.5 inch)
0	Forward	139.7 mm (5.5 inch)
1	Forward	114.3 mm (4.5 inch)
2	Forward	88.9 mm (3.5 inch)
3	Forward	63.5 mm (2.5 inch)
4	Forward	38.1 mm (1.5 inch)

### 4.5.1 Setting opening disc offset

The opening disc offset is adjusted according to field conditions.

#### Procedure

1. Lift the frame of the implement to the highest position.
2. Stop the tractor. Stop the engine, apply the tractor park brake, and take the ignition key with you.
3. Support the opening disc strut (1) and opening disc (2).
4. Remove and keep the four bolts, washers, and lock nuts attaching the opening disc strut to the opener mount (3).
5. Move the opening disc strut to the new position of the opener mount.
6. Attach the opening disc strut to the opener mount with the existing bolts, washers, and lock nuts.

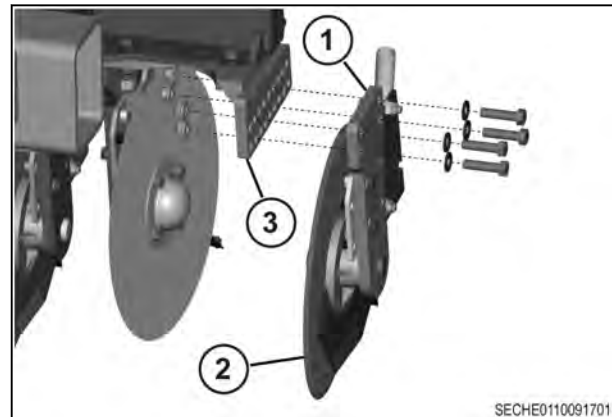

Fig. 18

#### After finishing the procedure

Move the remaining opening disc struts to the new position on the opener mounts on the remaining opening disc assemblies.

## 4.6 Frame height cylinder phasing

When the support cylinders extend to the same length at the same time the support cylinders are in phase. If the cylinders do not extend to the same length at the same time then the cylinders must be put in phase.

Frame height cylinders that are out of phase will cause the machine to not be level with the ground when lifting or lowering the machine. A frame that is not level to the ground will cause different seed depth between each toolbar.

---

### 4.6.1 Putting the frame height cylinders in phase

---

#### **Before starting the procedure**

To put the frame height cylinders in phase the machine must be connected to the correct size of tractor to operate the machine.

Putting the frame height cylinders in phase makes sure the cylinders are moving to the same length at the same time.

#### **Procedure**

1. Lift the frame of the machine to the highest position.
2. Hold the hydraulic lever in the raised position for five seconds.

#### **After finishing the procedure**

Make sure the frame height cylinders are phased by lowering the machine to the ground and raising the machine to half of the fully raised height. If the frame is level to the ground then the cylinders are in phase.

## 4.7 Bleeding air from the hydraulic system

### Before starting the procedure

To bleed the air from the hydraulic system the machine must be connected to a tractor that is the correct size to operate the machine.

When air has entered the hydraulic system through a leak or from repair the hydraulic system must be completely bled of air.

### Procedure

1. Lift the frame of the machine to the highest position.
2. Hold the hydraulic lever in the raised position for several minutes.
3. Lower the frame of the machine to the lowest position or to the ground.
4. Again, lift the frame to the highest position and then hold the lever in the raised position for several minutes.

### Result of the procedure

Repeat the lifting and lowering of the frame until all of the air has been bled from the hydraulic system.

## 4.8 Storage

### 4.8.1 Preparing the drill for storage

Complete the following steps to prepare the drill for storage at the end of the season.

#### Procedure

1. Park the drill on a level surface, away from other machinery.
2. Use the tractor hydraulics to lower the wing frames of the drill to the ground.
3. Stop the engine, apply the tractor park brake, and take the ignition key with you.
4. Remove and keep the roll pins (1), the washers (2), and pins (3) holding the wing-side of the wing lift cylinders (4) to the wing frame (5).
5. Start the tractor. Use the tractor hydraulics to retract the wing lift cylinders all the way.
6. Stop the engine, apply the tractor park brake, and take the ignition key with you.
7. Install the existing pins in the wing-side of the wing lift cylinders.
8. Use the front hitch jack to support the front hitch of the drill.
9. Disconnect the tractor from the drill.
10. Apply grease to the surfaces of the cylinder rods that are still showing.

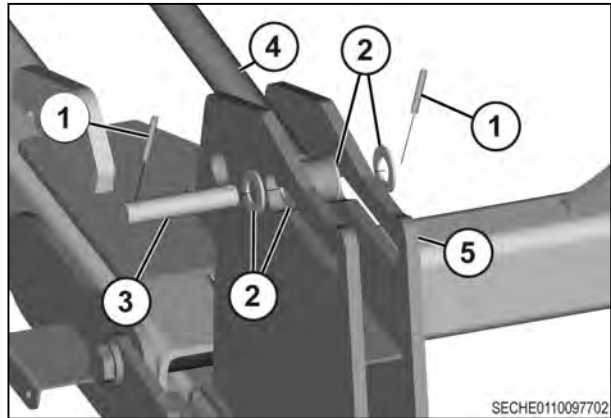

Fig. 19

### 4.8.2 Removing the drill from storage

Complete the following steps to remove the drill from storage at the beginning of the season.

#### Procedure

1. Connect the drill to the tractor.
2. Stop the engine, apply the tractor park brake, and take the ignition key with you.
3. Remove and keep the roll pins, washers, and pins used to attach the wing side of the wing cylinder.
4. Place the wing lift cylinders so damage does not occur to the cylinders when extending.
5. Start the tractor. Use the tractor hydraulics to extend the wing lift cylinders. Extend the cylinders until the end of the wing lift cylinders align with the mount on the wing frame.
6. Stop the engine, apply the tractor park brake, and take the ignition key with you.
7. Install the wing side of the wing lift cylinders (1) to the mount (2) on the wing frames. Use the existing roll pins (3), the washers (4), and pins (5) to attach the wing lift cylinders.
8. Lubricate the components of the drill.
9. Check the tire pressures of all the tires on the drill.
10. Inspect all the hydraulic hoses and the connections for leaks and repair as necessary.
11. Make sure all the adjustments on the drill are within the specified range.

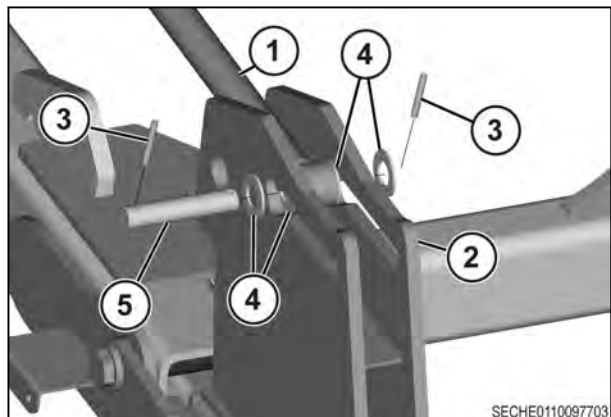

Fig. 20

- 12.** Make sure the safety signs are visible and not damaged.
- 13.** Make sure all marker lamps operate correctly.



## 5. Specifications

<b>5.1 Specifications</b> .....	97
<b>5.2 Maximum transport speed</b> .....	99
<b>5.3 Frame and rear hitch tire air pressure</b> .....	100





## 5.1 Specifications

Size	Sections	Power requirements	Base weight
9.14 m (30 ft)	3	157 to 194 kW (210 to 260 hp)	9 616 kg (21 200 lbs)
12.19 m (40 ft)	3	187 to 239 kW (250 to 320 hp)	12 020 kg (26 500 lbs)
15.24 m (50 ft)	5	224 to 269 kW (300 to 360 hp)	17 690 kg (39 000 lbs)
18.28 m (60 ft)	5	283 to 373 kW (380 to 500 hp)	19 958 kg (44 000 lbs)

Size	Seed openers	Fertilizer openers	Weight with fertilizer banders	Ballast kit weight
9.14 m (30 ft)	48	24	11 113 kg (24 500 lbs)	581 kg (1 280 lbs)
12.19 m (40 ft)	64	32	14 060 kg (31 000 lbs)	735 kg (1 620 lbs)
15.24 m (50 ft)	80	40	20 400 kg (45 000 lbs)	1 007 kg (2 220 lbs)
18.28 m (60 ft)	96	48	23 133 kg (51 000 lbs)	1 315 kg (2 900 lbs)

Size	Transport width	Transport Height	Transport clearance
9.14 m (30 ft)	4.3 m (14.25 ft)	4.42 to 4.72 m (14 to 15.5 ft)	0 to 50.8 cm (20 in)
12.19 m (40 ft)	5.8 m (18.92 ft)	5.13 to 5.44 m (16 to 17.84 ft)	0 to 50.8 cm (20 in)
15.24 m (50 ft)	6.6 m (21.5 ft)	4.11 to 4.67 m (13.5 to 15.34 ft)	0 to 50.8 cm (20 in)
18.28 m (60 ft)	6.6 m (21.5 ft)	5.13 to 5.43 m (16 to 17.83 ft)	0 to 50.8 cm (20 in)

Tire sizes	
Main frame support tires	440/55R18 158A8
Wing frame support tires	36 x 17.5 8 ply
Hydraulic lift assist tires	23.5L/55-26
Floating rear hitch tire	12.5L-15 8 ply

Toolbar specifications	
Disc size	18
Seed depth	0 to 7.6 cm (0 to 3 in)
Row spacing	15 to 23 cm (6 to 9 in) pair row

Towing capacities - drawbar weight	
Floating hitch	454 kg (1 000 lbs)
Hydraulic lift assist hitch	4 535 kg (10 000 lbs)

Towing capacities - (GTW)	
Floating hitch	13 600 kg (30 000 lbs)
Hydraulic lift assist hitch	27 200 kg (60 000 lbs)

## 5.2 Maximum transport speed

Machine	Maximum transport speed
Three-section frames	32 kph (20 mph)
Five-section frames	24 kph (15 mph)

### 5.3 Frame and rear hitch tire air pressure

Tire	Three-section Frame	Five-section Frame
Main Frame Support Tires	503 kPa (73 psi)	503 kPa (73 psi)
Wing Frame Support Tires	276 kPa (40 psi)	276 kPa (40 psi)
Hydraulic Lift Assist Hitch Tires	276 kPa (40 psi)	
Floating Hitch Tires	248 kPa (36 psi)	Not Available

## 6. Accessories

<b>6.1 Fertilizer bander attachment</b> .....	103
6.1.1 Adjusting fertilizer bander depth .....	103



## 6.1 Fertilizer bander attachment

The optional fertilizer bander attachment (1) applies anhydrous ammonia or fertilizer between the two furrows that are made by the opening disc assemblies. The fertilizer bander attachment is installed forward of the opening disc assemblies.

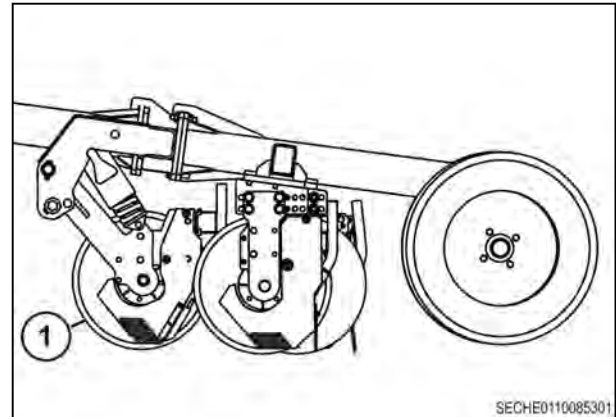

Fig. 1

The depth at which the fertilizer bander applies the fertilizer is set using a cam block (1). The slots (2) in the cam block determine the depth of the fertilizer. The deeper the slot in the cam block; the deeper the fertilizer is applied.

**IMPORTANT:** *When operating in rocky soil conditions, do not operate at a high rate of speed. High speeds in rocky conditions will damage the fertilizer bander attachment.*

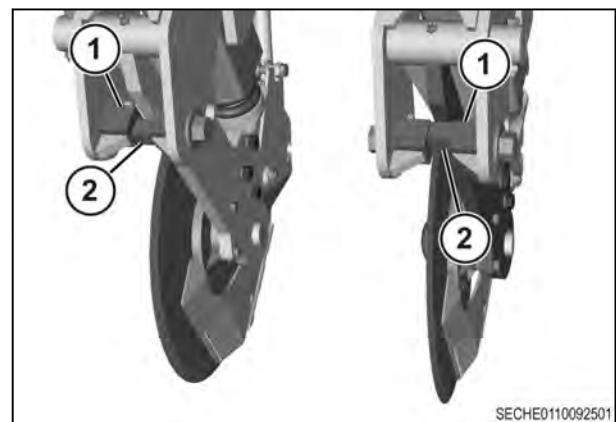

Fig. 2

### 6.1.1 Adjusting fertilizer bander depth

#### Before starting the procedure

To adjust the fertilizer bander depth the machine must be connected to the correct size of tractor to operate the machine.

#### Procedure

1. Raise the frame of the machine until the bander discs are off of the ground.
2. Stop the tractor. Stop the engine, apply the tractor park brake, and take the ignition key with you.
3. Place a wooden block below one of the discs (1) on the fertilizer bander attachment that is to be adjusted.
4. Start the tractor and lower the machine to the ground.
5. Stop the tractor. Stop the engine, apply the tractor park brake, and take the ignition key with you.

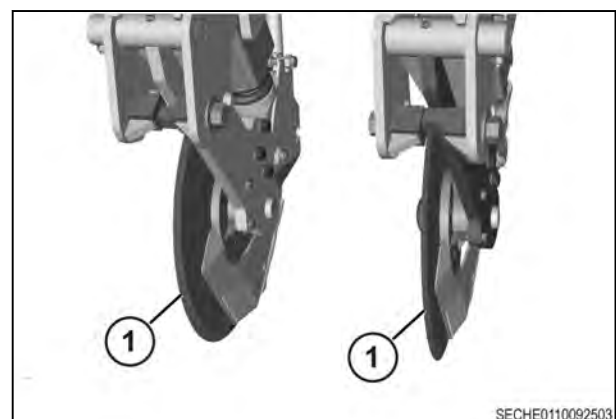

Fig. 3

6.



**CAUTION:**  
**Make sure the fertilizer bander disc is firmly supported by the wooden block. If the fertilizer bander disc is not firmly supported then start the tractor, raise the machine, and reposition the wooden block.**

Remove the bolt (1) and washer (2) securing one end of the cam block (3) for the bander disc (4) being supported by the wooden block.

7. Slide the cam block out of the bander frame.
8. Install the cam block in the bander frame so the desired depth groove in the cam block will contact the bander disc strut.
9. Secure the cam block in the bander frame using the existing bolt and washer.
10. Start the tractor and raise the machine until the bander disc is off of the wooden block.
11. Stop the tractor. Stop the engine, apply the tractor park brake, and take the ignition key with you.
12. Remove the wooden block from below the bander discs.

#### After finishing the procedure

Use the same procedure to adjust the remaining bander disc on the fertilizer bander attachment and the other bander attachments.

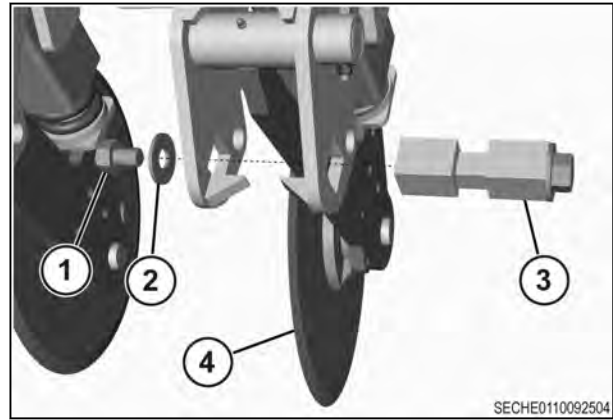

Fig. 4



## 7. Assembly

<b>7.1 Preparing for assembly</b> .....	107
<b>7.2 Assembling the main frame</b> .....	108
7.2.1 Assembling the wings to the main frame .....	108
7.2.2 Assembling the wing extensions to the wing frames .....	109
7.2.3 Assembling the one hub lift wheel .....	113
7.2.4 Assembling the two hub lift wheel .....	115
7.2.5 Installing the lift wheel assembly to the main frame .....	120
7.2.6 Installing the lift wheel assembly to the wing frame and wing extension .....	122
<b>7.3 Installing the toolbars</b> .....	124
7.3.1 Unpacking the toolbars .....	124
7.3.2 Installing and assembling the outer toolbars .....	127
7.3.3 Installing the assembled toolbars .....	133
<b>7.4 Installing the front pull hitch</b> .....	137
<b>7.5 Installing the frame height control hydraulics</b> .....	141
<b>7.6 Installing the work switch sensor</b> .....	149
<b>7.7 Installing the floating rear hitch</b> .....	151
7.7.1 Installing the down pressure hydraulics on the floating rear hitch .....	151
7.7.2 Installing the wing lift hydraulics on the floating rear hitch .....	157
7.7.3 Installing the floating hitch frame to the main frame .....	160
7.7.4 Installing the floating rear hitch wheel assembly .....	161
7.7.5 Installing the bulkhead on the floating rear hitch .....	162
7.7.6 Installing the rear hitch on the floating rear hitch .....	165
7.7.7 Installing the rolling mount flow divider on the floating rear hitch .....	165
7.7.8 Installing the down pressure harness on the floating rear hitch .....	166
7.7.9 Installing the marker lamps and harness on the floating rear hitch .....	167
7.7.10 Installing the main ISO harness on the floating rear hitch .....	174
<b>7.8 Installing the hydraulic lift assist</b> .....	175
7.8.1 Installing the down pressure hydraulics on the hydraulic lift assist .....	175
7.8.2 Installing the wing lift hydraulics on the hydraulic lift assist .....	183
7.8.3 Installing the hydraulic lift assist frame to the main frame .....	188
7.8.4 Assembling the hydraulic lift assist rear axle .....	189
7.8.5 Installing the hydraulic lift assist .....	192
7.8.6 Installing the bulkhead on the hydraulic lift assist .....	196
7.8.7 Installing the rear hitch on the hydraulic lift assist .....	198
7.8.8 Installing the hydraulic caster lock .....	199
7.8.9 Installing the rolling mount flow divider on the hydraulic lift assist .....	200
7.8.10 Installing the down pressure harness on the hydraulic lift assist .....	202
7.8.11 Installing the marker lamps and harness on the hydraulic lift assist .....	202
7.8.12 Installing the main ISO harness on the hydraulic lift assist .....	208
<b>7.9 Installing the secondary flow dividers</b> .....	210
<b>7.10 Installing the dual flow dividers</b> .....	211
7.10.1 Installing the dual hitch mounted flow dividers .....	211
<b>7.11 Installing the wireless blockage monitor system</b> .....	212
7.11.1 Installing the wireless blockage monitor .....	212
7.11.2 Installing the blockage sensors .....	213
7.11.3 Installing the wireless blockage monitor harness .....	215
<b>7.12 Installing the seed delivery system</b> .....	217
7.12.1 Assembling the seed tower manifold .....	217
7.12.2 Installing the 2 zone seed towers .....	218

7.12.3	Installing the 4 zone seed towers . . . . .	221
7.12.4	Routing the seed delivery hoses . . . . .	224
7.12.5	Installing the seed delivery hoses . . . . .	227
<b>7.13</b>	<b>Installing the fertilizer bander . . . . .</b>	<b>228</b>
7.13.1	Installing the fertilizer bander assembly . . . . .	228
7.13.2	Assembling the fertilizer bander with the dry tube . . . . .	228
7.13.3	Assembling the fertilizer bander with the NH3 injector and the dry tube . . . . .	228
<b>7.14</b>	<b>Installing the soybean toolbar . . . . .</b>	<b>229</b>
<b>7.15</b>	<b>Installing safety and information signs . . . . .</b>	<b>230</b>
7.15.1	Installing safety signs . . . . .	230
7.15.2	Installing information signs . . . . .	230

## 7.1 Preparing for assembly

Read this section carefully before assembly. Refer to the Parts Book for additional component breakdowns while assembling the machine.

It is important that all of the nuts and bolts be used in the locations in which they are assigned. This will prevent damage to the machine.

**IMPORTANT:** *When two or more bolts are being used on a part, always insert the bolts and loosely tighten the nuts. Once the correct placement has been achieved, tighten the nuts evenly to prevent misalignment or distortion of the parts. Tighten U-bolt nuts to the same torque for proper alignment.*

Select a large, flat, and hard surface for assembly of machine. The machine will require a minimum of 14 m (43 ft ) by 12 m ( 39 ft ) of open space for proper assembly.

**IMPORTANT:** *Keep all parts in the assigned containers until the parts are to be used.*

**NOTE:** *Some items will be assembled at the factory*

Large parts are packaged on pallets or in racks.

Smaller weldments and parts are in crates. Inside each crate are boxes and bags assigned to that specific crate.

## 7.2 Assembling the main frame

### 7.2.1 Assembling the wings to the main frame

1. Install the two 1-1/2 x 11 bolts (1) through the wing section and the main frame section.

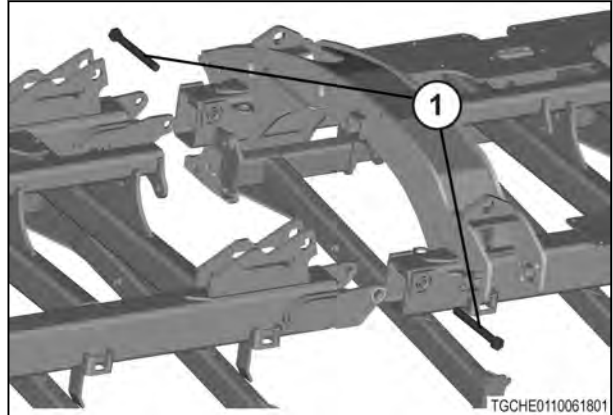

Fig. 1

2. Install the bolt and set in the socket cavity (1) as shown.

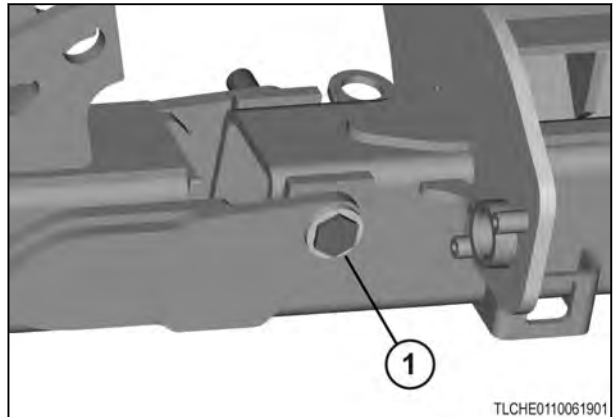

Fig. 2

3. Install and tighten the 1-1/2 jam nut (1).



Fig. 3

4. Install and tighten the second 1-1/2 jam nut (1) against the first jam nut.

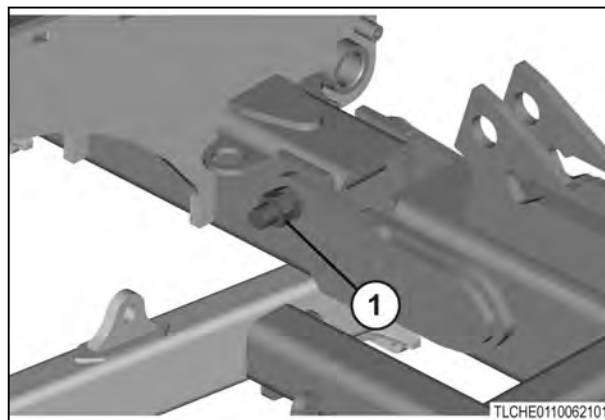

Fig. 4

5. Place two 5500kg(6 ton) stands (1) under the wing and remove the lifting straps.

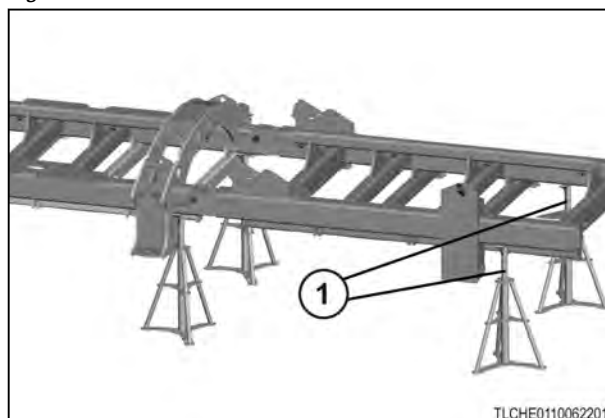

Fig. 5

### 7.2.2 Assembling the wing extensions to the wing frames

1. Install the 1-1/4 x 7 bolt (1) through the wing extension and the wing frame.

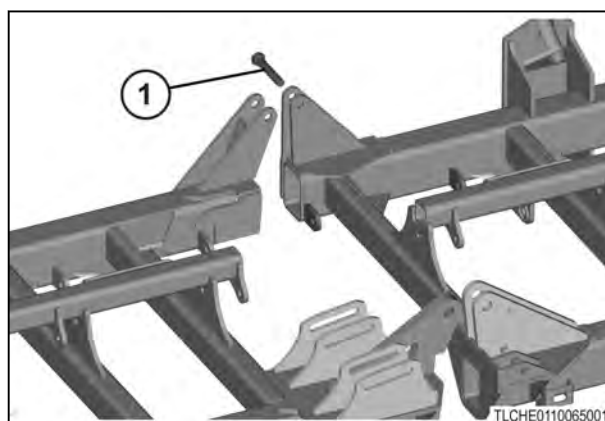

Fig. 6

2. Install the first 1-1/4 jam nut (1).

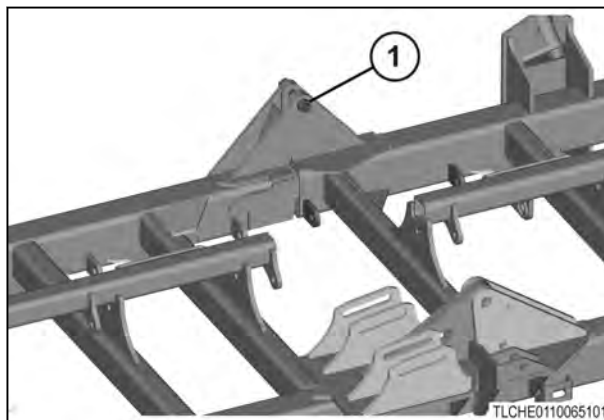

Fig. 7

3. Install the second 1-1/4 jam nut (1) against the first jam nut.

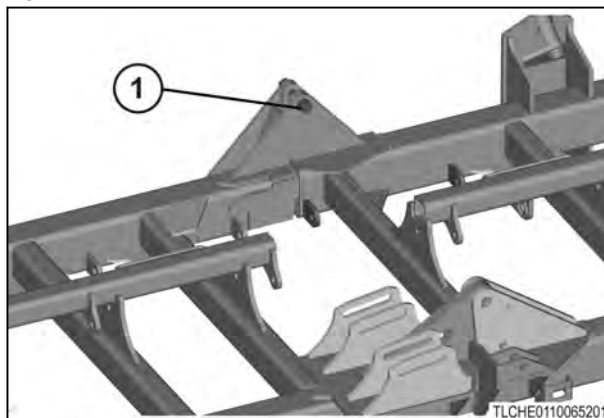

Fig. 8

4. Insert the metal spacer (1) into the channel .

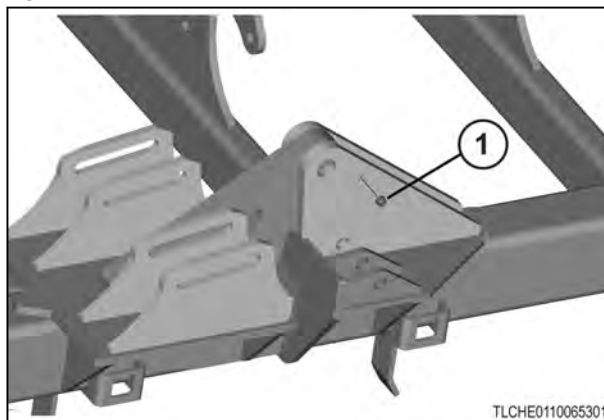

Fig. 9

5. Install the 1-1/2 x 8 flag pin (1) through the wing frame and the wing frame extension.
6. Install the 1-1/2 nylon lock nut (2) on the flag pin (1).

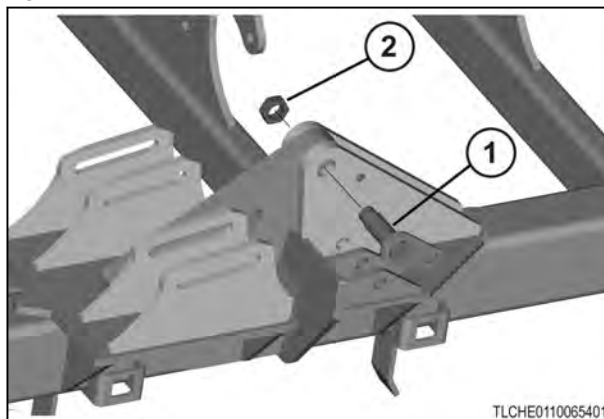

Fig. 10

7. Align the flag pin with the hole, install the 5/8 washer (2) and 5/8 x 2-1/2 bolt (1).
8. Install the 5/8 lock nut (3) on the bolt (1).

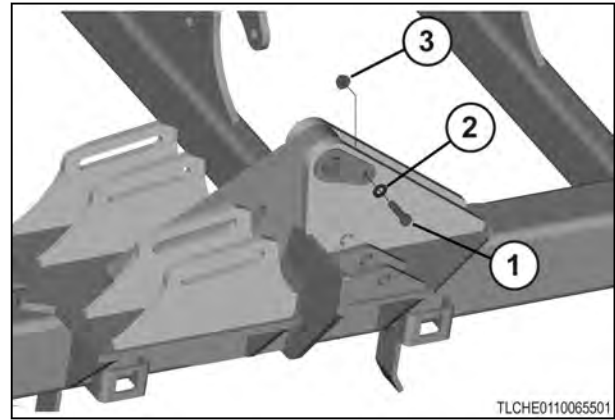

Fig. 11

9. Align the spring arm (2) with the outer link (3) and insert the kicker pivot pin (1).

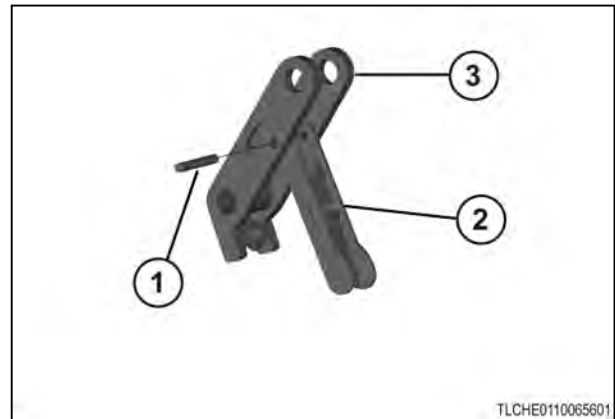

Fig. 12

10. Install the two 1/2 C-clips (1) on the installed kicker pivot pin.



Fig. 13

11. Install the 1/2 x 3/4 bolt (1) through the 1/2 washer (2), the outer link, the 1/2 spring (3), the spring arm. Install the 1/2 washer (4) and the 1/2 lock nut (5).

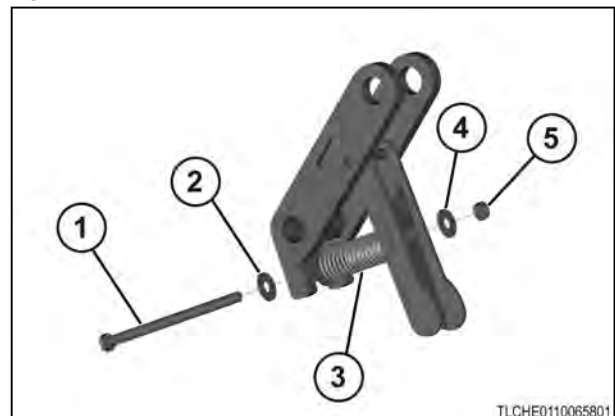

Fig. 14

- Align the inner link (1) with the outer link and insert the 1-1/4 x 7-1/2 pin (2).

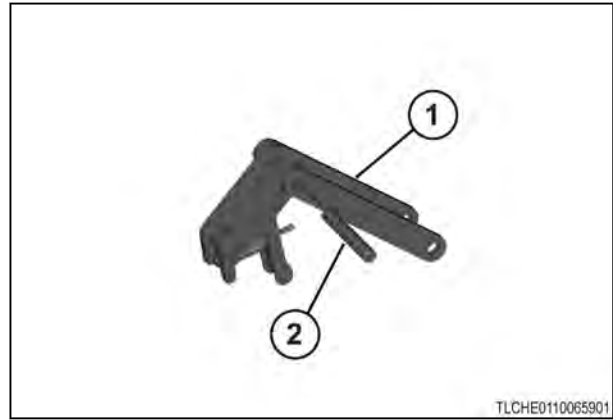

Fig. 15

- Install the two 3/8 x 3 roll pins (1).

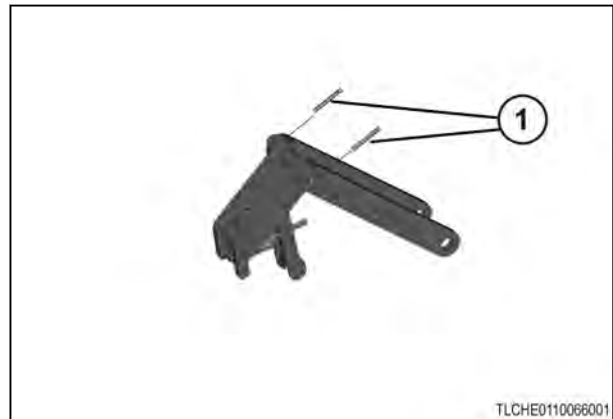

Fig. 16

- Align the linkage assembly (1) with the wing frame and the wing extension frame. Install the two 1-1/4 x 7-1/2 linkage pins (2).

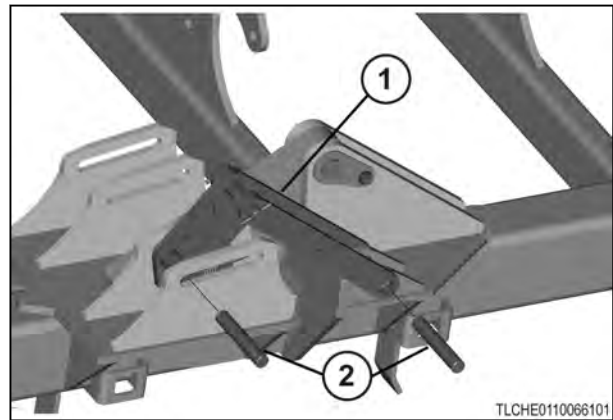

Fig. 17

- Install the four 3/8 x 3 roll pins (1).

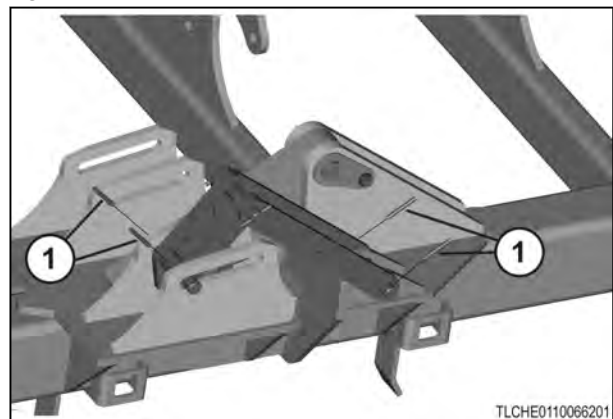

Fig. 18



16. Install the inner linkage assembly (2) on the frame.

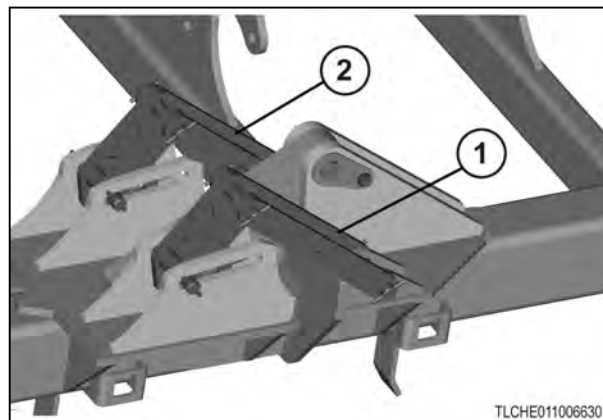

Fig. 19

17. Place two 5500kg(6 ton) stands (1) under the wing extension frame, and remove lifting straps.

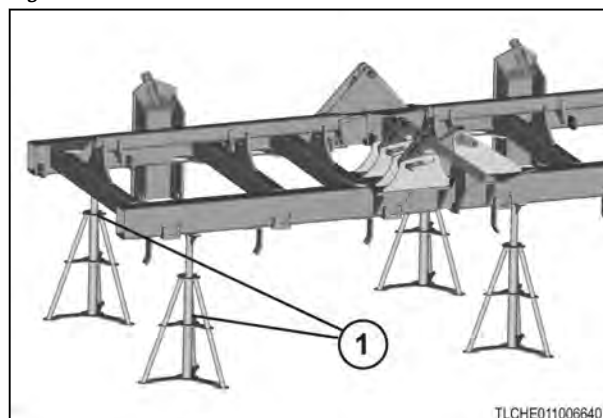

Fig. 20

### 7.2.3 Assembling the one hub lift wheel

1. Place the outer wing strut (1) on stands or a work bench. The outer wing strut has two extended shaft tubes (2) and no pivot limiter.

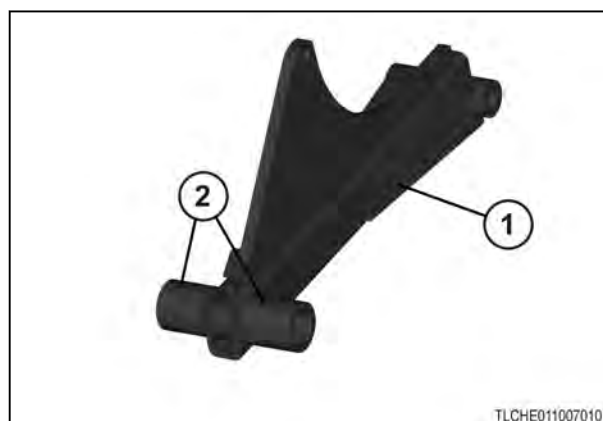

Fig. 21

2. Install the two grease fittings (1) on the front of the outer wing strut.

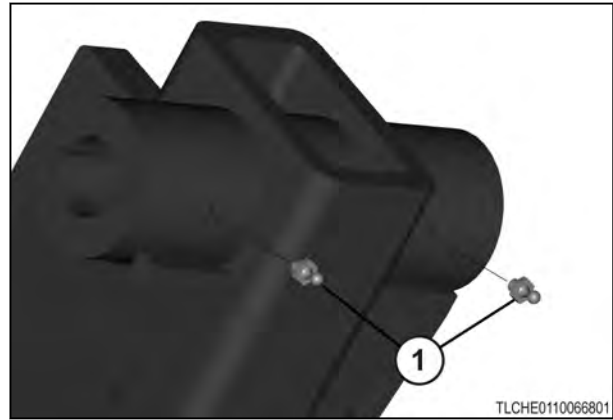

Fig. 22

3. Install the hub and spindle assembly (1) in the shaft tube (2). Align the holes (3).

**NOTE:**

*The right-hand and left-hand outer lift wheels require different outer wing struts. With the strut oriented with the machine, the vertical plate will be on the left-hand side of the left-hand strut and right-hand side of the right-hand strut.*



Fig. 23

4. Install the 5/8 x 5-1/2 bolt (1) and 5/8 lock nut (2) through the shaft tube and the spindle.



Fig. 24

5. Install the 8 ply tire (1) on the hub (2).

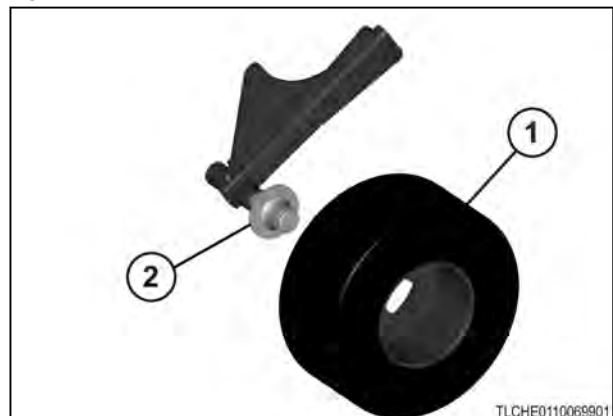

Fig. 25

6. Install the eight lug nuts (1) on the lug bolts. Tighten the nuts to 300 to 340 Nm (226 to 254 lbf ft).

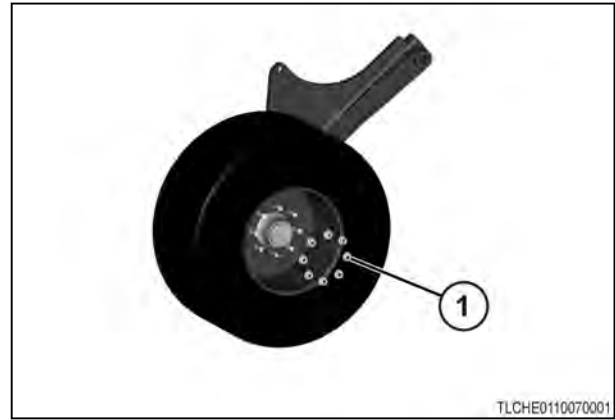

Fig. 26

### 7.2.4 Assembling the two hub lift wheel

1. Put the left main strut weldment (1) on stands or a work bench.

**NOTE:** To identify left-hand or right-hand struts, locate pivot limiter (3) on the rear of the strut weldment. The shaft mounting hole (2) is on the right-hand side of the left-hand strut weldment. The shaft mounting hole is on the left side of the right-hand strut weldment.



Fig. 27

2. Install the two grease fittings (1) on front of the main strut weldment.

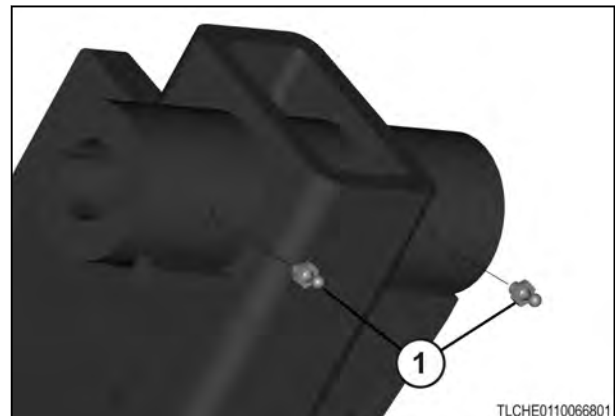

Fig. 28

3. Install the walking beam shaft (1) in the main strut weldment and align the holes (2).

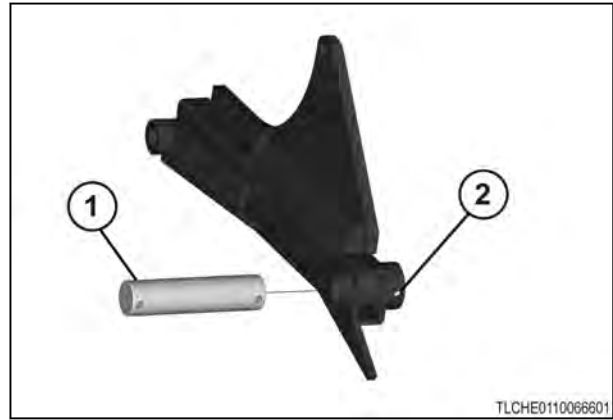

Fig. 29

4. Install the 5/8 x 4 1/2 bolt (1) and the 5/8 lock nut (2).

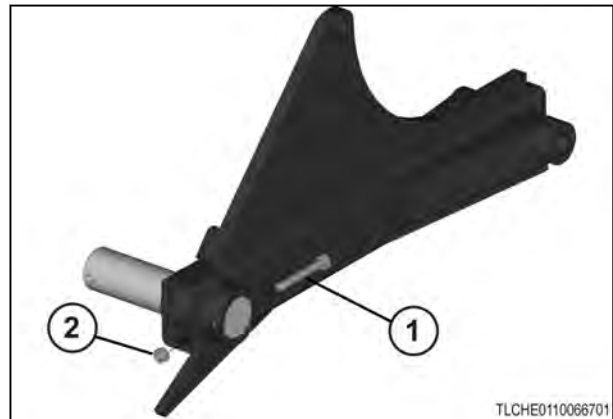

Fig. 30

5. Find a walking beam weldment (1) and put the walking weldment on a work bench. Install the two grease fittings (2).

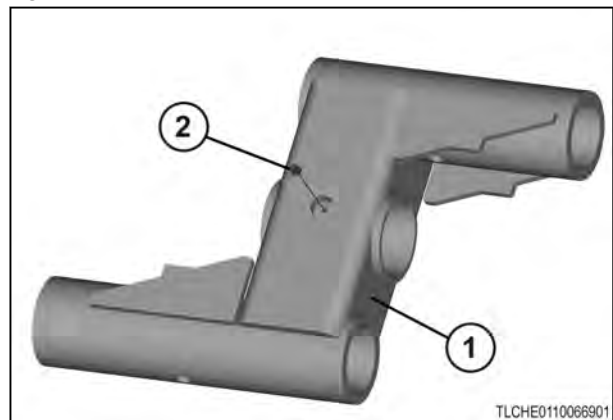

Fig. 31

6. Install the walking beam spacer (2) into the walking beam. Align the holes (3) so grease can flow to the walking beam shaft.
7. Install the two 3-1/2 OD x 3 ID x 2 1/2 split bushings (1).

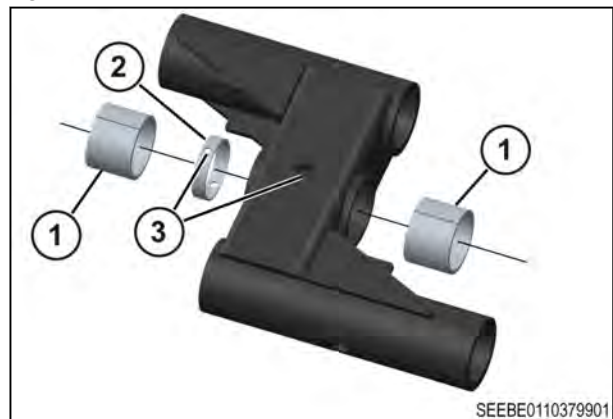

Fig. 32

8. Align the bushings flush (1) with the walking beam weldment on both sides.

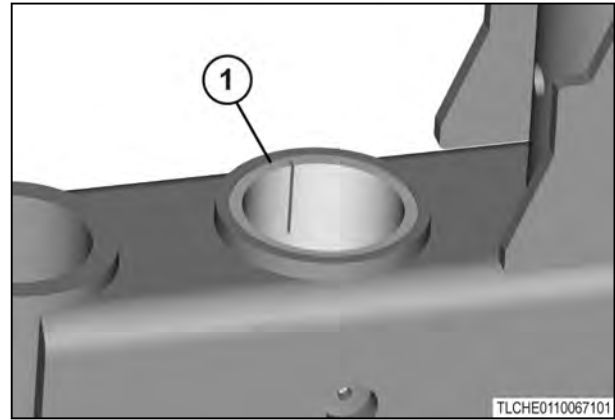

Fig. 33

9. Install the walking beam (1) and the collar (2) on the walking beam shaft.

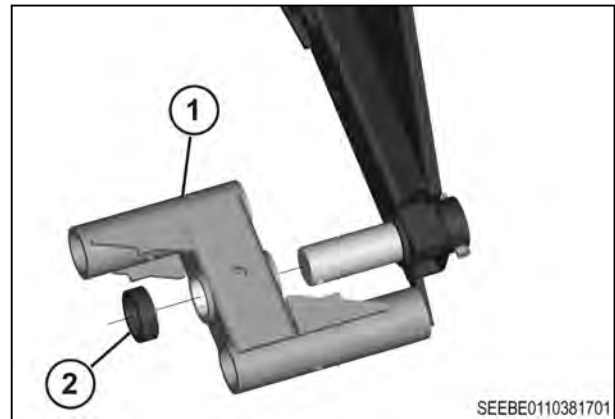

Fig. 34

10. Install the 5/8 x 4 1/2 bolt (1) and the 5/8 lock nut (2).

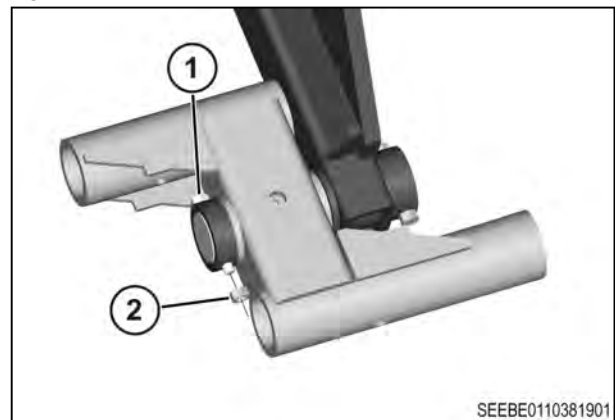

Fig. 35

11. Install the hub and spindle assembly (1) in the tube of the walking beam. Align the holes (2).

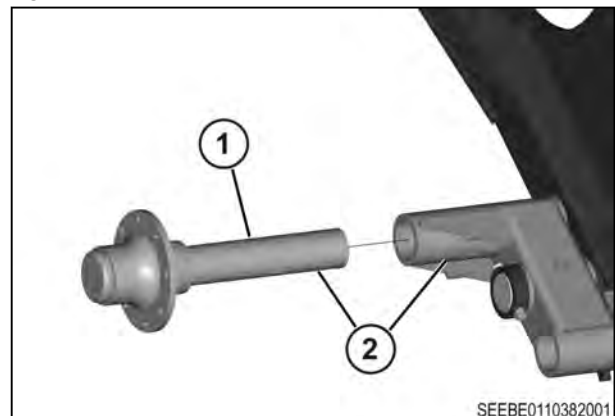

Fig. 36

- 12.** Install the 5/8 x 4 1/2 bolt (1) and the 5/8 lock nut (2) through the walking beam tube and the spindle.

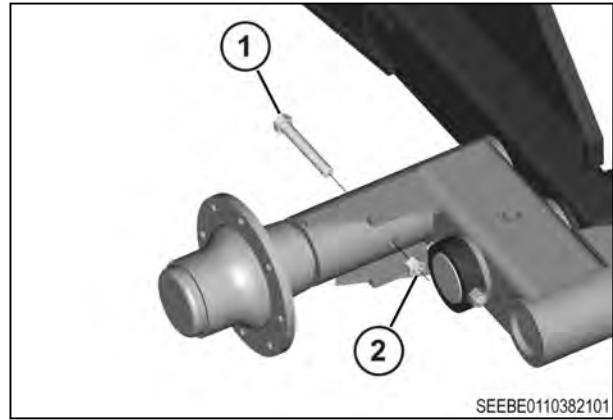

Fig. 37

- 13.** Install the 8 ply tire (1) on the hub (2).  
The 8 ply tires are only used on the wings.

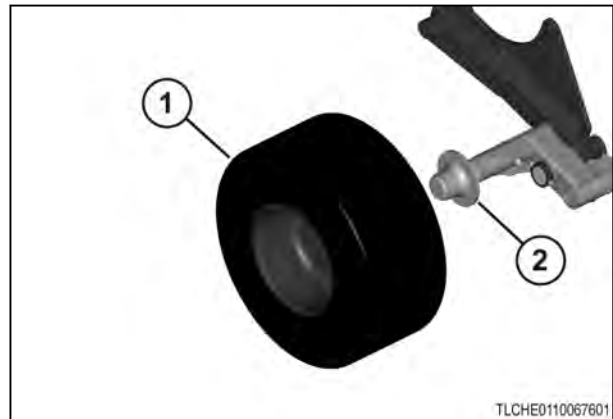

Fig. 38

- 14.** Install the eight lug nuts (1) on the lug bolts. Tighten the lug nuts (1) to 300 to 340 Nm (226 to 254 lbf-ft) .

**NOTE:** *The main frame lift wheels require 5/8 jam nuts on the lug bolts. Tighten jam nuts to 130 Nm (95 lbf-ft) .*

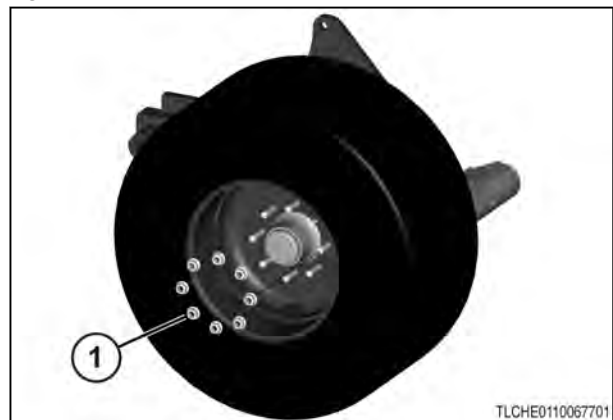

Fig. 39

- 15.** Place a stand (1) under the lift wheel assembly and lower the main strut (2) to the ground.

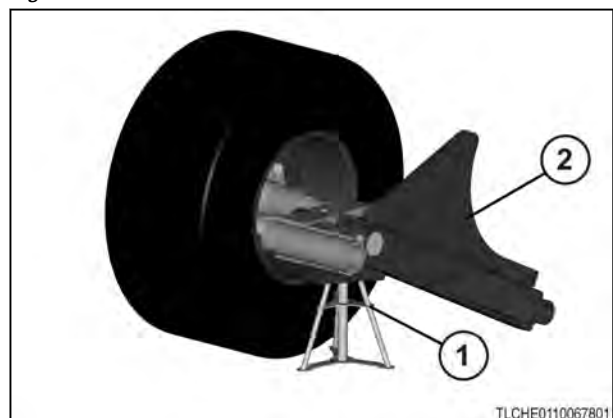

Fig. 40

16. Install the hub and spindle assembly (1) in the tube of the walking beam. Align the holes (2).

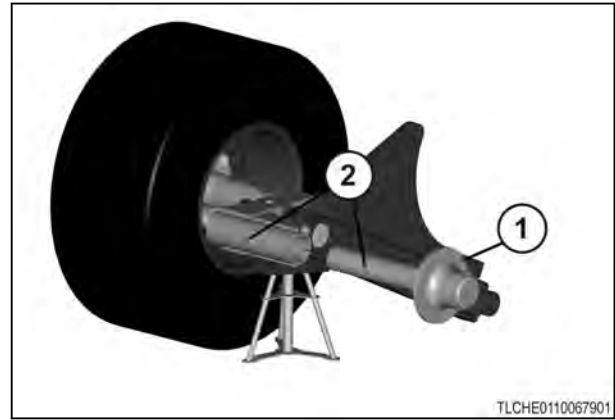

Fig. 41

17. Install the 5/8 x 4 1/2 bolt (1) through the tube of the walking beam and the spindle. Install the 5/8 lock nut (2).

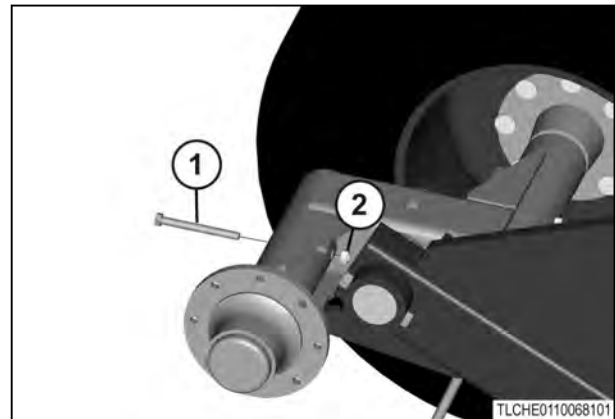

Fig. 42

18. Install the 8 ply tire (1) on the hub (2).

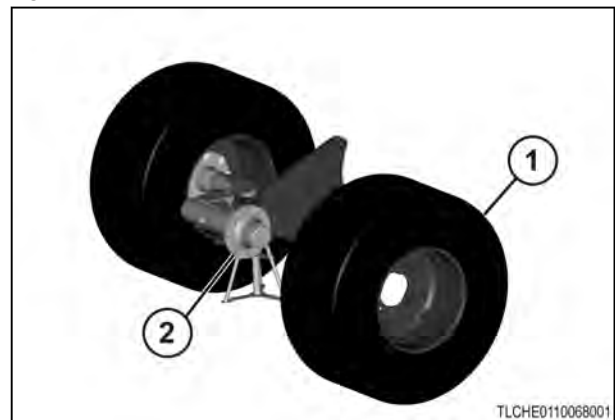

Fig. 43

19. Install the eight lug nuts (1) on the lug bolts. Tighten the lug nuts (1) to 130 Nm (95 lbf-ft).
20. Remove the jack and the set assembly aside for later installation. Repeat steps to assemble all two hub lift wheel assemblies.

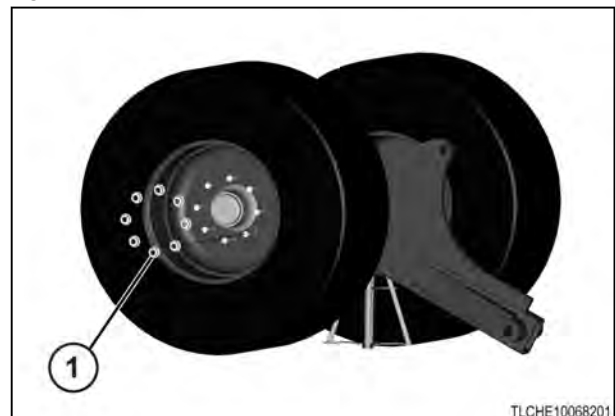
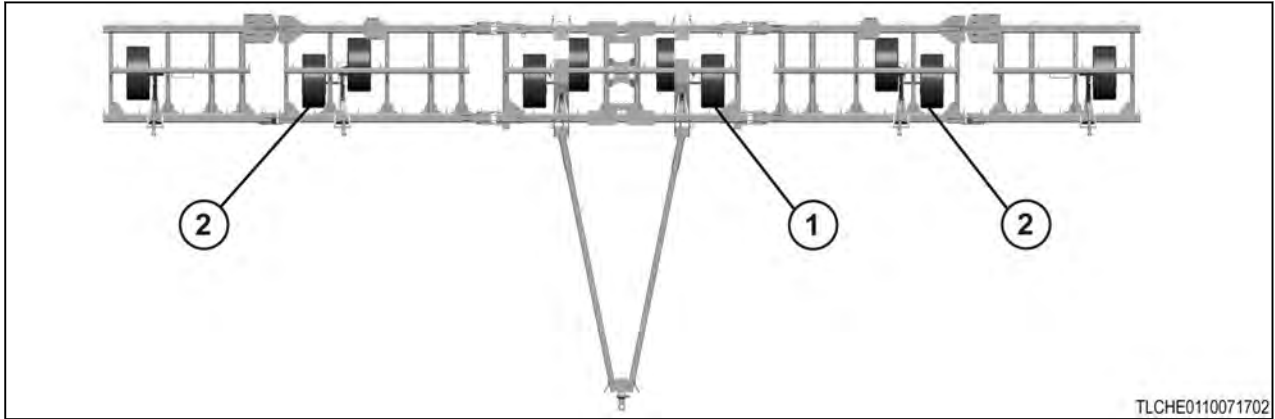

Fig. 44

## 7.2.5 Installing the lift wheel assembly to the main frame



TLCHE0110071702

Fig. 45

1. To install the correct lift wheel assembly the left-hand or right-hand wheel will be the forward wheel (1) toward the outer end of frame.

**NOTE:** The 60ft frame is shown, layout of lift wheels is similar for all other frame widths. On 50 ft models, the wheel assembly (2) is opposite of what is shown.

2. Place a left hand wheel assembly (1) under the left hand main frame wheel mount (2).

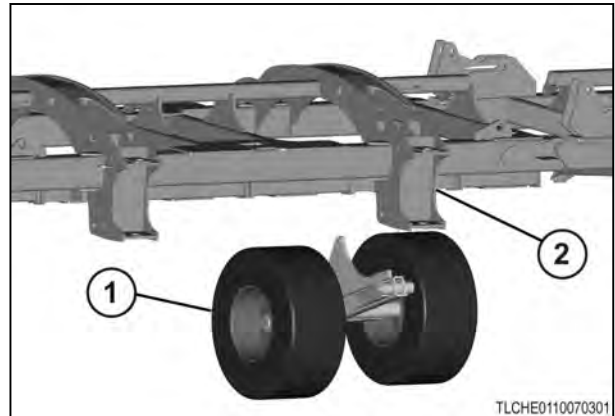

TLCHE0110070301

Fig. 46

3. Install the 14 x 1-1/2 flag pin (1) with the flag bracket towards the inside of the main frame section. Install and hand tighten the two 1-1/2 jam nuts (2) (3).

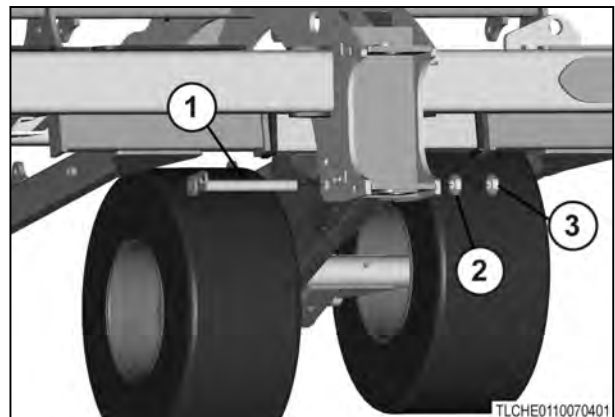

TLCHE0110070401

Fig. 47



4. Install the 1/2 x 1 bolt (1), 1/2 lock washer (2), and the 1/2 flat washer through the flag bracket.

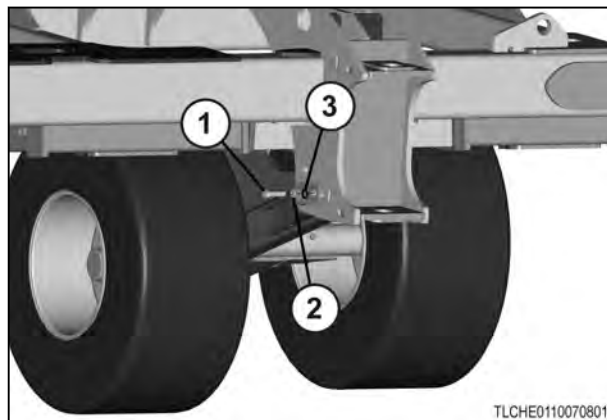

Fig. 48

5. Tighten the first 1-1/2 jam nut (1) on the flag pin.

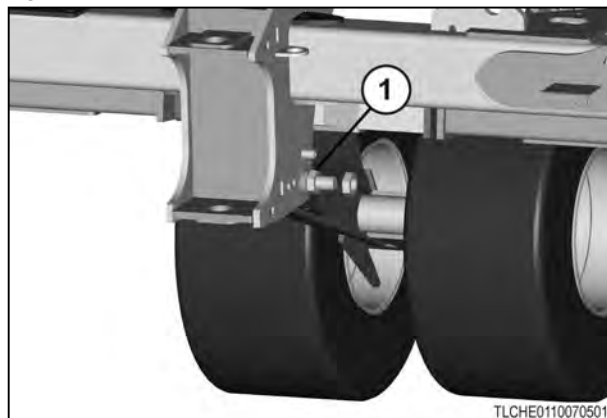

Fig. 49

6. Tighten the second 1-1/2 jam nut (1) against the first jam nut.

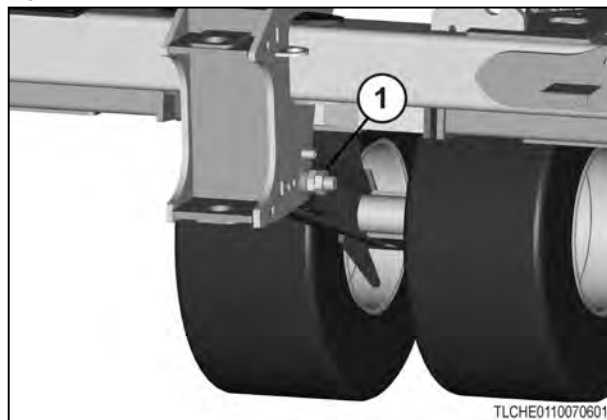

Fig. 50

## 7.2.6 Installing the lift wheel assembly to the wing frame and wing extension

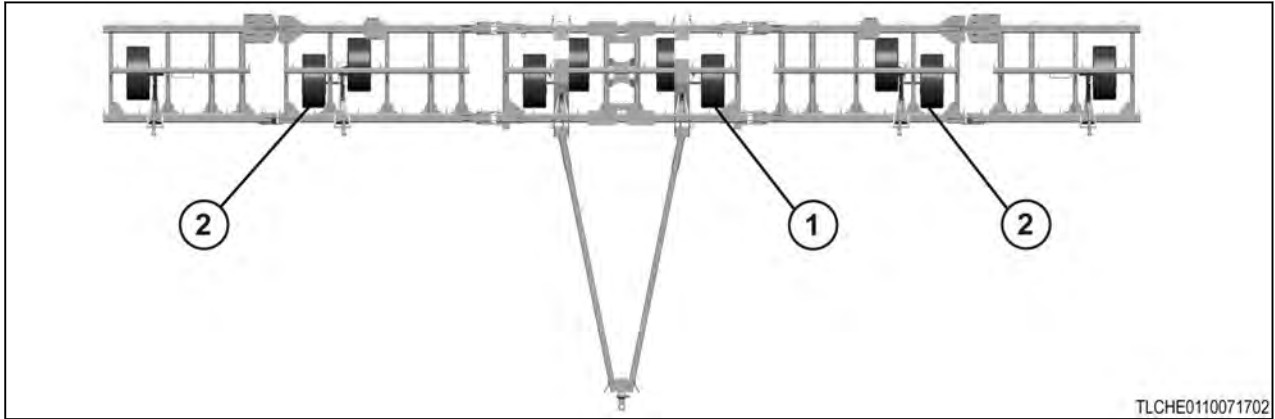

Fig. 51

1. To install the correct lift wheel assembly the left-hand or right-hand wheel will be the forward wheel (1) toward the outer end of frame.

**NOTE:** The 60ft frame is shown, layout of lift wheels similar for all other frame widths. On 50 ft models, the wheel assembly (2) is opposite of what is shown.

2. Install lift wheel assembly (1) under wing wheel mount (2).

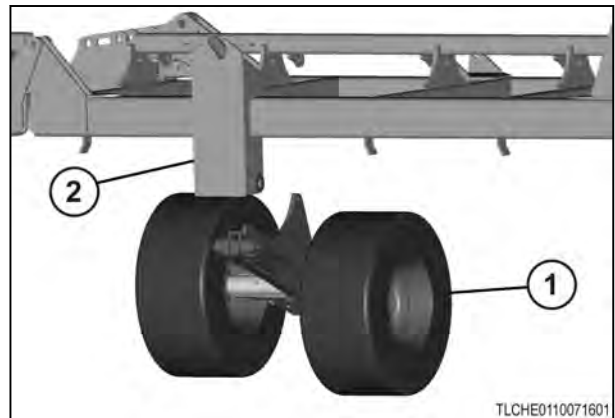

Fig. 52

3. Install the 1-1/2 x 12-1/2 bolt (1) and the 1-1/2 jam nuts (2) (3), through the wing wheel mount and the lift wheel strut.

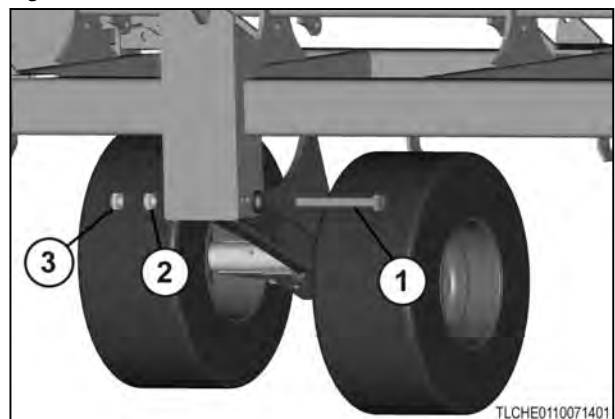

Fig. 53

4. Install the 1-1/2 x 12-1/2 bolt with the head of the bolt (1) set in the socket cavity (2).

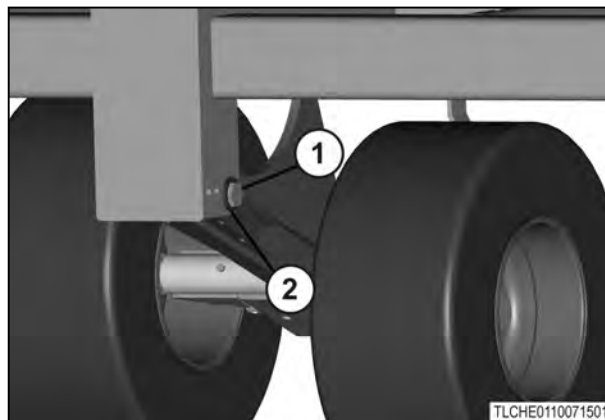

Fig. 54

5. Install the first 1-1/2 jam nut (1).

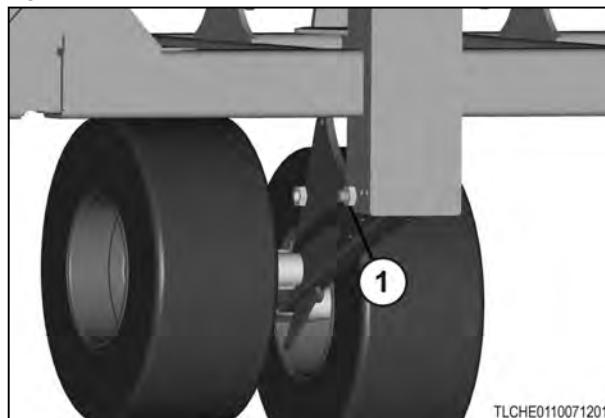

Fig. 55

6. Install the second 1-1/2 jam nut (1) and tighten against the first jam nut.

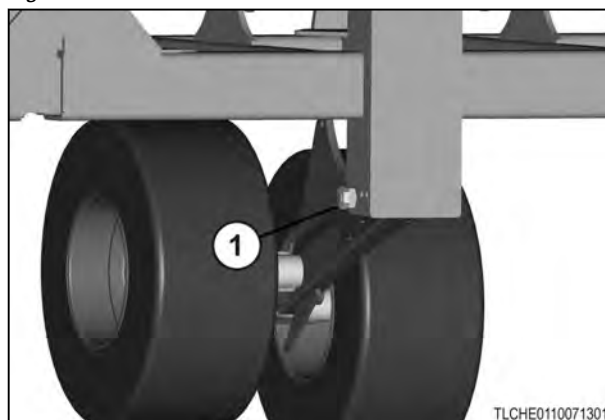

Fig. 56

## 7.3 Installing the toolbars

### 7.3.1 Unpacking the toolbars

#### Procedure

1. Find the empty toolbar frame that is perpendicular to the rest of the toolbars on the rack.
2. Install a lifting strap (1) as illustrated on the empty toolbar frame.

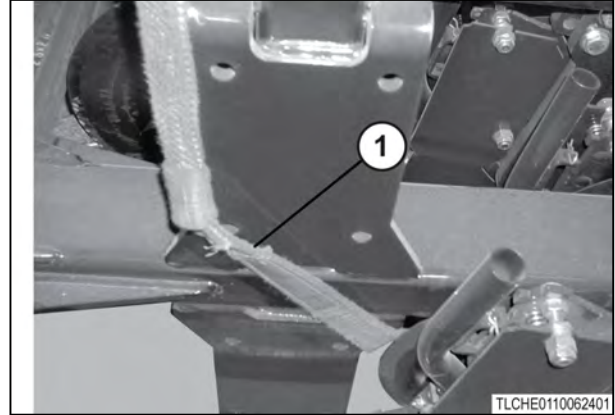

Fig. 57

3. Remove the two retaining bolts (1) and nuts.

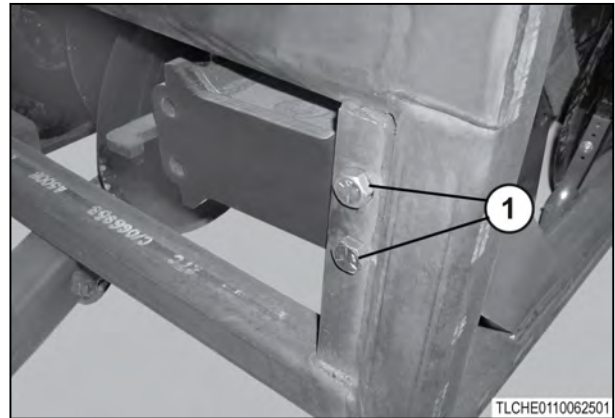

Fig. 58

4. Move the toolbar frame (1) clear of the shipping rack.

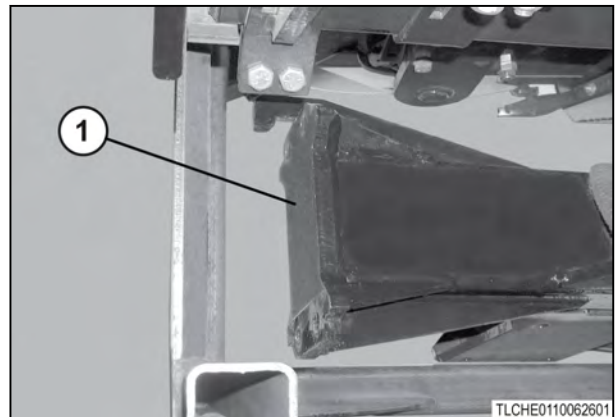

Fig. 59

5. Carefully lift the toolbar frame up and away from the shipping rack and set aside for a later installation.

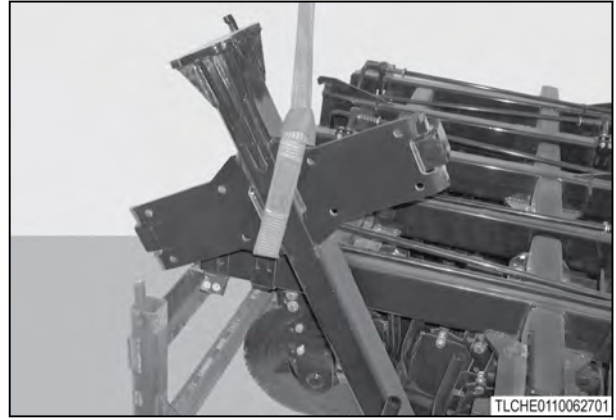

Fig. 60

6. Find the empty toolbar frame with two toolbar lock rod assemblies installed.

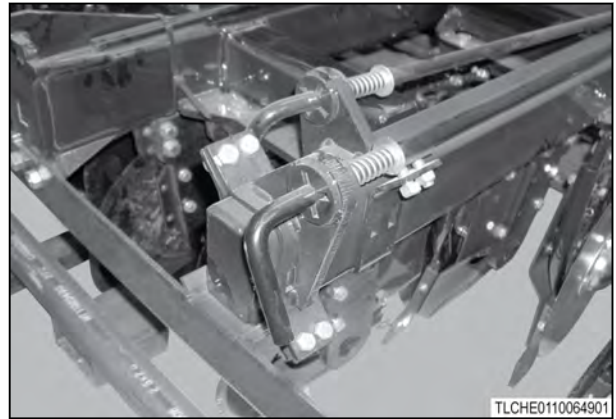

Fig. 61

7. Remove 1/2 x 1-1/2 bolts (1). Remove the extra toolbar lock rod assembly (2) and set aside for a later installation.

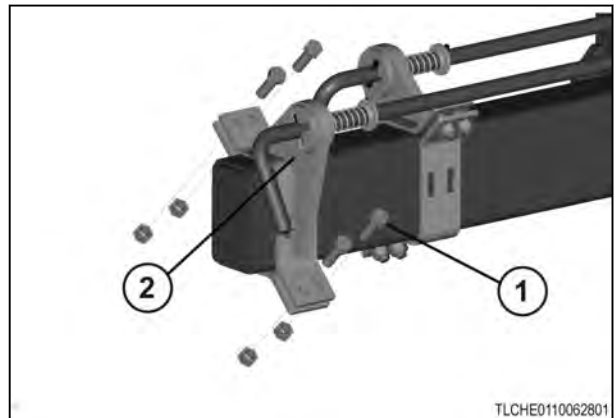

Fig. 62

8. Install lifting straps (1) as illustrated on empty toolbar frame with toolbar lock rod assembly.

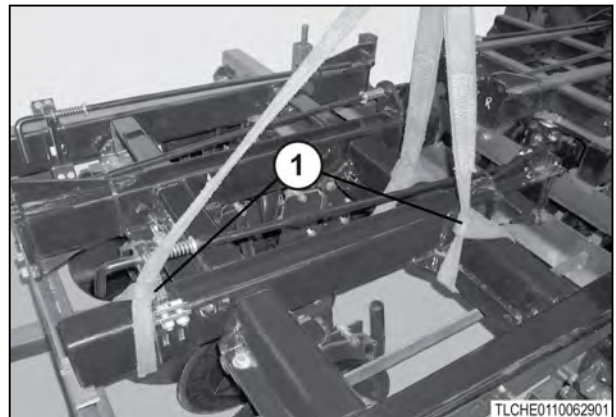

Fig. 63

9. Remove the two retaining bolts and nuts (1).

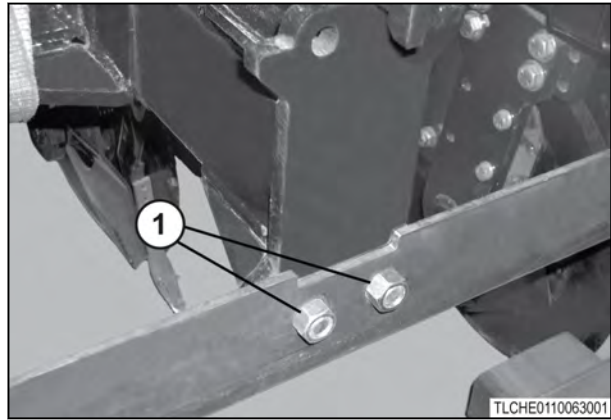

Fig. 64

10. Lift the toolbar frame from the shipping rack and set aside for a later installation.



Fig. 65

11. Install lifting straps (1) as illustrated when removing the remaining toolbars from the shipping racks. The toolbars will remain balanced and level when removed with the lifting straps in place as illustrated.

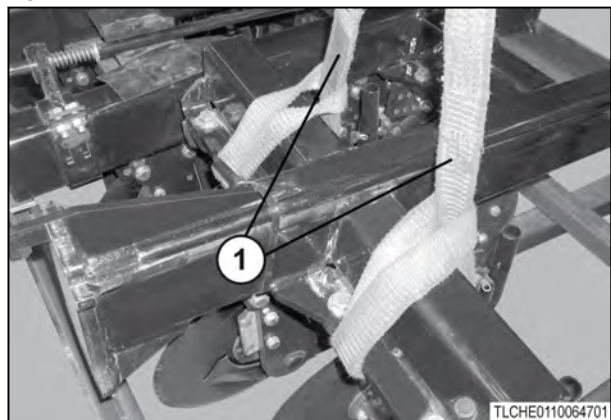

Fig. 66

12. Removing two retaining bolts (1) and nuts.

**NOTE:** The left-hand toolbars will be identified with a "L" mark, and the right-hand toolbars will be identified with a "R" mark. If "L" or "R" are unreadable or missing, the opener disc on the left side will be forward on a left-hand toolbar and the opener disc will be forward on the right-hand toolbar.

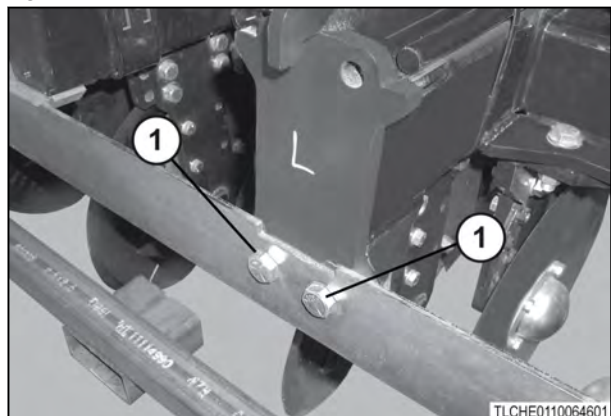

Fig. 67



13. Lift the toolbar clear of the shipping rack.

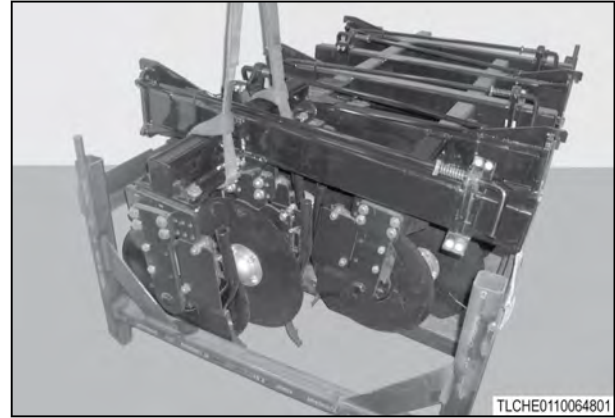

Fig. 68

### 7.3.2 Installing and assembling the outer toolbars

1. Install the toolbar frame without the toolbar lock assembly (3) to the outer left-hand toolbar (4). Install the four 5/8 x 2-1/2 fine thread bolts (1), the eight 5/8 flat washers (2), and the four 5/8 nuts (5). Tighten the bolts (1) and nuts (5) to 170Nm (125lb-ft).

**NOTE:** The outer right-hand toolbar frame will have toolbar lock pre-installed.

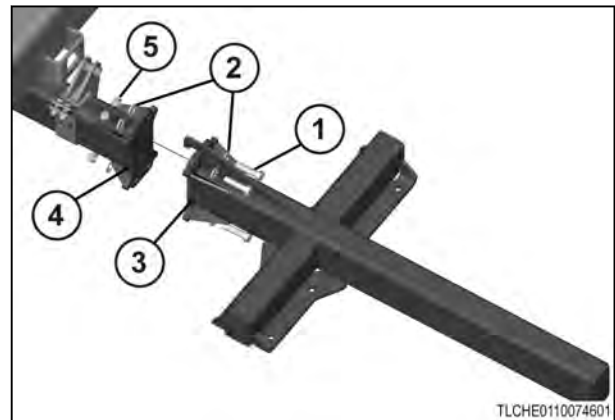

Fig. 69

2. Remove the opener mounts from the shipping bundle. Determine the left-hand (1) mounts and the right-hand (2) mounts.

**NOTE:** The front of the opener mounts are angled (3).

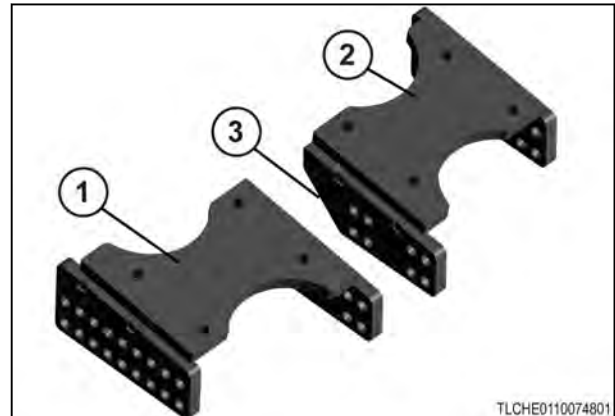

Fig. 70

3. Install the two left-hand opener mounts (4) under the toolbar frame (3). Install the eight 5/8 x 2-1/2 bolts (1), the eight 5/8 flat washers (2), and the eight 5/8 lock nuts (5). Tighten the bolts (1) and nuts (5) to 305 to 345 Nm (225 to 255 ibf-ft) .

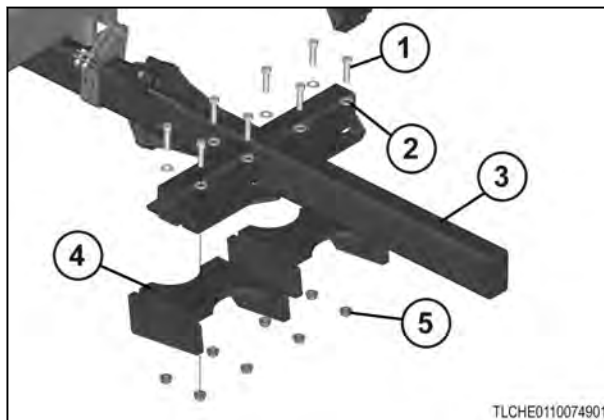

Fig. 71

4. Install a right-hand seed disc opener assembly (3) to the opener mount (4) with the rear column of holes (5) empty. Use the four 5/8 x 2-1/2 bolts (1), the four 5/8 flat washers (2), and the four 5/8 flanged lock nuts (6). Tighten the bolts (1) and nuts (6) to 187nm (138lb-ft).

**NOTE:** The seed scraper is always to the outside of the seed disc opener assembly (3). The front of the seed disc opener assembly will have a chamfer.

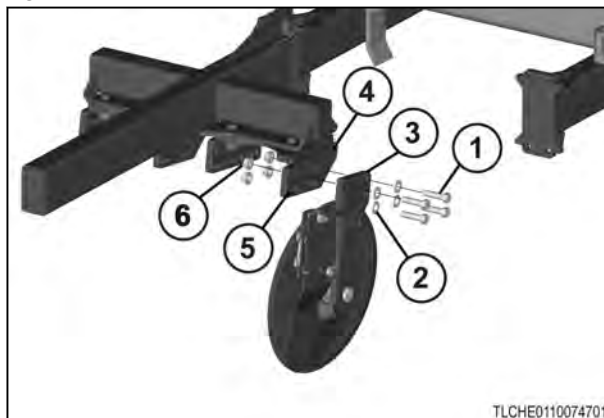

Fig. 72

5. Install a left-hand seed disc opener assembly (3) to the inside bracket of the opener mount (5) with the front column of holes (5) empty. Install the four 5/8 x 2-1/2 bolts (1), the four 5/8 flat washers (2), and the four 5/8 flanged lock nuts (6). Tighten the bolts (1) and nuts (6) to 187nm (138lb-ft).

**NOTE:** The seed scraper is always to the outside of the seed disc opener assembly (3). The front of the seed disc opener assembly will have a chamfer.

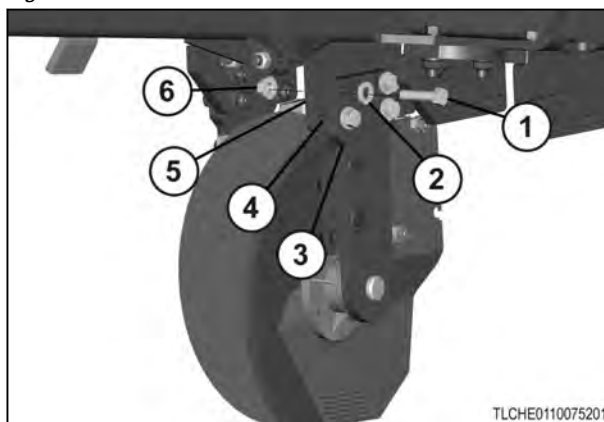

Fig. 73

6. Install the seed tube assemblies (1) on the mounting brackets (2), and secure the assemblies with the hair pins (3).

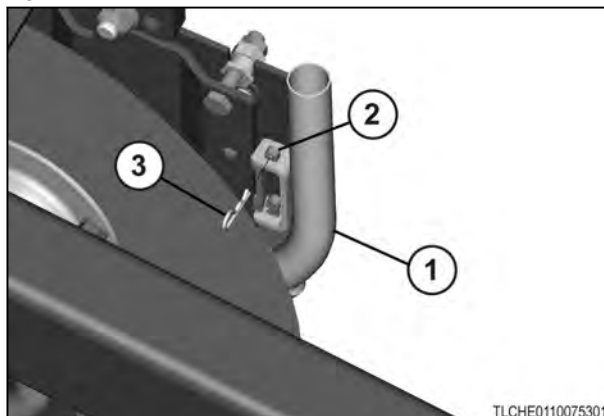

Fig. 74



7. Adjust all of the seed disc scraper nuts (1) to the same tension, and install the 1/2 jam nuts (1). See the information for adjusting the scrapers.

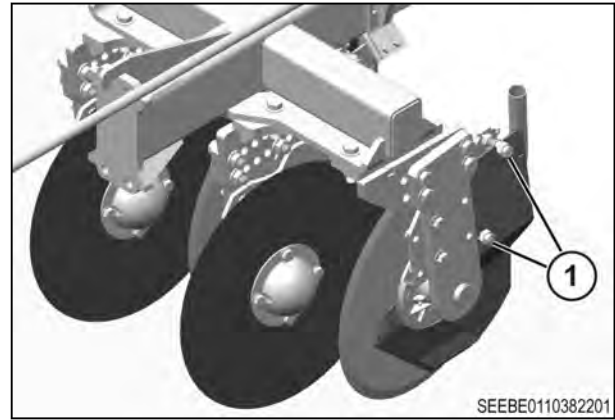

Fig. 75

8. Remove the packer wheel mounts and mark the left-hand mounts (1) with a "L", and mark the right hand mounts (2) with a "R". The left-hand and right-hand mounts are determined by the spindle tube orientation (3).

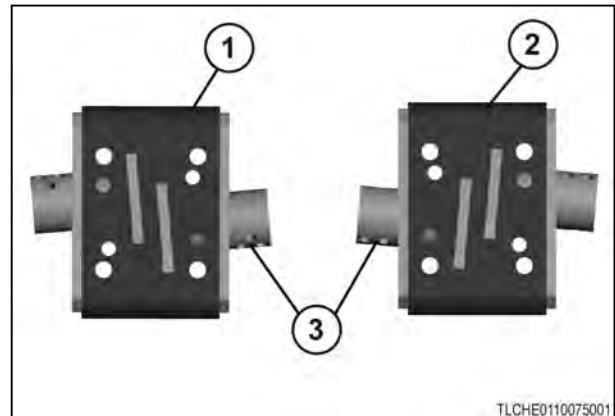

Fig. 76

9. Install the packer wheel mount (3) flush with the end of the toolbar frame (2). Install the two 5/8 x 6-1/2 x 3 x 6-1/2 U-bolts (1) over the toolbar frame (2), through the outer holes on the packer wheel mount (3). The rear U-bolt (1) should be 51 mm ( 2 inches ) from the toolbar end (2). Install the four 5/8 lock nuts (4).

**NOTE:** Use a left-hand packer wheel mount for left-hand toolbars and right-hand packer wheel mounts for the right-hand toolbars.

**NOTE:** Tighten the four 5/8 lock nuts (4) evenly, otherwise misalignment of the packer wheels may occur.

10. Install the 3/8 x 3 bolt (1) through the outer hole (4) on the outer packer wheel mount spindle tube, packer wheel hub (2). Install the 3/8 lock nut (3).

**NOTE:** All outer hubs (2) will use the outer most holes (4) on the packer wheel mount spindle tubes.

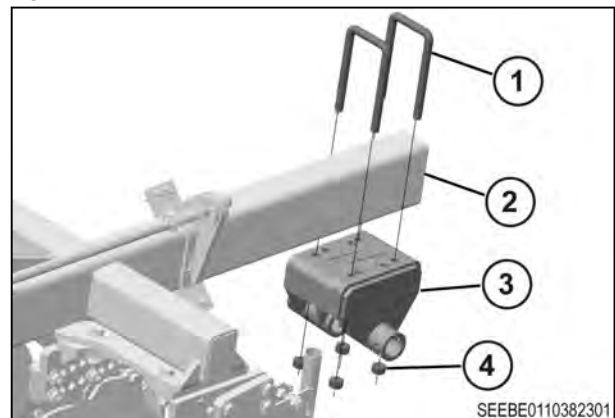

Fig. 77

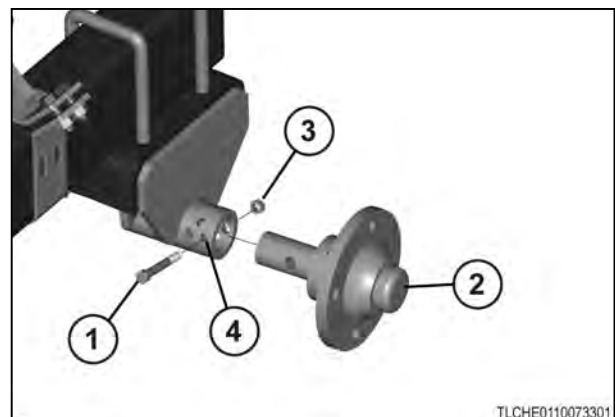

Fig. 78

11. Install the 3/8 x 3 bolt (1) through the inner most hole (4) on the inner packer wheel mount spindle tube, packer wheel hub (2). Install the 3/8 lock nut (3).

**NOTE:** All inner hubs (2) will use the inner most holes (4) on the packer wheel mount spindle tubes.

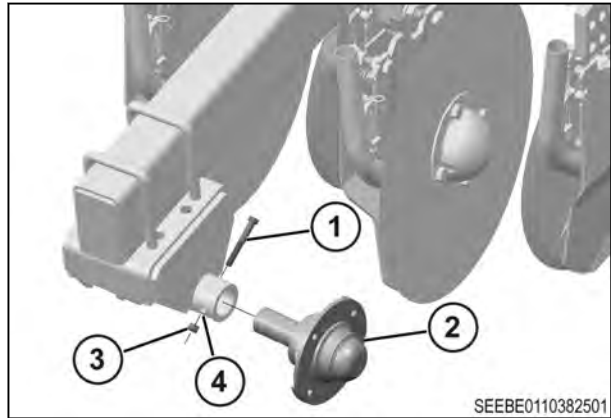

Fig. 79

12. Install the packer wheel (1) on the packer wheel hub (3), and install the wheel with the four wheel bolts (2). Tighten wheel bolts to 70-80Nm (52-60lb-ft).

**NOTE:** Install the packer wheels (1) with the valve stem to the outside.

13. Repeat step for the opposite packer wheel and hub.

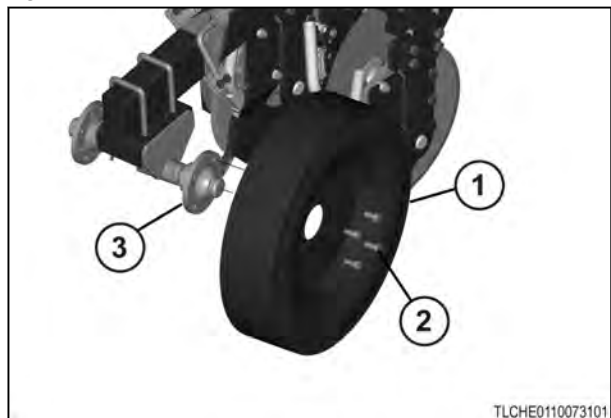

Fig. 80

14. Install the toolbar lock mount (2), the toolbar lock rod (3), and the toolbar lock bracket (6) on the toolbar frame (5). Install the four 1/2 x 1-1/2 bolts (1) and the 1/2 lock nuts (4).

**NOTE:** Do not tighten the nuts (4) completely.

**NOTE:** The toolbar lock assembly will be factory installed on the outer right-hand toolbar.

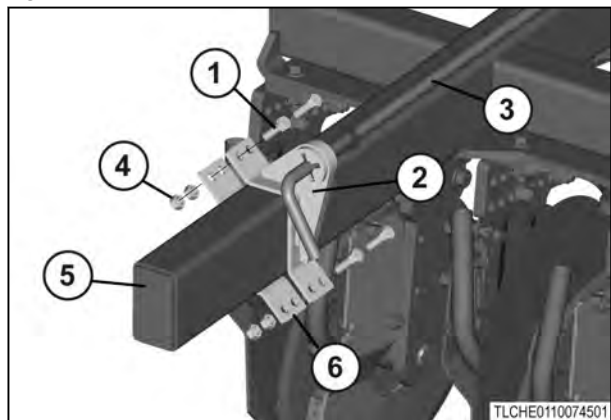

Fig. 81

15. Remove the shipping lock pin (1) from the toolbar lock mount and loosen the 1/2 x 1-1/2 bolts (2) and 1/2 nuts.

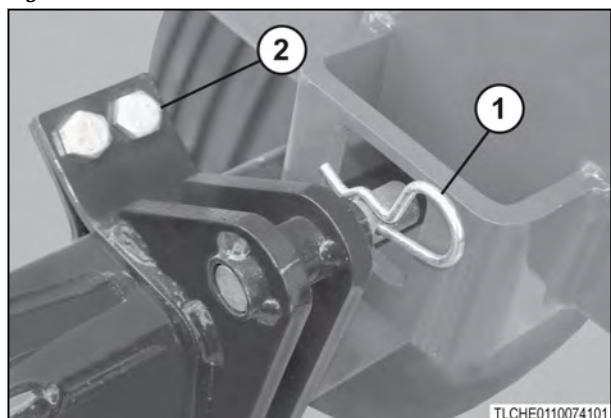

Fig. 82

16. Adjust the toolbar lock mount (1) from the frame lock (2) so that the clearance (3) is 9.5 mm (3/8 inches) wide.

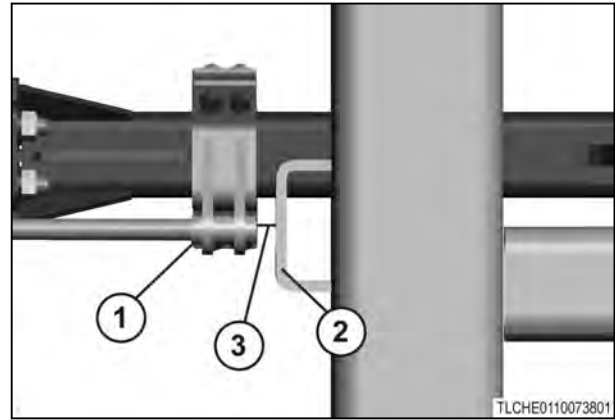

Fig. 83

17. Install the toolbar lock mount (2) in place with the four 1/2 x 1-1/2 bolts (1) and the 1/2 nuts.

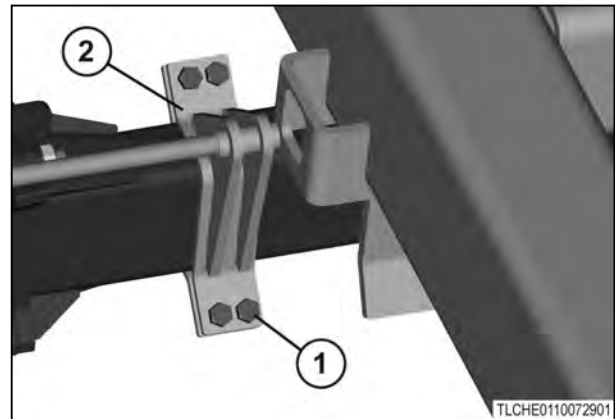

Fig. 84

18. Remove the locking rod shipping strap (1).

**NOTE:** The locking rod strap (1) is not installed on outer left-hand toolbar.

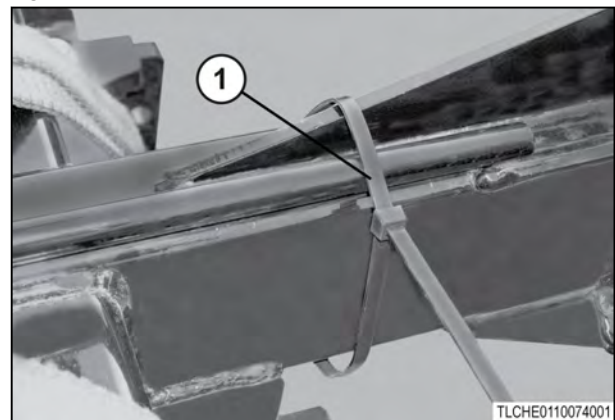

Fig. 85

19. Loosen the four 1/2 x 1-1/2 bolts (1) and 1/2 nuts, and disengage the toolbar lock rod (3) from the toolbar lock rod lock (2).

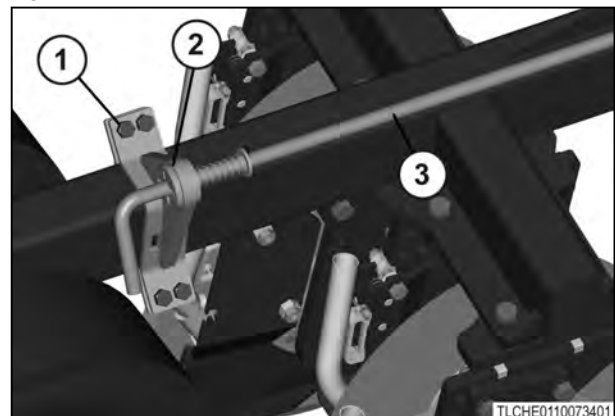

Fig. 86

20. Move the toolbar lock (1) and toolbar lock rod (2) into the toolbar lock rod mount (3).

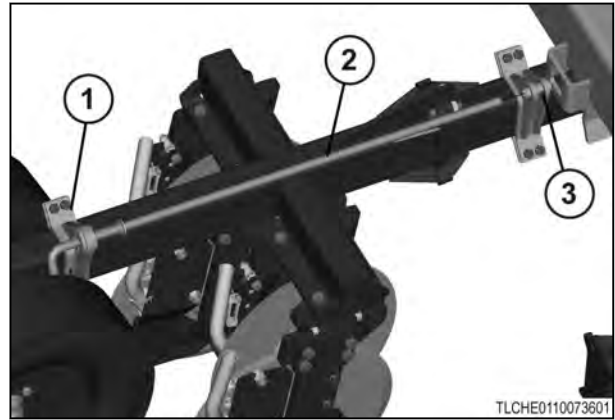

Fig. 87

21. Align the toolbar lock rod with the toolbar lock rod mount so that the ends are flush (1).

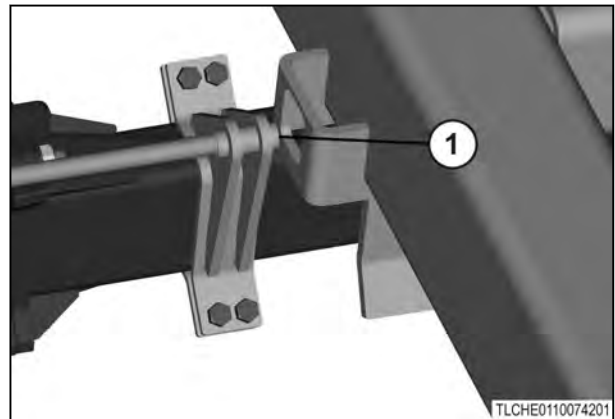

Fig. 88

22. Tighten the four 1/2 x 1-1/2 bolts (1) and 1/2 nuts on the toolbar lock rod lock, and engage the toolbar lock rod into the frame lock bracket.
23. Repeat all of the steps for the installation of the outer right-hand toolbar.

**NOTE:** The toolbar lock will factory installed on the right-hand toolbar frame.

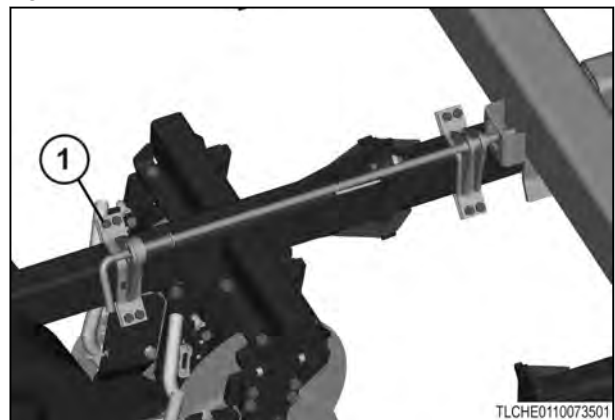

Fig. 89

### 7.3.3 Installing the assembled toolbars

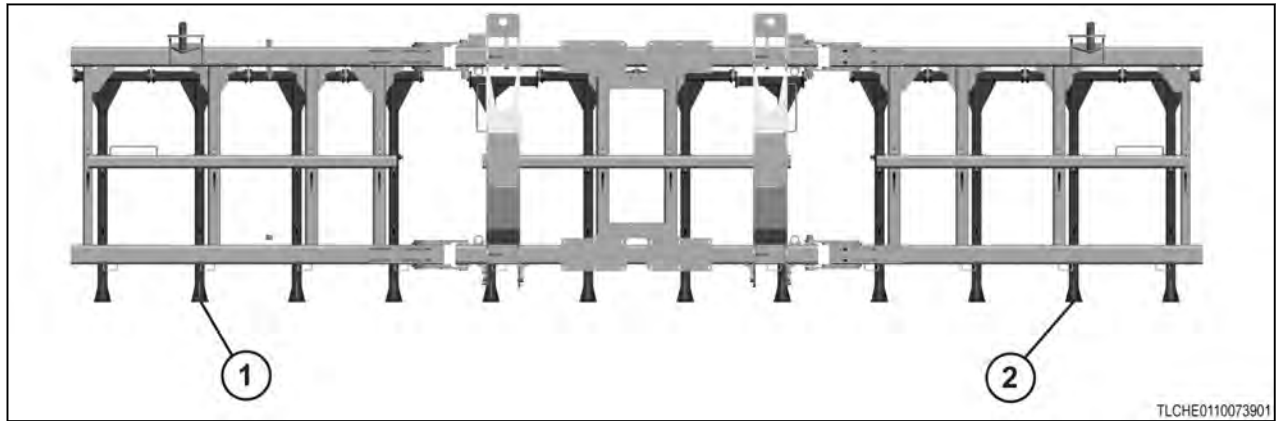

Fig. 90

1. Install the first factory assembled left-hand toolbar on the second outer left-hand frame (1). Install remaining left-hand toolbars while moving inwards. Install the first factory assembled right-hand toolbar on the second outer right-hand frame (2). Install remaining right-hand toolbars while moving inwards.

**NOTE:** 30ft frame shown, number of toolbars will be determined by frame size. Installation starting point will be the same for all of the frame sizes.

2. Install the toolbar (1) on the frame (2). Install the four  $5/8 \times 2-1/2$  fine thread bolts (3), the eight  $5/8$  flat washers (4) (5), and four the  $5/8$  nuts (6). Tighten the bolts (3) and nuts (6) to 170 Nm (125 lbf-ft).

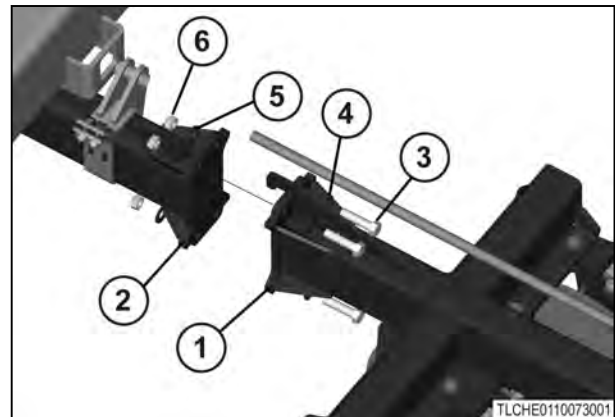

Fig. 91

3. Remove the packer wheel mounts and mark the left-hand mounts (1) with a "L", and mark the right-hand mounts (2) with a "R". The left-hand and right-hand mounts are determined by the spindle tube orientation (3).

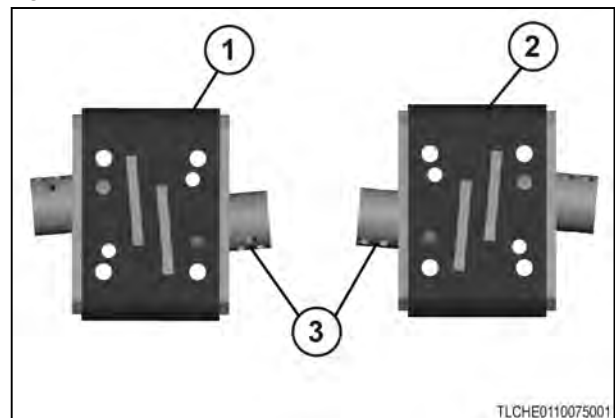

Fig. 92

4. Install the packer wheel mount (3) flush with the end of the toolbar frame (2). Install the two 5/8 x 6-1/2 x 3 x 6-1/2 U-bolts (1) over the toolbar frame (2), through the outer holes on the packer wheel mount (3). The rear U-bolt (1) is 51 mm (2 inches) from the toolbar end (2). Install the four 5/8 lock nuts (4).

**NOTE:** Use a left-hand packer wheel mount for left-hand toolbars and right-hand packer wheel mounts for right-hand toolbars.

**NOTE:** Tighten four the 5/8 lock nuts (4) evenly to make sure the packer wheels are aligned correctly.

5. Install the 3/8 x 3 bolt (1) through the outer hole (4) on the outer packer wheel mount spindle tube, through the packer wheel hub (2). Install the 3/8 lock nut (3).

**NOTE:** All outer hubs (2) will use the outer holes (4) on the packer wheel mount spindle tubes.

6. Install the 3/8 x 3 bolt (1) through the inner hole (4) on the inner packer wheel mount spindle tube, through the packer wheel hub (2). Install the 3/8 lock nut (3).

**NOTE:** All inner hubs (2) will use the inner holes (4) on the packer wheel mount spindle tubes.

7. Install the packer wheel (1) on the packer wheel hub (3), and install the wheel with the four wheel bolts (2). Tighten the wheel bolts to 70 to 80 Nm (52 to 60 lbf-ft) .

**NOTE:** Install the packer wheels (1) with the valve stem to the outside.

8. Repeat step for the opposite packer wheel and hub.

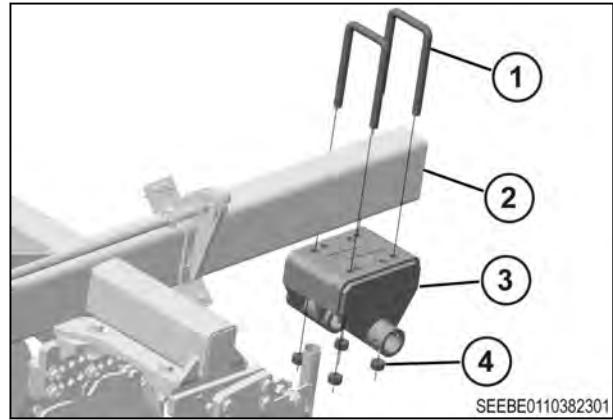

Fig. 93

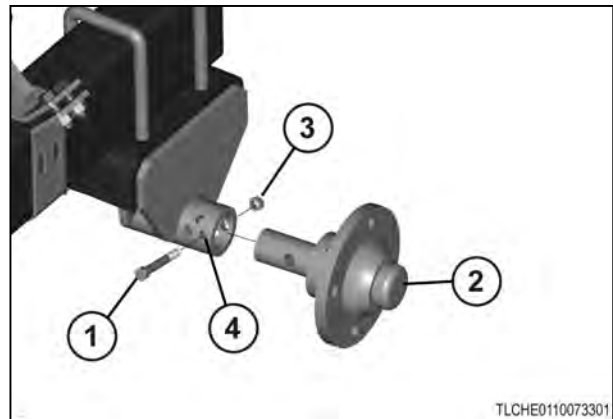

Fig. 94

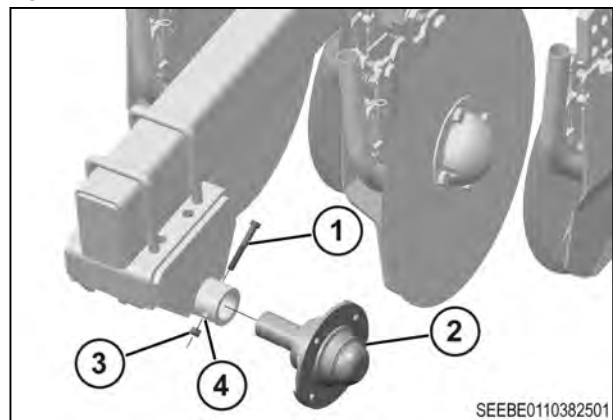

Fig. 95

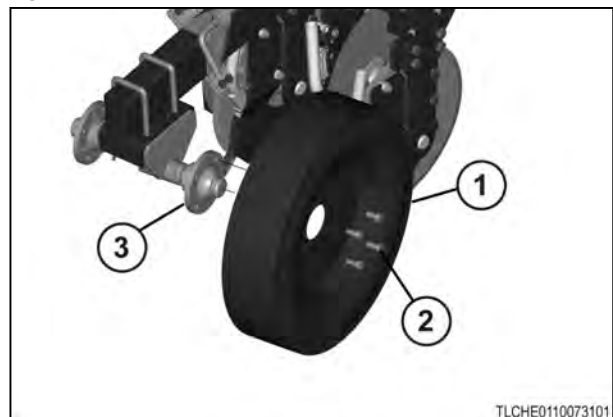

Fig. 96

9. Remove the shipping lock pin (1) from the toolbar lock mount and loosen the 1/2 x 1-1/2 bolts (2) and the 1/2 nuts.

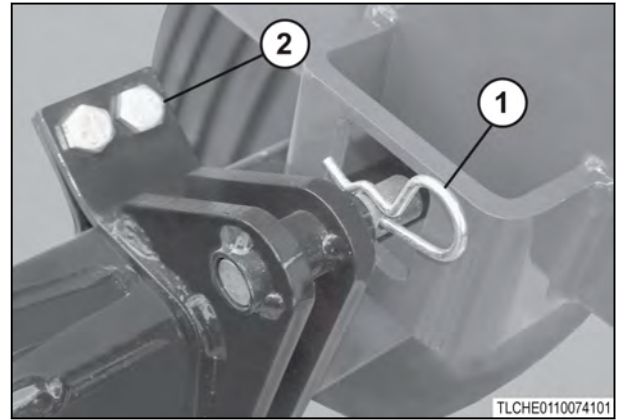

Fig. 97

10. Adjust the toolbar lock mount (1) from the frame lock (2) so that the clearance (3) is 9.5mm (3/8 inch) wide.

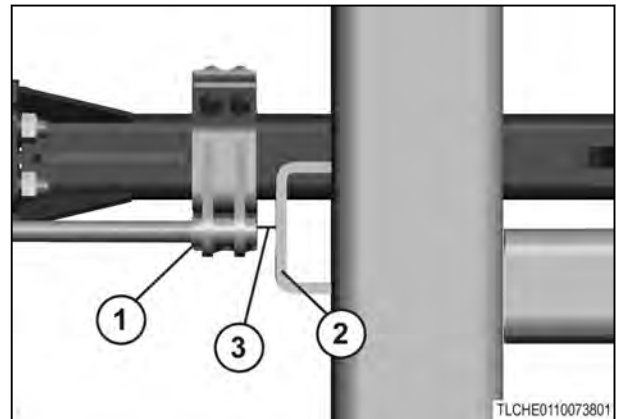

Fig. 98

11. Secure the toolbar lock mount (2) in place with the four 1/2 x 1-1/2 bolts (1) and the 1/2 nuts..

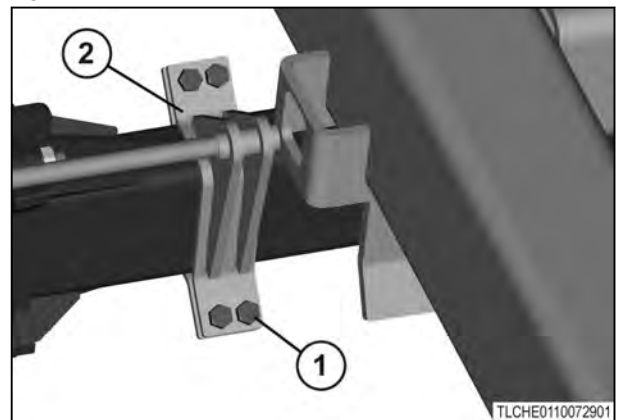

Fig. 99

12. Remove the locking rod shipping strap (1).

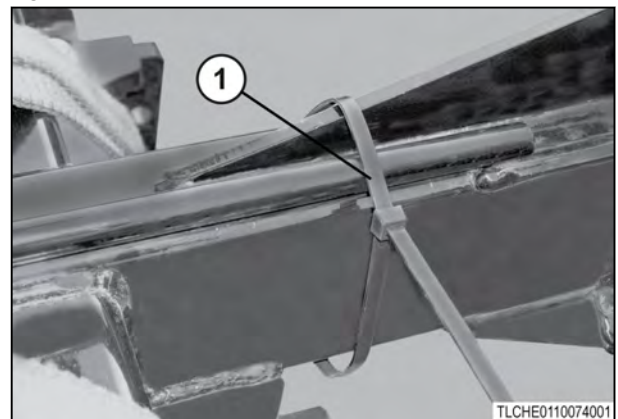

Fig. 100



13. Loosen the four 1/2 x 1-1/2 bolts (1) and the 1/2 nuts, and disengage the toolbar lock rod (3) from the toolbar lock rod lock (2).

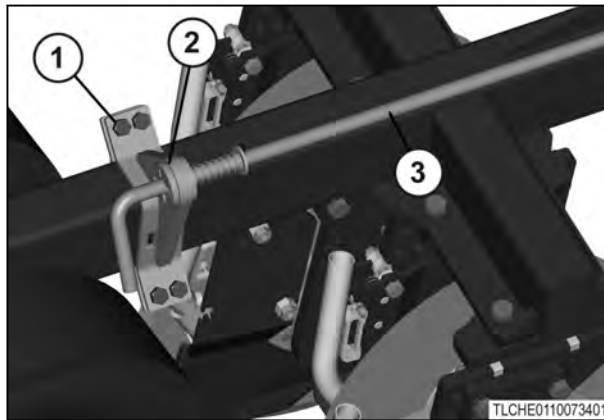

Fig. 101

14. Move the toolbar lock rod lock (1) and toolbar lock rod (2) into the toolbar lock rod mount (3).

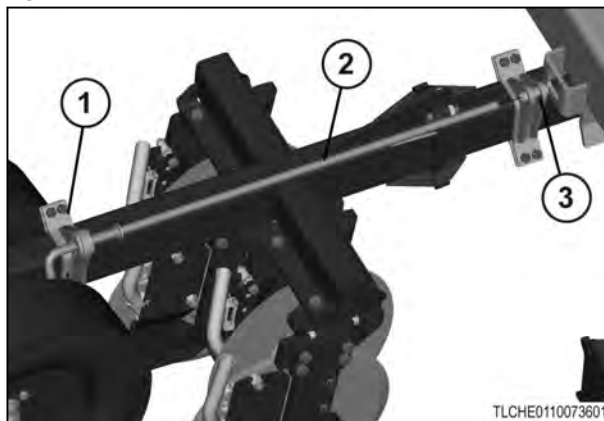

Fig. 102

15. Align the toolbar lock rod with the lock rod mount so the ends are flush (1).

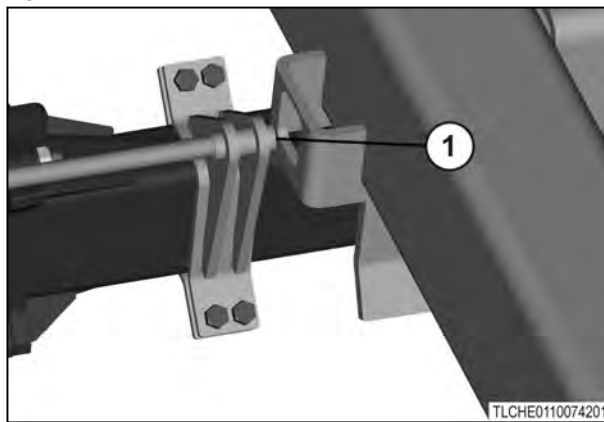

Fig. 103

16. Tighten the four 1/2 x 1-1/2 bolts (1) and the 1/2 nuts on the toolbar lock rod lock. Engage the toolbar lock rod into the frame lock bracket.

**NOTE:** *The outside toolbar installation process is different.*

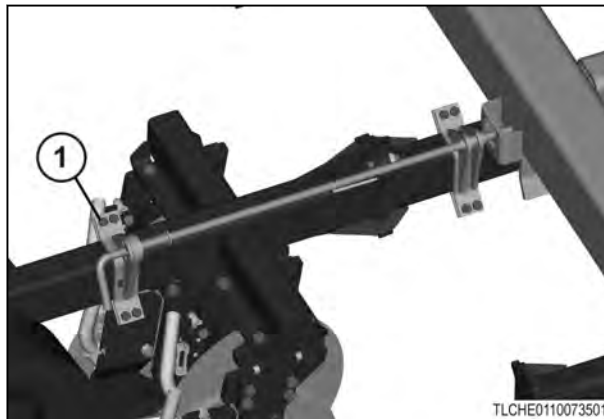

Fig. 104



## 7.4 Installing the front pull hitch

1. Find the right-hand mainframe hitch mount (1) and the draw pole pin (2).
2. Remove the 1/2 x 3 bolt (1) and the 1/2 lock nut (2) from the bottom of the draw pole pin (3).
3. Align the right-hand draw pole (3) with the mainframe hitch mount (3) and insert the draw pole pin (1) through both.

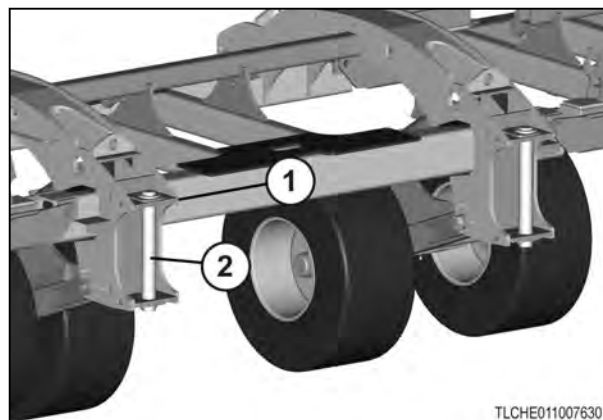

Fig. 105

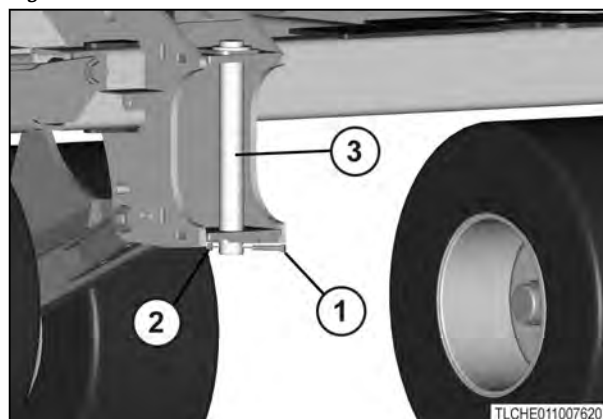

Fig. 106

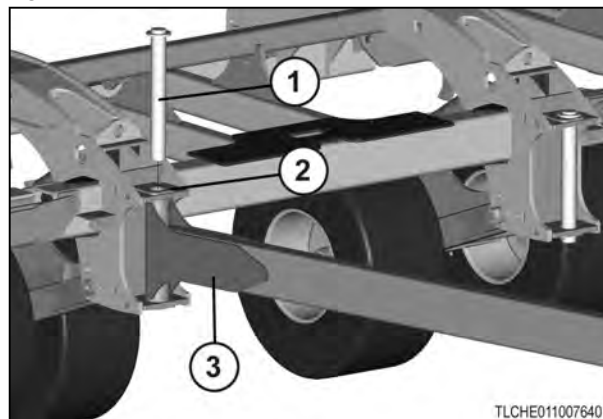

Fig. 107

4. Install the 1/2 x 3 bolt (1) and the 1/2 lock nut (3) to the draw pole pin (2).

**NOTE:** The left-hand draw pole must be installed before moving onto the next step. Repeat previous steps to install the left-hand draw pole.

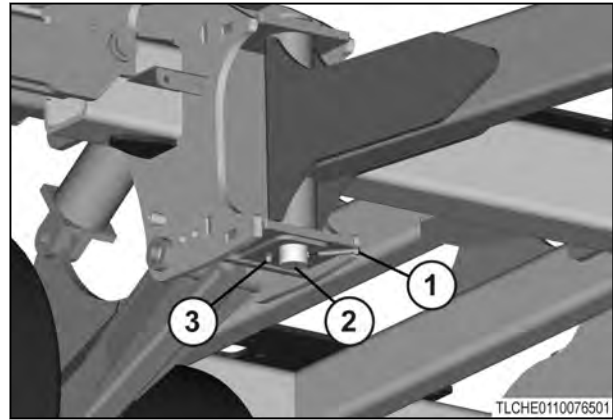

Fig. 108

5. Align the hitch mount assembly (4) to the right-hand draw pole (5). Install eight of the 3/4 x 2-1/2 bolts (1), sixteen of the 3/4 flat washers (2), and eight of the 3/4 nuts (3). Tighten the bolts and nuts to 540Nm (400lb-ft).

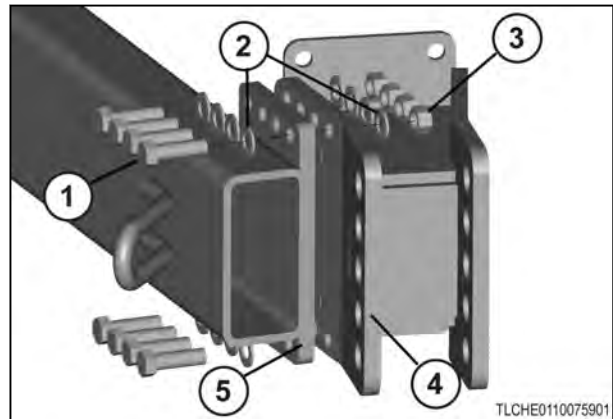

Fig. 109

6. Align the left-hand draw pole (4) with the hitch mount assembly (5). Install eight of the 3/4 x 2-1/2 bolts (1), sixteen of the 3/4 flat washers (2), and eight of the 3/4 nuts (3). Tighten the bolts and nuts to 540Nm (400lb-ft).

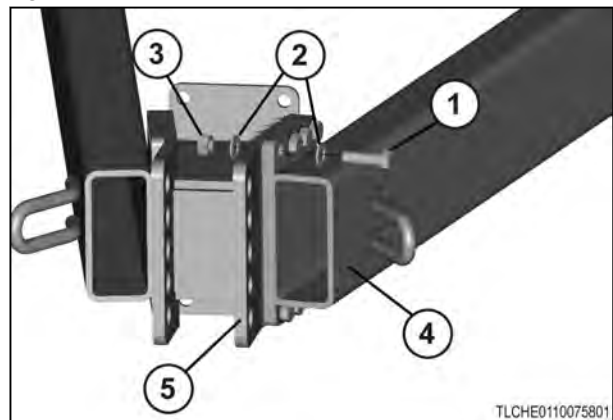

Fig. 110

7. Install the 3/8 x 3 stud (2) in the draw pole (1). Install the clamp (3) on the stud (2) with the 3/8 lock washer (4) and the 3/8 nut (5).

**NOTE:** There are six clamps on the inside of each draw pole.

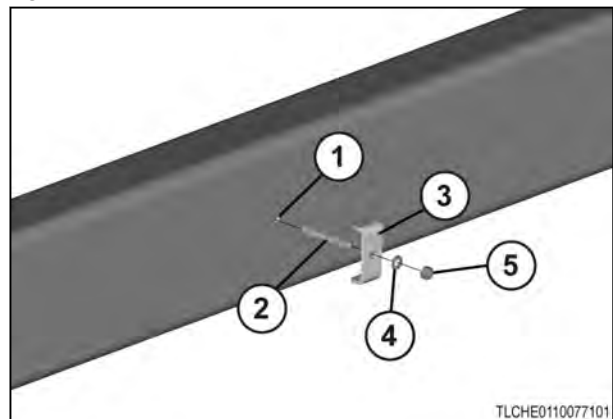

Fig. 111

8. Install the ring hitch (4) with two 1-1/4 x 9 bolts (1) 1-1/4 flat washers (2) and jam nuts (3).

**NOTE:**

The flange of the pivot ball must be installed down.

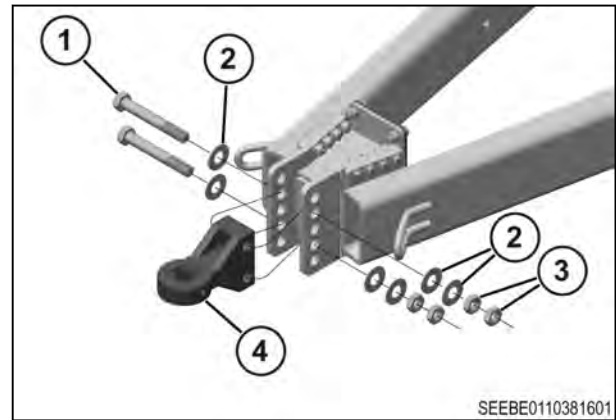

Fig. 112

9. Install the jack (1) with four 3/4 x 2 1/2 inch bolts (2), eight flat washers (3) and four 3/4 lock nuts (4).

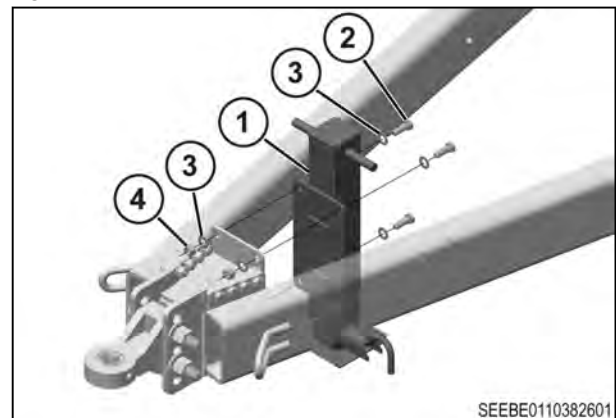

Fig. 113

10. Install the utility pole (3) with the 3/8 x 7 x 8 x 7 U-bolt (1), and the backing plate (2). Install the two 3/4 x 3/4 spacers (4) inside the utility pole frame. Install the two 3/8 washers (5), and the two 3/8 lock nuts (6).

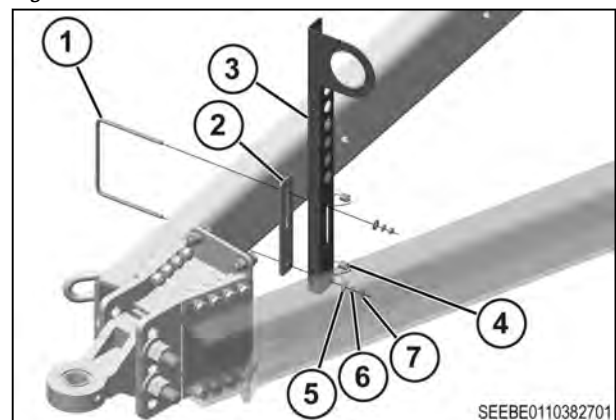

Fig. 114

11. Install the light plug holder (2) to the utility pole (4) with the two 1/4 x 1 bolts (3) and the two 1/4 lock nuts (1).

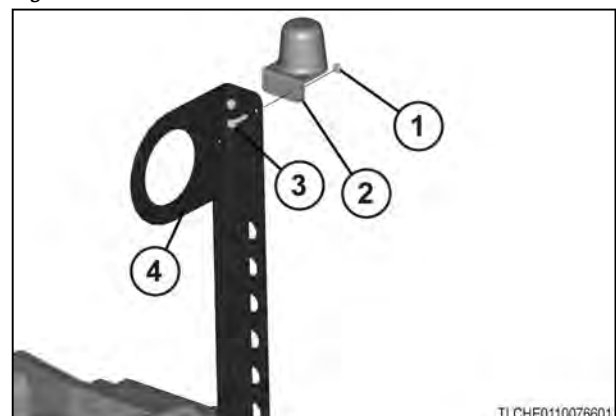

Fig. 115

- 12.** Install the storage tube (1) to the utility pole (5) with the 1/4 x 3/4 bolt (2), the 1/4 washer (3), and the 1/4 nut (4).

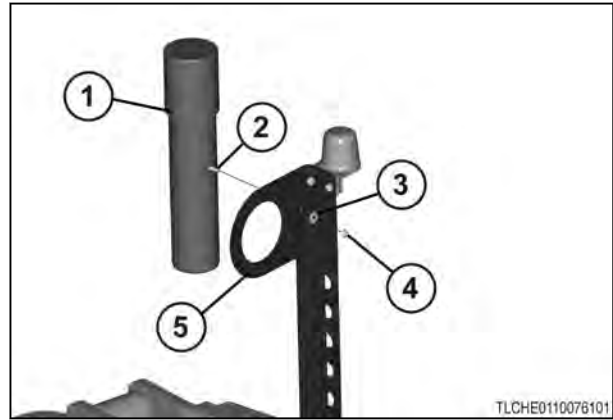

Fig. 116

- 13.** Install the weather stripping (1) to the utility pole bracket.

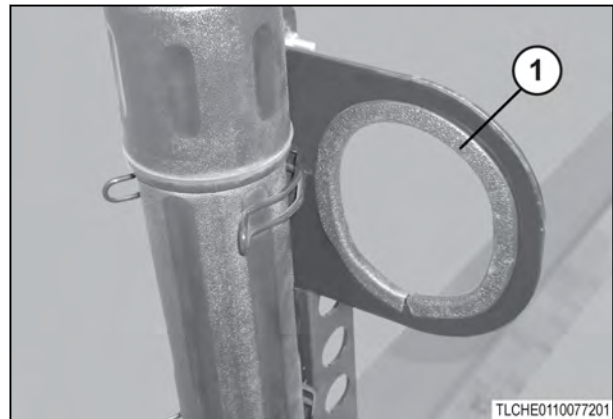

Fig. 117

## 7.5 Installing the frame height control hydraulics

1. Align the hydraulic cylinder base (2) with lift wheel strut (3) and insert the 1 x 3-3/8 pin (1).  
Install all of the hydraulic cylinders with ports facing an upward direction.

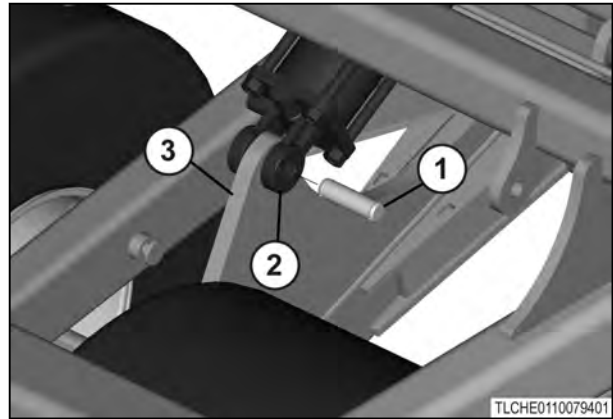

Fig. 118

2. Install the two 1 inch retainer rings (1) on the 1 x 3-3/8 pin (2).  
Repeat previous steps on all of the frame height cylinders before completing the next step.

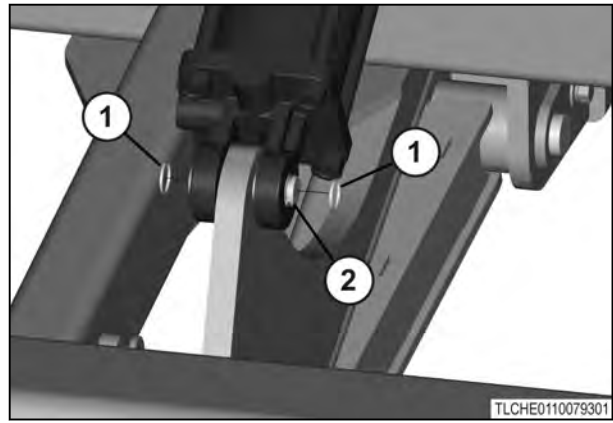

Fig. 119

3. Align the height hydraulic cylinder (3) with the main frame bracket (1) and insert the 1 x 3-3/8 pin (2).

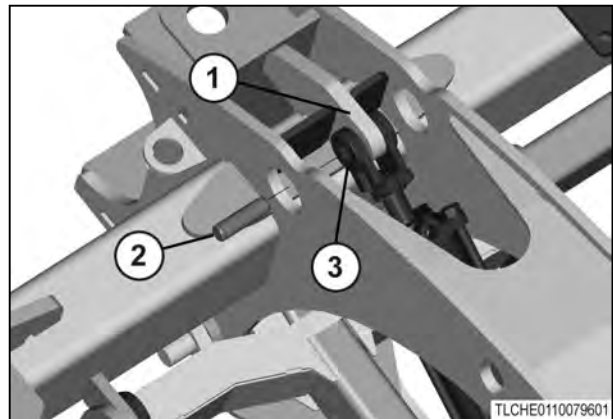

Fig. 120

4. Install the two 1 inch retainer rings (1) on the 1 x 3-3/8 pin (2).

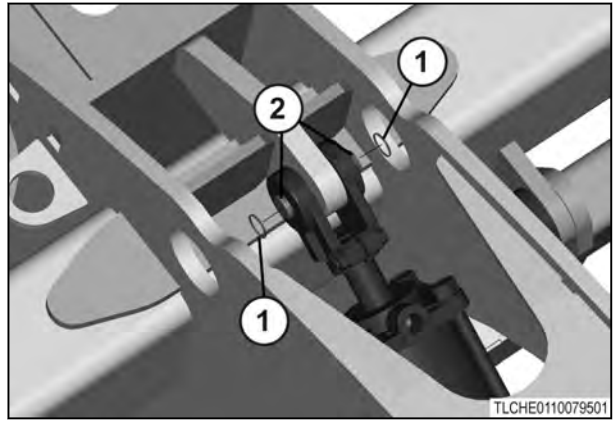

Fig. 121

5. Install the leveler screw (1) through the wing level mount tube (2) and install the lower 2 inch jam nut (3).

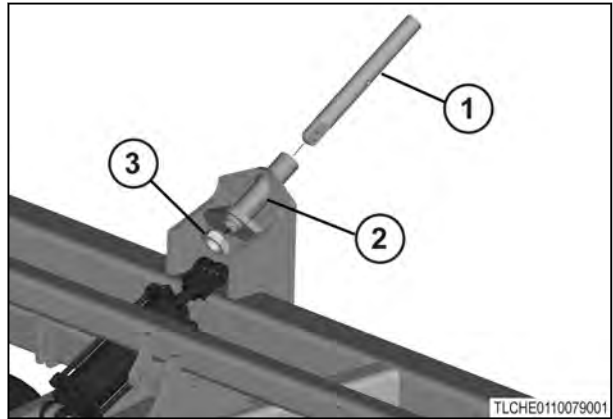

Fig. 122

6. Install the upper 2 inch jam nut (2) on the leveler screw (1) until there is 7 cm (2-3/4) from the base of the jam nut (2) to the end of the leveler screw (1)

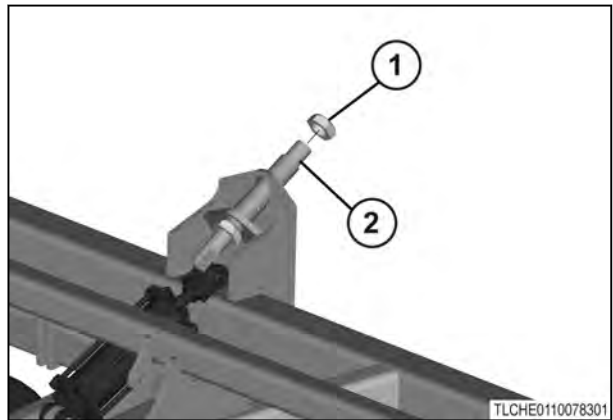

Fig. 123

7. Install the 1/2 x 3 roll pin (1) through the lever screw (2).

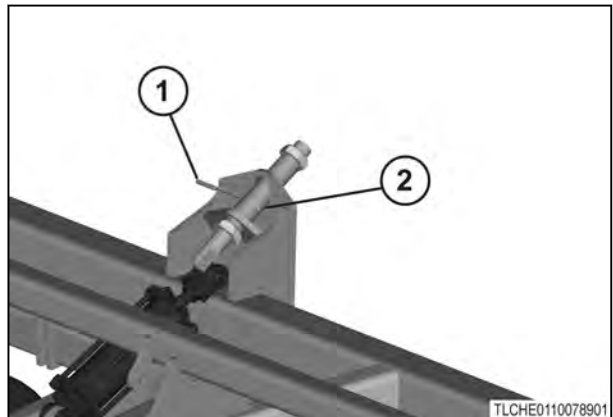

Fig. 124

8. Align the height cylinder (2) with the leveler screw and insert the 1 x 3-3/8 pin (1).

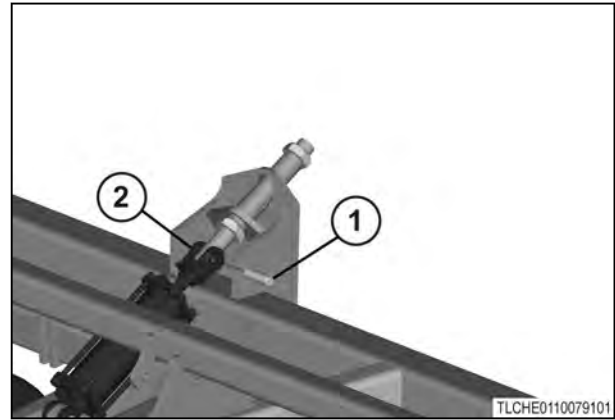

Fig. 125

9. Install the two 1 inch retainer rings (1) on the 1 x 3-3/8 pin (2).

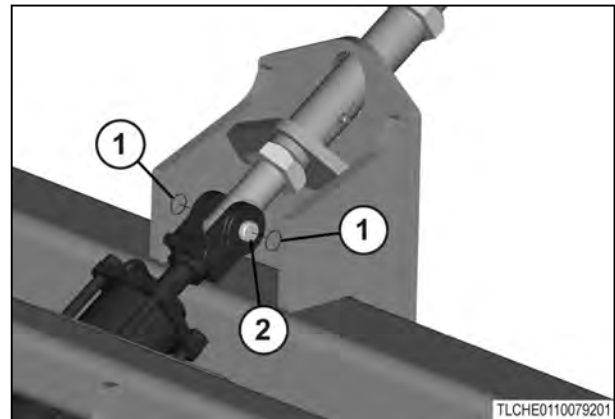

Fig. 126

10. Install two of the 8MB-8MJ-90 adapters (1) in the ports (2) on each of the frame height hydraulic cylinders.

**NOTE:** Do not tighten the jam nuts on the hydraulic adapters (1).

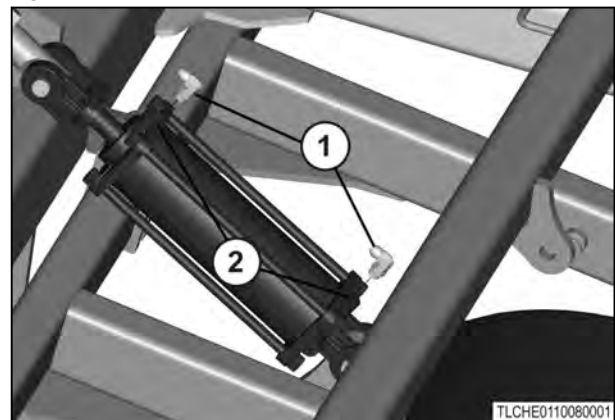

Fig. 127

11. Install two of the 8MB-8MJ adapters (4) (5) and two of the O-rings (3) (2) in ports RCE and RCR on the height control flow divider (1).

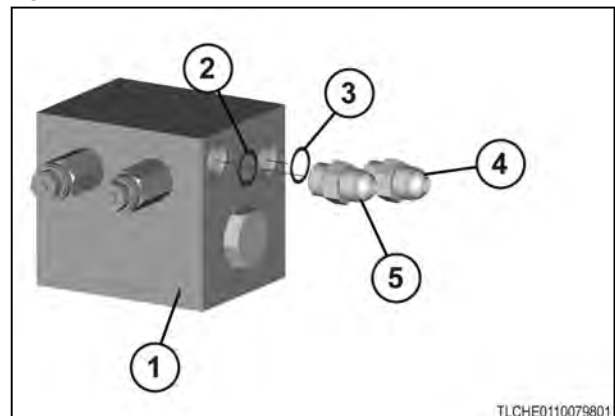

Fig. 128

12. Install two of the 8MB-8MJ adapters (4) (6) and two of the O-rings (3) (5) in the ports LCE and LCR.
13. Install two of the 8MB-8MJ-90 adapters (1) (2) in the ports TE and TR.

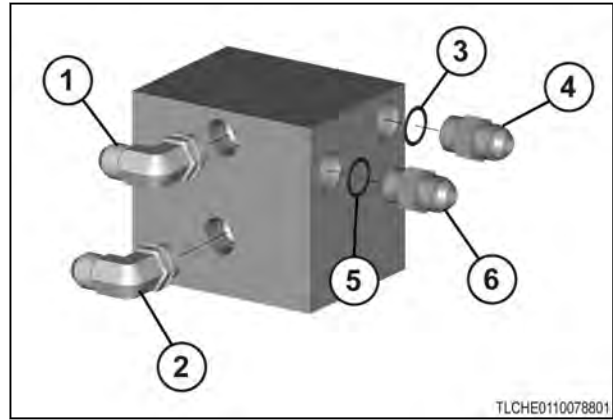

Fig. 129

14. Install the assembled depth control flow divider (1) to the main frame (2). Install the four 3/8 lock washers (3) and the four 3/8 x 1-1/4 bolts (4).

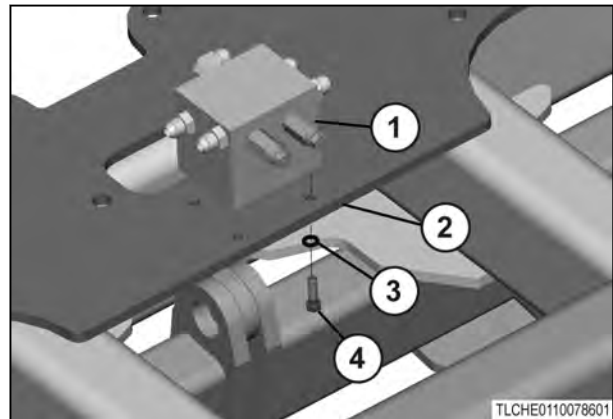

Fig. 130

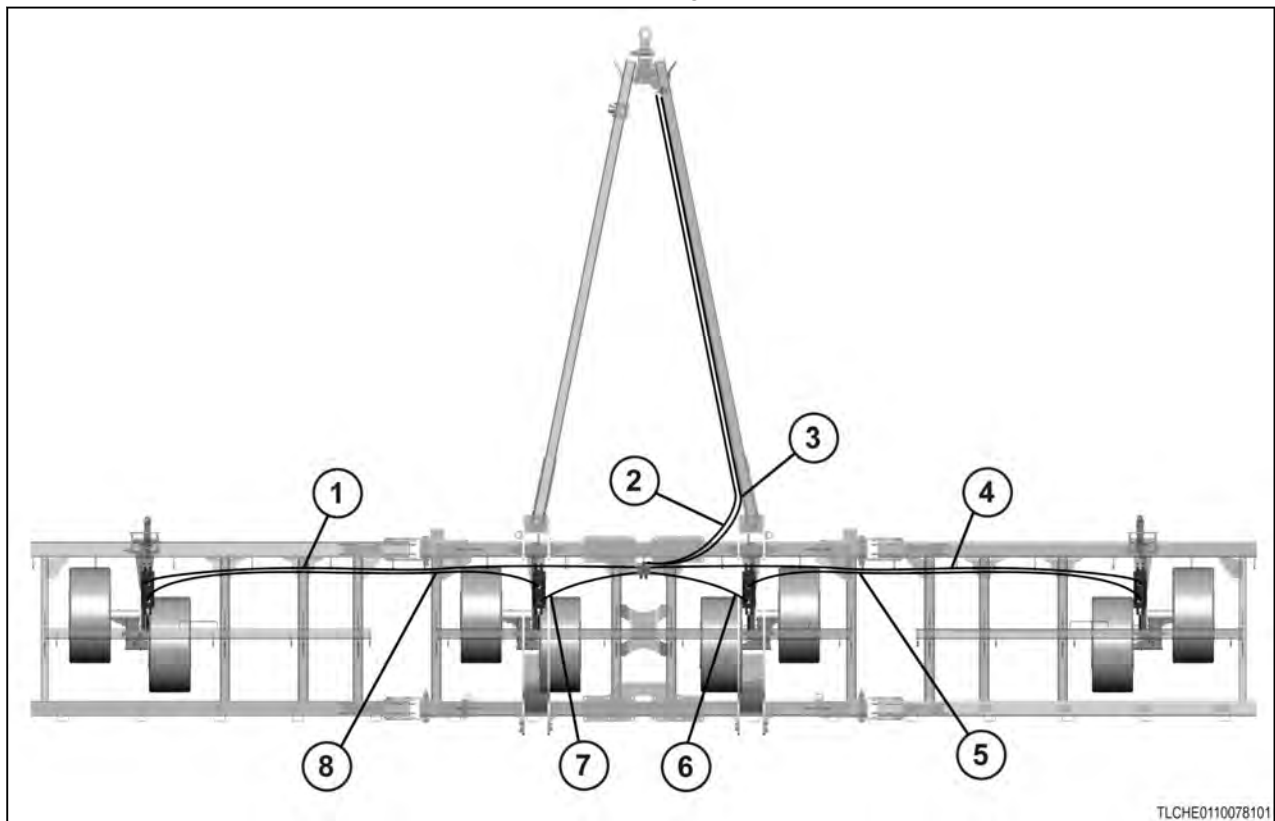

Fig. 131

15. Install the left-hand 1/2 x 207 8FJX-FJX hose (1) to the LCE port adapter on the height control flow divider. Route the hose to the outer right-hand frame height control hydraulic cylinder. Install the hose to the upper port adapter.



16. Install the right-hand 1/2 x 207 8FJX-FJX hose (4) to the RCE port adapter on the height control flow divider. Route the hose to the outer left-hand frame height control hydraulic cylinder. Install the hose to the lower port adapter.
17. Install the left-hand 1/2 x 48 8FJX-8FJX hose (7) to the RCR port adapter on the height control flow divider. Route the hose to the left-hand main frame height control cylinder. Install the hose to the lower port adapter.
18. Install the right-hand 1/2 x 48 8FJX-8FJX hose (6) to the LCR port adapter on the height control flow divider. Route the hose to the right-hand main frame height control cylinder. Install the hose to the lower port adapter.
19. Install the 1/2 x 306 8FJX-8FJX hose (2) to the TR port adapter on the front of the height control flow divider. Route the hose through frame, along the inside of the right-hand side of the front hitch to the utility pole.
20. Install the 1/2 x 306 8FJX-8FJX hose (3) to the TE port adapter on the front of the height control flow divider. Route the hose through frame, along the inside of the right-hand side of the front hitch to the utility pole.
21. Install the left-hand 1/2 x 172 8FJX-8FJX hose (8) to the upper port adapter on the left-hand main frame height control cylinder. Route the hose to the outer left-hand frame height control cylinder, and install the hose to the lower port adapter.
22. Install the right-hand 1/2 x 172 8FJX-8FJX hose (5) to the upper port adapter on the right-hand main frame height control cylinder. Route the hose to the outer left-hand frame height control cylinder, and install the hose to the lower port adapter.

**NOTE:** The 40ft frame is shown. For the 30ft frame use the 1/2 x 172 8FJX-8FJX hoses (8) (5) instead of the 1/2 x 120 8FJX-8FJX hoses. Use the 1/2 x 207 8FJX-FJX hoses (4) (1) instead of the 1/2 x 152 8FJX-8FJX hoses.

23. Tighten the upper and lower jam nuts on all of the cylinder port adapters.

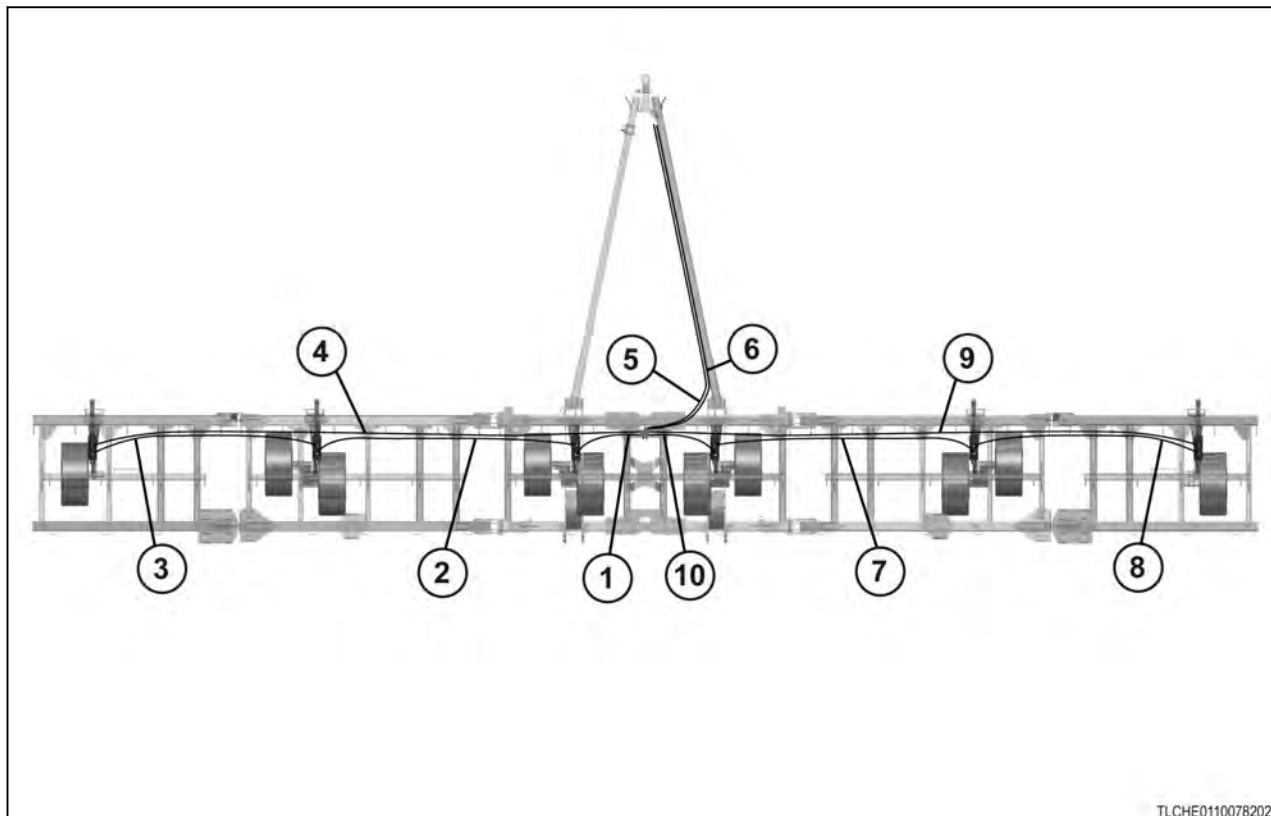

Fig. 132

24. Install the left-hand 1/2 x 342 8FJX-FJX hose (4) to the LCE port adapter on the height control flow divider. Route the hose to the outer right-hand frame height control hydraulic cylinder. Install the hose to the upper port adapter.

25. Install the right-hand 1/2 x 342 8FJX-FJX hose (9) to the RCE port adapter on the height control flow divider. Route the hose to the outer left-hand frame height control hydraulic cylinder. Install the hose to the lower port adapter.
  26. Install the left-hand 1/2 x 48 8FJX-8FJX hose (1) to the RCR port adapter on the height control flow divider. Route the hose to the on the left-hand main frame height control cylinder. Install the hose to the lower port adapter.
  27. Install the right-hand 1/2 x 48 8FJX-8FJX hose (10) to the LCR port adapter on the height control flow divider. Route the hose to the right-hand main frame height control cylinder. Install the hose to the lower port adapter.
  28. Install the 1/2 x 306 8FJX-8FJX hose (5) to the TR port adapter on the front of the height control flow divider. Route the hose through frame, along the inside of the right-hand side of the front hitch to the utility pole.
  29. Install the 1/2 x 306 8FJX-8FJX hose (6) to the TE port adapter on the front of the height control flow divider. Route the hose through frame, along the inside of the right-hand side of the front hitch to the utility pole.
  30. Install the left-hand 1/2 x 172 8FJX-8FJX hose (2) to the upper port adapter on the left-hand main frame height control cylinder. Route the hose to the left-hand wing frame height control cylinder, and install the hose to the lower port adapter.
  31. Install the right-hand 1/2 x 172 8FJX-8FJX hose (7) to the upper port adapter on the right-hand main frame height control cylinder. Route the hose to the right-hand wing frame height control cylinder, and install the hose to the lower port adapter.
  32. Install the left-hand 1/2 x 152 8FJX-8FJX hose (3) to the upper port adapter on the left-hand wing frame height control cylinder. Route the hose to the left-hand wing extension frame height control cylinder, and install the hose to the lower port adapter.
  33. Install the right-hand 1/2 x 152 8FJX-8FJX hose (8) to the upper port adapter on the right-hand wing frame height control cylinder. Route the hose to the right-hand wing extension frame height control cylinder, and install the hose to the lower port adapter.
- NOTE:** *The 60ft frame is shown. For the 50ft frame use the 1/2 x 342 8FJX-8FJX hoses (4) (9) instead of the 1/2 x 282 8FJX-8FJX hoses. Use the 1/2 x 172 8FJX-FJX hoses (2) (7) instead of the 1/2 x 152 8FJX-8FJX hoses. Use the 1/2 x 152 8FJX-8FJX hoses (3) (8) instead of the 1/2 x 114 8FJX-8FJX hoses.*
34. Tighten the upper and lower jam nuts on all of the cylinder port adapters.
  35. Install the two #8 ORB male couplings (1) on the front of the 1/2 x 306 8FJX-8FJX hoses.
  36. Install the two DEPTH decals (2) on the front of the hoses.

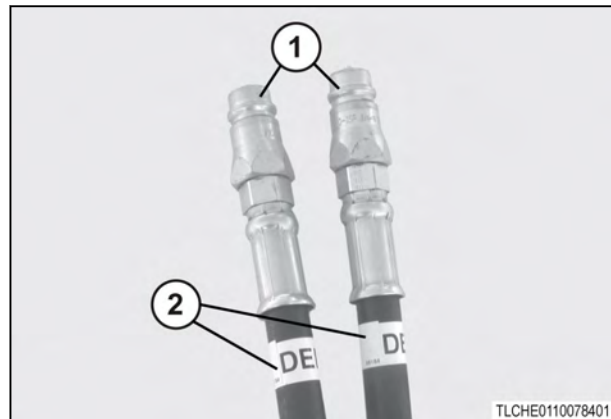

Fig. 133

- 37.** Install the 1/2 clamps (3) in the 3/8 holes (4).  
Install the 3/8 x 1 bolts (1) and the 3/8 lock washers (2).

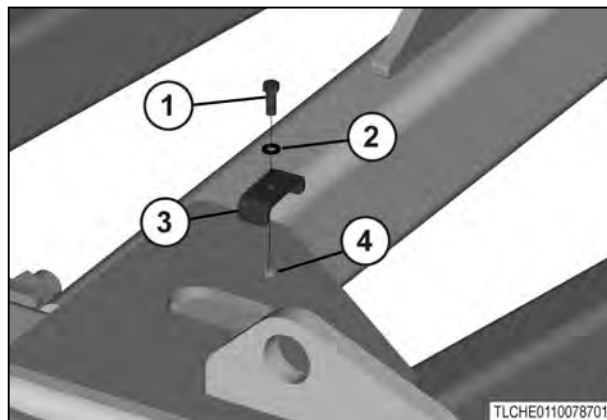

Fig. 134

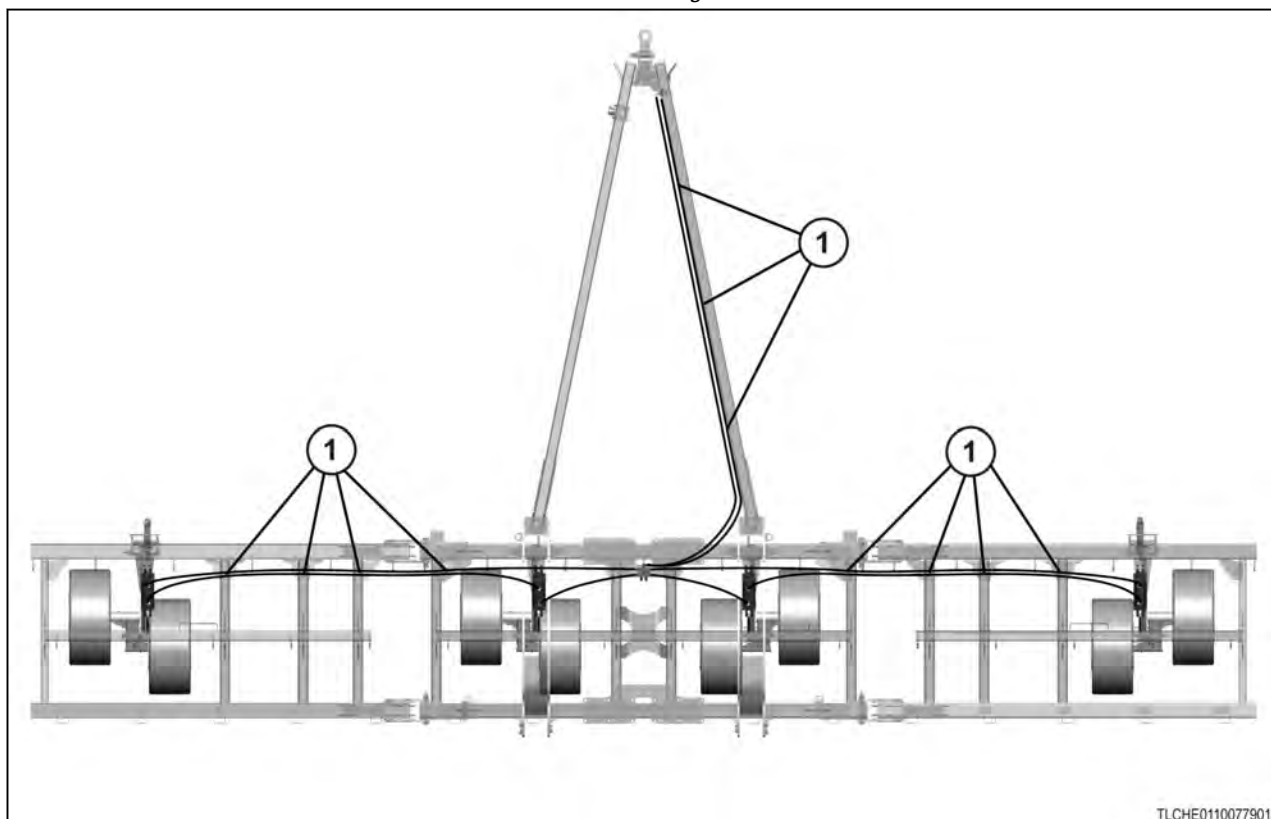
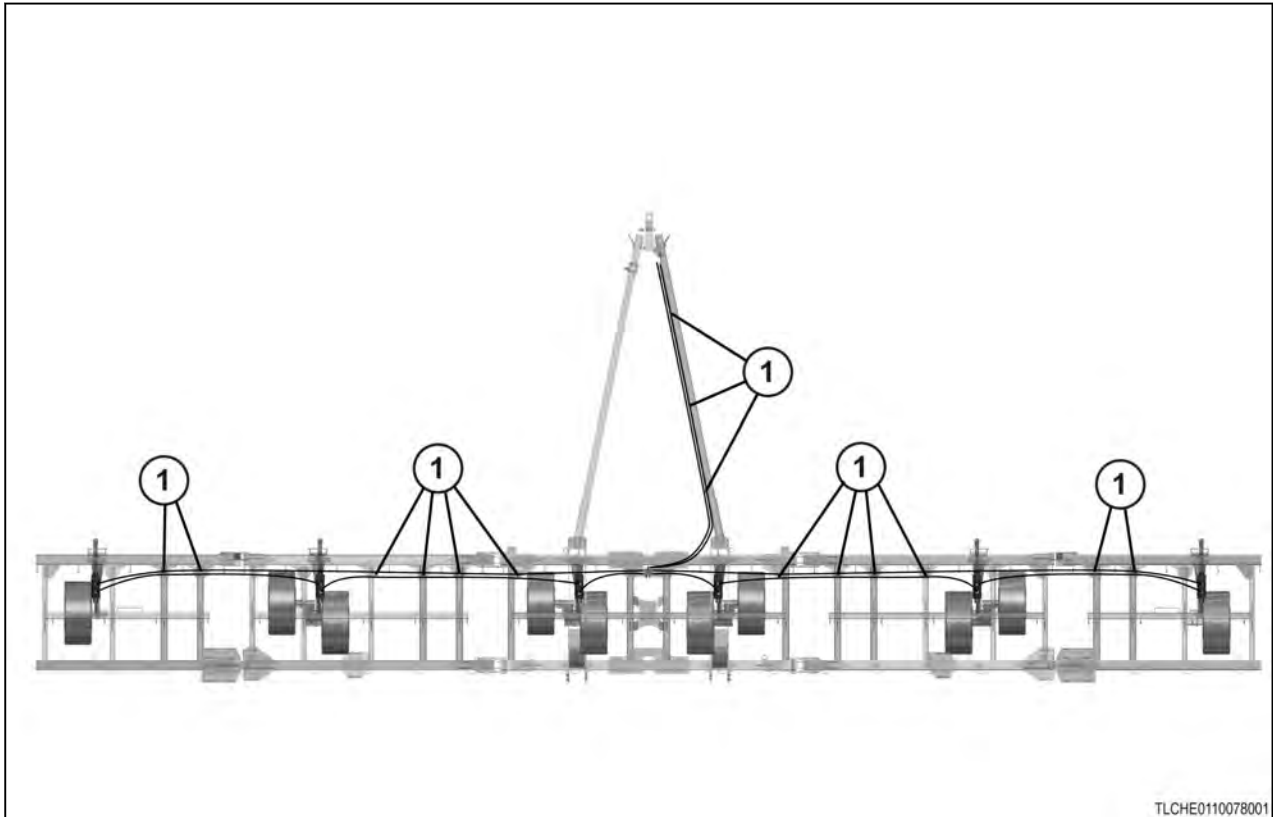

Fig. 135

- 38.** Install the clamps over the hoses on the 30ft and 40ft frames at marked locations (1).



TLCHE0110078001

Fig. 136

- 39. Install the clamps over the hoses on the 50ft and 60ft frames at the marked locations (1).
- 40. Install the cylinder stops (1) on the frame brackets (2).

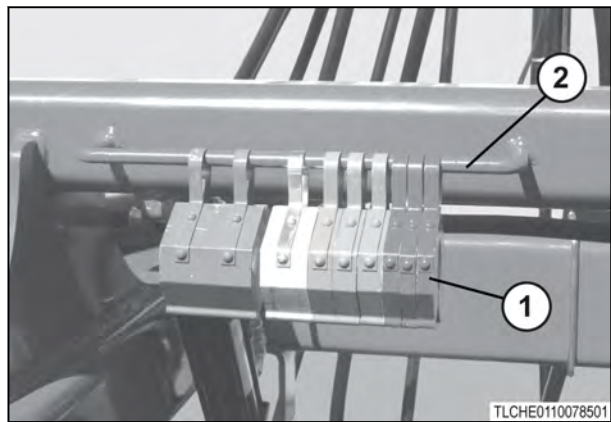

TLCHE0110078501

Fig. 137

## 7.6 Installing the work switch sensor

1. Remove the C-clips (1) from the 1 x 3/8 pin (2) on the left-hand main frame height cylinder (3).

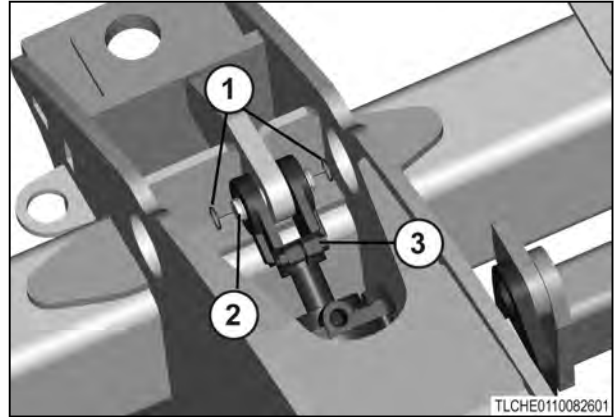

Fig. 138

2. Install the two work switch cylinder brackets (2) and replace the two C-clips (1) on the pin.

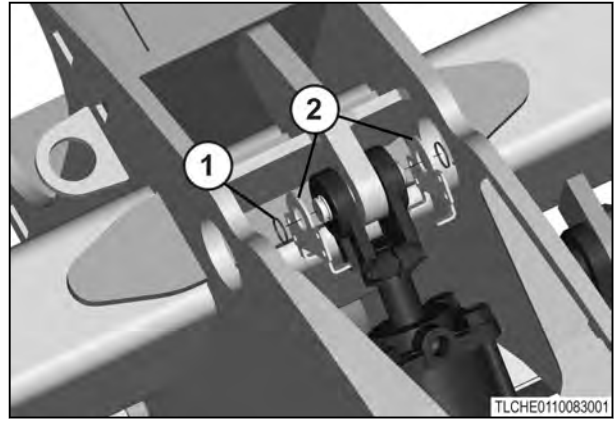

Fig. 139

3. Install the work switch top mount (2) and the work switch arm (1) with the four 1/4 x 3/4 carriage bolts (4) and the four 1/4 lock nuts (3).

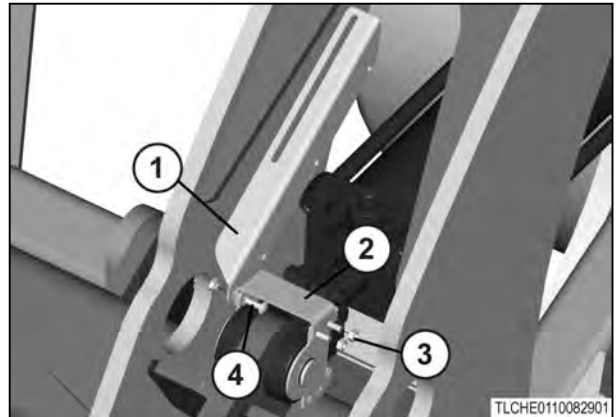

Fig. 140

4. Install the work switch sensor (1) at the end of the slot in work switch arm.
5. Install the 1/2 clamp with the 1/4 x 3/4 carriage bolt (5) and the 1/4 lock nut (4).
6. Raise the main frame to the maximum height. Remove the adhesive backing from the magnet (3) and install it in line with the work switch sensor (1).

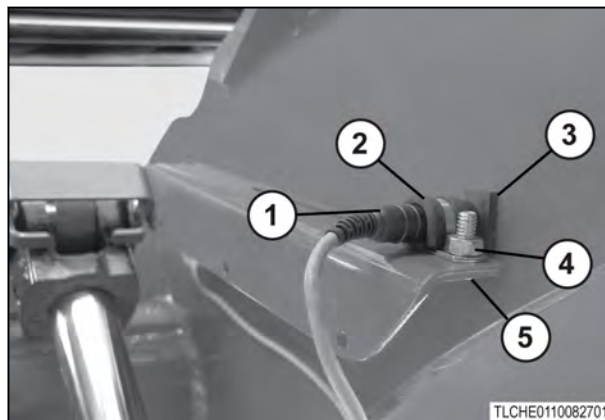

Fig. 141

7. Install the harness to the work switch arm (1).
8. Route harness through the main frame (2) to the ISO harness connection.

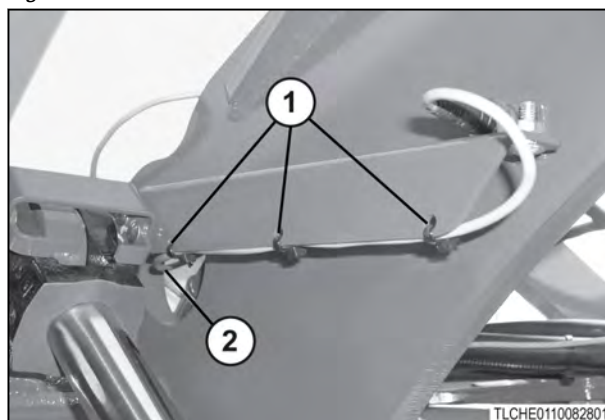

Fig. 142

## 7.7 Installing the floating rear hitch

### 7.7.1 Installing the down pressure hydraulics on the floating rear hitch

1. Align the down pressure cylinder base (3) with the frame toolbar mounting bracket (2). Install the 1 x 3-3/8 pin (1).

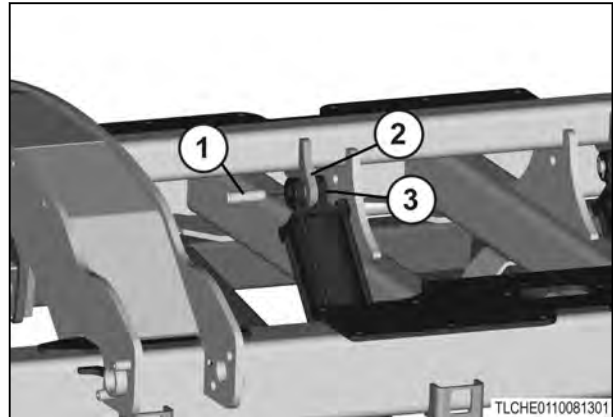

Fig. 143

2. Install the two clevis pins (1) through the 1 x 3-3/8 pin (2).

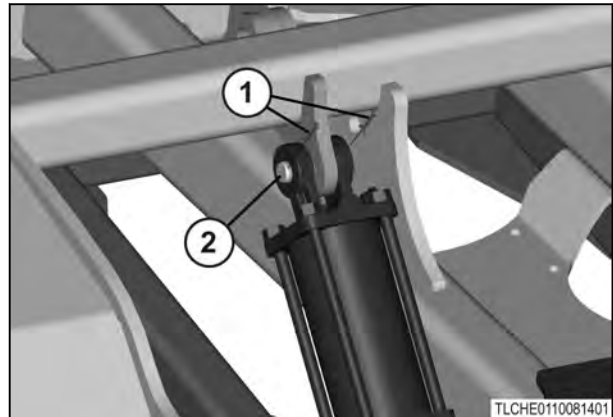

Fig. 144

3. Align the down pressure cylinder piston rod (2) with the toolbar mounting bracket (3). Install the 1 x 3-3/8 pin (1).

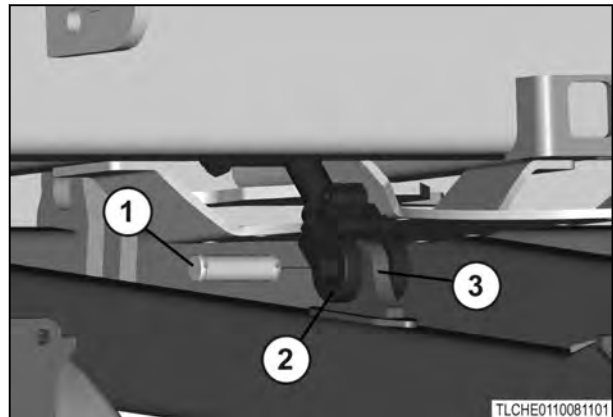

Fig. 145

4. Install the two clevis pins (1) through the 1 x 3-3/8 pin (2).  
Install all of the remaining down pressure cylinders before beginning the next step.

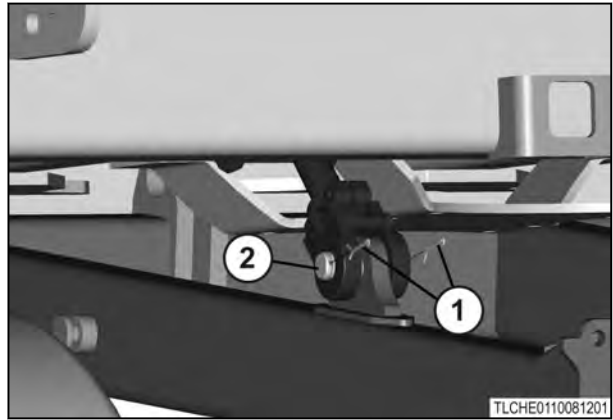

Fig. 146

5. Install the 8MJ-8MJ-8MB adapter (2) and the 8MB-8MJ-8MJ adapter (3) in the middle cylinders (1).

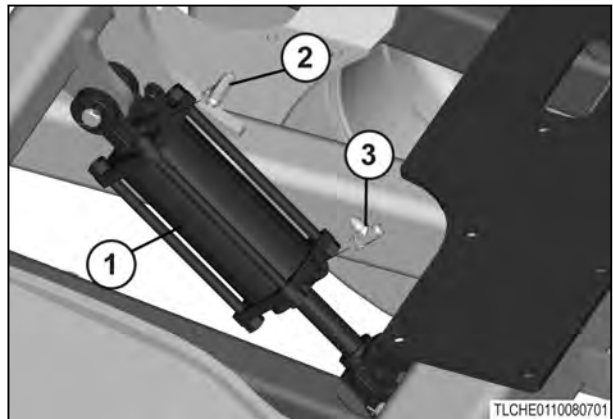

Fig. 147

6. Install the two 8MB-8MJ-90 adapters (1) (2) in the outer cylinders (3).

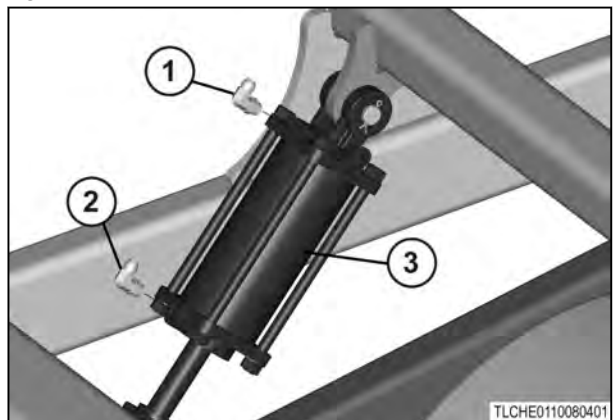

Fig. 148

7. Install the 8MJ-8MJ-8MB adapter (1) in the upper part of the inner cylinders (2). Install the 8MB-8MJ-8MJ adapter (4) with the 8MB-8MJ-90 adapter (3) on top and install in the lower part of the inner cylinders (2).

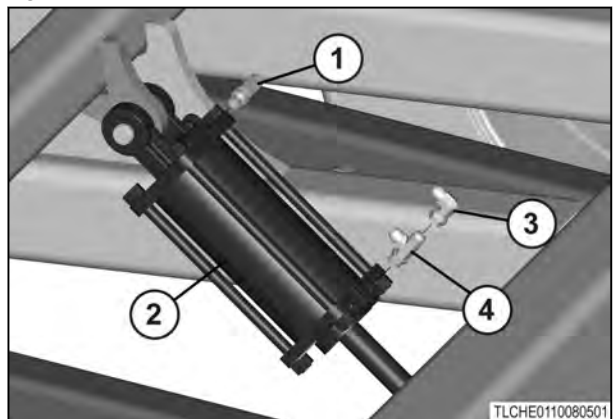

Fig. 149



8. Install the lockout valve bracket (2) to the main frame (3) with the two 3/4 x 1-1/2 bolts (1) and the 3/4 lock nuts (4).

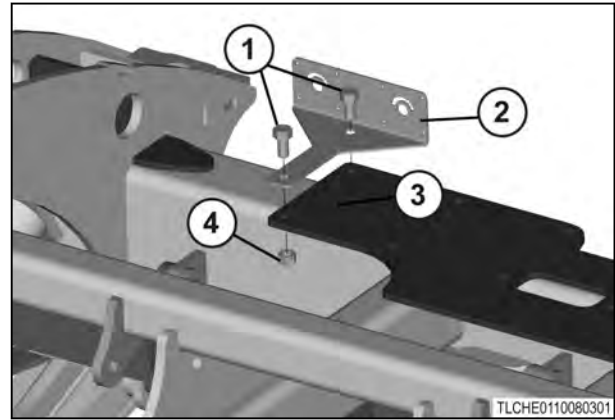

Fig. 150

9. Install the two 8MB-8MJ-90 adapters (1) to the toolbar lockout ball valve (2).

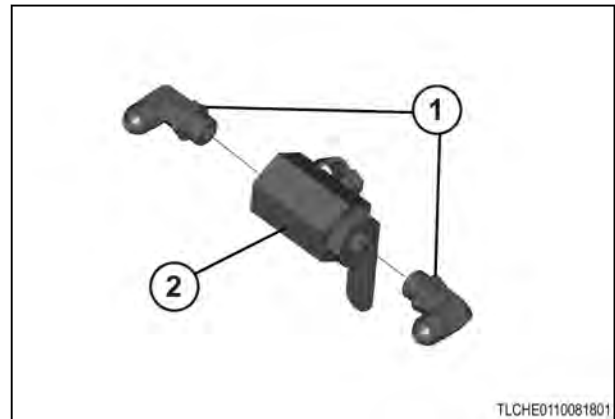

Fig. 151

10. Install the toolbar lockout valve (1) in the left-hand side of the lockout valve bracket (2). Install the handle assembly (3) on the toolbar lockout valve.

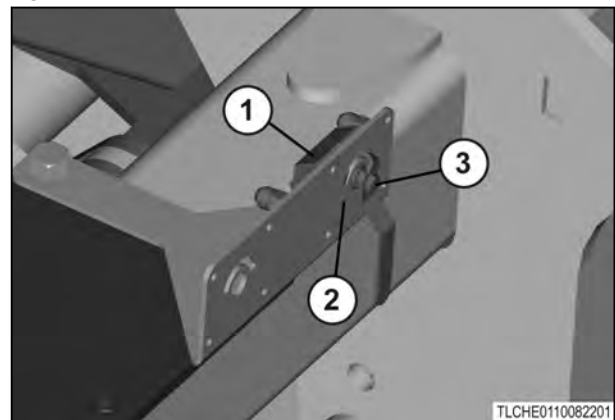

Fig. 152

11. Install the valve clamp (2) on the lockout bracket (4). Install the four 1/4 x 1-1/4 bolts (1) and 1/4 lock nuts (3).

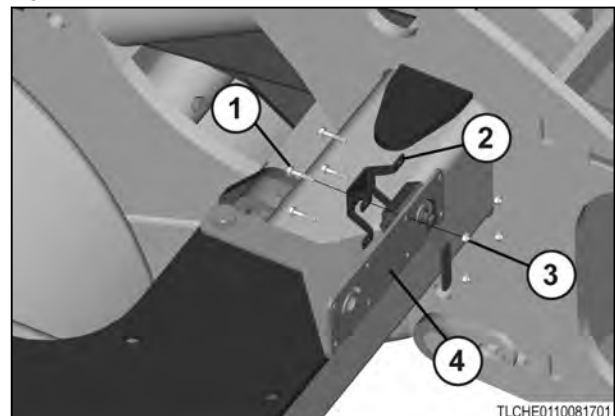

Fig. 153

- 12.** Install the down pressure valve mounting bracket (4) to the main frame (2). Install the two 1/2 x 5-1/2 x 4 x 5-1/2 U-bolts (1) and the four 1/2 lock nuts (3).

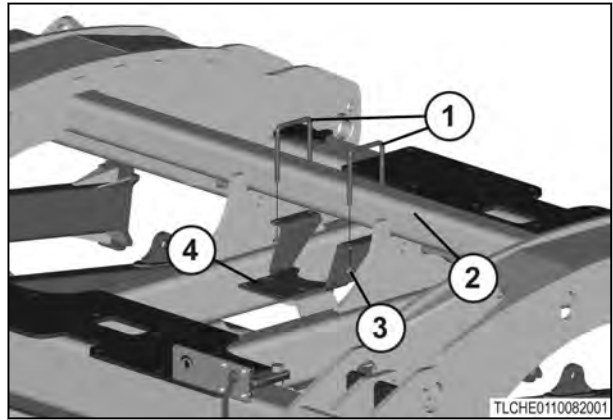

Fig. 154

- 13.** Install the two 8MB-8MJ-90 adapters (2) (3) in the ports BV1 and BV2 in the down pressure valve (1).
- 14.** Install the two 8MB-8MJ adapters and O-rings (4) (5) in the ports DPTE and DPTR.

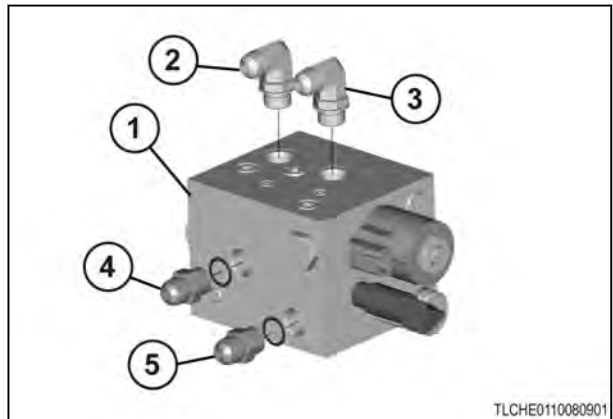

Fig. 155

- 15.** Install the four 8MB-8MJ adapters and O-rings (1) (2) (3) (4) in the ports LTCE, RTCE, RTCR, and LTRC.

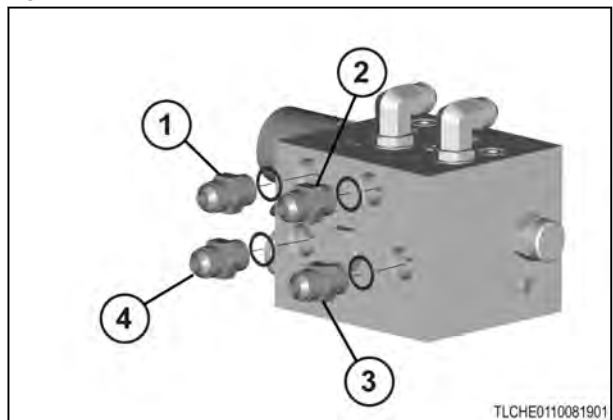

Fig. 156

- 16.** Install the transducer (2) in the port PG.

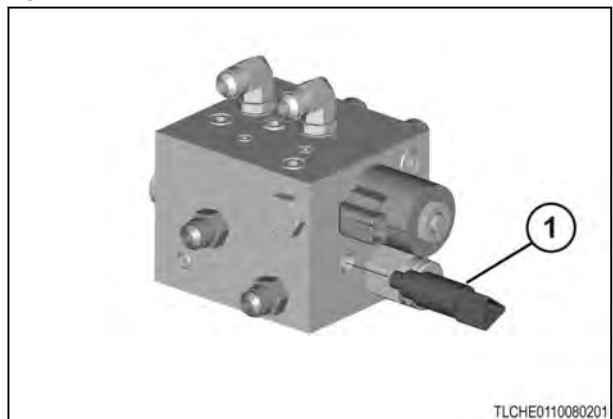

Fig. 157

17. Install the valve block (1) on the mounting bracket (3). Install the four 3/8 x 1 bolts (4) and the four 3/8 lock washers (2).

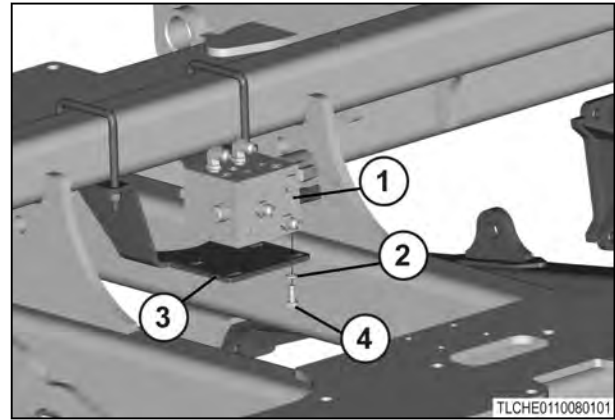

Fig. 158

18. Install the 1/2 x 23 x 8FJX-8FJX hose (6) to the adapter in port LTCE (1). Install the 8MJ-8MJ-8MB adapter (5) on the left-hand middle cylinder.
19. Install the 1/2 x 23 x 8FJX-8FJX hose (7) to the adapter in port RTCE (2) and the 8MJ-8MJ-8MB adapter (8) on the right-hand middle cylinder.
20. Install the 1/2 x 46 x 8FJX-8FJX hose (10) to the adapter in port LTCR (3) and the 8MB-8MJ-8MJ adapter (9) on the left-hand middle cylinder.
21. Install the 1/2 x 46 x 8FJX-8FJX hose (11) to the adapter in port RTCR (4) and the 8MB-8MJ-8MJ adapter (12) on the left-hand middle cylinder.
22. Install the 1/2 x 29 x 8FJX-8FJX hose (2) to the 8MB-8MJ-90 adapter (1) on the outer cylinder. Install the opposite end of the hose to the 8MB-8MJ-8MJ adapter (3) on the inner cylinder.
23. Install the 1/2 x 46 x 8FJX-8FJX hose (4) to the 8MB-8MJ-90 adapter (6) on the outer cylinder. Install the opposite end of the hose to the 8MB-8MJ-8MJ adapter (5) on the inner cylinder.

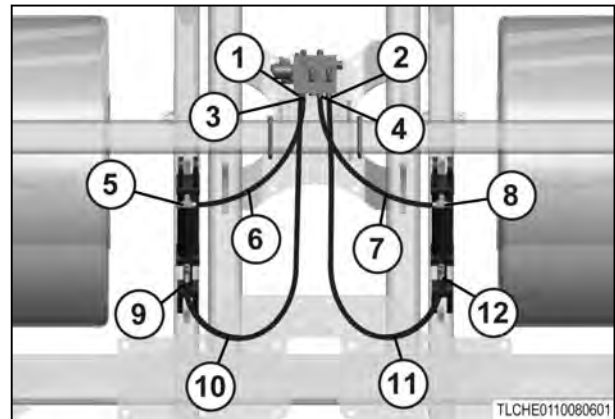

Fig. 159

**NOTE:** Repeat steps on the opposite outer cylinder.

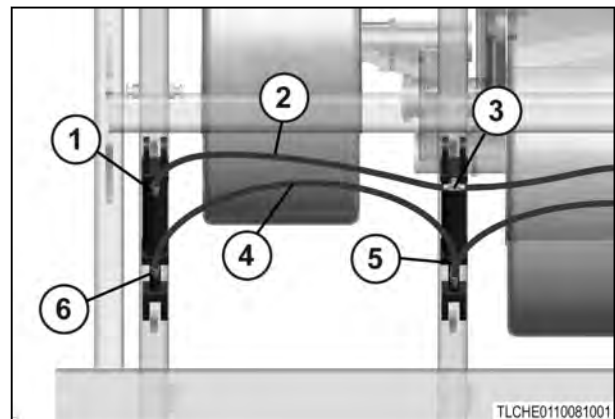

Fig. 160

24. Install the 1/2 x 29 x 8FJX-8FJX hose (2) to the 8MJ-8MJ-8MB adapter (1). Install the opposite end of the hose to the 8MJ-8MJ-8MB adapter (3) on the adjacent inner cylinder.

**NOTE:** Do not install upper hose between wing frame and main frame until a later installation.

25. Install the 1/2 x 46 x 8FJX-8FJX hose (5) to the 8MJ-8FJX-90 adapter (4). Install the opposite end of the hose to the 8MB-8MJ-8MJ adapter (3) on the adjacent inner cylinder.

**NOTE:** Repeat steps for all remaining inner cylinders.

26. Install the 1/2 x 46 x 8FJX-8FJX hose (4) to the 8MJ-8FJX-90 adapter (1). Install the opposite end of the hose to the adapter in the port DPTR (5) on the down pressure valve.
27. Install the 1/2 x 46 x 8FJX-8FJX hose (3) to the 8MJ-8FJX-90 adapter (2). Install the opposite end of the hose to the adapter in the port DPTE (6) on the down pressure valve.

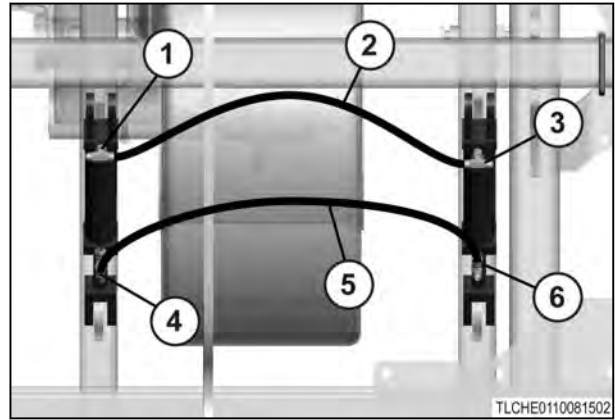

Fig. 161

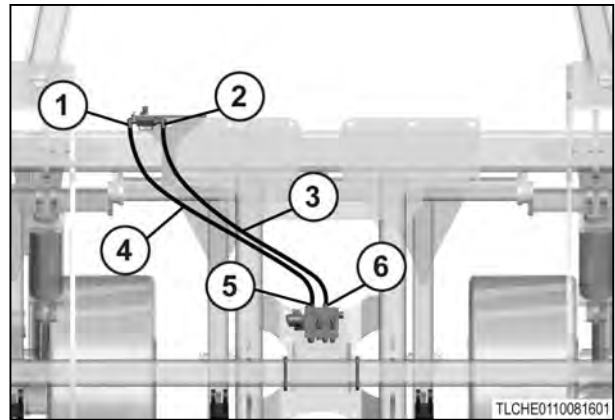

Fig. 162

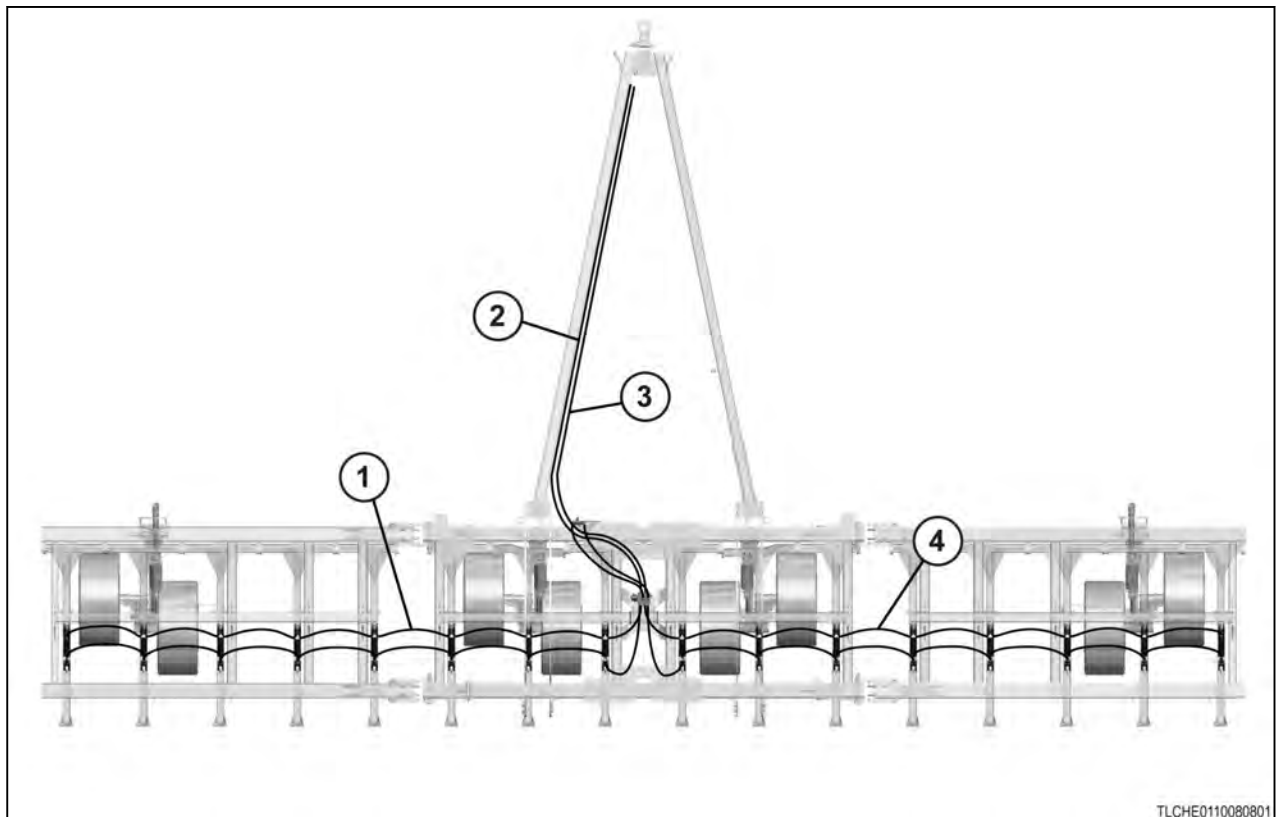

Fig. 163

28. Install the 1/2 x 32 x 8FJX-8FJX45 hoses (1) (4) between the wing frames and main frames. Install the 45° fitting to the wing frame down pressure cylinder.
29. Install the 1/2 x 306 x 8FJX-8FJX hose (2) to the adapter in port BV2, and route to utility pole on left-hand side of hitch.
30. Install the 1/2 x 306 x 8FJX-8FJX hose (3) to the adapter in port BV1, and route to utility pole on left-hand side of hitch.
31. Install the two #8 ORB male couplers (1) on the 1/2 x 306 x 8FJX-8FJX hose ends. Install the two toolbar decals (2) on the 1/2 x 306 x 8FJX-8FJX hoses.

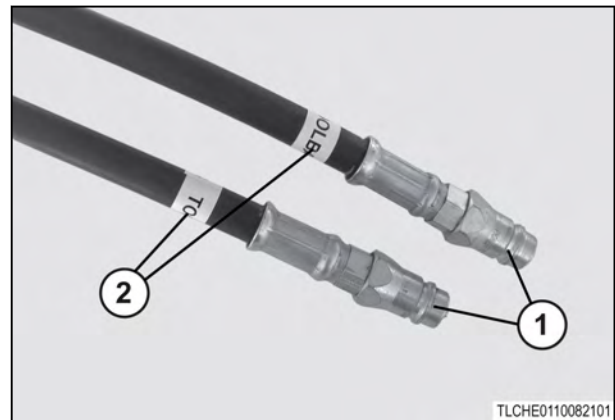

Fig. 164

### 7.7.2 Installing the wing lift hydraulics on the floating rear hitch

1. Install the cylinder mount (2) to the main frame (4). Install the eight 3/4 x 2-1/2 bolts (1), the 3/4 washers (3), and the 3/4 nuts (5).

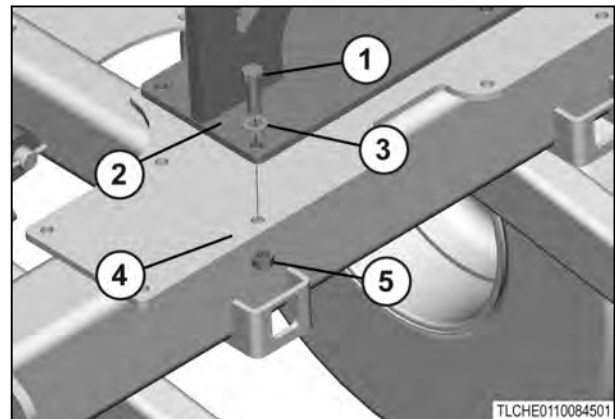
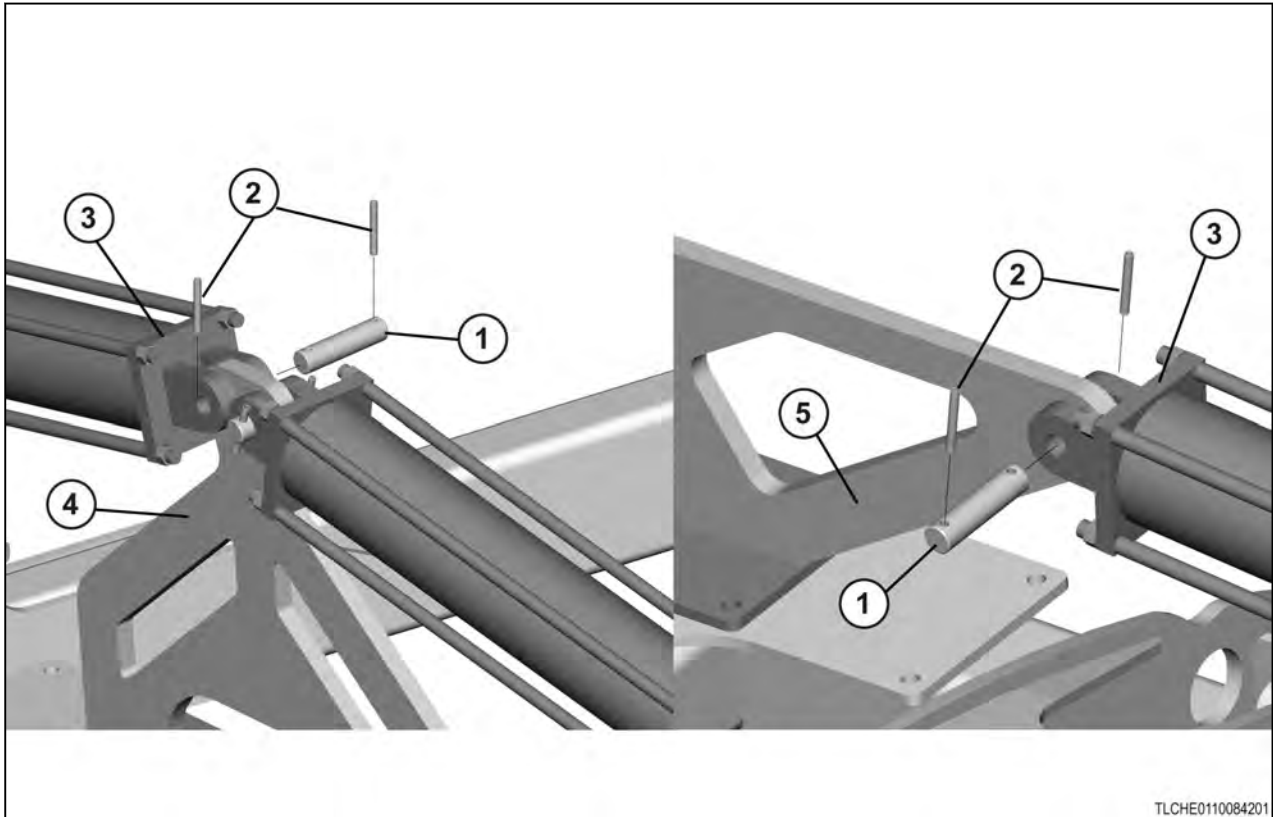

Fig. 165

2. Install two of the 8MB-8MJ-90 adapters (4) (2) in each port on the wing lift cylinders (1). Install the 8FJX-8MJX 0.090 restrictor to the 8MB-8MJ-90 adapter (4) on the piston rod end on the cylinders.



Fig. 166



TLCHE0110084201

Fig. 167

3. **NOTE:** The 30ft frame mount (4) will differ from the 40ft frame mount (5).

Align the cylinder base (3) with the cylinder mount (4) (5). Install the 1-1/4 x 6-3/8 pin (1) and the two 3/8 x 3 roll pins (2).

4. Align the cylinder piston rod (2) with the wing frame mount (5). Install the four 1-1/4 washers (3) and the 1-1/4 x 3-3/8 pin (4). Install the two 3/8 roll pins (1).

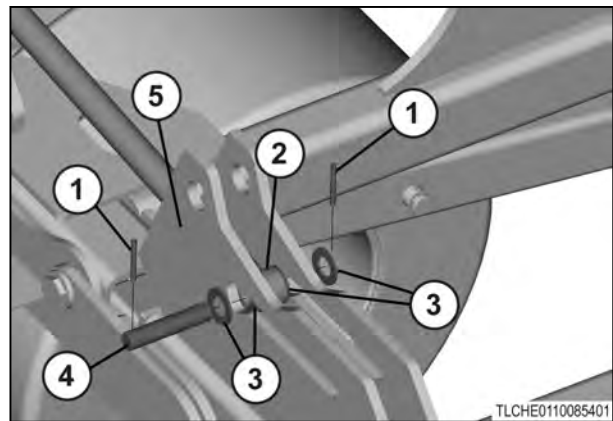

TLCHE0110085401

Fig. 168

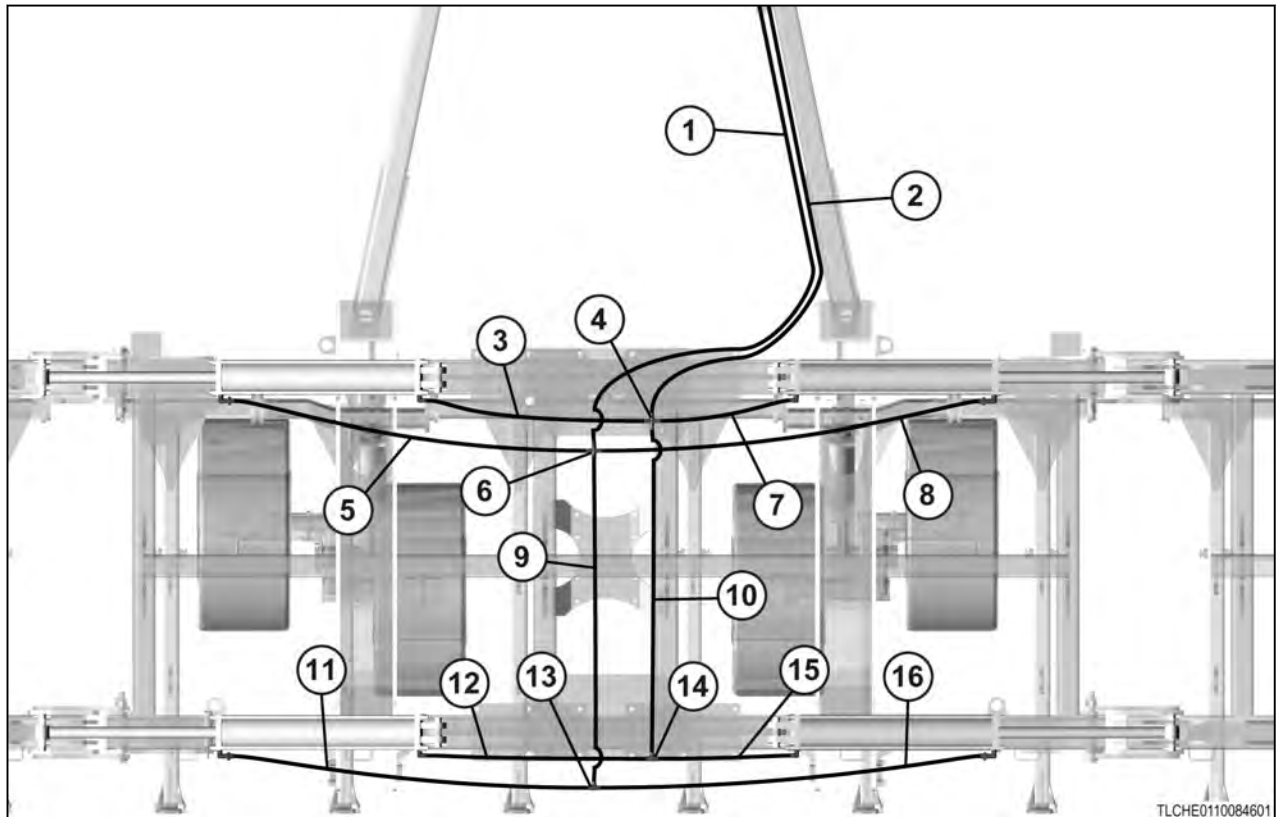

Fig. 169

5. Install the 1/2 x 290 x 8FJX-8MB hose (1) to the 8MJ adapter (6) and route along right-hand drawpole.
6. Install the 3/8 x 83 x 8FJX-8FJX hose (5) to the 8MJ adapter (6) and the front left-hand cylinder.
7. Install the 3/8 x 48 x 8FJX-8FJX hose (9) to the 8MJ adapter (6) and the 8MJ-8MJ-8MJ adapter (13).
8. Install the 3/8 x 83 x 8FJX-8FJX hose (11) to the 8MJ-8MJ-8MJ adapter (13) and the rear left-hand cylinder.
9. Install the 3/8 x 63 x 8FJX-8FJX hose (16) to the 8MJ-8MJ-8MJ adapter (13) and the rear right-hand cylinder.
10. Install the 3/8 x 63 x 8FJX-8FJX hose (8) to the 8MJ adapter (6) and the front right-hand cylinder.
11. Install the 1/2 x 290 x 8FJX-8MB hose (2) to the 8MJ adapter (4) and route along right-hand drawpole.
12. Install the 3/8 x 48 x 8FJX-8FJX hose (3) to the 8MJ adapter (4) and the front left-hand cylinder.
13. Install the 3/8 x 48 x 8FJX-8FJX hose (10) to the 8MJ adapter (4) and the 8MJ-8MJ-8MJ adapter (14).
14. Install the 3/8 x 48 x 8FJX-8FJX hose (12) to the 8MJ-8MJ-8MJ adapter (14) and the rear left-hand cylinder.
15. Install the 3/8 x 28 x 8FJX-8FJX hose (15) to the 8MJ-8MJ-8MJ adapter (14) and the rear right-hand cylinder.
16. Install the 3/8 x 28 x 8FJX-8FJX hose (7) to the 8MJ adapter (4) and the front left-hand cylinder.

17. Install the #8 ORB male couplers (1) and decals (2) on the two 1/2 x 290 x 8FJX-8MB hoses.

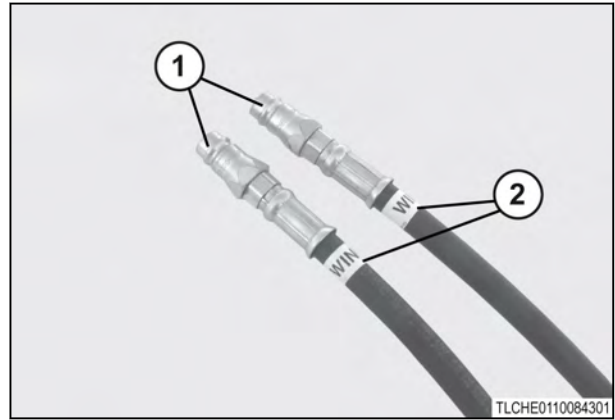

Fig. 170

### 7.7.3 Installing the floating hitch frame to the main frame

1. Install the 2-1/2 OD x 2 ID x 3 bushings (1) in the floating hitch frame (2).

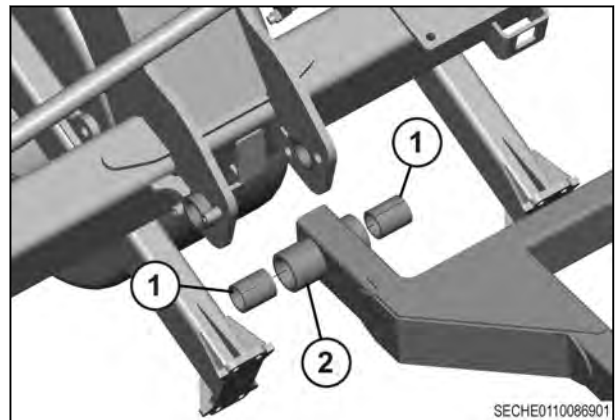

Fig. 171

2. Install the 12-1/2 x 2 flag pin (1) through the main frame hitch mount (2), the spacer (4), and the hitch frame (3).

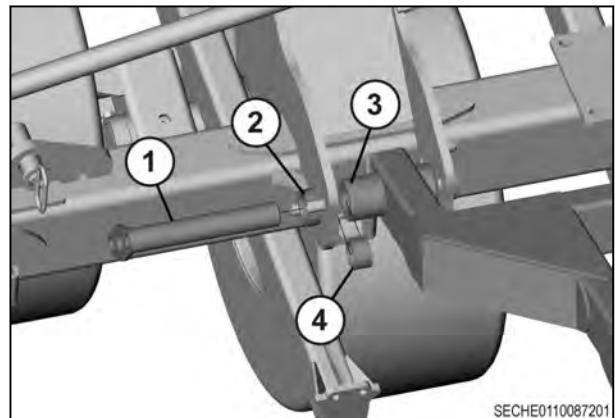

Fig. 172



3. install the flag pin (4) with the two 1/2 x 1 bolts (1), the 1/2 lock washers (3), and the 1/2 flat washer (2).

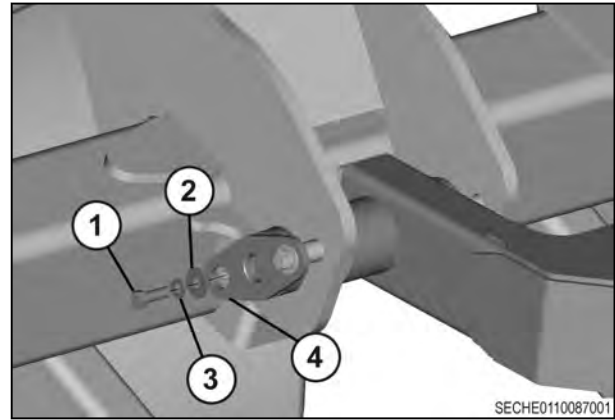

Fig. 173

4. Install the grease fitting (1) in the middle of the flag pin (2).
5. Repeat steps to install the opposite side of the hitch.

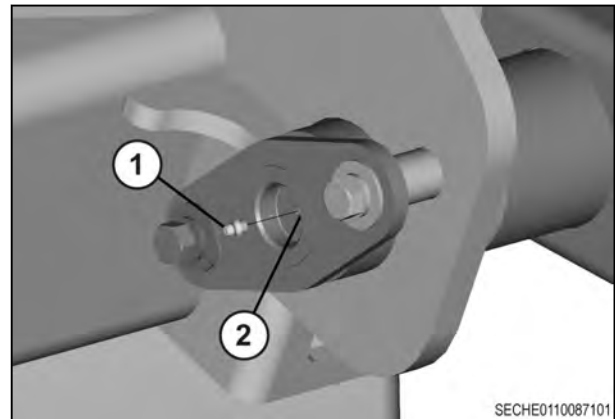

Fig. 174

#### 7.7.4 Installing the floating rear hitch wheel assembly

1. Install the rear wheel strut (3) to the floating hitch frame. Install the four 5/8 x 5-1/2 x 4 x 5-1/2 U-bolts (1) and the eight 5/8 lock nuts (2).

**NOTE:**

*Leave the nuts loose so the strut can be moved side to side.*

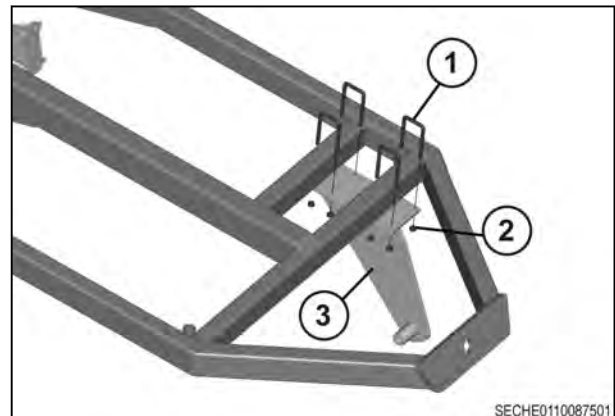

Fig. 175

2. Install the hub and spindle (4) in the rear wheel strut tube (2). Install the 1/2 x 3-1/4 bolt (1) and 1/2 lock nut (3).

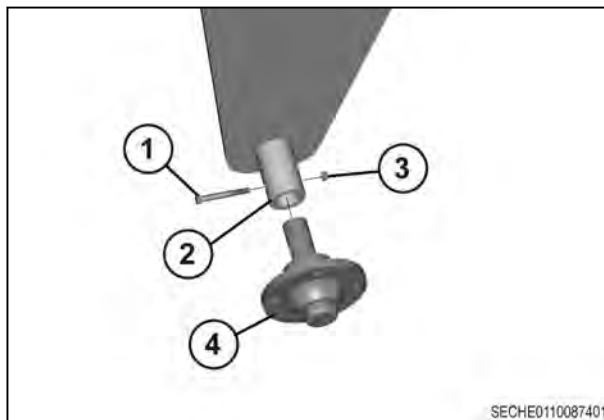

Fig. 176

3. Install the wheel (1) on the hub (2) and tighten wheel bolts. Tighten the wheel bolts to 135Nm (100 lb-ft).

**NOTE:**

*With the tire fully assembled, center the tire on the hitch and tighten the nuts fastening the wheel strut to the floating hitch frame.*

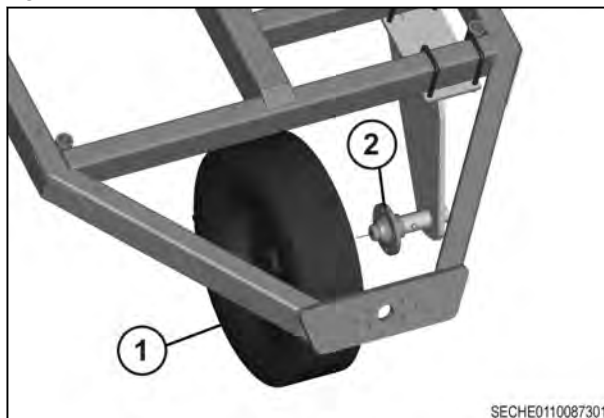

Fig. 177

### 7.7.5 Installing the bulkhead on the floating rear hitch

1. Install the bulkhead (2) to the floating hitch frame (3). Install the two 5/8 x 6 x 3 x 6 U-bolts (4) and the four 5/8 lock nuts (1).

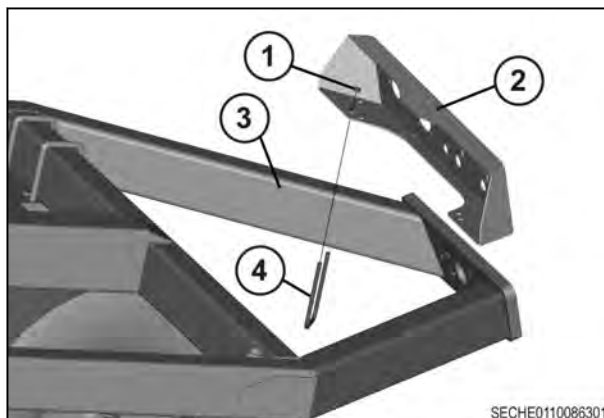

Fig. 178

2. Install the two 12MB-12MJ fittings (1) and the 10MB-10MJ fitting (2) in the front of the bulkhead (4). Connect the two 12-12 ORB female couplings (5) and the 10-10 ORB female coupling (3) to the rear side of the bulkhead (4).

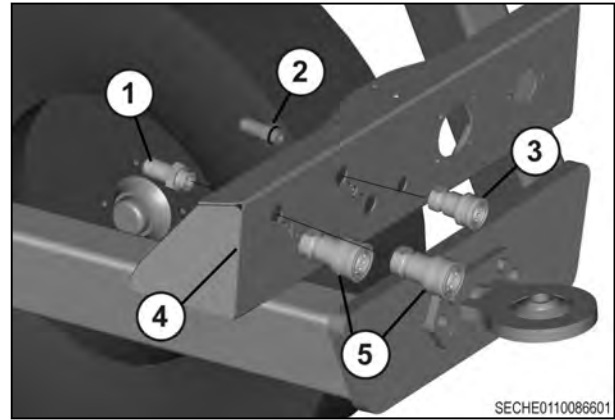

Fig. 179

3. Install the IBBC Connector (1) in the bulkhead with the four 1/4 x 1 screws (3) and the 1/4 lock nuts (2).

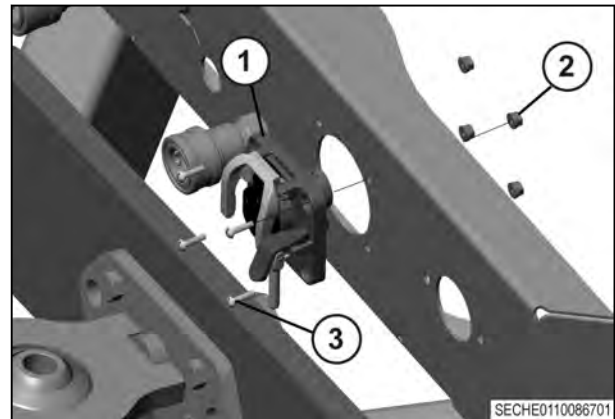

Fig. 180

4. Install the 4-3/8 clamps (4) to the frame (3) with the 3/8 x 1-1/4 bolts (2) and the 3/8 lock washer (1).

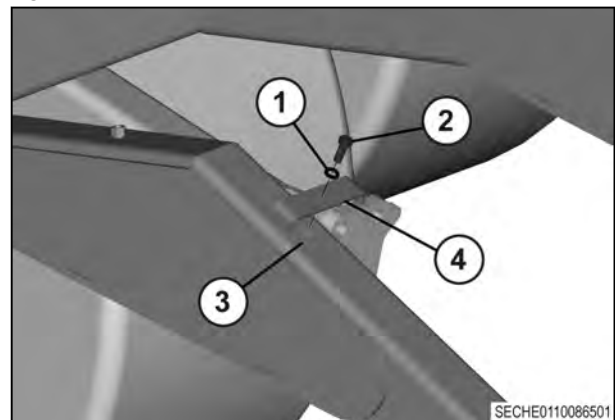

Fig. 181

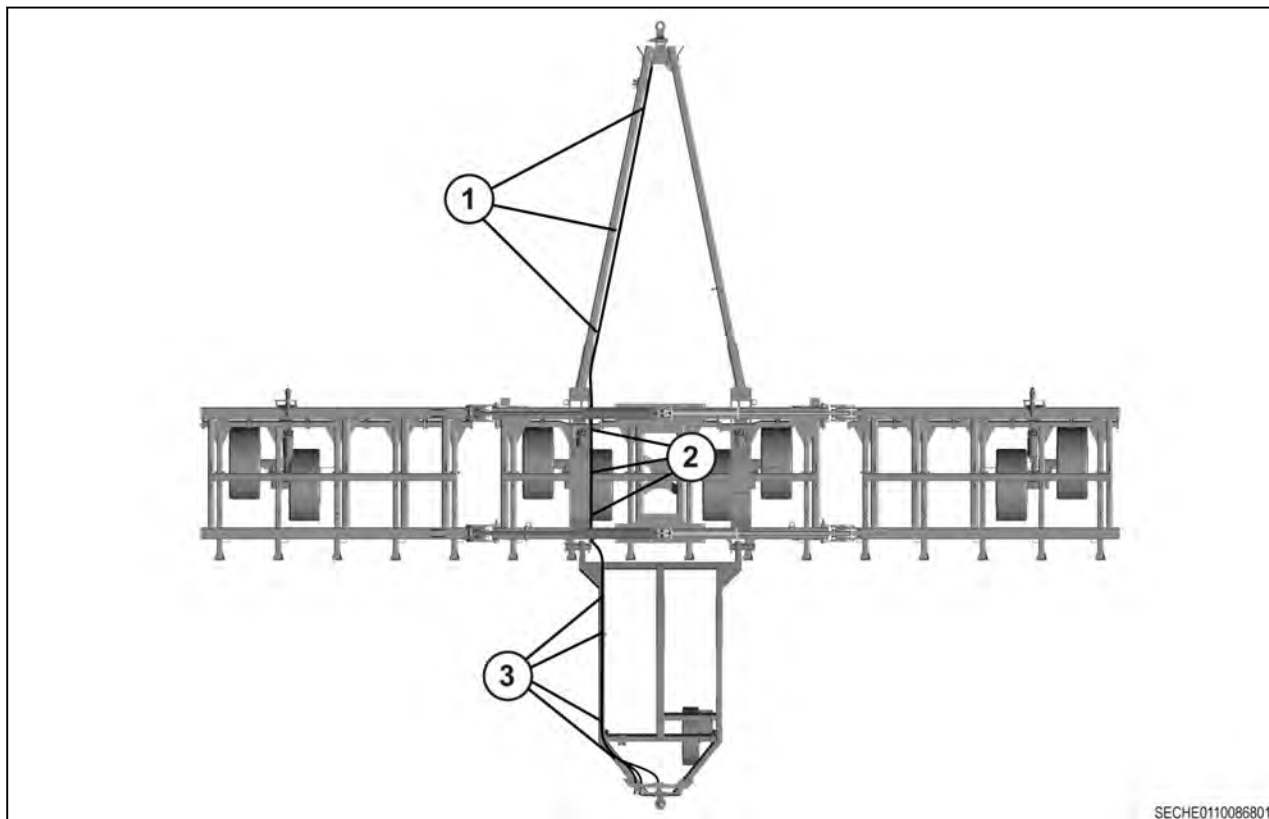

Fig. 182

5. Route hoses from bulkhead up left-hand of floating rear hitch and secure in the clamps (3). Secure hoses to the inside of the left-hand main frame and install clamps (2). Route hoses from main frame up left-hand drawpole and secure clamps (1).
6. Install the couplers on the front end of the hoses.
7. Install the pressure decal (1), the return decal (2), and the case drain decal (3) on the rear side of the bulkhead.

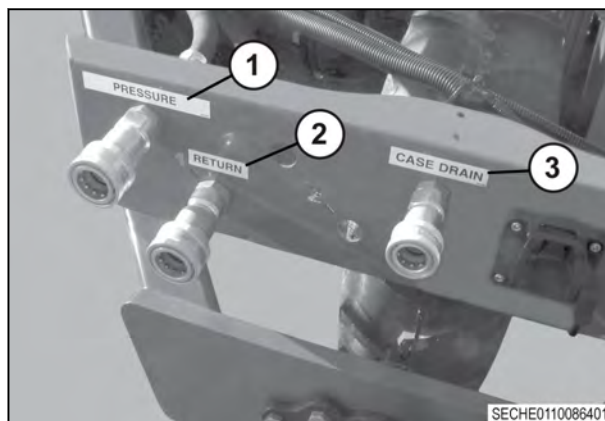

Fig. 183

### 7.7.6 Installing the rear hitch on the floating rear hitch

1. Install the hitch (3) in the floating hitch mount (4), install the rear plate (1) and secure them with the hitch nut (2).

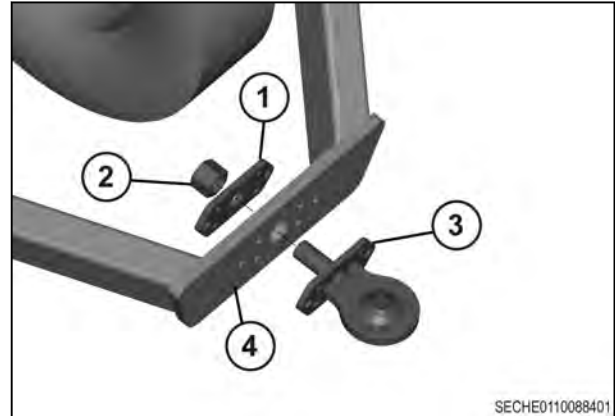

Fig. 184

2. Install hitch with the four 1/2 x 2-1/2 bolts (2) and the four 1/2 lock nuts (1). Tighten the bolts to 155 to 175 Nm (115 to 130 lbf-ft).

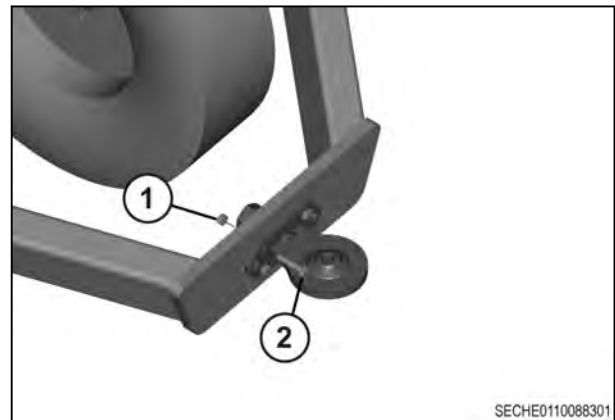

Fig. 185

### 7.7.7 Installing the rolling mount flow divider on the floating rear hitch

1. Remove the bottom assembly (1) by removing the four flange nuts (2).



Fig. 186

2. Install the top assembly (1) on the center beam. Install the bottom assembly (4) to the top assembly with the four flange nuts (3) and the four rollers (2).

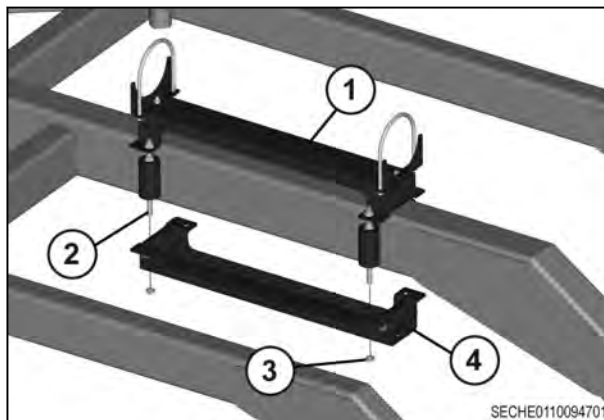

Fig. 187

3. Install the 5 inch flow divider (2) on the roller assembly (3) with the two 3/8 x 5 x 3/8 round U-bolts (1) and the four 3/8 flange nuts.

**NOTE:**

*If 6 inch flow divider is used, use two 3/8 x 6 x 3/8 round U-bolts.*

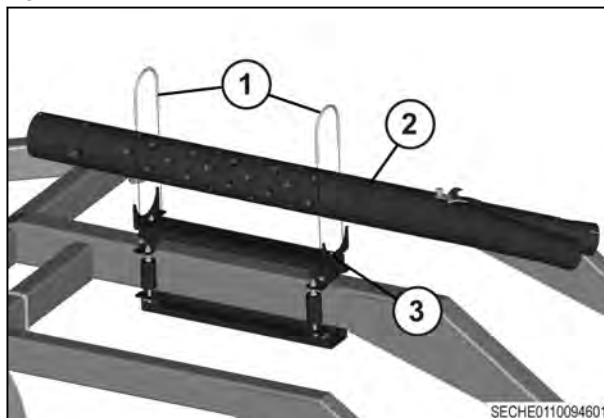

Fig. 188

### 7.7.8 Installing the down pressure harness on the floating rear hitch

1. Connect the down pressure harness to the solenoid (1) and the transducer (2) on the down pressure flow divider.

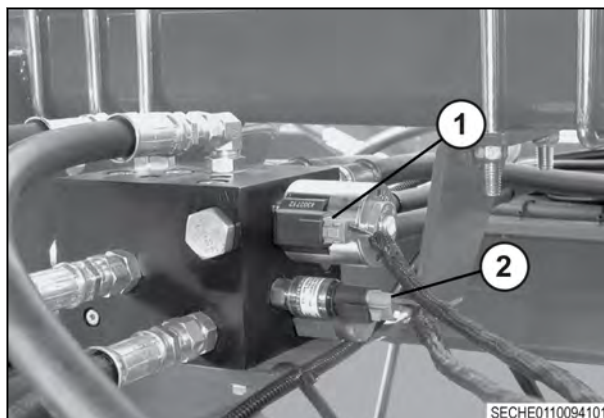

Fig. 189

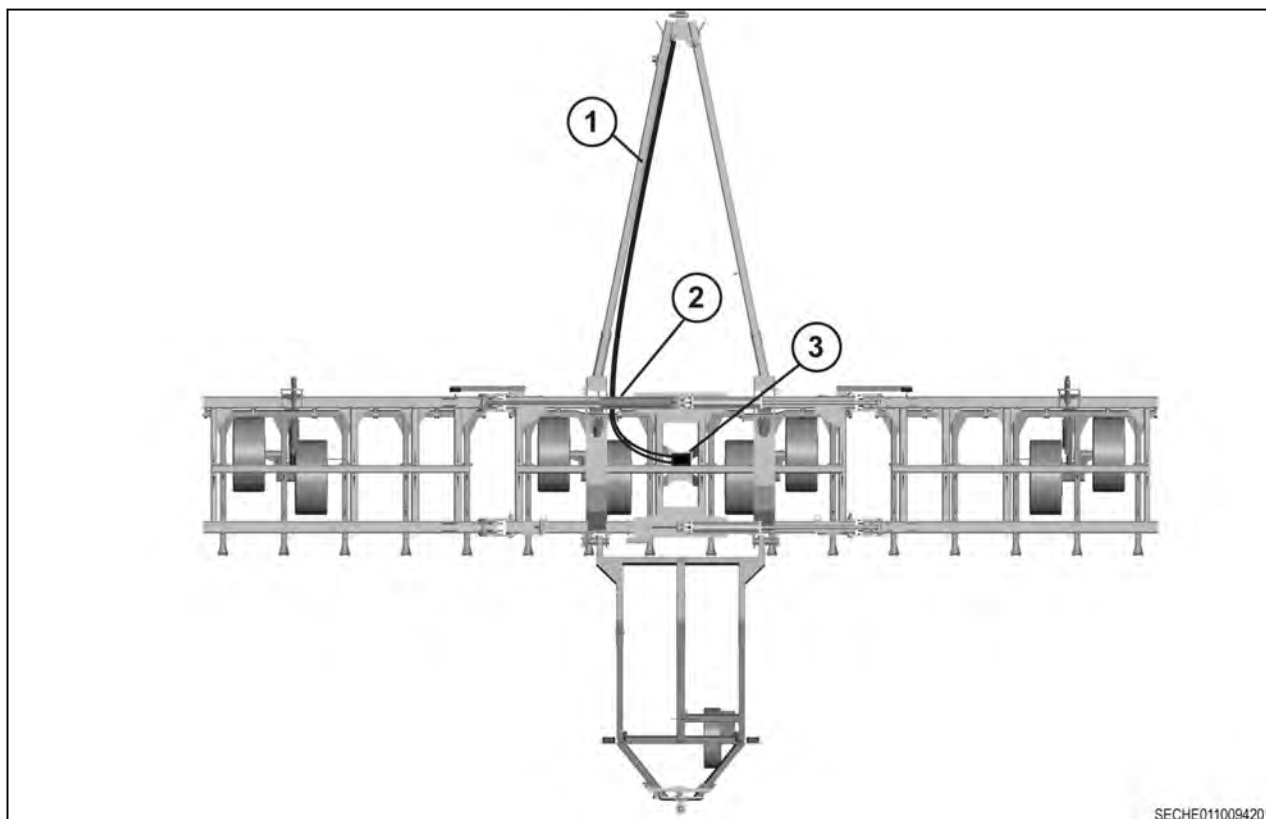

Fig. 190

2. Route the harness from the flow divider (3) along the left-hand main frame (2) and up the left-hand drawpole (1).

### 7.7.9 Installing the marker lamps and harness on the floating rear hitch

1. Install the lamp mount tube (1) in the frame mount (2).

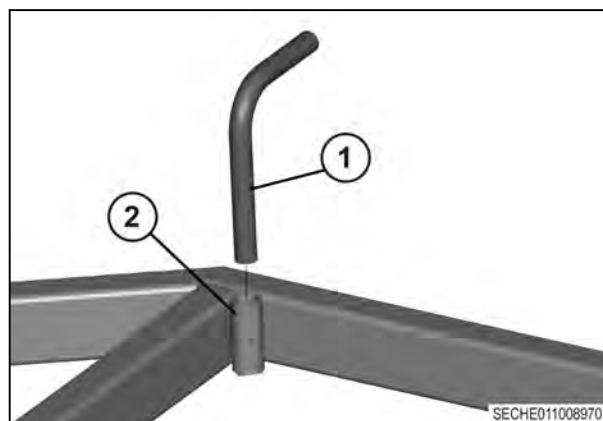

Fig. 191

2. Install the set screw (3) and the lock washer (2) in the frame mount (1).

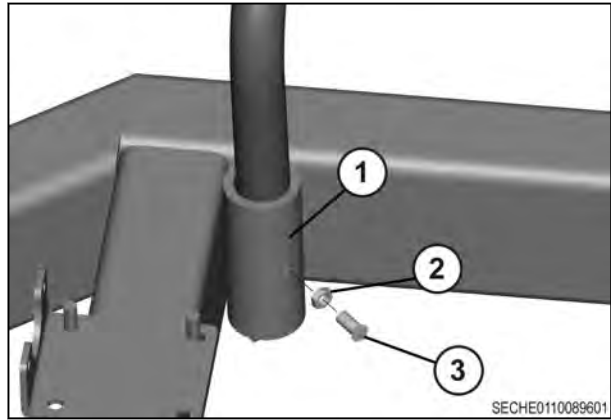

Fig. 192

3. Install the lamp bracket (2) on the lamp mount tube (1).

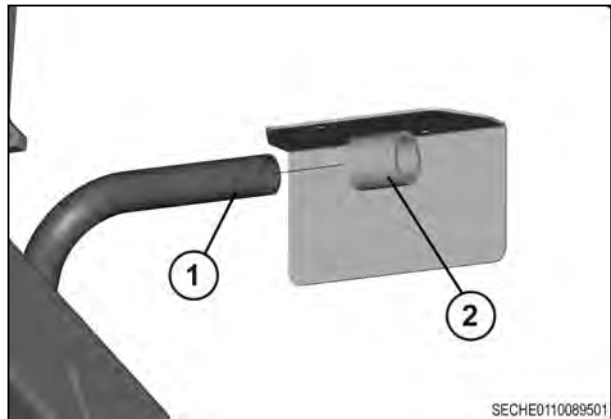

Fig. 193

4. Install the set screw (3) and the lock washer (2) in the lamp bracket (1).

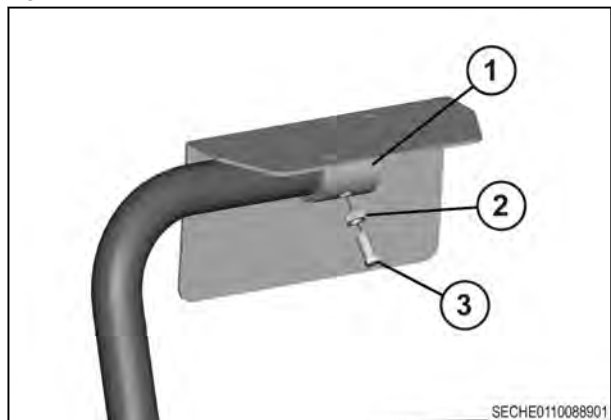

Fig. 194

5. Install the red marker lamp (1) on the lamp bracket (3) with the two 1/4 x 1 bolts (5), the two 1/4 lock washers (4), and the two 1/4 lock nuts (2).

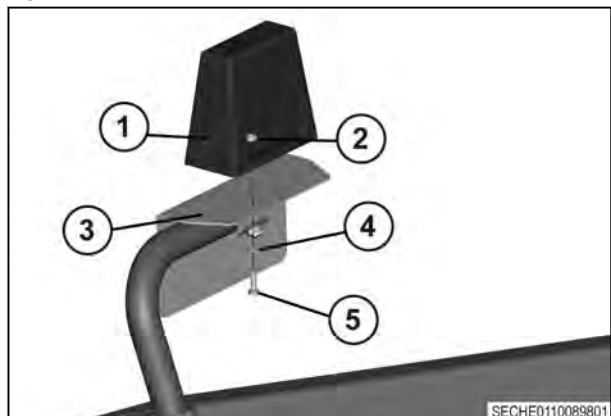

Fig. 195



6. Install the yellow reflective decal (1) to the front side of the light mount.

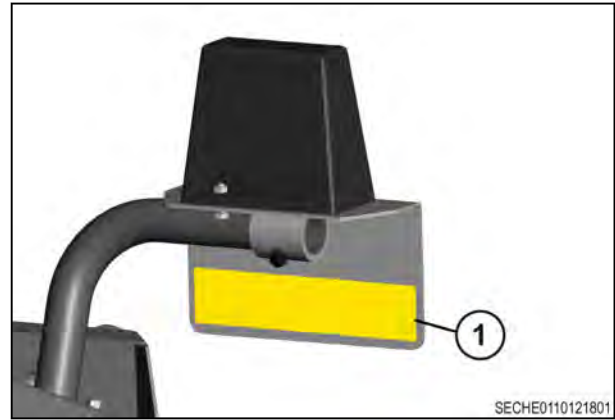

Fig. 196

7. Install the orange reflective decal (1) and the red reflective decal (2) to the back side of the light mount.

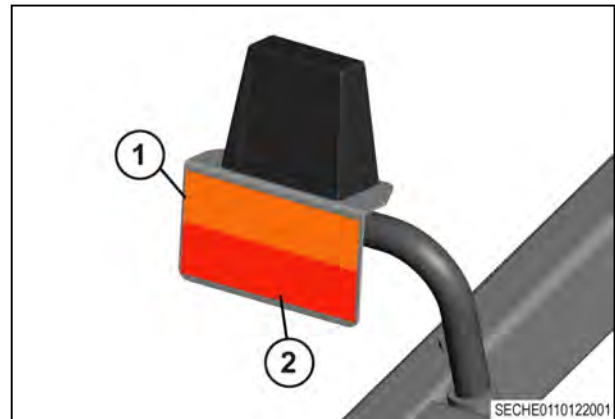

Fig. 197

8. Install the SMV sign bracket (2) to the hitch frame. Install the  $3/8 \times 5-1/2 \times 4 \times 5-1/2$  U-bolt (1) and the two  $3/8$  lock nuts (3).

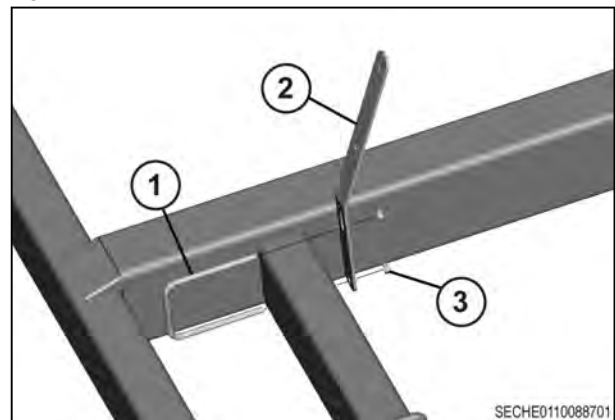

Fig. 198

9. Install the SMV sign (4) to the sign bracket (3) with the two  $1/4 \times 3/4$  bolts (1) and the two  $1/4$  lock nuts (2).

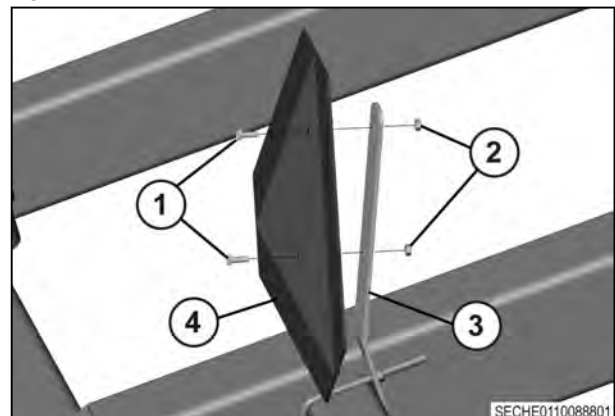

Fig. 199

10. Install the amber marker lamp bracket (1) to the main frame mount (3). Install the two 1/2 x 1 bolts (2) and the 1/2 lock nuts (4).

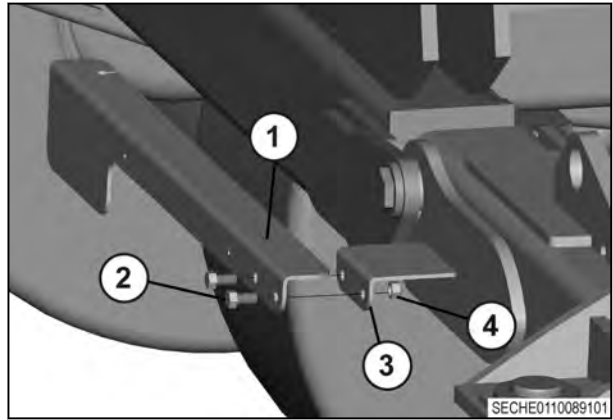

Fig. 200

11. Install the amber marker lamp (1) to the marker lamp bracket (2) with the mounting nut (3).

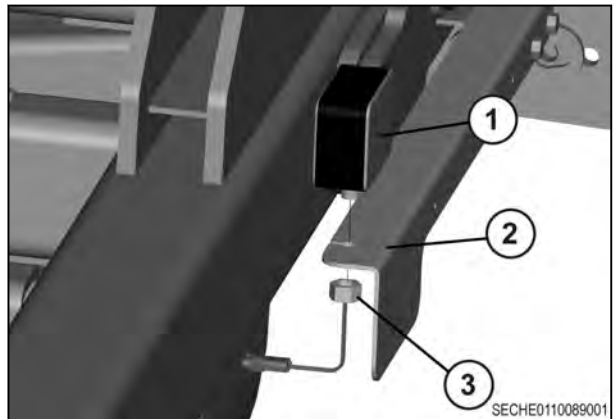

Fig. 201

12. Install the yellow reflective decal (1) to the front side of the light mount.

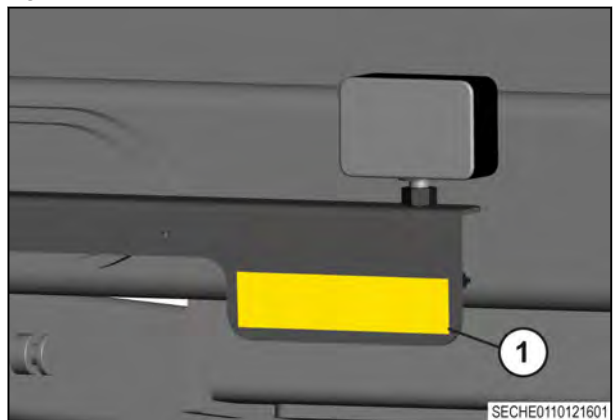

Fig. 202

13. Install the orange reflective decal (1) and the red reflective decal (2) to the back side of the light mount.

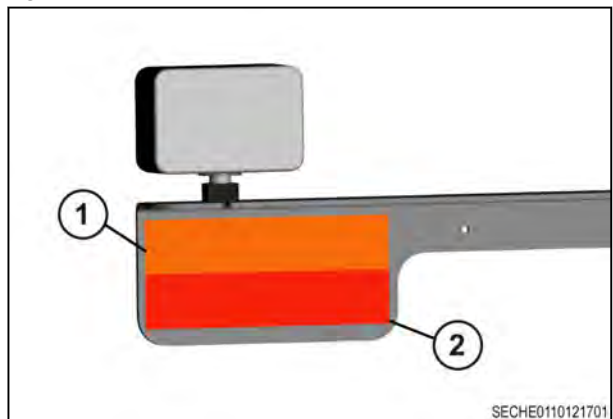

Fig. 203

14. Install the bracket mount (3) and backing plate (2) to the main frame. Install the two  $3/8 \times 7-1/2$  bolts (4) and the two  $3/8$  lock nuts (1).

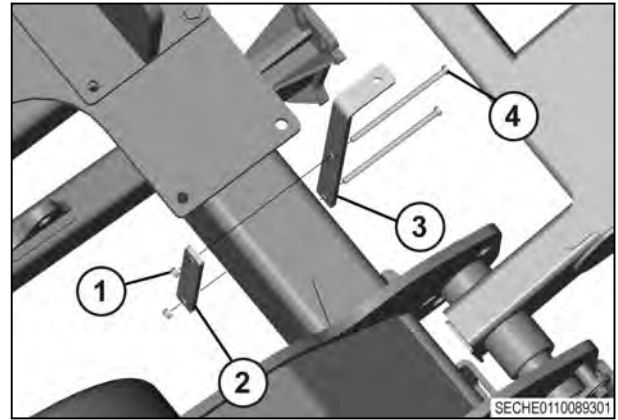

Fig. 204

15. Install the interface module bracket (2) to the bracket mount (3). Install the  $3/4 \times 1-1/4$  bolt (1) and the  $3/4$  lock nut (4).

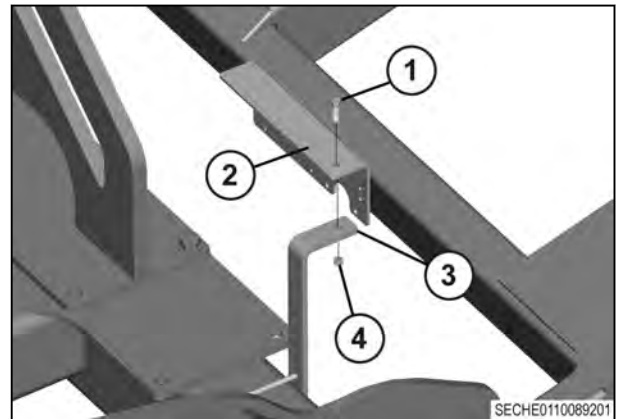

Fig. 205

16. Install the interface module (2) to the mounting bracket (3). Install the four  $3/16 \times 3/4$  screws (1) and the  $3/16$  nuts (4).

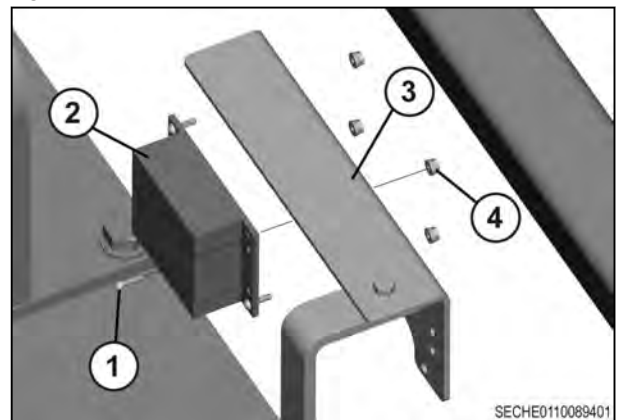

Fig. 206

17. Remove the cover (1) from the rear lamp harness.

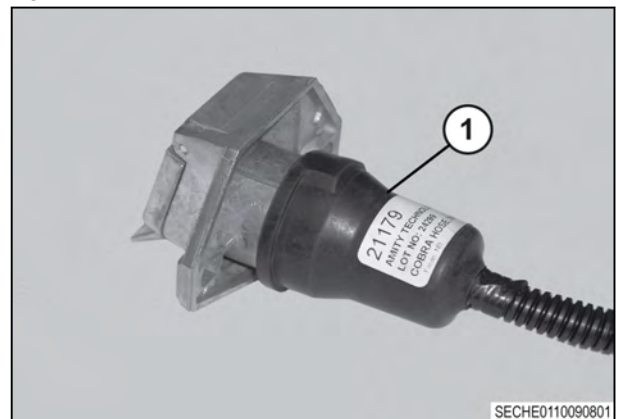

Fig. 207

18. Remove the set screw (1) from the harness connector.

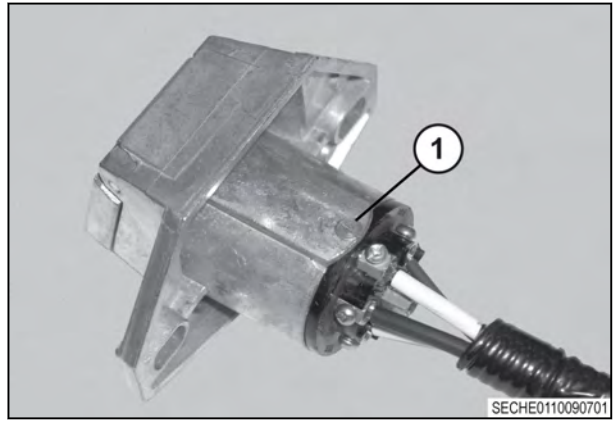

Fig. 208

19. Remove the male pins (1) from the connector.

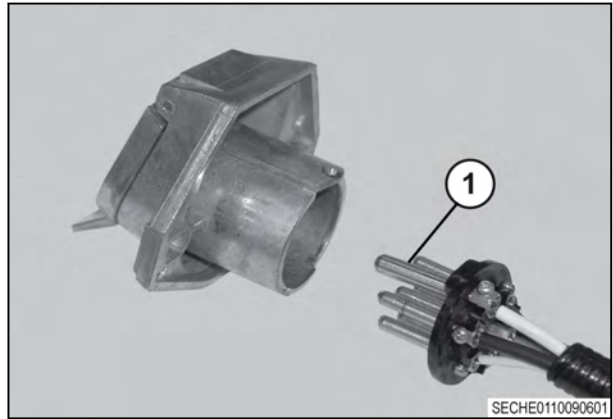

Fig. 209

20. Install the connector (1) to the bulkhead with the two 3/8 x 1 bolts (2) and the 3/8 lock nuts.

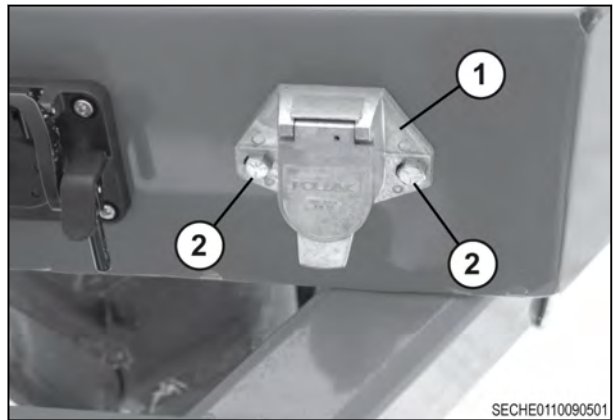

Fig. 210

21. Install the male pins (2) in the connector housing and replace the set screw (1).

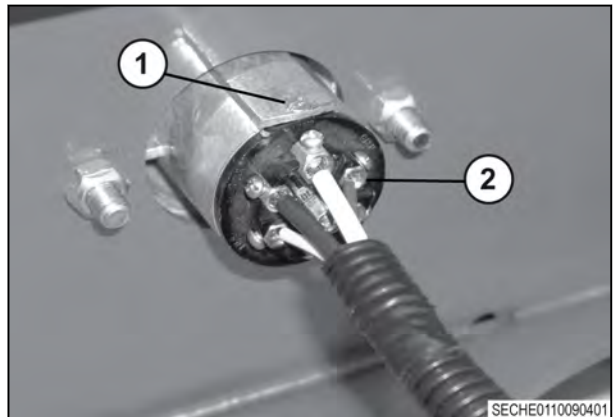

Fig. 211

22. Replace the cover (1) on the back of the connector.

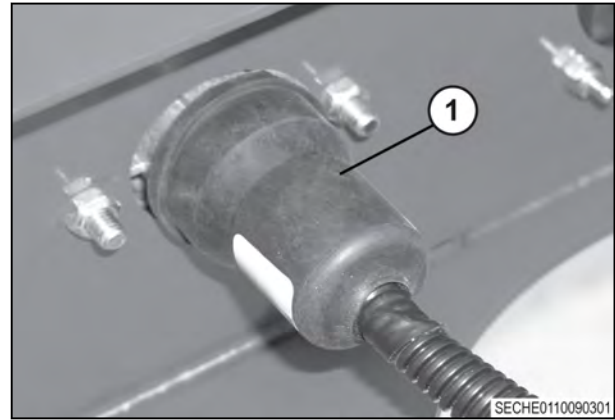

Fig. 212

23. Install the front marker lamp harness (1) to the mounting bracket with the 3/8 x 1 bolts (2) and 3/8 nuts. Connect the rear marker lamp harness (3) to the front marker lamp harness.

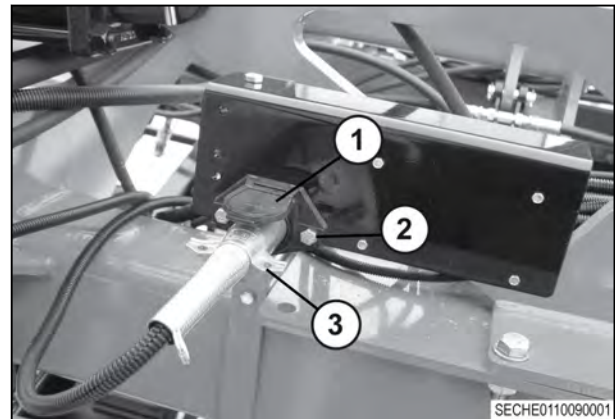

Fig. 213

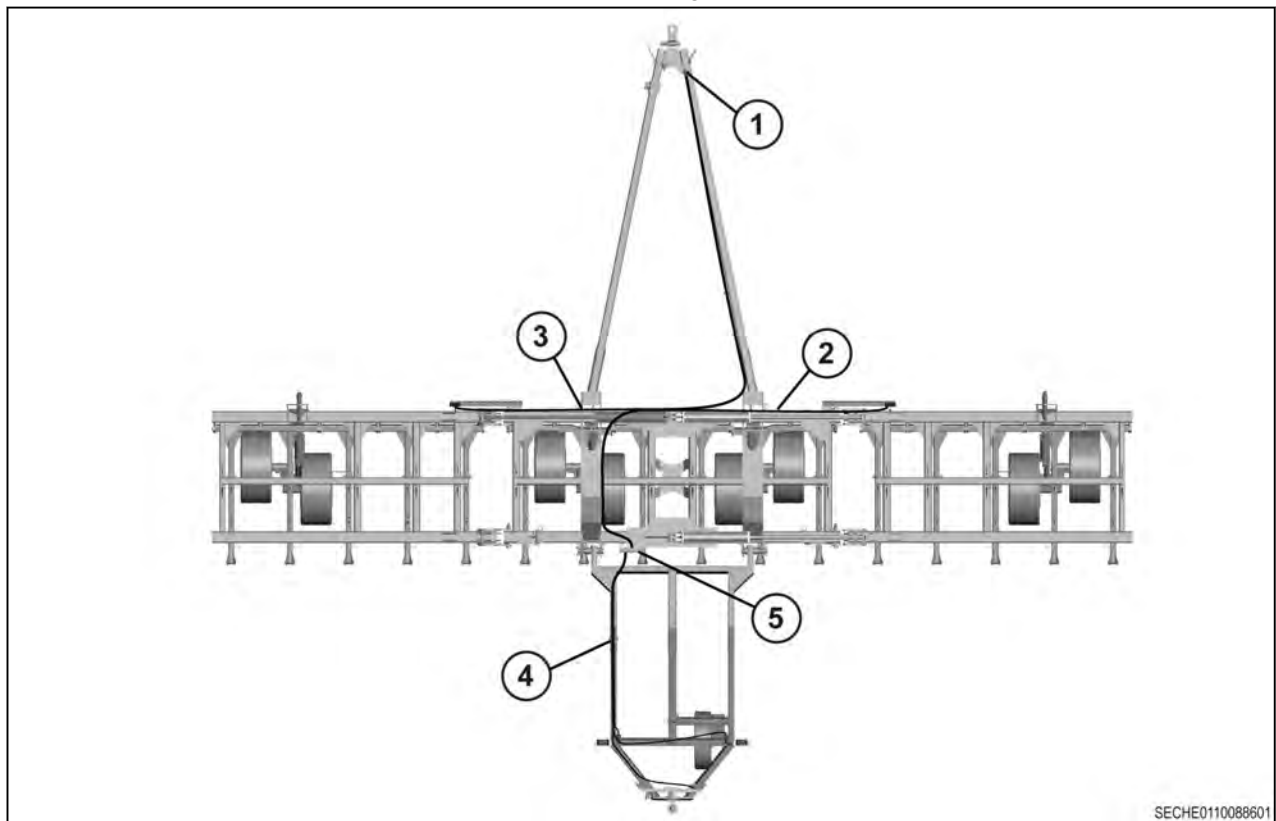

Fig. 214

24. Route the rear marker lamp harness along the left-hand side of the floating rear hitch (4) and connect to the front marker lamp harness (5).



25. Route the front harness along the left-hand main frame to the right-hand drawpole. Install the harness to the hydraulic hoses to the light socket cap (1).
26. Connect the left-hand (3) and right-hand marker lamps (2) to the front marker lamp harness and route along the front of the main frame.
27. Install all of the wires to the hydraulic hoses.

### 7.7.10 Installing the main ISO harness on the floating rear hitch

1. Connect the main ISO harness connectors (1) (2) to the IBBC connector on the bulkhead.

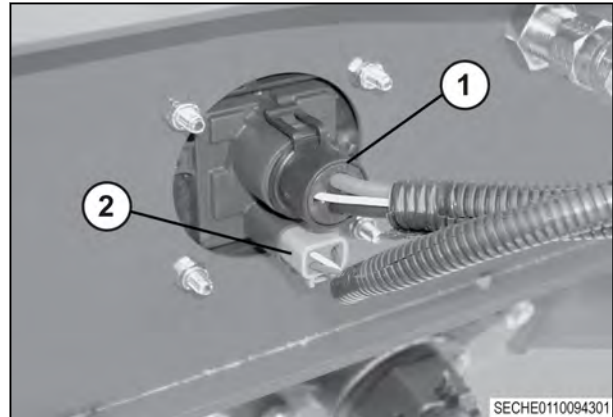

Fig. 215

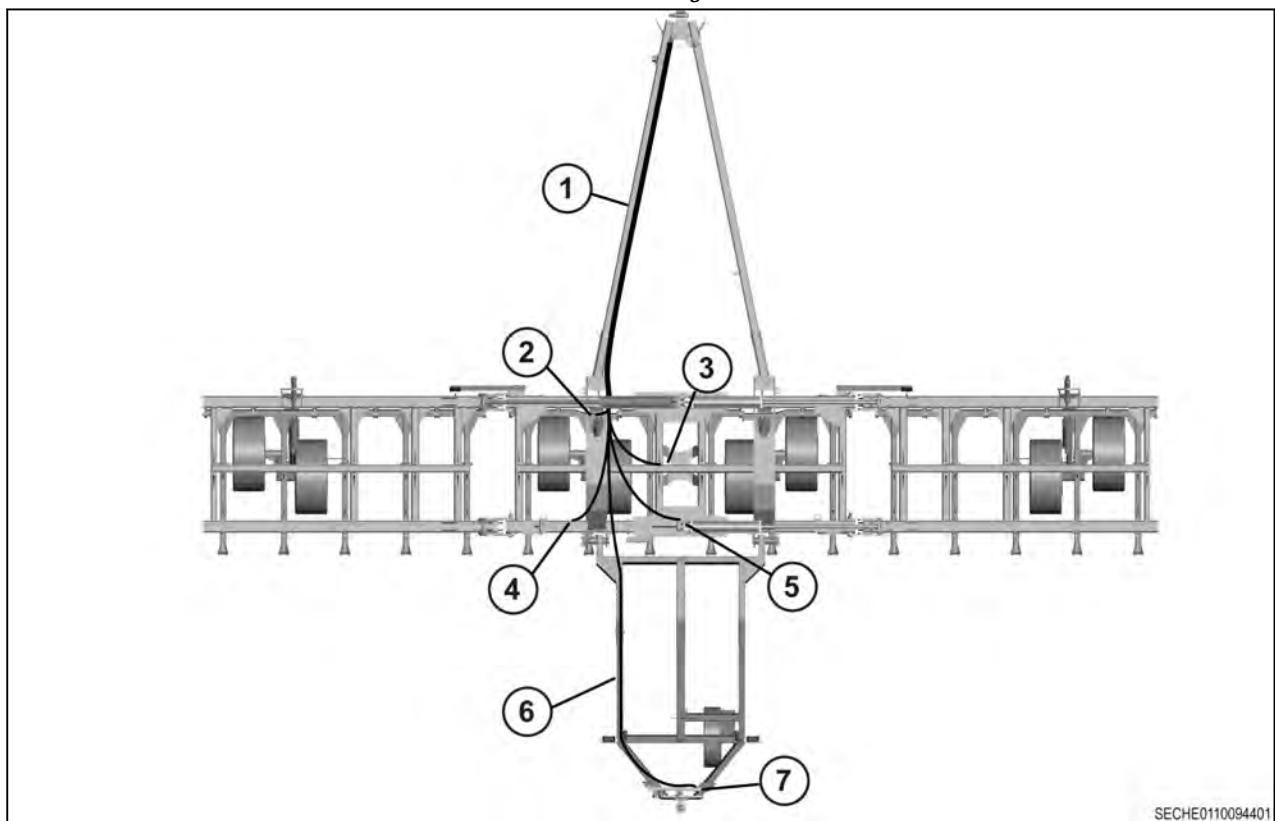

Fig. 216

2. Route the harness along the left-hand hitch frame (6) and the left-hand drawpole (1). Install the harness to the hydraulic hoses.
3. Connect the work switch harness (2).
4. Connect the NH3 module (3).
5. Connect the left-hand wireless blockage monitor harness (4).
6. Connect the right-hand wireless blockage monitor harness (5).
7. Connect the IBBC connections (7).

## 7.8 Installing the hydraulic lift assist

### 7.8.1 Installing the down pressure hydraulics on the hydraulic lift assist

1. Align the down pressure cylinder base (3) with the frame toolbar mounting bracket (2). Install the 1 x 3-3/8 pin (1).

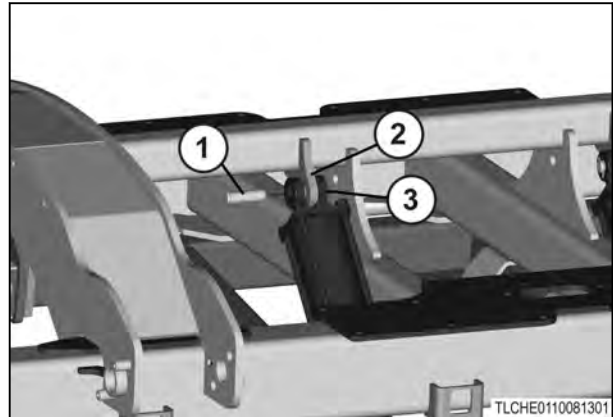

Fig. 217

2. Install the two clevis pins (1) through the 1 x 3-3/8 pin (2).

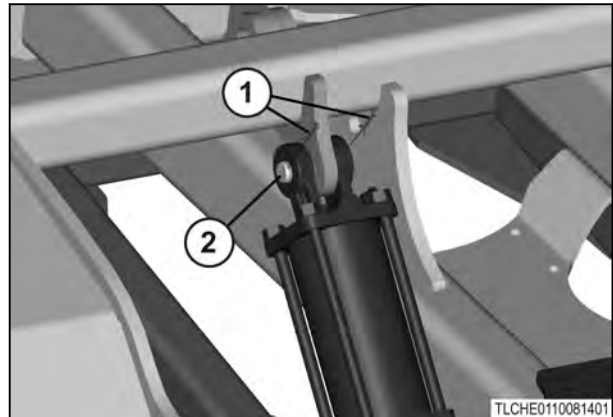

Fig. 218

3. Align the down pressure cylinder piston rod (2) with the toolbar mounting bracket (3). Install the 1 x 3-3/8 pin (1).

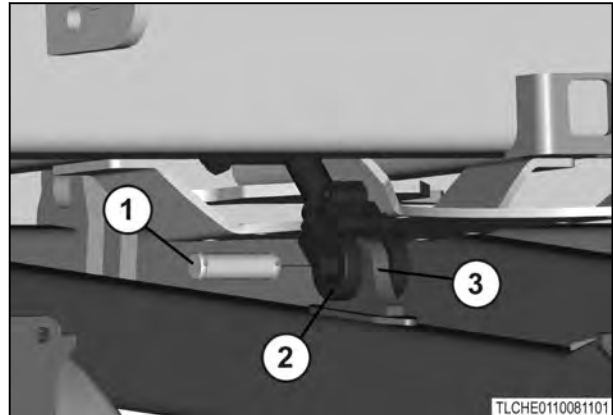

Fig. 219

4. Install the two clevis pins (1) through the 1 x 3-3/8 pin (2).  
Install all of the remaining down pressure cylinders before beginning the next step.

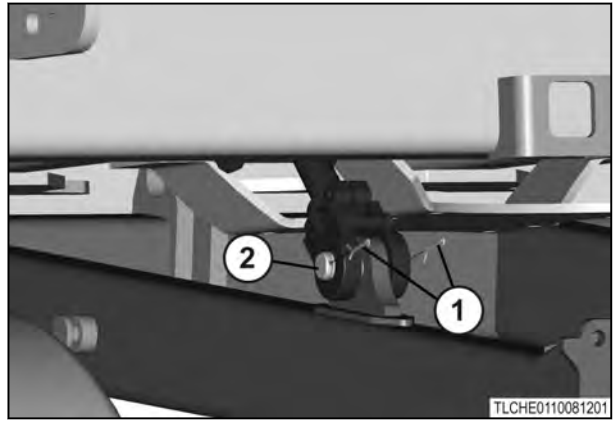

Fig. 220

5. Install the 8MJ-8MJ-8MB adapter (2) and the 8MB-8MJ-8MJ adapter (3) in the middle cylinder (1).

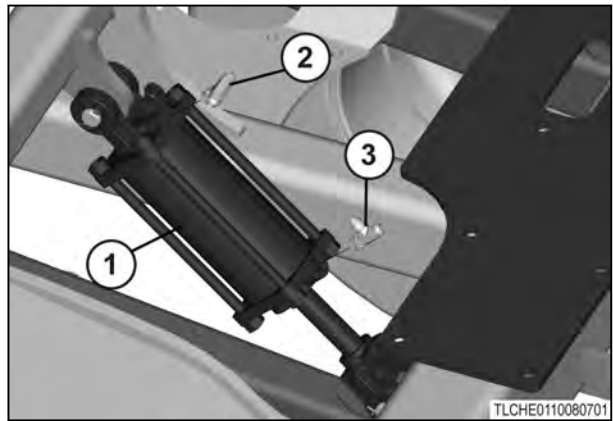

Fig. 221

6. Install the two 8MB-8MJ-90 adapters (1) (2) in the outer cylinder (3).

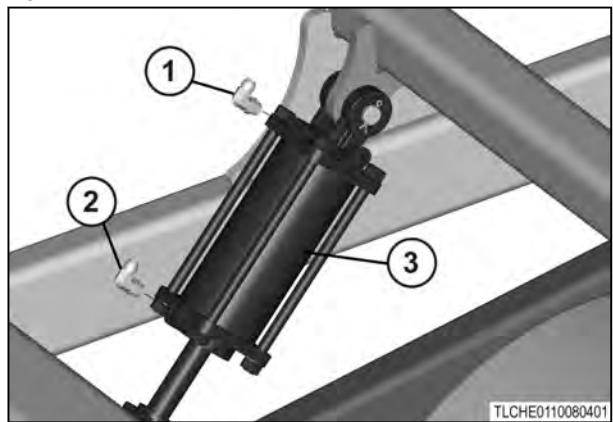

Fig. 222

7. Install the 8MJ-8MJ-8MB adapter (1) in the upper port of the inner cylinder (2). Install the 8MB-8MJ-8MJ adapter (4) with the 8MB-8MJ-90 adapter (3) install on top in the lower port of the inner cylinder (2).

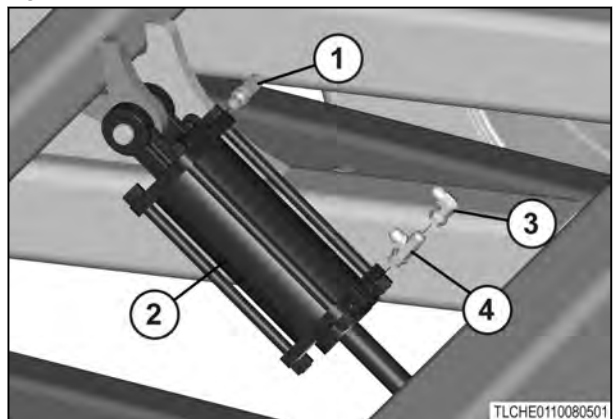

Fig. 223



8. Install the lockout valve bracket (2) to the main frame (3). Install the two 3/4 x 1-1/2 bolts (1) and the 3/4 lock nuts (4).

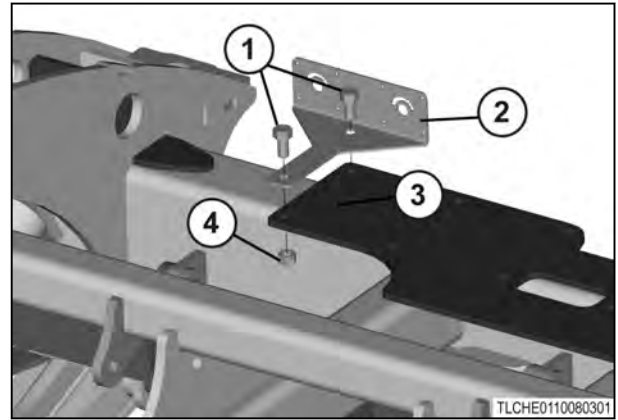

Fig. 224

9. Install the two 8MB-8MJ-90 adapters (1) to the toolbar lockout ball valve (2).

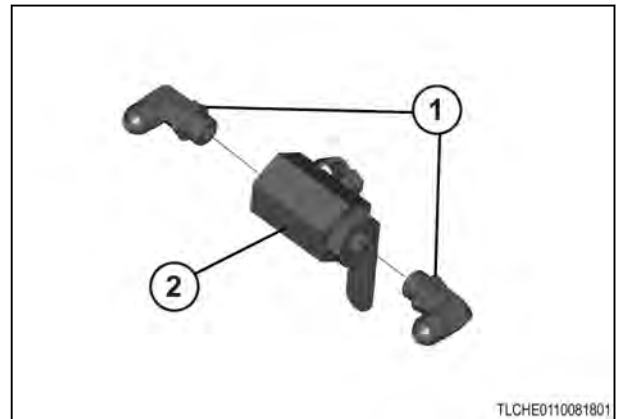

Fig. 225

10. Install the toolbar lockout valve (1) in the left-hand side of the lockout valve bracket (2). Install the handle assembly (3) on the toolbar lockout valve.

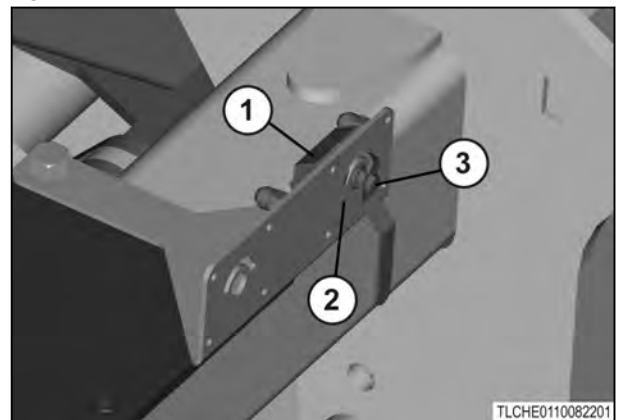

Fig. 226

11. Install the valve clamp (2) on the lockout bracket (4) with the four 1/4 x 1-1/4 bolts (1) and 1/4 lock nuts (3).

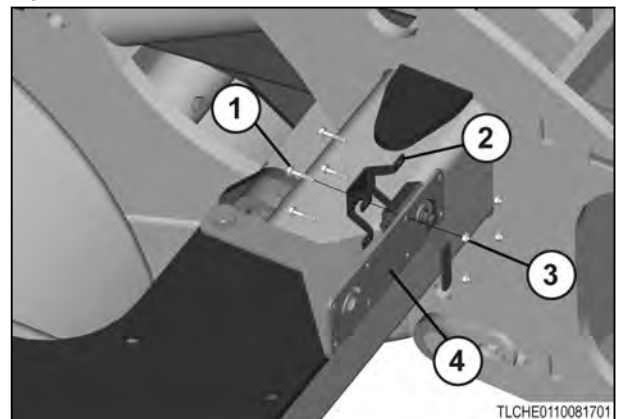

Fig. 227

- 12.** Align the down pressure cylinder (2) with the rear cylinder mount (1). Install the 1-1/4 x 5-1/4 pin (4), the two 1-1/2 washers (5), and the two 3/8 x 3 roll pins (3).

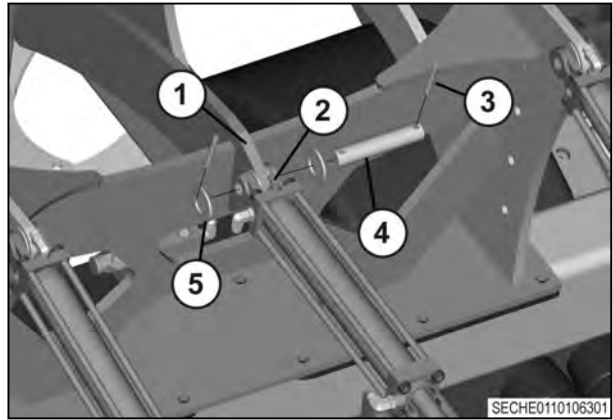

Fig. 228

- 13.** Align the down pressure cylinder (2) with the hydraulic lift assist cylinder mount (4). Install the 1-1/2 x 5-1/4 pin (5), the two 1-1/2 washers (3), and the two 3/8 x 3 roll pins (1).

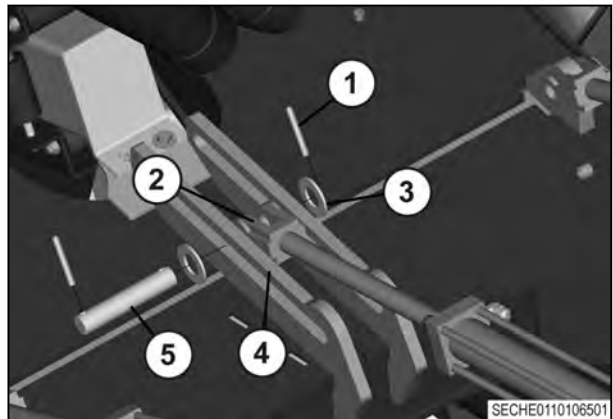

Fig. 229

- 14.** Install the two 8MB-8MJ-90 adapters (1) in the HLA down pressure cylinder (2).

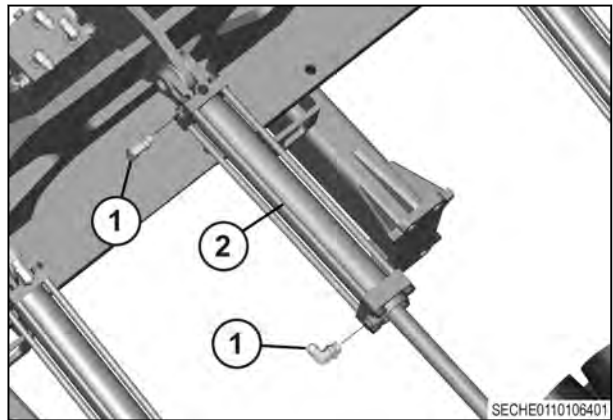

Fig. 230

- 15.** Install the 8MB-8MJ-45 adapter (1) in port DPCE on the main valve block (5).  
**16.** Install the pressure transducer (2) in port PG1.  
**17.** Install the 8MB-8MJ adapter (3) in port DRCR.  
**18.** Install the 8MB-8MJ adapter (4) in port P1.

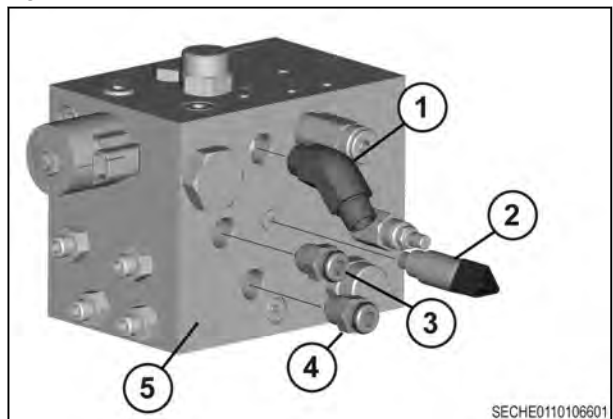

Fig. 231

19. Install the 8MB-8MJ adapter (1) in port SA.
20. Install the 10MB-10MJ adapter (2) in port DPTR on the main block valve (3).

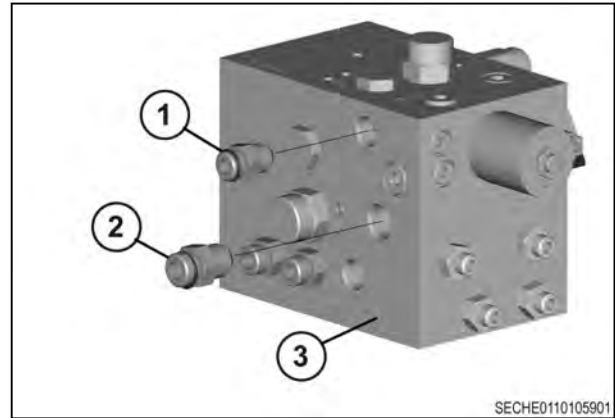

Fig. 232

21. Install the 8MB-8MJ-90 adapter (1) in port RTCR on the toolbar regeneration valve block (4).
22. Install the 8MB-8MJ-90 adapter (2) in port RTCE.
23. Install the 8MB-8MJ-90 adapter (3) in port P1.

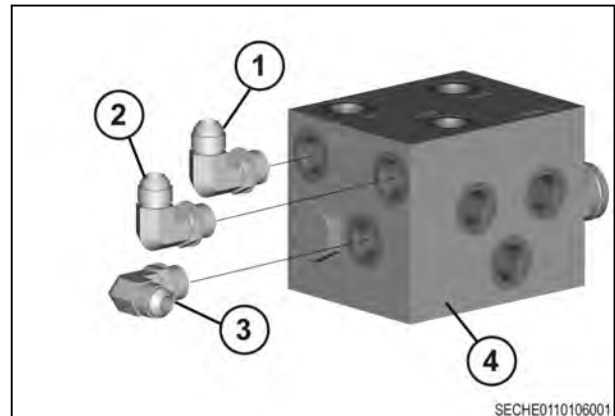

Fig. 233

24. Install the 8MB-8MJ-90 adapter (1) in port AUXR on the toolbar regeneration valve block (7).
25. Install the 8MB-8MJ-90 adapter (2) in port BV1.
26. Install the 8MB-8MJ-90 adapter (3) in port AUXE.
27. Install the 8MB-8MJ adapter (4) in port VE.
28. Install the 8MB-8MJ adapter (5) in port VR.
29. Install the 8MB-8MJ adapter (6) in port BV2.
30. Install the 8MB-8MJ-90 adapter (8) in port LTCE.
31. Install the 8MB-8MJ-90 adapter (9) in port LTCR.
32. Install the toolbar regeneration valve block (1) on the main frame (2). Install the four 3/8 x 1-1/4 bolts (4) and the four 3/8 lock washers (3).

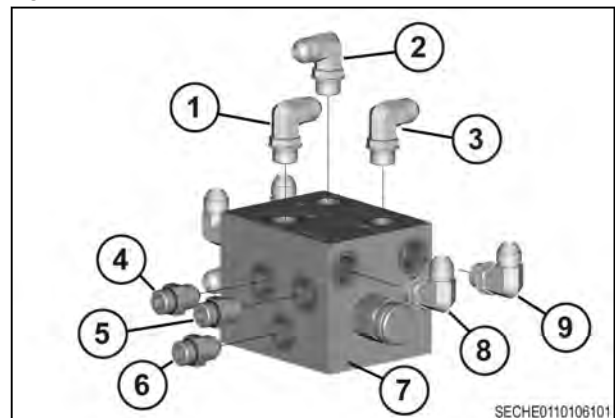

Fig. 234

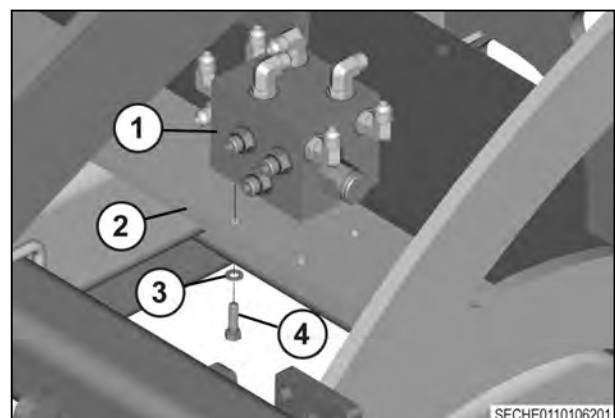

Fig. 235

33. Install the main valve mounting bracket (2) to the main frame (1). Install the two  $1/2 \times 5-1/2 \times 4 \times 5-1/2$  U-bolts (3) and the four  $1/2$  lock nuts (4).

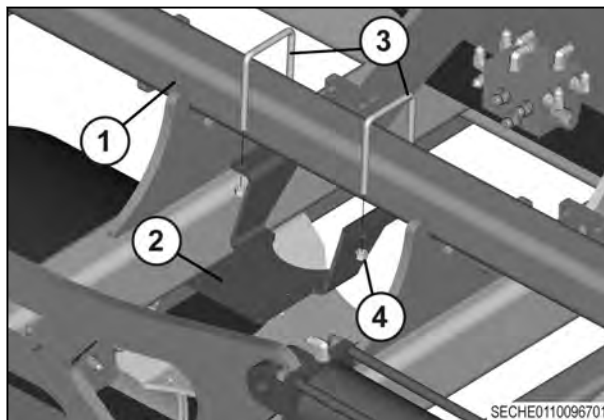

Fig. 236

34. Install the valve block (1) on the mounting bracket (2). Install the four  $3/8 \times 1$  bolts (4) and the four  $3/8$  lock washers (3).

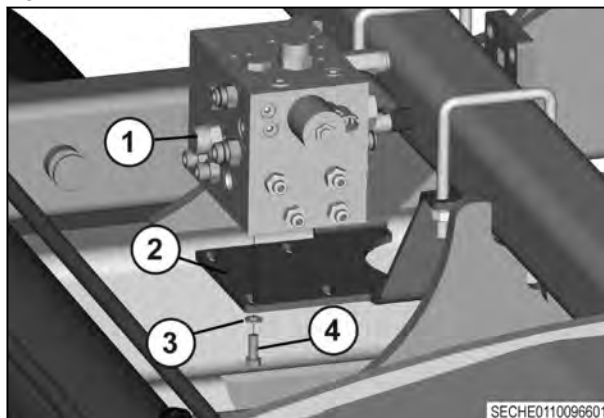

Fig. 237

35. Install the  $1/2 \times 29 \times 8$  FJX-8FJX hose (2) to the 8MB-8MJ-90 adapter (1) on the outer cylinder. Install the opposite end of the hose to the 8MB-8MJ-8MJ adapter (3) on the inner cylinder.

36. Install the  $1/2 \times 46 \times 8$  FJX-8FJX hose (4) to the 8MB-8MJ-90 adapter (6) on the outer cylinder. Install the opposite end of the hose to the 8MB-8MJ-8MJ adapter (5) on the inner cylinder.

**NOTE:** Repeat steps 35 and 36 on the opposite outer cylinder.

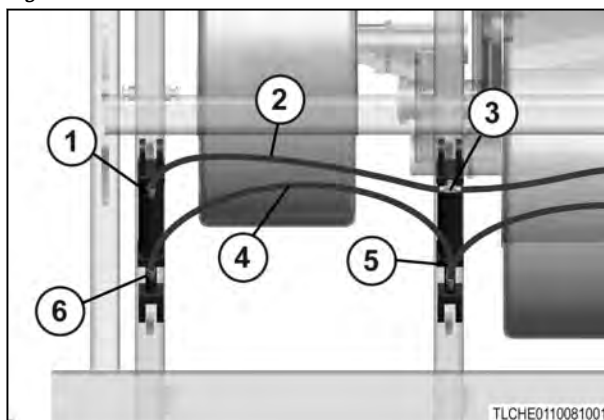

Fig. 238

37. Install the  $1/2 \times 29 \times 8$  FJX-8FJX hose (2) to the 8MJ-8MJ-8MB adapter (1). Install the opposite end of the hose to the 8MJ-8MJ-8MB adapter (3) on the adjacent inner cylinder.

Do not install upper hose between wing frame and main frame until a later installation.

38. Install the  $1/2 \times 46 \times 8$  FJX-8FJX hose (5) to the 8MJ-8FJX-90 adapter (4). Install the opposite end of the hose to the 8MB-8MJ-8MJ adapter (6) on the adjacent inner cylinder.

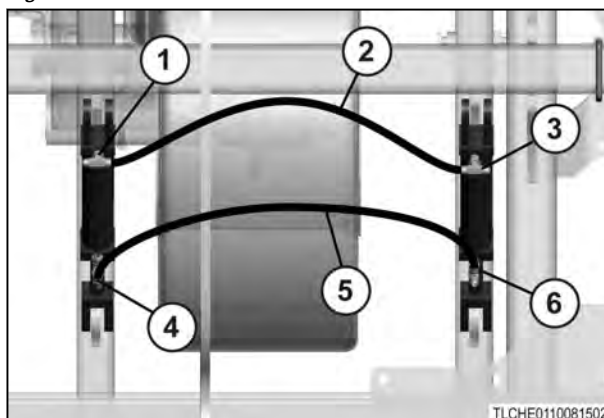

Fig. 239

39. Install the 1/2 x 23 x 8FJX-8FJX hose (1) between the ports DRCR and VR.
40. Install the 1/2 x 26 x 8FJX-8FJX hose (2) between the ports DRCE and VE.
41. Install the 1/2 x 32 x 8FJX-8FJX hose (3) between the LTCE port and the left-hand cylinder.
42. Install the 1/2 x 26 x 8FJX-8FJX hose (4) between the P1 ports.
43. Install the 1/2 x 32 x 8FJX-8FJX hose (5) between the RTCE port and the right-hand cylinder.
44. Install the 1/2 x 34 x 8FJX-8FJX hose (6) between the LTCR port and the left-hand cylinder.
45. Install the 1/2 x 34 x 8FJX-8FJX hose (7) between the RTCR port and the right-hand cylinder.
46. Install the 1/2 x 46 x 8FJX-8FJX hose (8) between the AUXR port and the down pressure cylinder.
47. Install the 1/2 x 23 x 8FJX-8FJX hose (9) between the AUXE port and the down pressure cylinder.
48. Install the 1/2 x 66 x 8FJX-8FJX hose (1) between the BV2 port and the left-hand 8MB-8MJ-90 adapter on the lock valve.
49. Install the 1/2 x 66 x 8FJX-8FJX hose (2) between the BV1 port and the right-hand 8MB-8MJ-90 adapter on the lock valve.

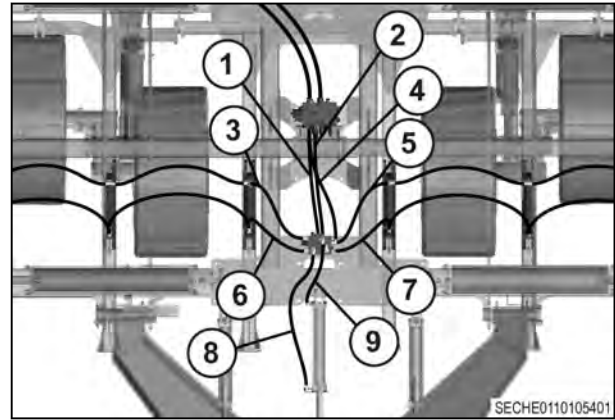

Fig. 240

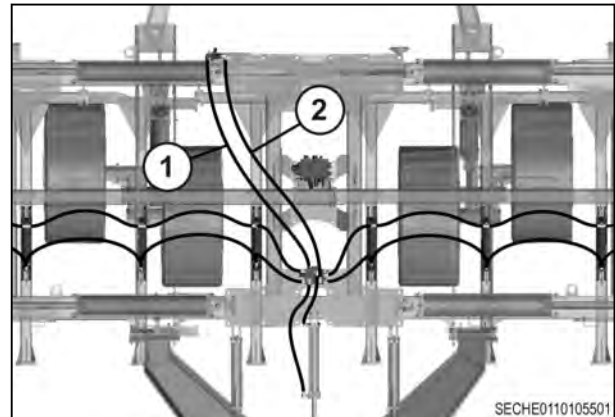
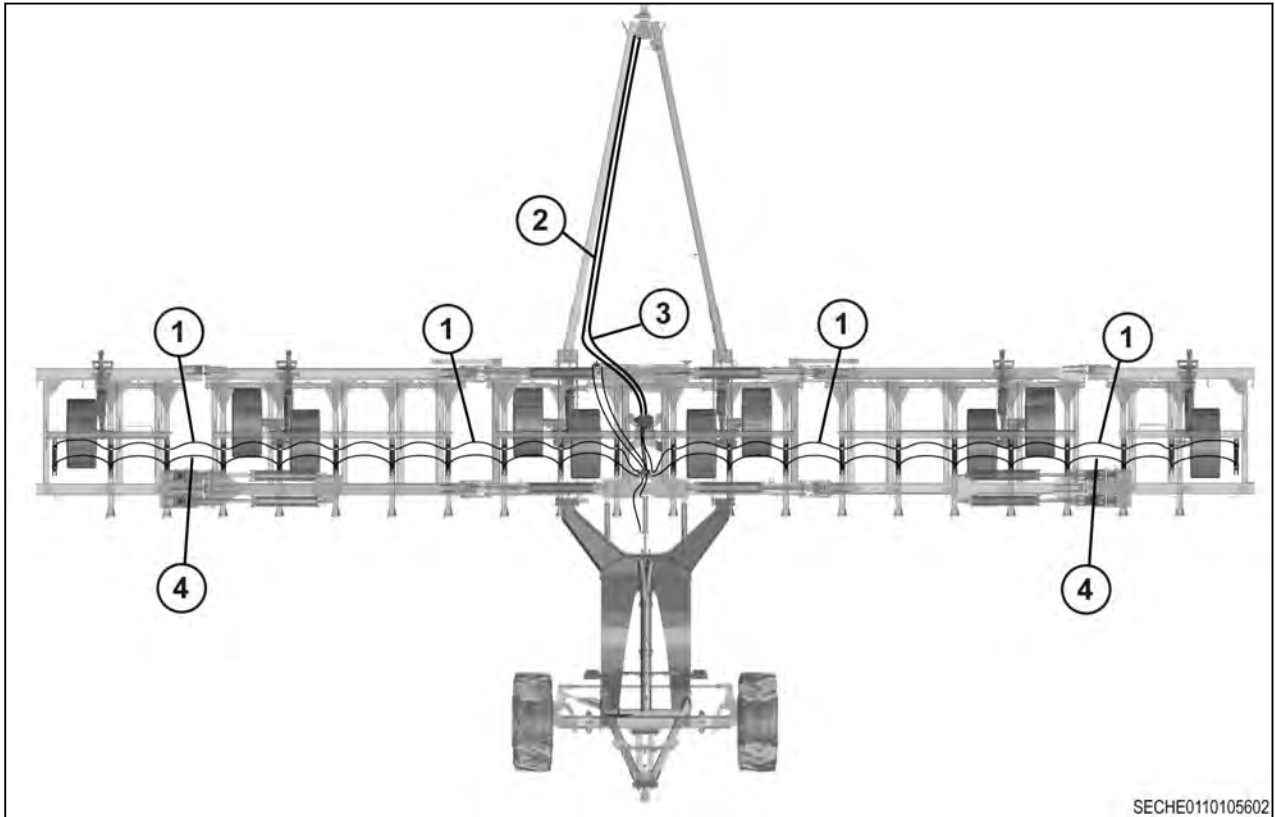

Fig. 241



SECHE0110105602

Fig. 242

50. Install the 1/2 x 32 x 8FJX-8FJX45 hoses (1) between the wing frames and main frames. Install the 45° fitting to the wing frame down pressure cylinder.
51. Install the 1/2 x 306 x 8FJX-8MB hose (3) in port SA and route the hose along the left-hand drawpole.
52. Install the 1/2 x 306 x 10FJX-8MB hose (2) in port DPTR and route the hose along the left-hand drawpole.
53. Install the 1/2 x 50 x 8FJX-8FJX hoses (4) between the wing frames.
54. Install the two #8 ORB male couplers (1) on the 1/2 x 306 x 8FJX-8FJX hose ends. Install the two toolbar decals (2) on the 1/2 x 306 x 8FJX-8FJX hoses.

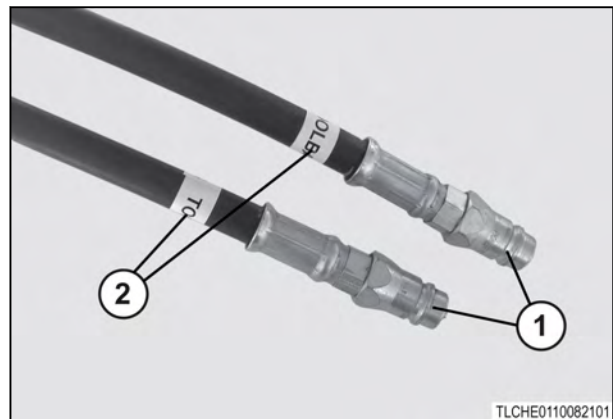

TLCHE0110082101

Fig. 243

## 7.8.2 Installing the wing lift hydraulics on the hydraulic lift assist

1. Install the front cylinder mount (2) to the main frame (4). Install the eight  $3/4 \times 2-1/2$  bolts (1), the  $3/4$  washers (3), and the  $3/4$  nuts (5).

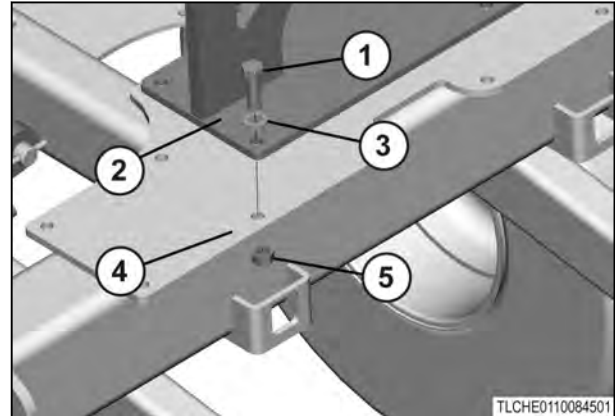

Fig. 244

2. Install the rear cylinder mount (3) to the main frame (4). Install the eight  $3/4 \times 2-1/2$  bolts (1), the sixteen  $3/4$  washers (2) (5), and the eight  $3/4$  nuts (6).

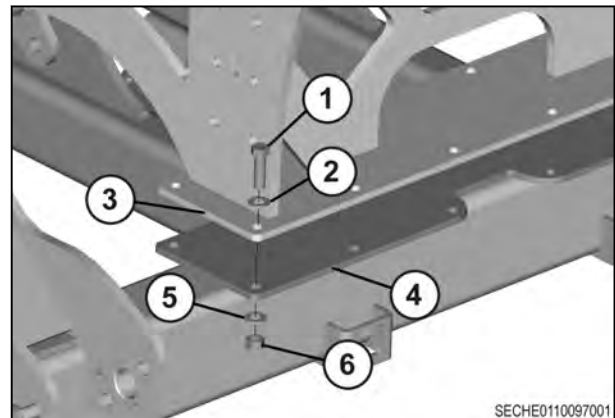

Fig. 245

3. Install the rear cylinder mount (2) to the main frame (1). Install the six  $5/8 \times 5-1/2 \times 4 \times 5-1/2$  U-bolts (5), twelve  $5/8$  flat washers (4) and the twelve  $5/8$  lock nuts (3).

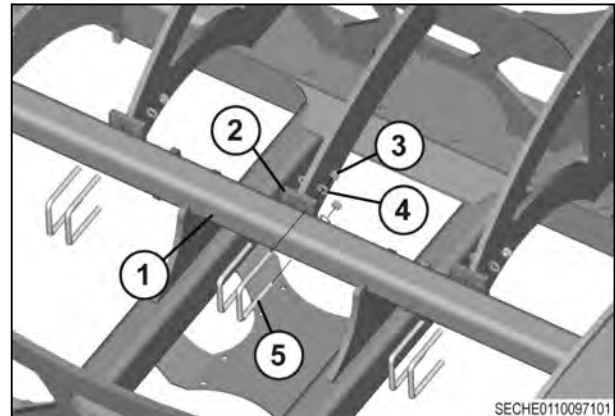

Fig. 246

4. Install the cylinder mount bracket (2) on the rear cylinder mount (1). Install the six 5/8 x 2-1/2 bolts (4), 5/8 flat washers (3), and the 5/8 flange lock nut (5).
5. Repeat the previous step for the opposite cylinder mount bracket.

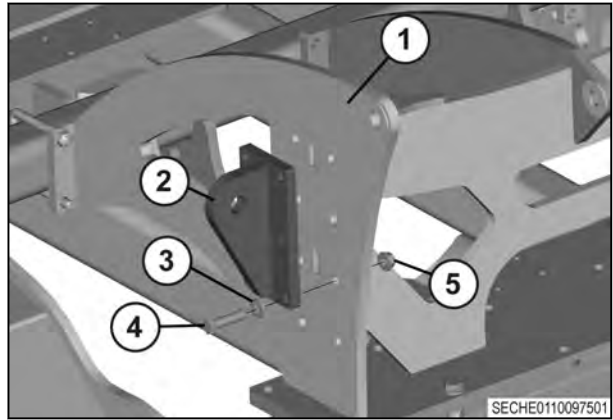

Fig. 247

6. Install the wing lift cylinder (4) to the bracket (3). Install the 1-1/4 x 6-5/8 pin (2) and the two 3/8 roll pins (1).
7. Repeat the previous step for the opposite wing lift cylinder.

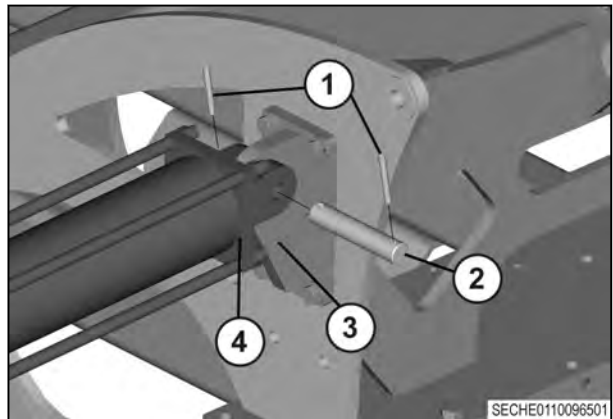

Fig. 248

8. Align the cylinder base (4) with the front cylinder mount (2). Insert the 1-1/4 x 6-3/8 pin (3) and install the two 3/8 x 3 roll pins (1).
9. Repeat the previous step for the opposite wing lift cylinder.

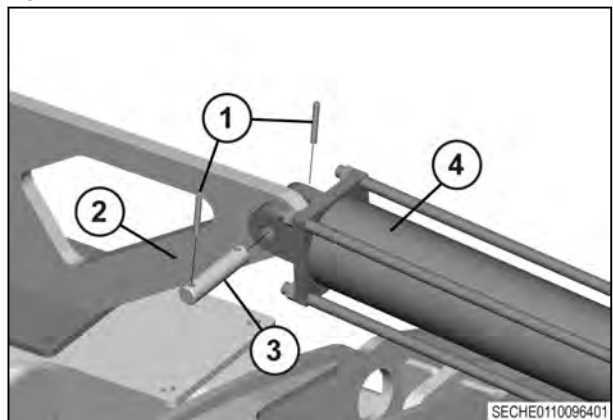

Fig. 249

10. Align the cylinder piston rod (2) with the wing frame mount (5). Install the four 1-1/4 washers (3) and the 1-1/4 x 3-3/8 pin (4). Install the two 3/8 roll pins (1).
11. Repeat the previous step for all of the inner wing lift cylinders.

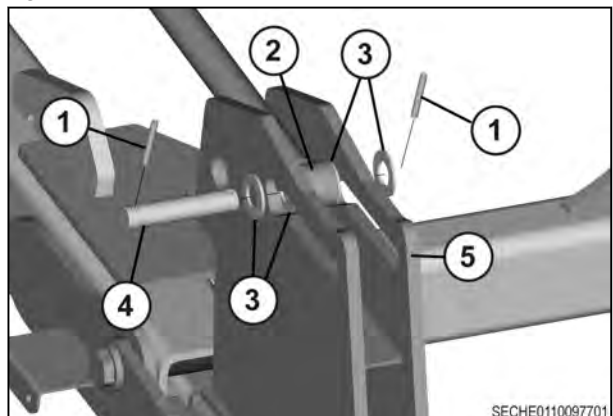

Fig. 250



12. Align the two cylinder bases (4) with the cylinder mount (2). Insert the two 1-1/4 x 6-3/8 pins (3) and install the four 3/8 x 3 roll pins (1).
13. Repeat the previous step for the opposite outer wing lift cylinders.

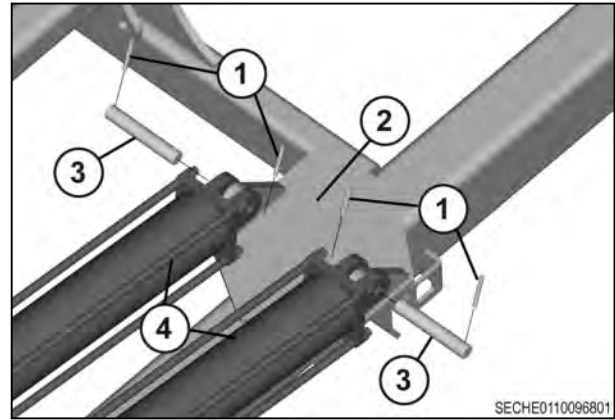

Fig. 251

14. Align the two cylinder piston rods (4) with the two extension wing linkage assemblies (3). Install the two 1-1/4 x 3-3/8 pins (2). Install the four 3/8 roll pins (1).
15. Repeat the previous step for the opposite outer wing lift cylinders.

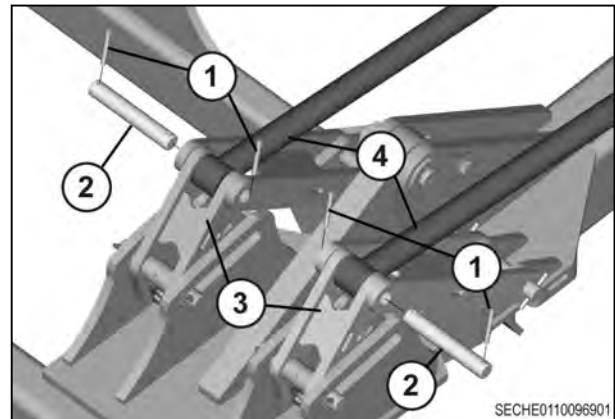

Fig. 252

16. Install the two 8MB-8MJ-90 fittings (1) (4) and the 8FJ-8MJ .090 restrictor fitting (2) in the inner wing lift cylinders (3).
17. Repeat the previous step for the remaining inner wing lift cylinders.

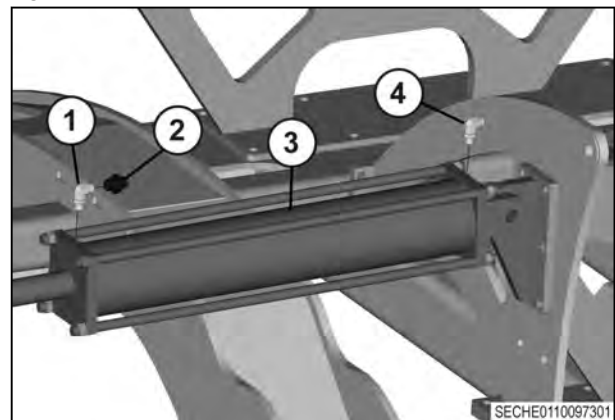

Fig. 253

18. Install the three 8MB-8MJ-90 fittings (5) (3), the two 8FJ-8MJ .090 restrictor fittings (4), the 8MJ-8FJX-8MJ fitting (1), and the 9MJ-8MJ-8MB fitting (2) on the outer wing lift cylinders.
19. Repeat the previous step for the opposite outer wing lift cylinders.

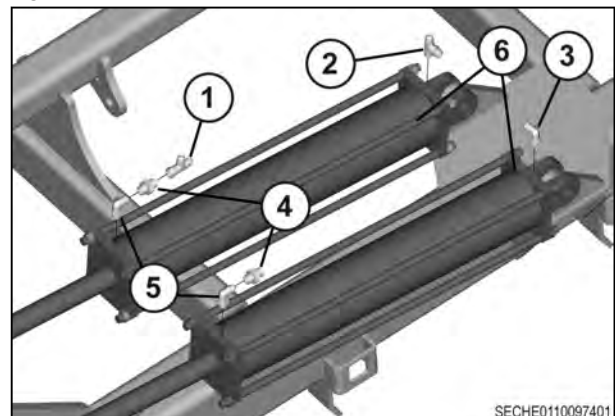

Fig. 254

- 20. Install the two 8MB-8MJ fittings (2) (3) in the WTR and WTE ports on the main block valve (1).
- 21. Install the four 6MB-8MJ fittings (4) (5) (6) (7) in the ILWE, OLWE, ILWR, and OLWR ports.

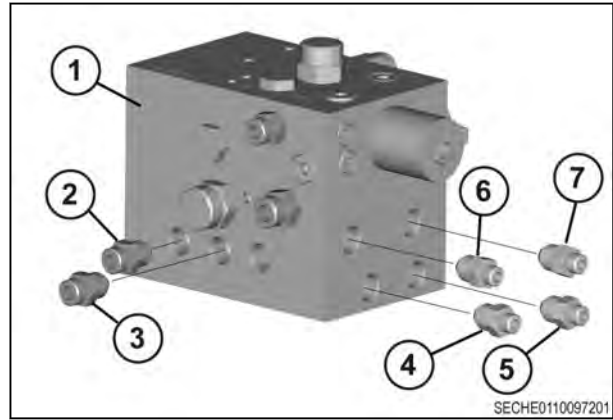

Fig. 255

- 22. Install the four 6MB-8MJ fittings (2) (3) (4) (5) in the IRWE, ORWE, IRWR, and ORWR ports on the main block valve.

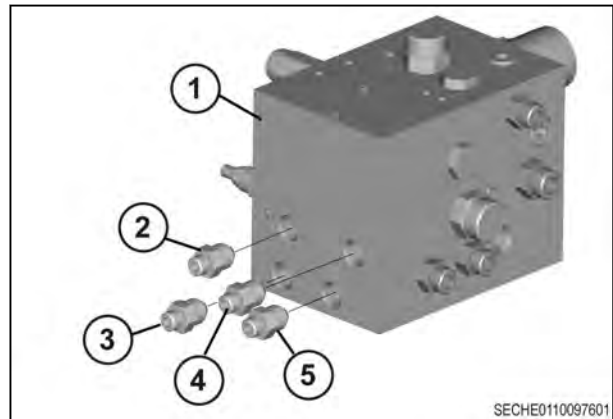

Fig. 256

- 23. Install the main block valve mounting bracket (2) on the main frame (1). Install the two 1/2 x 5-1/2 x 4 x 5-1/2 U-bolts (3) and the four 1/2 lock nuts (4).

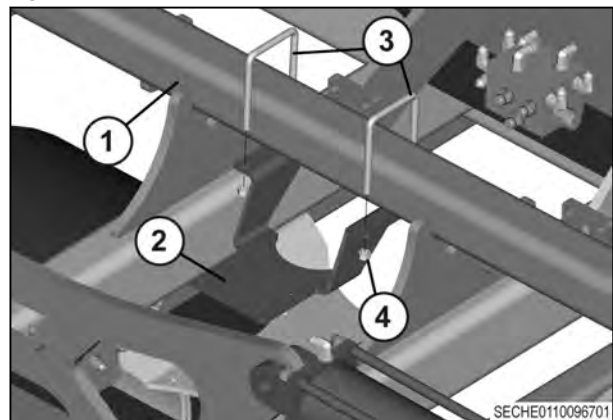

Fig. 257

- 24. Install the main block valve (1) on the bracket (2). Install the four 3/8 x 1 bolts (4) and the 3/8 lock washers (3).

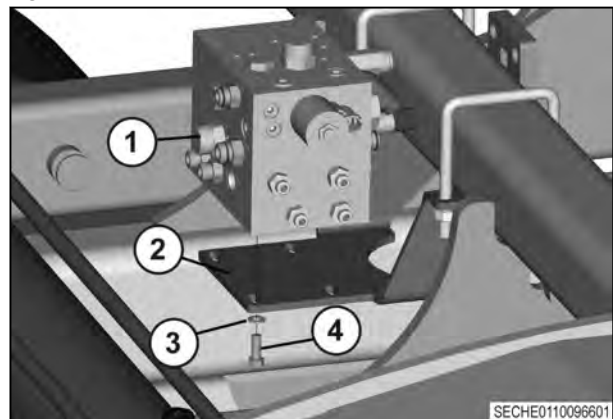

Fig. 258

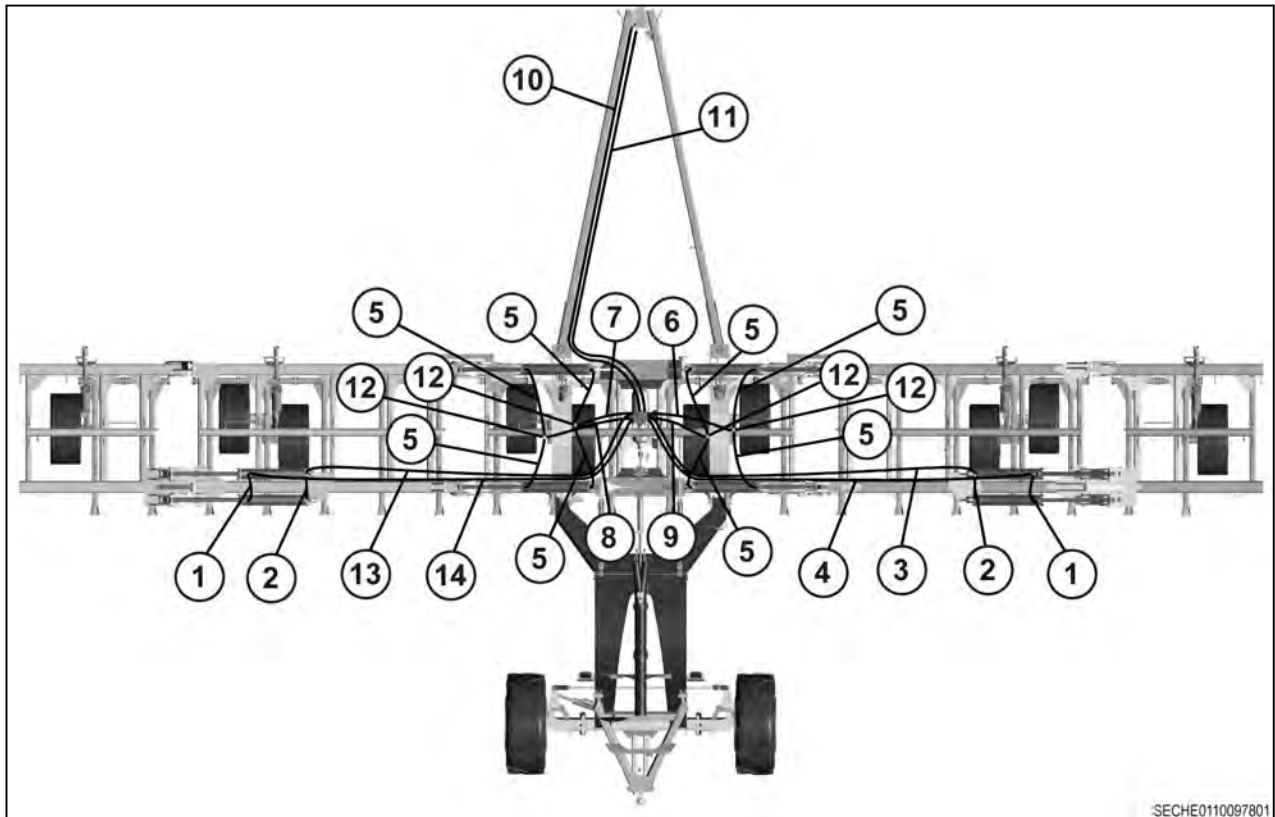

Fig. 259

**NOTE:** 40ft HLA frame does not include outer wing lift cylinders or hoses.

25. Install the two 3/8 x 20 x 8FJX-8FJX90 hoses (1) between the outer cylinders.
26. Install the two 3/8 x 20 x 8FJX-8FJX hoses (2) between the outer cylinders.
27. Install the 1/2 x 198 x 8FJX-8FJX hose (3) to the outer cylinder and the ORWR port.
 

**NOTE:** Replace the 1/2 x 198 x 8FJX-8FJX hose (3) with the 258 inch hose on the 60ft frame.
28. Install the 1/2 x 228 x 8FJX-8FJX hose (4) to the outer cylinder and the ORWE port.
29. Install the 1/2 x 198 x 8FJX-8FJX hose (13) to the outer cylinder and the OLWR port.
 

**NOTE:** Replace the 1/2 x 198 x 8FJX-8FJX hose (13) with the 258 inch hose on the 60ft frame.
30. Install the 1/2 x 228 x 8FJX-8FJX hose (14) to the outer cylinder and the OLWE port.
31. Install the eight 3/8 x 34 x 8FJX-8FJX hoses (5) between the inner cylinders and the four 8MJ-8MJ-90 fittings (12).
32. Install the 3/8 x 34 x 8FJX-8FJX hose (6) between the 8MJ-8MJ-90 fitting (12) and the IRWR port.
33. Install the 3/8 x 34 x 8FJX-8FJX hose (7) between the 8MJ-8MJ-90 fitting (12) and the ILWR port.
34. Install the 3/8 x 34 x 8FJX-8FJX hose (8) between the 8MJ-8MJ-90 fitting (12) and the ILWE port.
35. Install the 3/8 x 34 x 8FJX-8FJX hose (9) between the 8MJ-8MJ-90 fitting (12) and the IRWE port.
36. Install the 1/2 x 306 x 8FJX-8MB hose (10) in the WTR port and route along the left-hand drawpole.
37. Install the 1/2 x 306 x 8FJX-8MB hose (11) in the WTE port and route along the left-hand drawpole.

38. Install the #8 ORB male couplers (1) and decals (2) on the two 1/2 x 290 x 8FJX-8MB hoses.

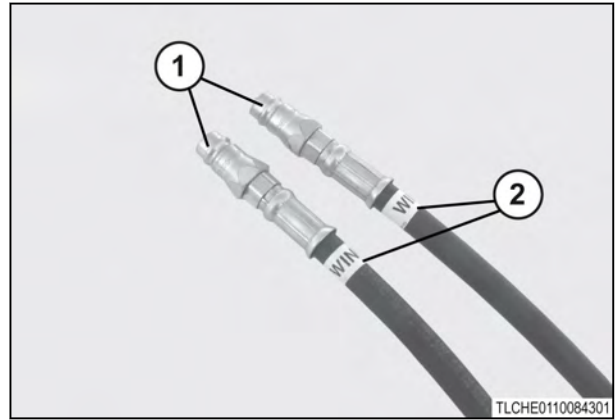

Fig. 260

### 7.8.3 Installing the hydraulic lift assist frame to the main frame

1. Align the frame (3) with the main frame (2) and insert the 12-1/2 x 2 flag pin (1).

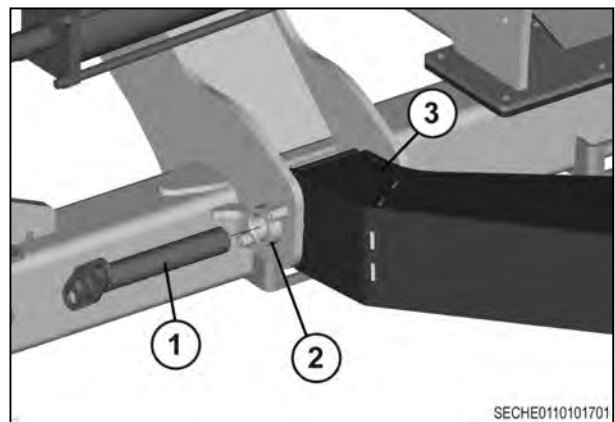

Fig. 261

2. Install the flag pin (3) to the main frame with the two 1/2 x 2-1/2 bolts (1), the 1/2 lock washers (2), and the 1/2 flat washers (4).

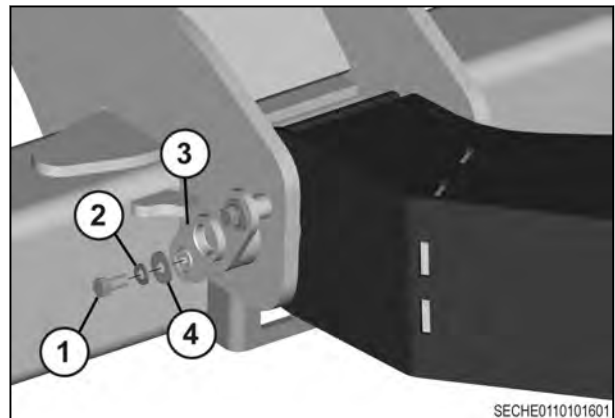

Fig. 262

3. Install the grease fitting (1) in the flag pin.
4. Install the opposite side of the frame.

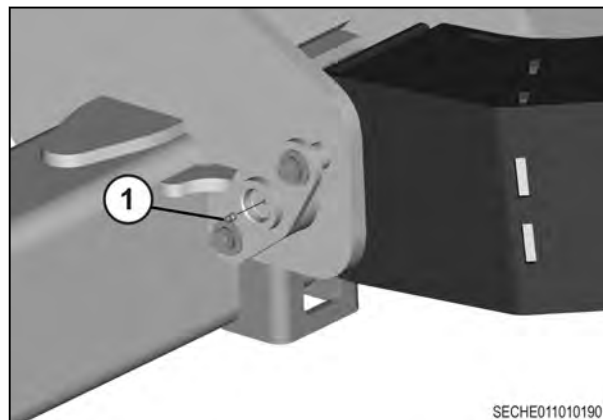

Fig. 263

5. Support the end of the frame (1) with floor jacks (2).

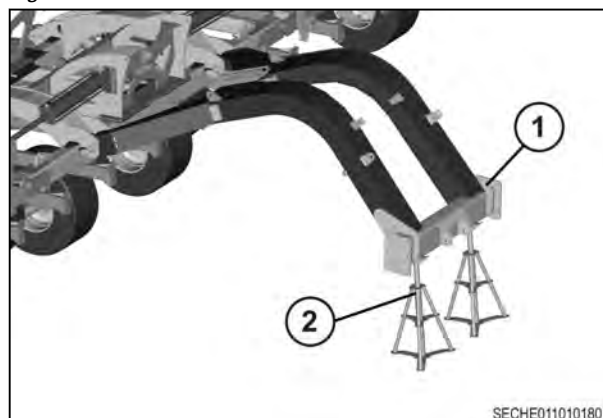

Fig. 264

#### 7.8.4 Assembling the hydraulic lift assist rear axle

1. Align the outer axle (1) with the frame. Install the eight  $3/4 \times 2-3/4$  bolts (4),  $3/4$  lock washers (3), and the  $3/4$  nuts (2).

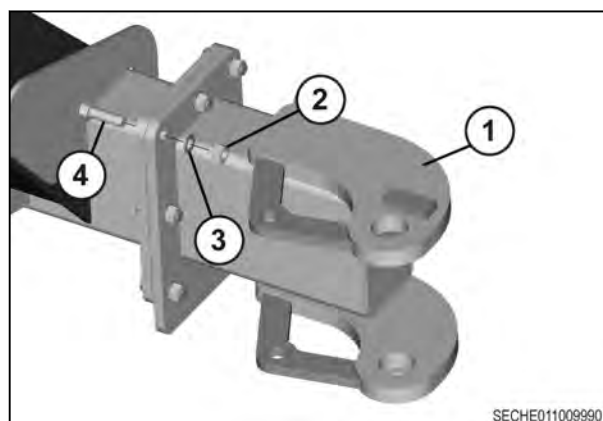

Fig. 265

2. Insert the two 2-1/2 x 2-3/4 bushings (2) (4) and the thrust bushing (1) in the trunnion (3).

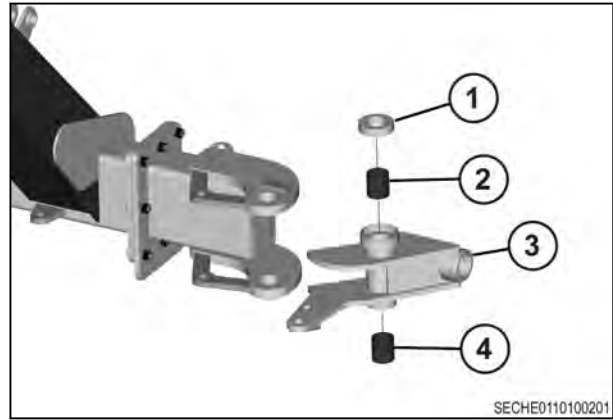

Fig. 266

3. Align the trunnion assembly (2) with the outer axle (1).

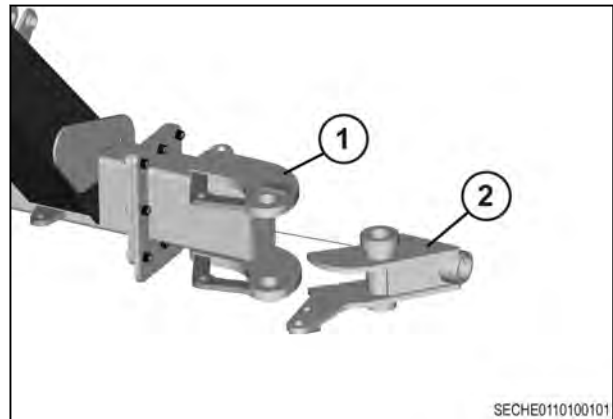

Fig. 267

4. Insert the king pin (1) through the outer axle (2) and the trunnion assembly. Install the king pin with the 1-1/2 jam nut (3).

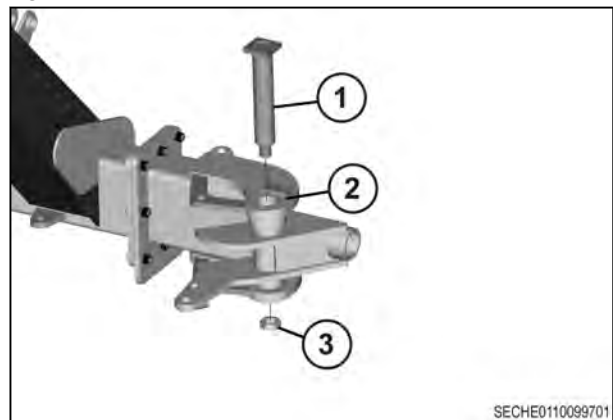

Fig. 268

5. Install the upper grease fitting (1) in the king pin.

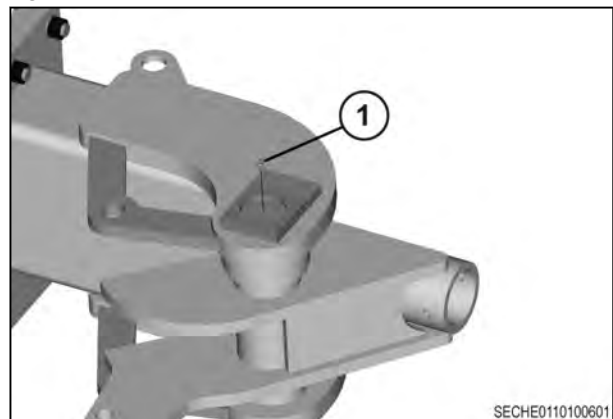

Fig. 269

6. Install the bottom grease fitting (1) in the king pin.

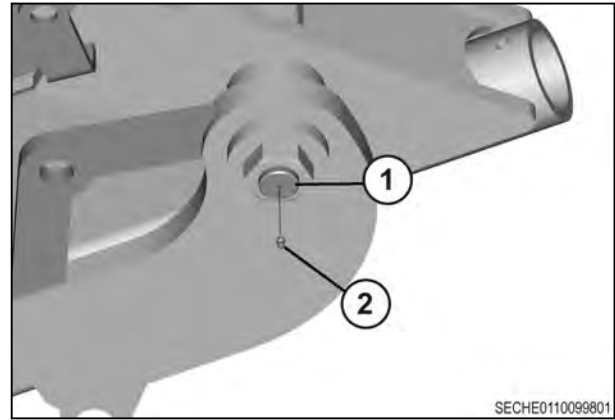

Fig. 270

7. Insert the pivot stop pin (1) in the outer axle (2).

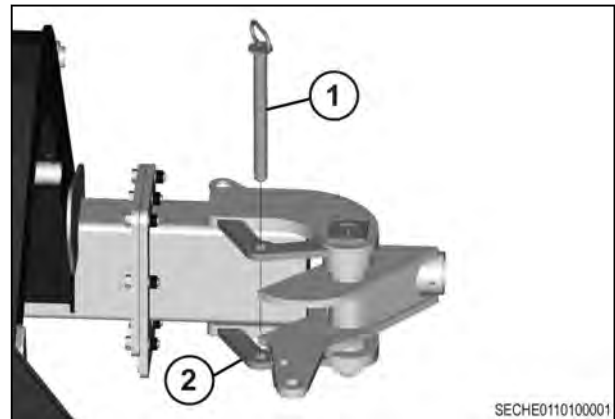

Fig. 271

8. Install the hub and spindle (3) in the trunnion tube. Install the 1/2 x 5-1/2 bolt (2) and the 1/2 lock nut (1).

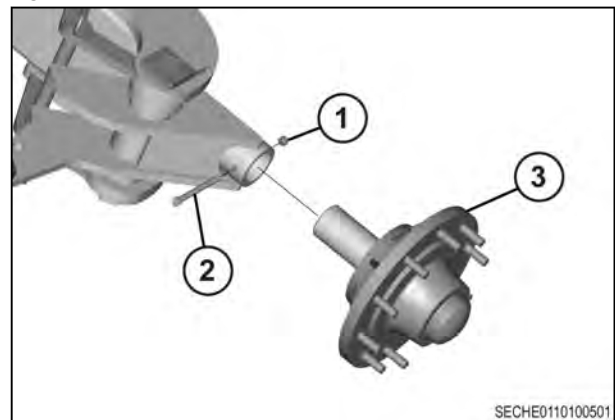

Fig. 272

9. Assemble the tie rod by installing the 1-1/4 jam nut (2) and the tie rod clevis (3) on the 2-1/8 tie rod (1).

**NOTE:** Leave jam nut loose until tow is set.

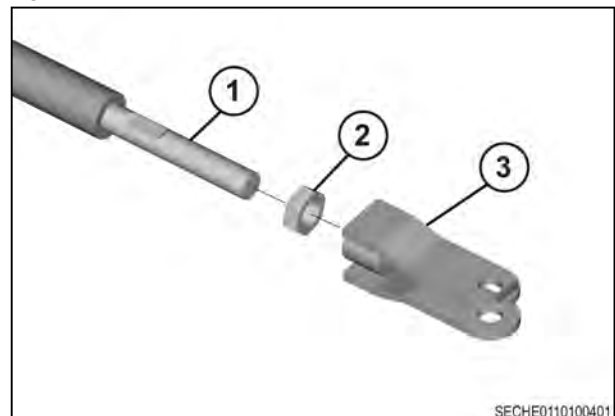

Fig. 273

10. Install the grease fitting (1) in the hex bolt (2). Place the tire rod assembly with the stop (3) upwards on the trunnion. Install the assembly with the 1 inch hex bolt (2), 1 inch hex nut (4), and 1/4 cotter pin (5).

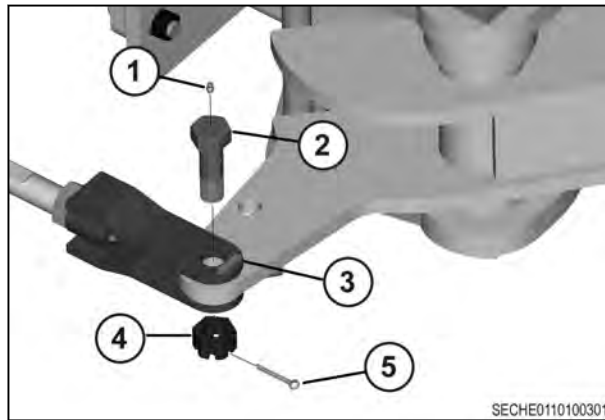

Fig. 274

11. Install the wheel over the lug bolts and install the lug nuts (1).
12. Install opposite rear wheel and caster assembly.
13. Set the tow with the tie rod by tightening the jam nuts when all sides have been assembled.



Fig. 275

### 7.8.5 Installing the hydraulic lift assist

1. Install the 5 gallon accumulator tank (4) on the main frame bracket (3). Install the two 1/2 x 9-1/2 x 10-1/2 U-bolts (2). Place the accumulator tank (4) with the valve end (1) to the rear of the machine.

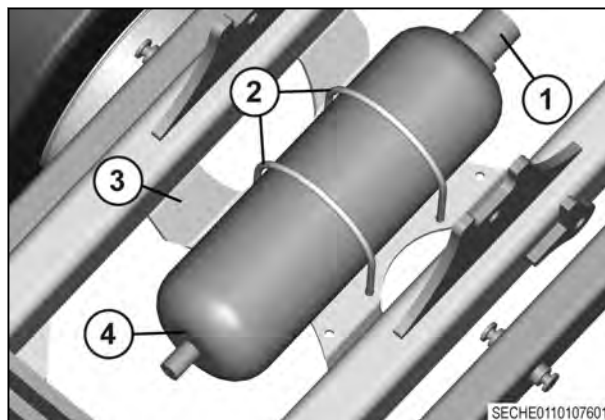

Fig. 276



2. Install the U-bolts (1) with the four 1/2 washers (2) and 1/2 lock nuts (3).

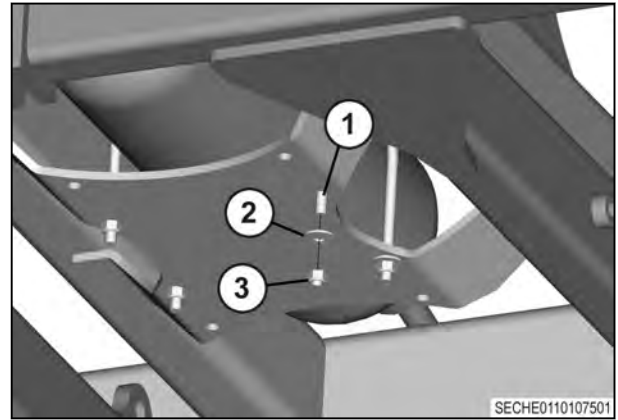

Fig. 277

3. Install the pressure gauge bracket (2) to the right-hand side of the main frame (3). Install the two 3/4 x 1-1/2 bolts (1) and the two 3/4 lock nuts (4).

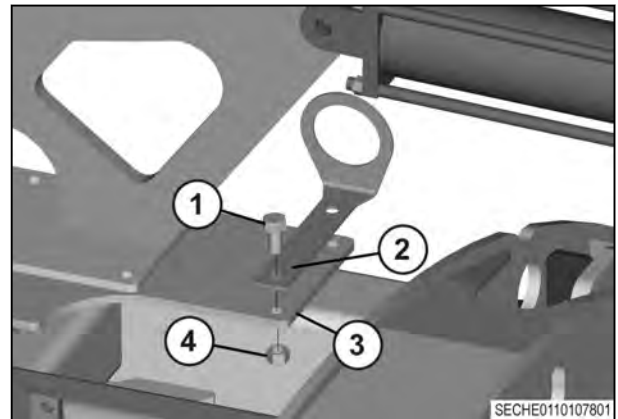

Fig. 278

4. Install the pressure gauge (3) into the bracket (2) and attach the 8MJ-8FP adapter (1).

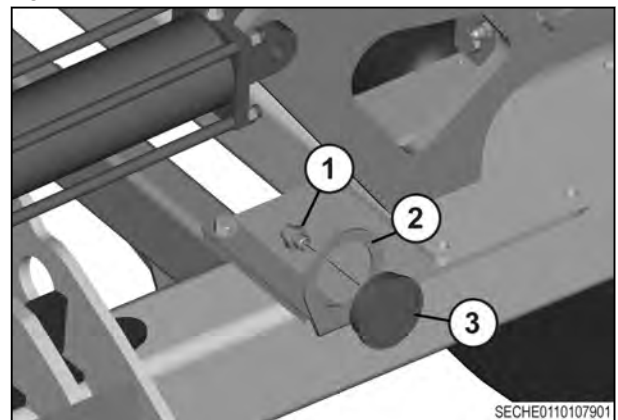

Fig. 279

5. Install the 8MB-8MJ-90 adapter (7) in the 3500 psi relief valve (5). Install the 8MB-8FJX adapter (3) in the relief valve (5). Assemble the two 8MJ-8FJX-8MJ adapters (1) (4), the 8MJ-8MJ-8FJX adapter (2), and the 16MB-8MJ-90 adapter (6).

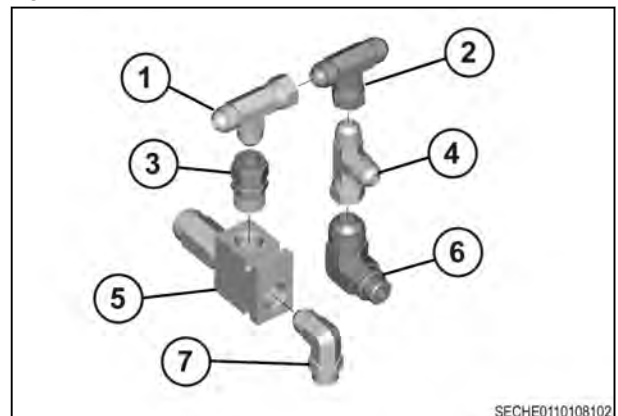

Fig. 280

6. Install the relief valve and hydraulic fittings (1) on the accumulator tank.

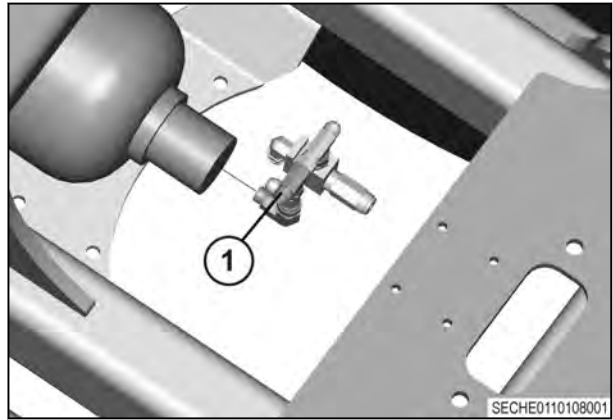

Fig. 281

7. Install the 8MB-8MJ-90 adapter (1) to the single action hydraulic cylinder (2).
8. Repeat the previous step for the opposite hydraulic cylinder.

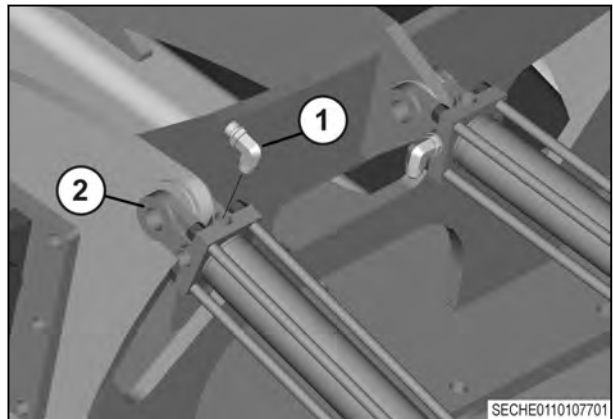

Fig. 282

9. Align the lift cylinder (4) with the rear cylinder mount (2). Install the 1-1/2 x 5-1/4 pin (3), the two 1-1/2 washers (5), and the two 3/8 x 3 roll pins (1).

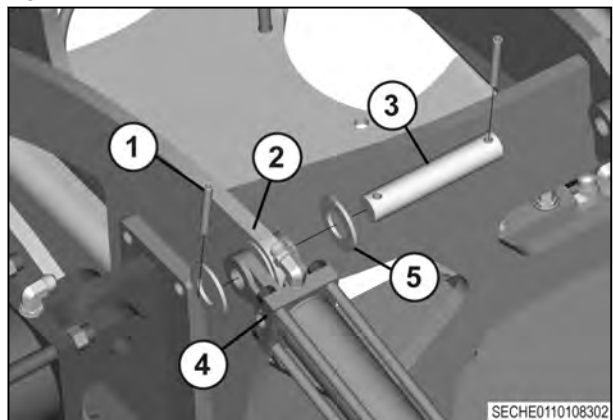

Fig. 283

10. Align the lift cylinder (2) with the HLA cylinder mount. Install the 1-1/2 x 5-1/4 pin (3), the two 1-1/2 washers (4), and the two 3/8 x 3 roll pins (1).

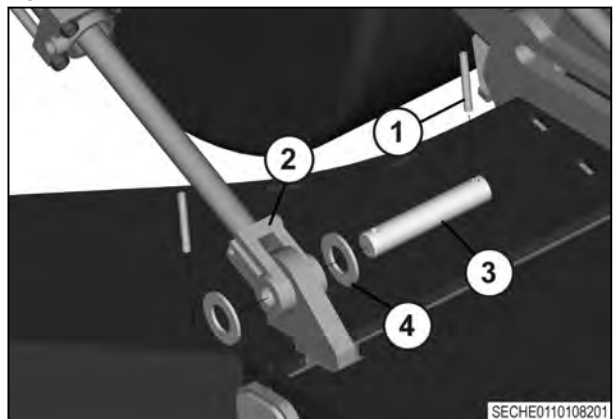
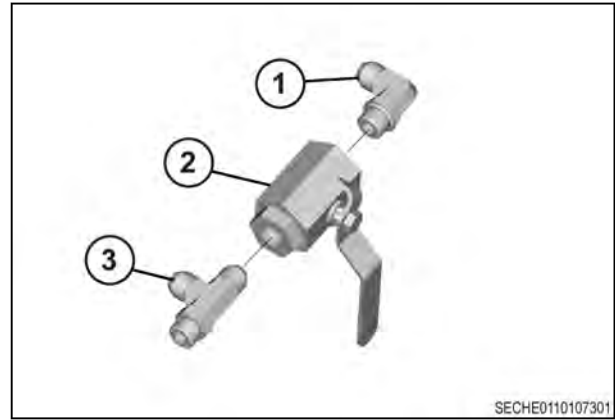

Fig. 284

- 11.** Install the 8MB-8MJ-90 adapter (1) and the 8MB-8MJ-8MJ adapter (3) in the ball valve (2).



SECHE0110107301

Fig. 285

- 12.** Install the ball valve assembly (1) in the right-hand side of the lock valve bracket.

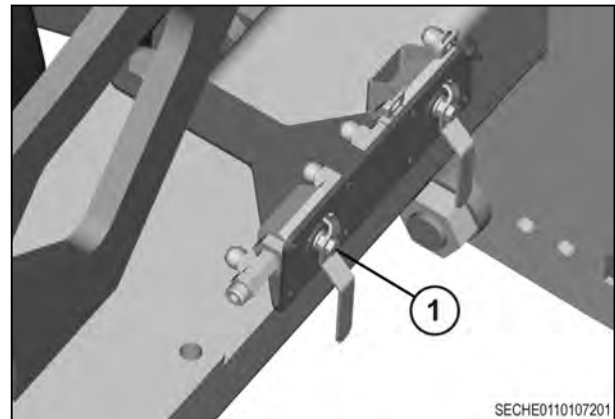

SECHE0110107201

Fig. 286

- 13.** Install the ball valve clamp (2) with the four 1/4 x 1-1/4 bolts (1) and the four 1/4 lock nuts (3).

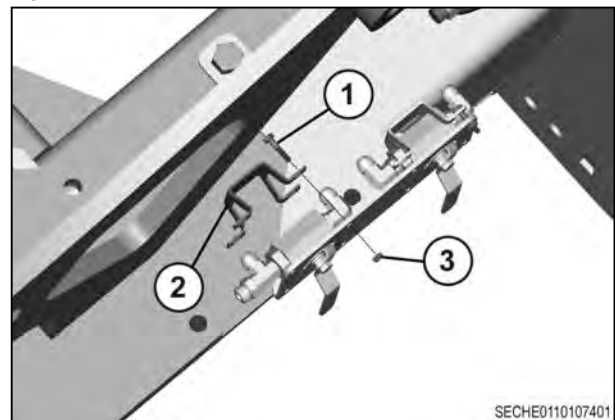

SECHE0110107401

Fig. 287

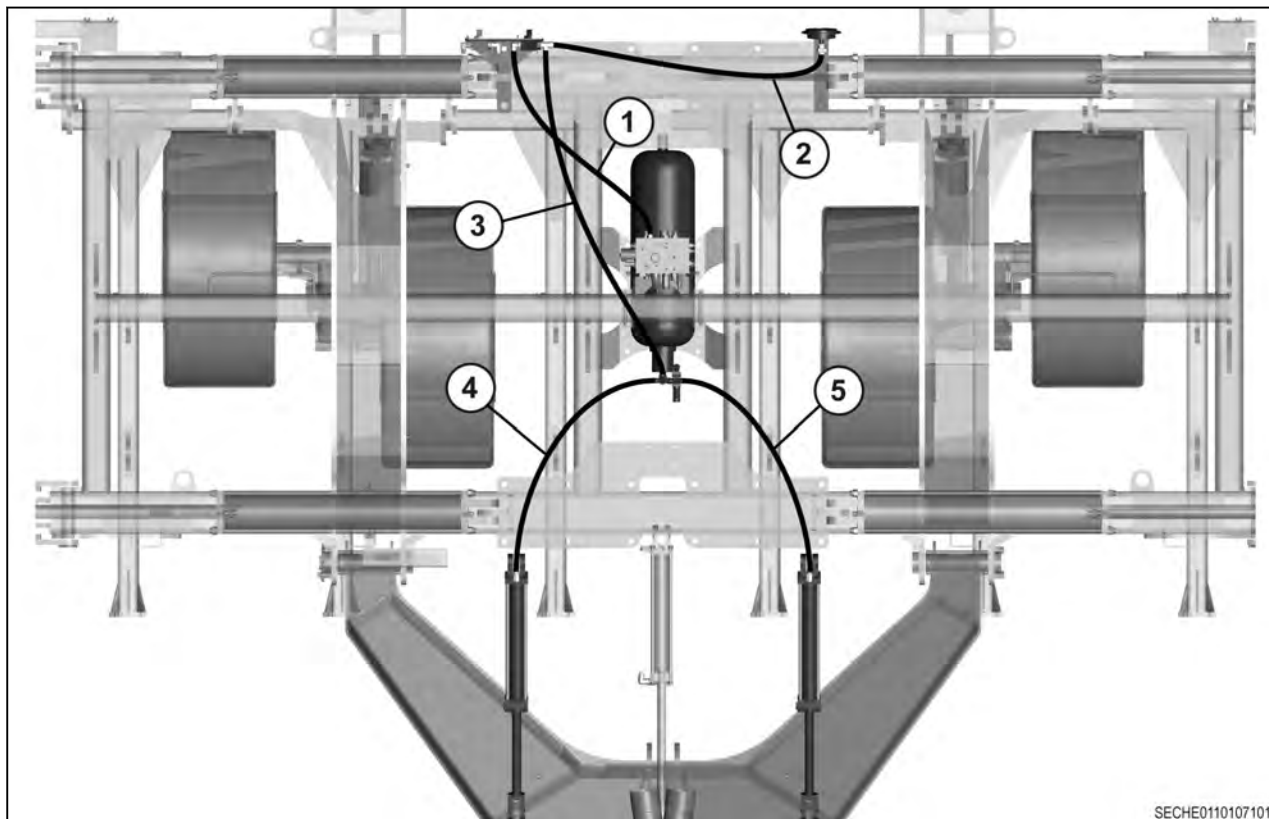

Fig. 288

14. Install the  $3/8 \times 38 \times 8\text{FJX-8FJX-90}$  (2) hose between the lock valve assembly and the pressure gauge.
15. Install the  $1/2 \times 38 \times 8\text{FJX-8FJX}$  (1) hose to the lock valve and in the port SA on the main valve block.
16. Install the  $1/2 \times 55 \times 8\text{FJX-8FJX}$  hose (3) to the lock valve and the 8MJ-8FJX-8MJ adapter on the relief valve assembly.
17. Install the two  $1/2 \times 48 \times 8\text{FJX-8FJX}$  hoses (4) (5) to the relief valve assembly and the lift cylinders.

### 7.8.6 Installing the bulkhead on the hydraulic lift assist

1. Install the bulkhead (4) to the upper frame. Install the two  $3/8 \times 5-1/2 \times 4 \times 5-1/2$  U-bolts (1), the four  $3/8$  washers (3), and the  $3/8$  lock nuts (2).

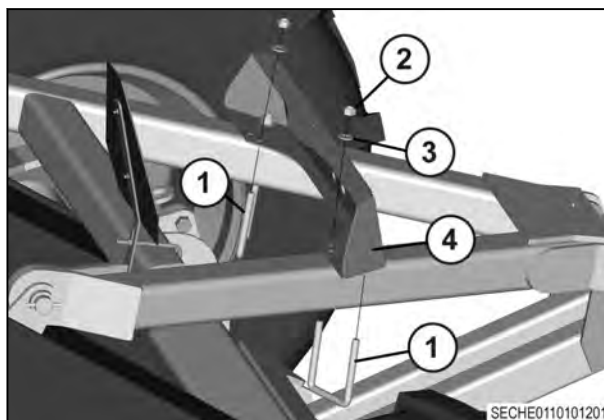

Fig. 289

2. Install the IBBC Connector (2) in the bulkhead (3) with the four 1/4 x 1 screws (1) and the 1/4 lock nuts (4)

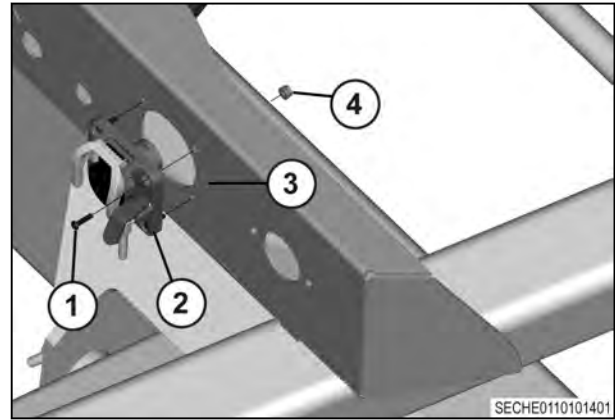

Fig. 290

3. Install the two 12MB-12MJ fittings (4) and the 10MB-10MJ fitting (3) in the front of the bulkhead (5). Connect the two 12-12 ORB female couplings (1) and the 10-10 ORB female coupling (2) to the rear side of the bulkhead (5).
4. Install the 4-3/8 clamps to the frame with the 3/8 x 1-1/4 bolts and the 3/8 lock washer.

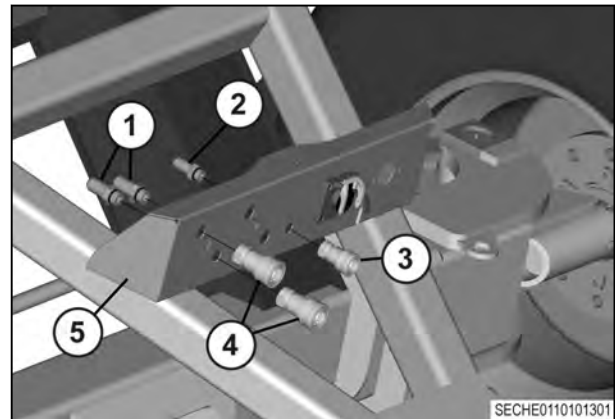

Fig. 291

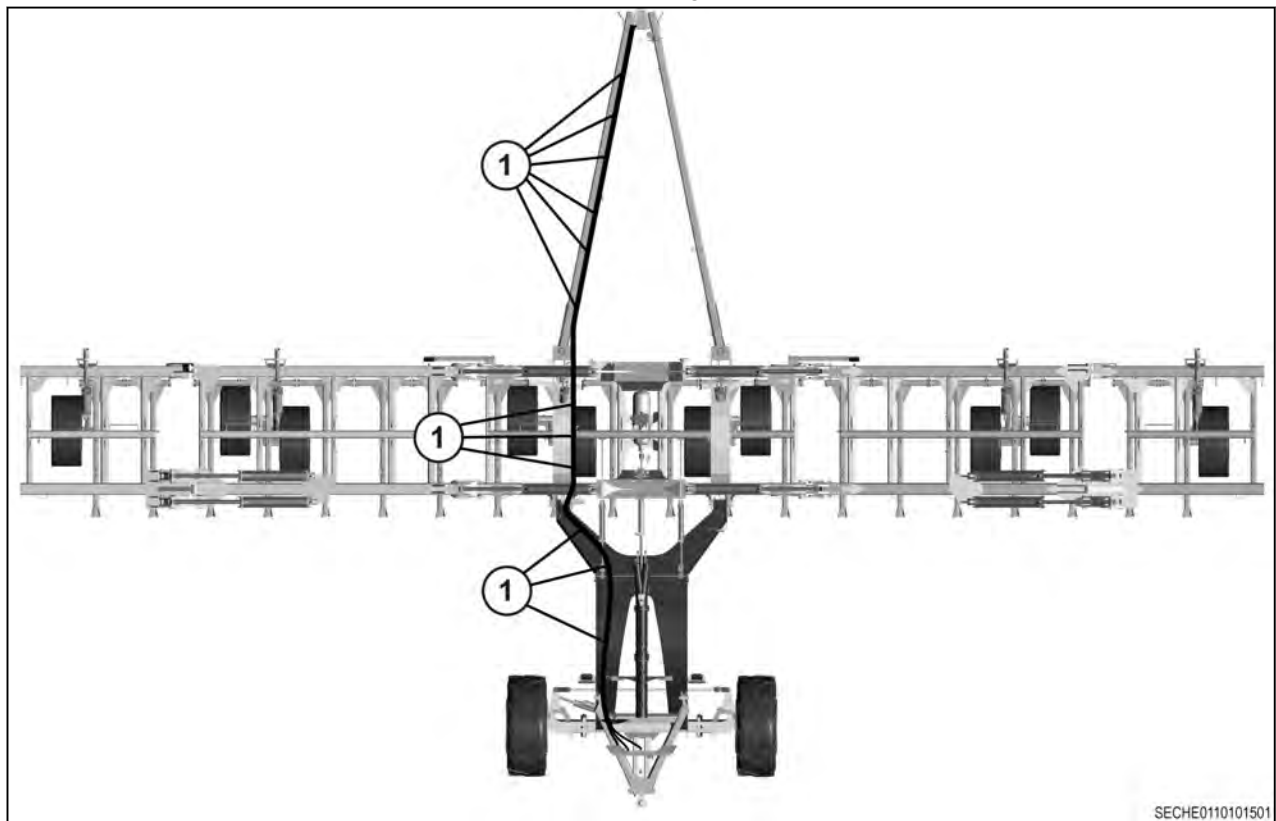

Fig. 292

5. Route hoses from bulkhead up left-hand of floating rear hitch and install the clamps (1). Install the hoses to the inside of the left-hand main frame and install clamps (1). Route hoses from main frame up left-hand drawpole and install clamps (1).

6. Place the case drain, return, and pressure decals on the front end of the hoses.
7. Install the couplers on the front end of the hoses.

### 7.8.7 Installing the rear hitch on the hydraulic lift assist

1. Install the lower hitch (1) with the 1-1/2 x 14-1/8 pin (2) and the two 3/8 x 3 roll pins (3).

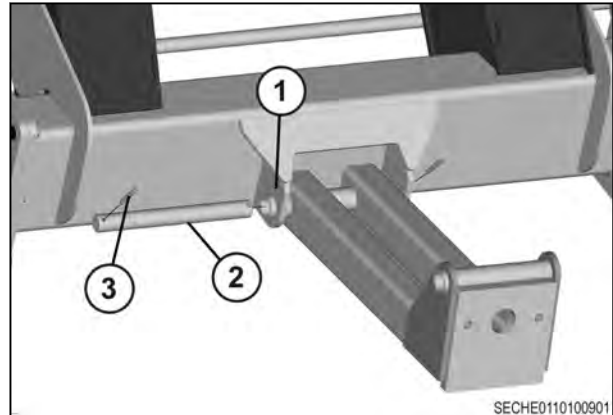

Fig. 293

2. Install the upper hitch (3) to the frame. Install the two 1-1/2 x 5-1/4 pins (2) and the four 3/8 x 3 roll pins (1).

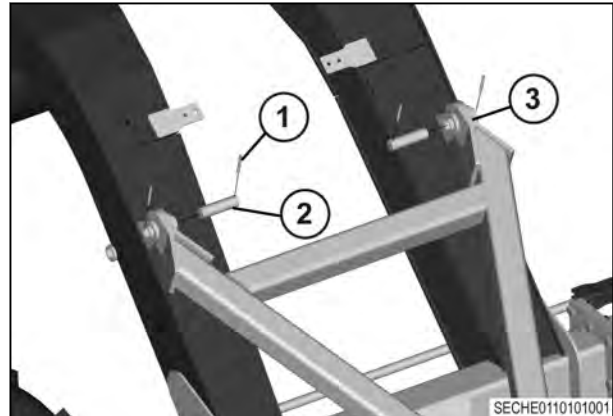

Fig. 294

3. Install the upper hitch to the lower hitch (2) with the 1-1/2 x 14-1/8 pin (3) and the two 3/8 x 3 roll pins (1).

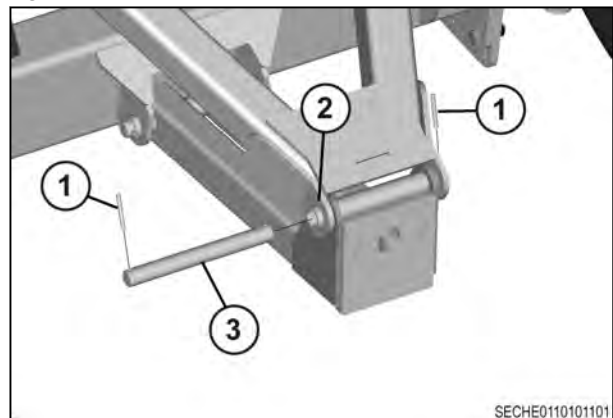

Fig. 295

4. Install the ball hitch (5) to the lower hitch (4) with the back plate (2) and hitch nut (1). Install the two  $3/4 \times 2-1/2$  bolts (6) and the two  $3/4$  nuts (3).

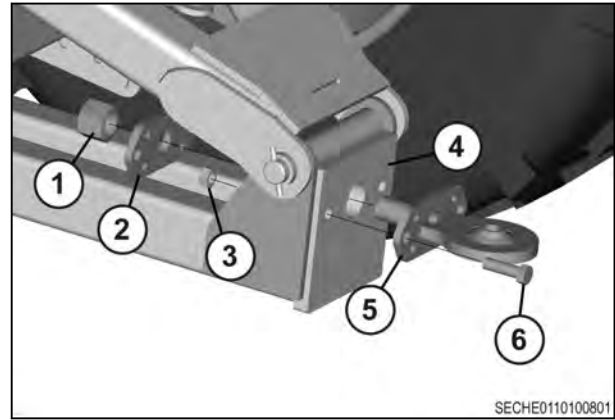

Fig. 296

### 7.8.8 Installing the hydraulic caster lock

1. Install the caster lock cylinder to the rear frame. Install the pin (2) and the two C-clips (1).

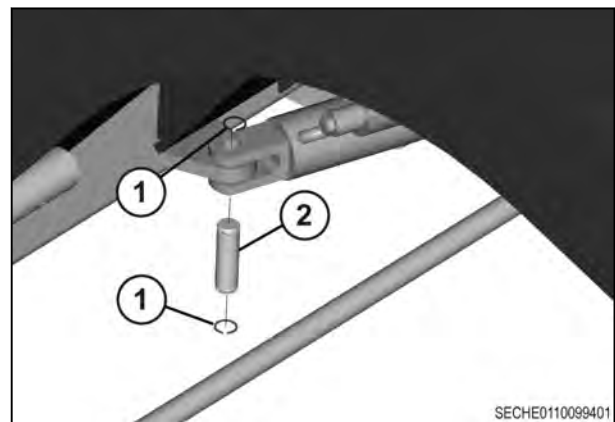

Fig. 297

2. Install the hydraulic caster lock cylinder to the trunnion. Install the pin (2) and the two C-clips (1).

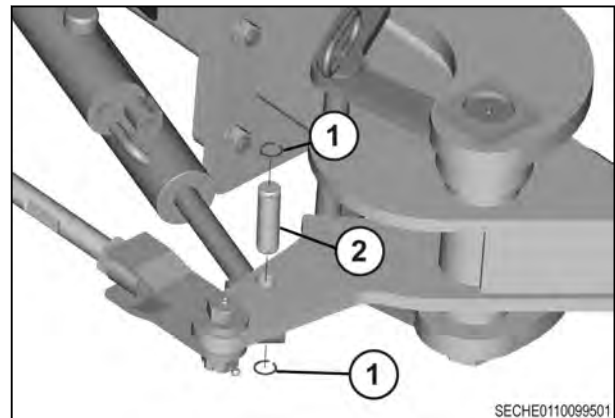

Fig. 298

3. Connect the main harness to the solenoid (1).

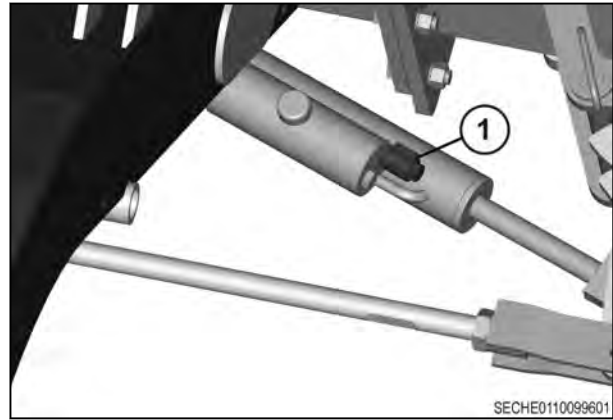

Fig. 299

### 7.8.9 Installing the rolling mount flow divider on the hydraulic lift assist

1. Remove the bottom assembly (1) by removing the four flange nuts (2).

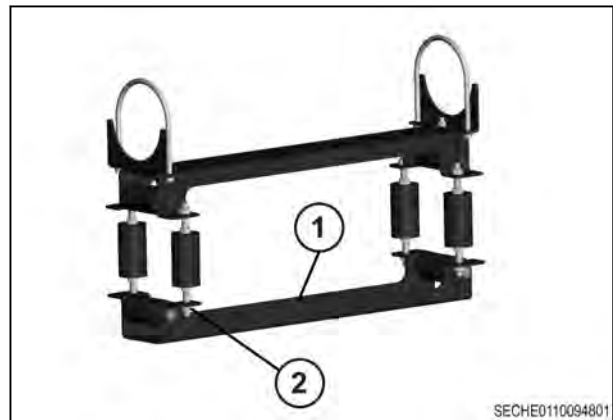

Fig. 300

2. Install the flow divider mount (1) to the HLA frame. Install the four 1/2 x 1-1/4 bolts (2), the 1/2 washers (3), and the 1/2 lock nuts (4).

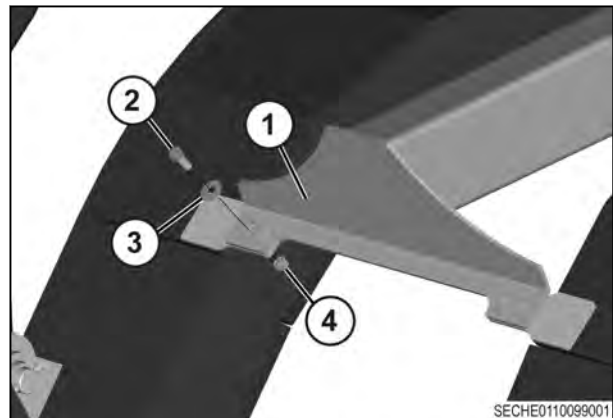

Fig. 301



3. Install the flow divider mount (2) to the HLA frame. Install the four  $1/2 \times 1-1/4$  bolts (1), the  $1/2$  washers (3), and the  $1/2$  lock nuts (4).

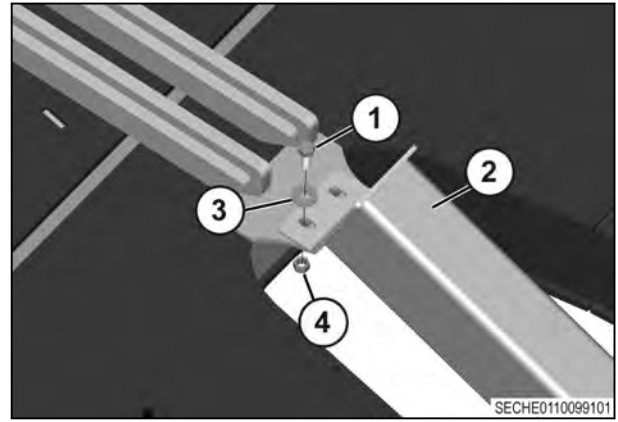

Fig. 302

4. Replace the bottom assembly (2) and install the four flange nuts (3) to the top assembly (1).

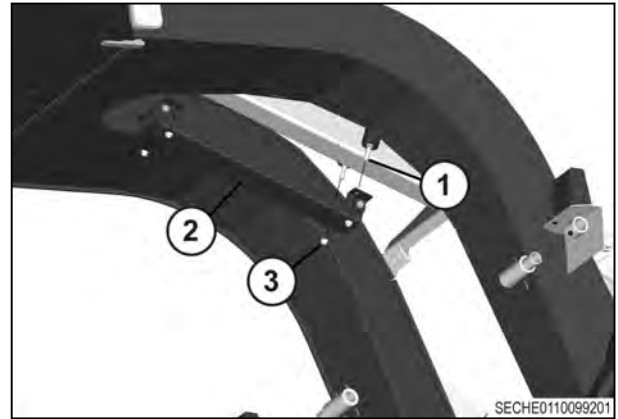

Fig. 303

5. Install the flow divider (2) on the roller assembly (3). Install the two  $3/8 \times 5 \times 3/8$  round U-bolts (1) and the four  $3/8$  flange nuts.

If the 6 inch flow divider is used, use two  $3/8 \times 6 \times 3/8$  round U-bolts.

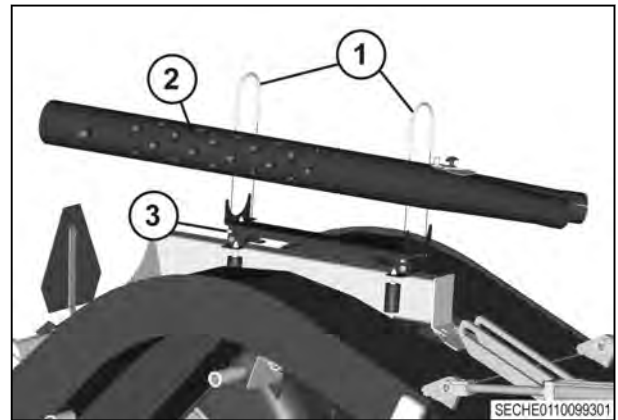
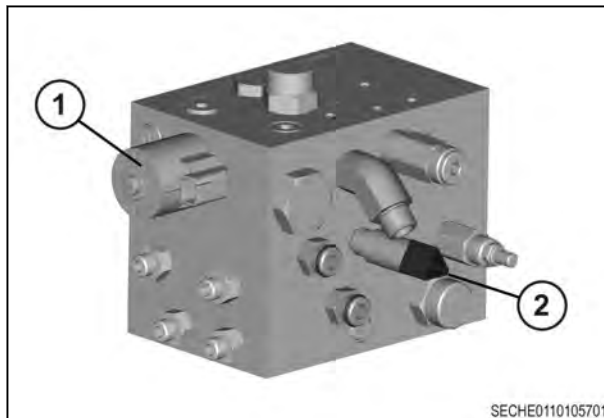

Fig. 304

### 7.8.10 Installing the down pressure harness on the hydraulic lift assist

1. Connect the down pressure harness to the solenoid (1) and the transducer (2) on the hydraulic lift assist flow divider.



SECHE0110105701

Fig. 305

2. Route the harness along the right-hand drawpole (1) and install to the hydraulic hoses.

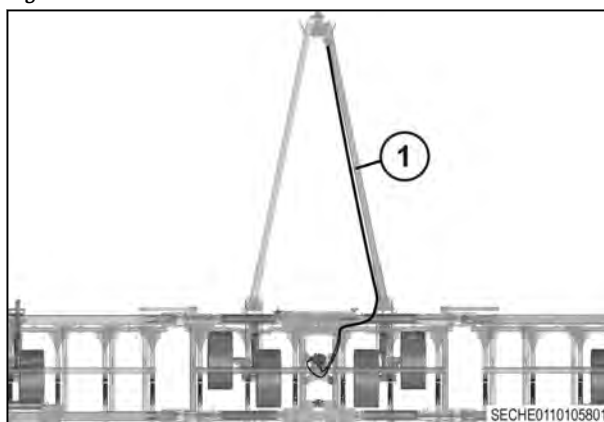

SECHE0110105801

Fig. 306

### 7.8.11 Installing the marker lamps and harness on the hydraulic lift assist

1. Install the red marker mount (2) on the rear marker lamp tube (1).

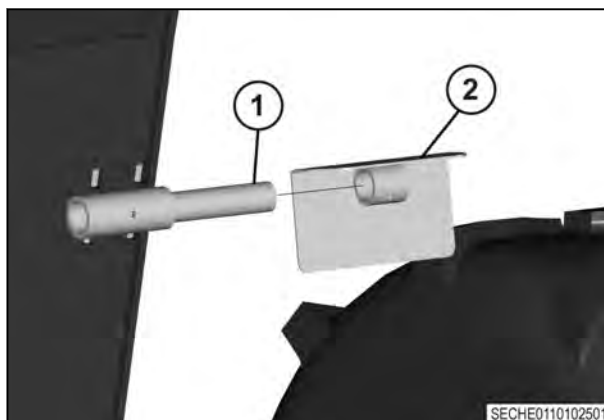

SECHE0110102501

Fig. 307

2. Install the set screw (2) and the lock washer (1) in the lamp bracket.

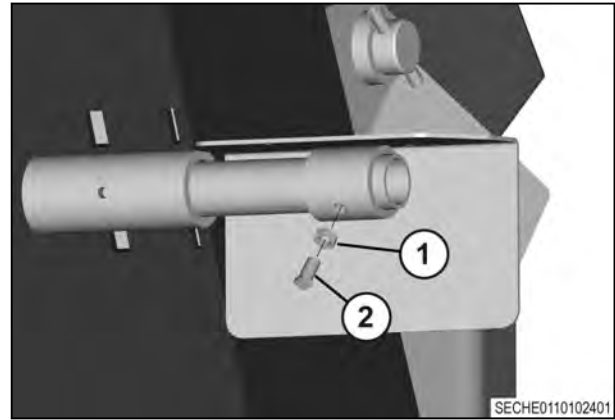

Fig. 308

3. Install the red marker lamp (2) on the lamp bracket (3). Install the two 1/4 x 1 bolts (5), the two 1/4 lock washers (4), and the two 1/4 lock nuts (1).

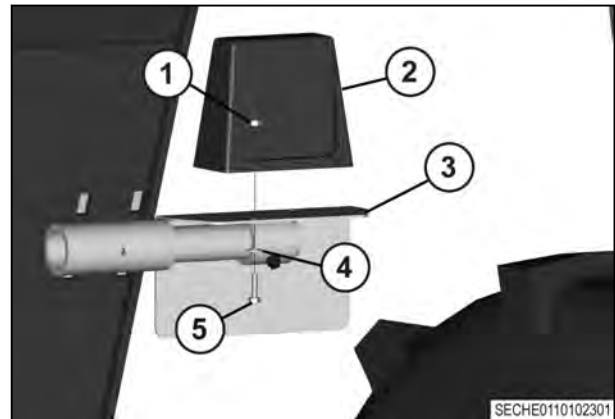

Fig. 309

4. Install the orange reflective decal (1) and the red reflective decal (2) to the back side of the light mount.

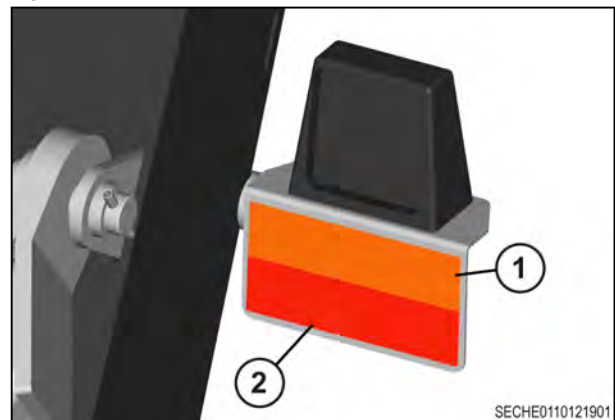

Fig. 310

5. Install the yellow reflective decal (1) to the front side of the light mount.

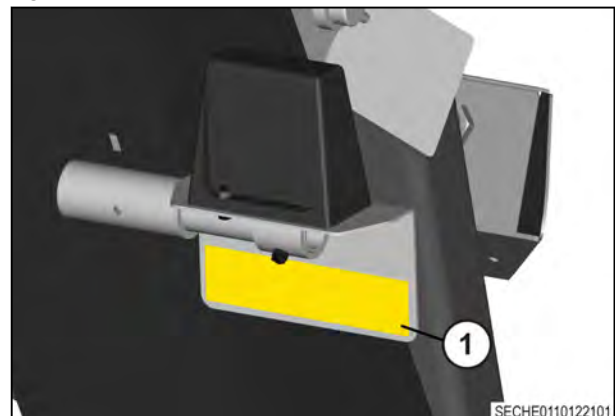

Fig. 311

6. Install the SMV sign bracket (2) to the hitch frame. Install the  $\frac{3}{8} \times 5\text{-}1/2 \times 4 \times 5\text{-}1/2$  U-bolt (6) and the two  $\frac{3}{8}$  lock nuts (5). Install the SMV sign (1) to the SMV sign bracket (2). Install the two  $1/4 \times 3/4$  bolts (4) and the two  $1/4$  lock nuts (3).

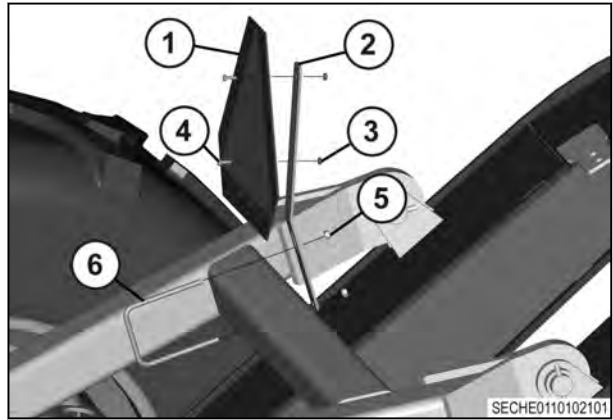

Fig. 312

7. Install the amber marker lamp bracket (1) to the main frame mount (3). Install the two  $1/2 \times 1$  bolts (2) and the  $1/2$  lock nuts (4).

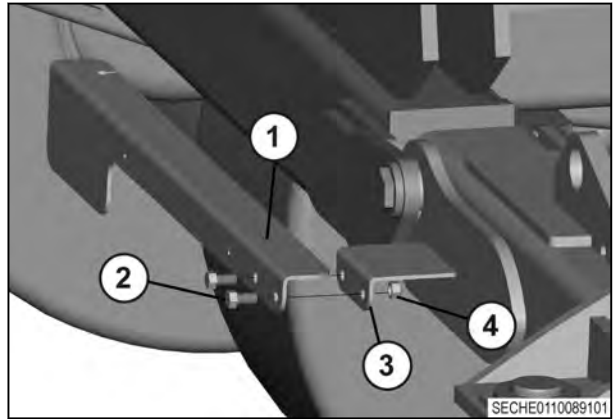

Fig. 313

8. Install the amber marker lamp (1) to the amber marker lamp bracket (2) with the mounting nut (3).

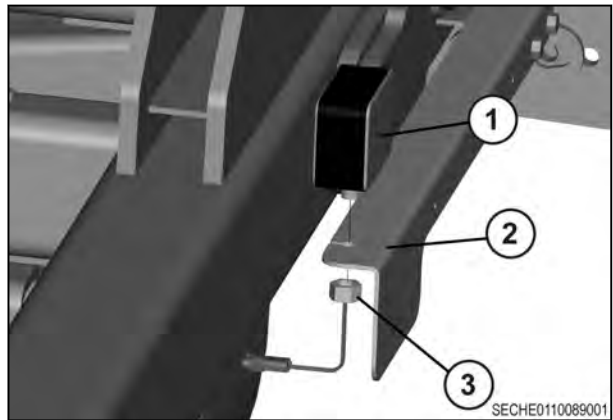

Fig. 314

9. Install the yellow reflective decal (1) to the front side of the light mount.

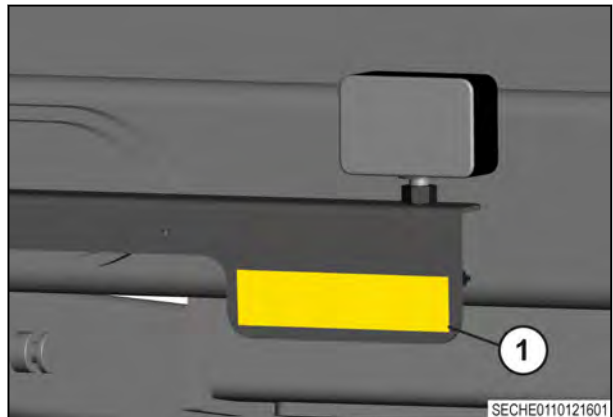

Fig. 315

10. Install the orange reflective decal (1) and the red reflective decal (2) to the back side of the light mount.

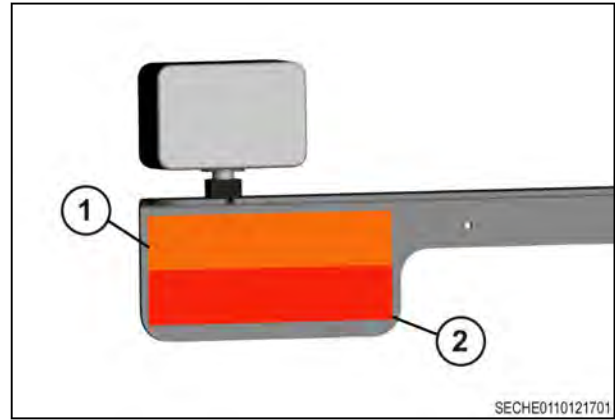

Fig. 316

11. Install the bracket mount (3) and backing plate (2) to the main frame. Install the two 3/8 x 7-1/2 bolts (4) and the two 3/8 lock nuts (1).

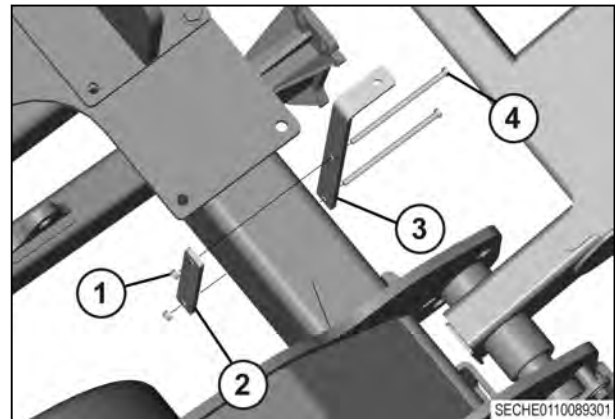

Fig. 317

12. Install the interface module bracket (2) to the bracket mount (3). Install the 3/4 x 1-1/4 bolt (1) and the 3/4 lock nut (4).

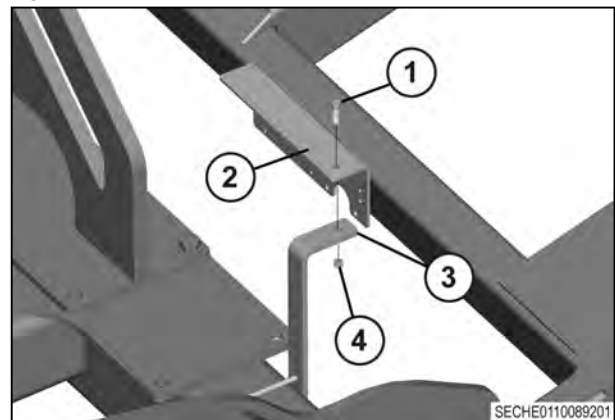

Fig. 318

13. Install the interface module (2) to the mounting bracket (3). Install the four 3/16 x 3/4 screws (1) and the 3/16 nuts (4).

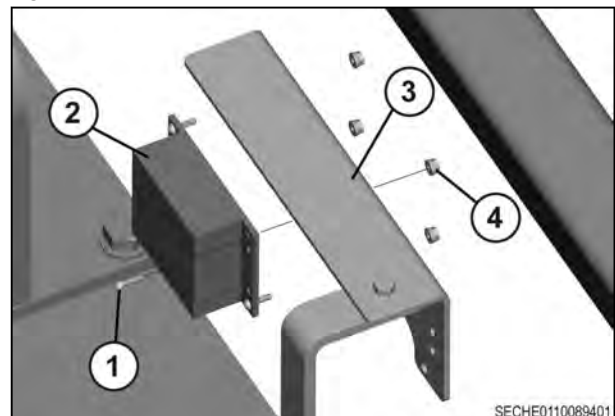

Fig. 319

- 14. Remove the cover (1) from the rear marker lamp harness.

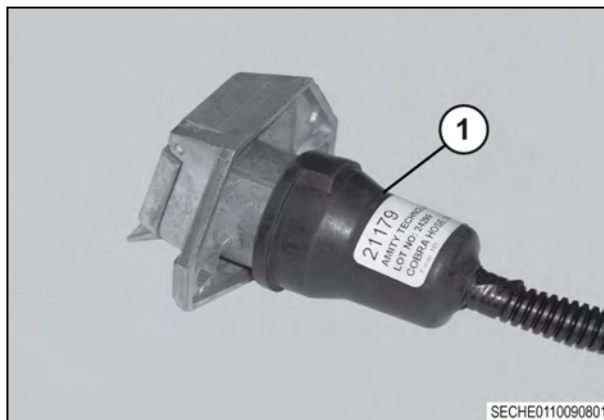

Fig. 320

- 15. Remove the set screw (1) from the harness connector.

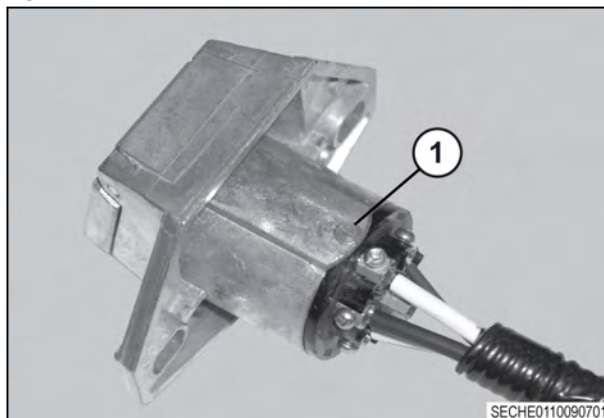

Fig. 321

- 16. Remove the male pins (1) from the connector.

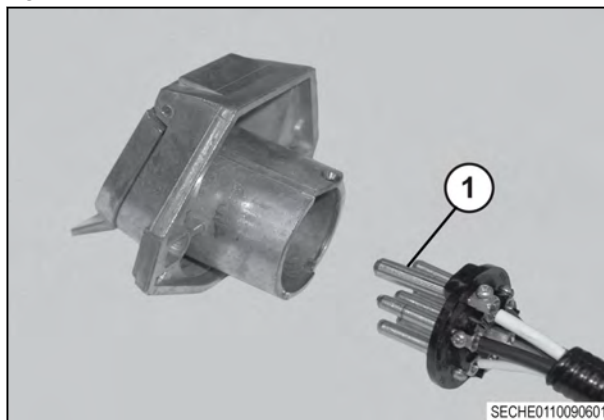

Fig. 322

- 17. Install the connector (1) to the bulkhead with the two 5/16 x 1 bolts (2) and the 5/16 lock nuts.

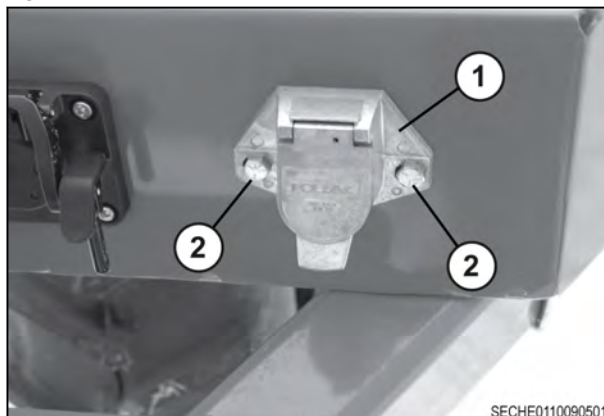

Fig. 323

18. Install the male pins (2) in the connector housing and replace the set screw (1).

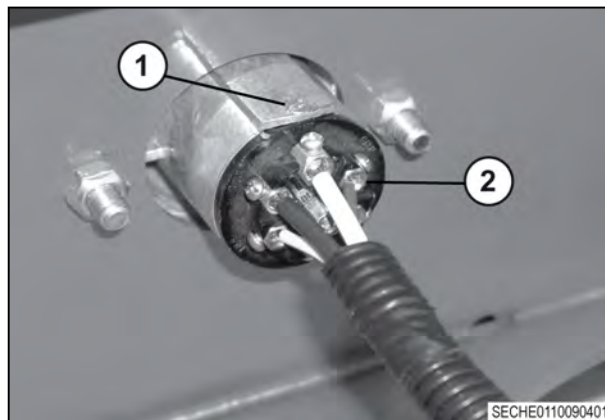

Fig. 324

19. Replace the cover (1) on the back of the connector.

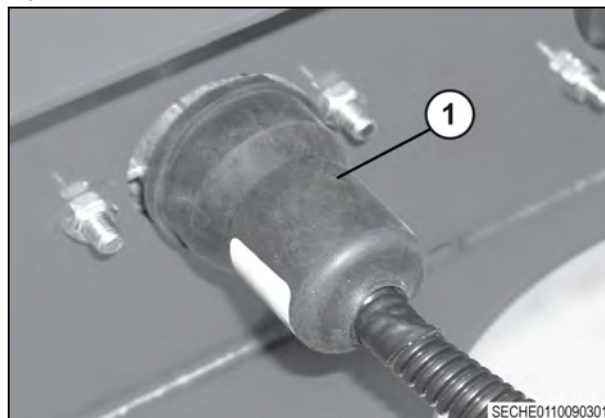

Fig. 325

20. Install the front marker lamp harness (1) to the mounting bracket. Install the 5/16 x 1 bolts (2) and 5/16 nuts. Connect the rear marker lamp harness (3) to the front marker lamp harness.

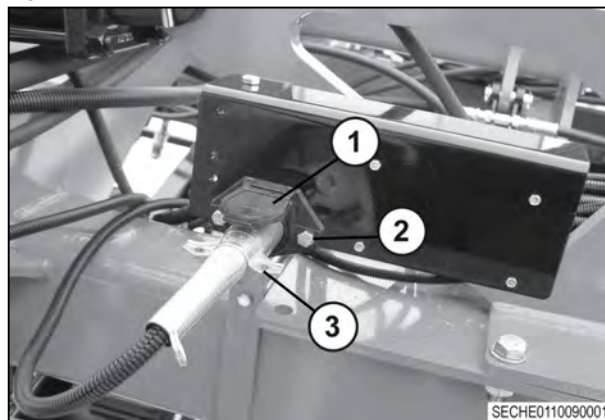
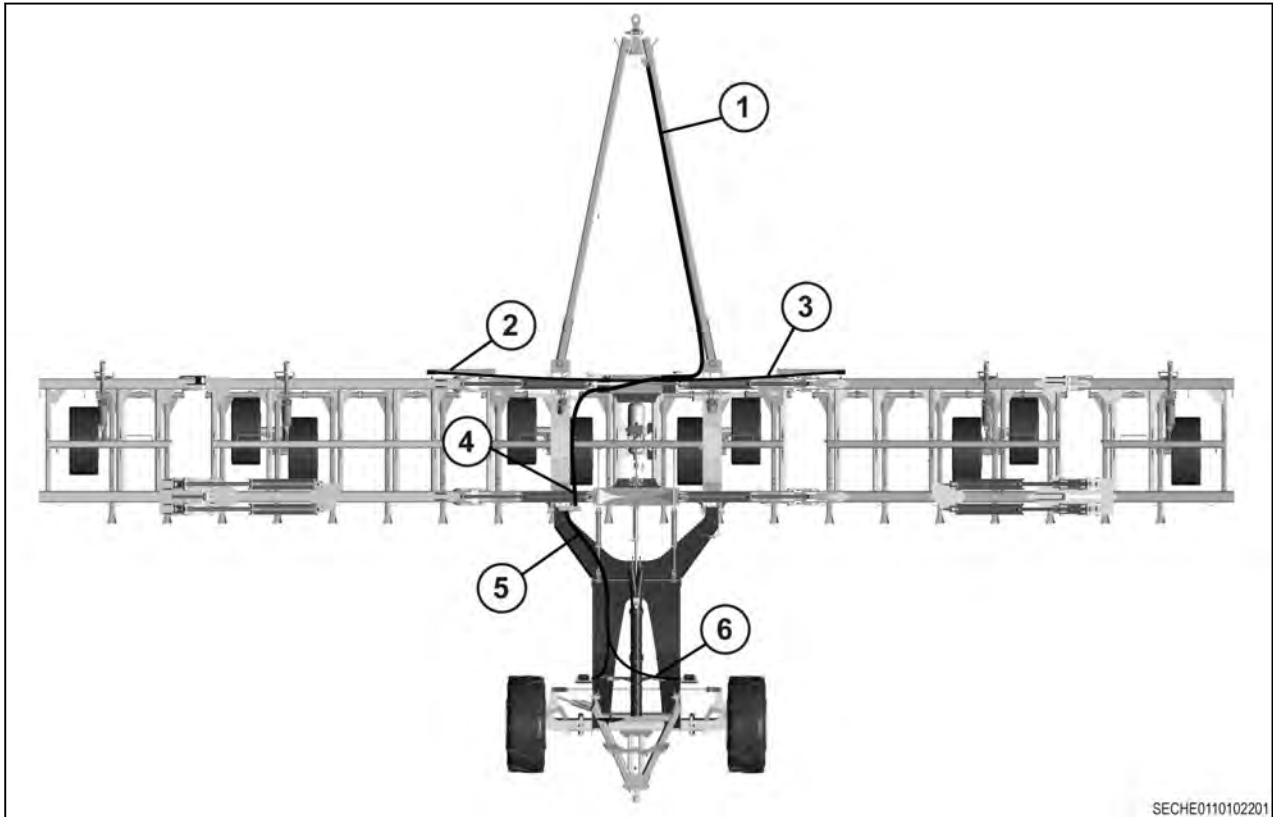

Fig. 326





SECHE0110102201

Fig. 327

21. Route the rear marker lamp harness along the left-hand side of the rear hitch (5) and connect to the front harness (4).
22. Route the front harness along the left-hand main frame to the right-hand drawpole. Install the harness to the hydraulic hoses to the light socket cap (1).
23. Connect the left-hand (2) and right-hand hazard lights (3) to the front lamp harness and route along the front of the main frame.
24. Install all of the wires to the hydraulic hoses.

### 7.8.12 Installing the main ISO harness on the hydraulic lift assist

1. Connect the main ISO harness connectors (1) (2) to the IBBC connector on the bulkhead.

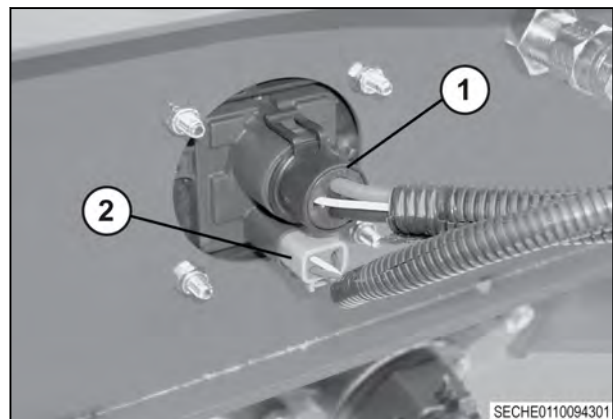
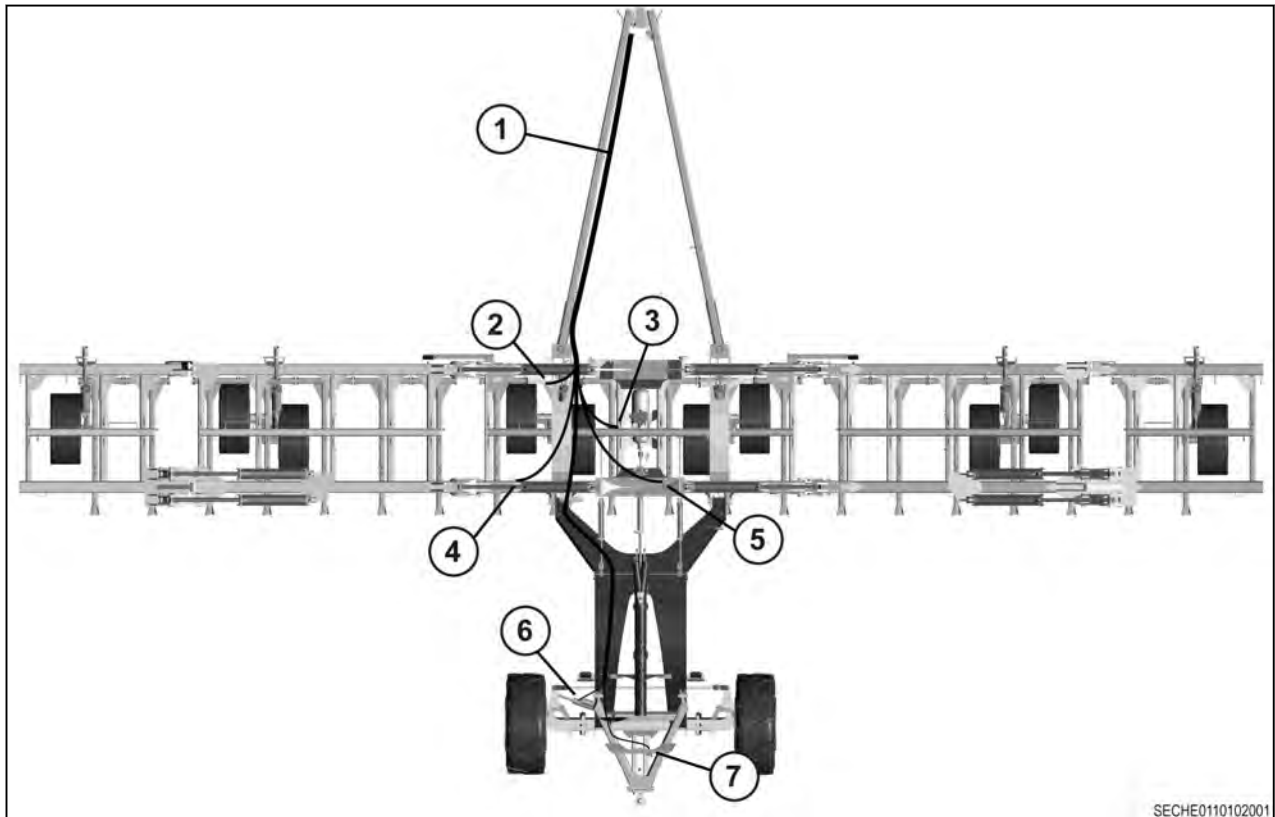

Fig. 328

SECHE0110094301





SECHE0110102001

Fig. 329

2. Route the harness along the left-hand hydraulic lift assist frame and the left-hand drawpole (1). Install the harness to the hydraulic hoses.
3. Connect the work switch harness (2).
4. Connect the NH3 module (3).
5. Connect the left-hand wireless blockage monitor harness (4).
6. Connect the right-hand wireless blockage monitor harness (5).
7. Connect the hydraulic caster lock harness (6).
8. Connect the IBBC connections (7).

## 7.9 Installing the secondary flow dividers

### Procedure

1. Install the 4 x 3 flow divider (1) to the main splitter using two 4 inch muffler clamps (2).
2. Install the 3 inch 45° elbows (3) on the inside runs with the 3 inch muffler clamps (4).
3. Install the 3 inch 30° elbows (5) on the outside runs with the 3 inch muffler clamps (4).

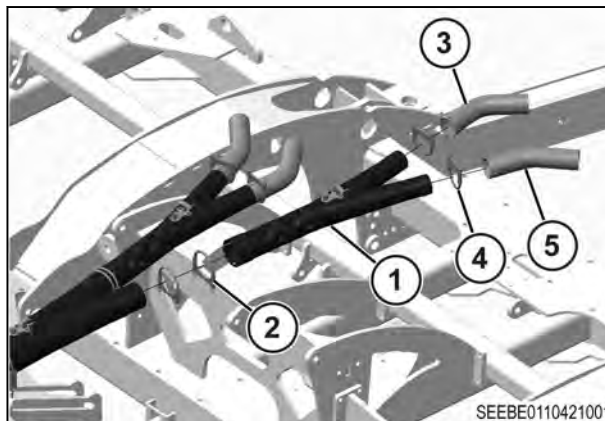

Fig. 330

## 7.10 Installing the dual flow dividers

### 7.10.1 Installing the dual hitch mounted flow dividers

Install the mounting brackets (3) between the two flow dividers (2). Install the U-bolts (1) over the divider tube (2), in the bracket (3), and tighten the lock nuts (4).

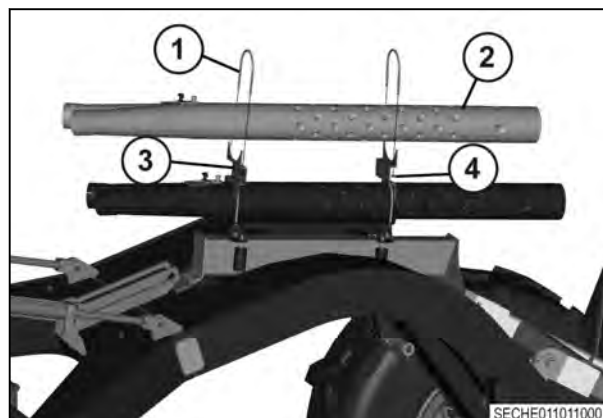

Fig. 331

## 7.11 Installing the wireless blockage monitor system

### 7.11.1 Installing the wireless blockage monitor

1. Install the ECU bracket (5) to the seed tower (3) with the U-bolts (2), the saddle clamps (4), and the lock nuts (1).

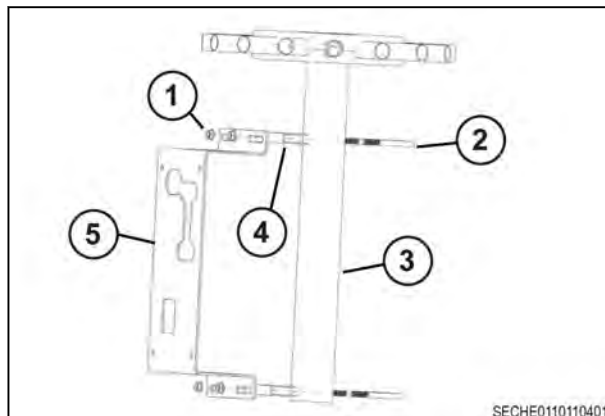

Fig. 332

2. Install the ECU (1) in the bracket with the four bolts (3) and nuts (2).

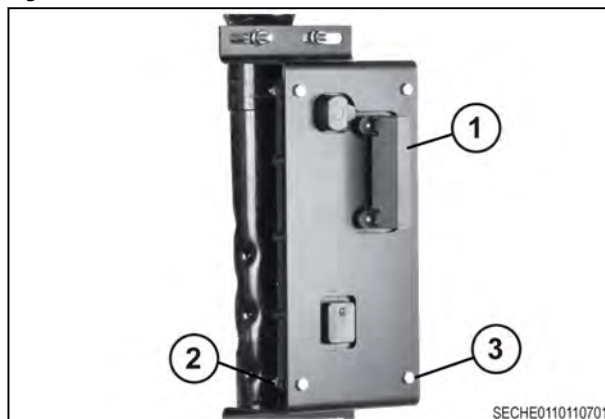

Fig. 333

3. Install the shields (1) to the bracket with the four cotter pins (2).

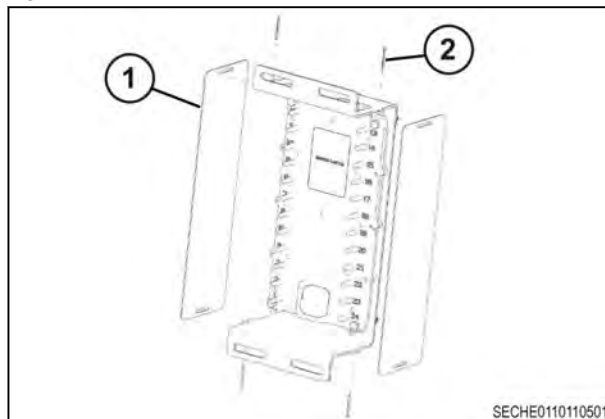
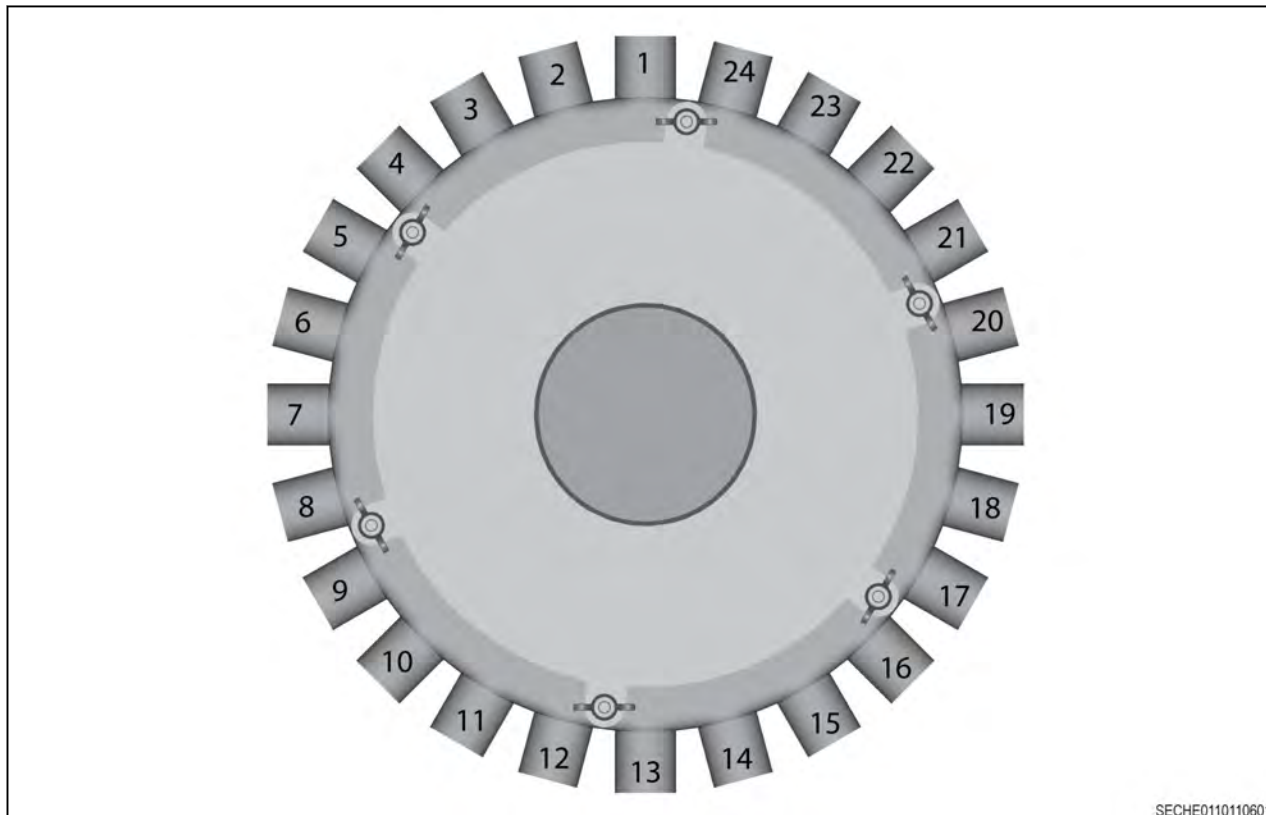

Fig. 334

### 7.11.2 Installing the blockage sensors



SECHE0110110601

Fig. 335

1. Write the port numbers on the manifolds with 1 through 24 in a counterclockwise direction.
2. Indicate blocked or unused ports.
3. Install the clamps (1) to the manifold ports and the short hose (2). Install the second clamp (1) to the short hose (2) and the blockage sensor (3).

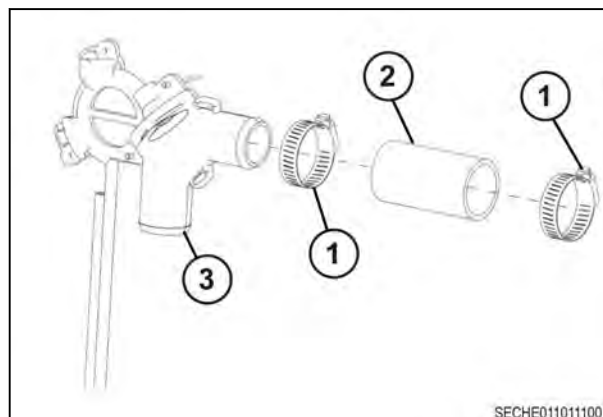

SECHE0110111001

Fig. 336

4. Install the wire to the blockage sensor (1) and route wire to the back of the ECU (2).

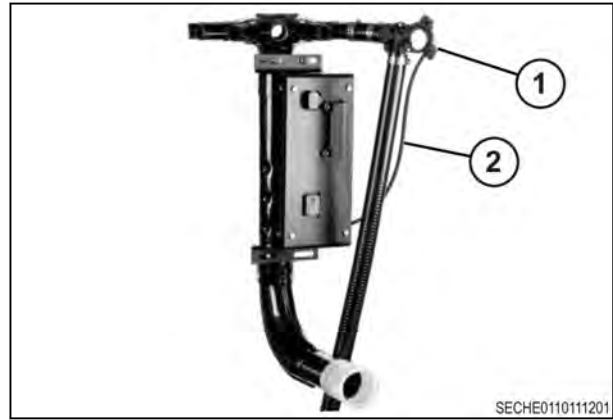

Fig. 337

5. Connect the blockage sensor wire to the corresponding port (2) on the back of the ECU (1).



Fig. 338

### 7.11.3 Installing the wireless blockage monitor harness

#### Procedure

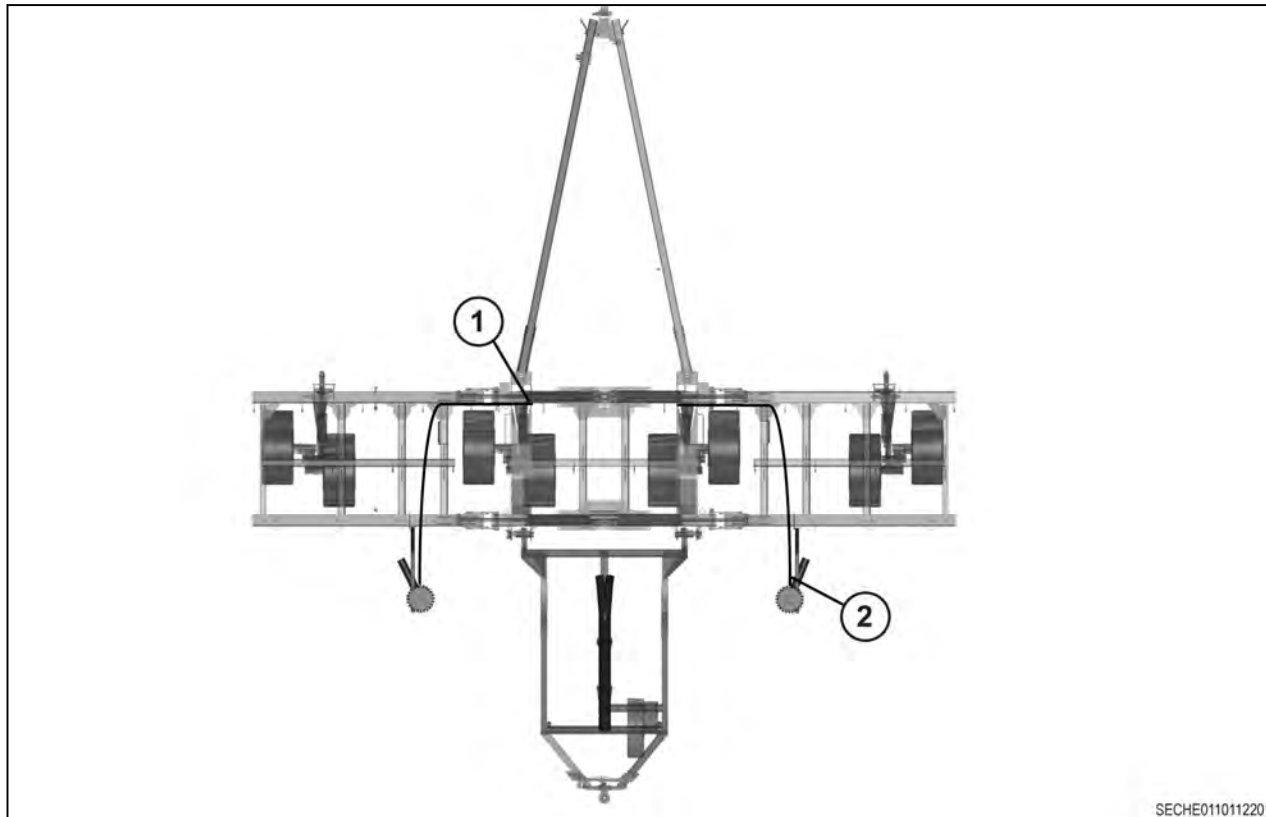

Fig. 339

1. Connect the left-hand and the right-hand harnesses to the wireless blockage monitors (2) and route along frame to the main ISO harness connections (1).

**NOTE:**

*30 ft frame has two zones and towers.*

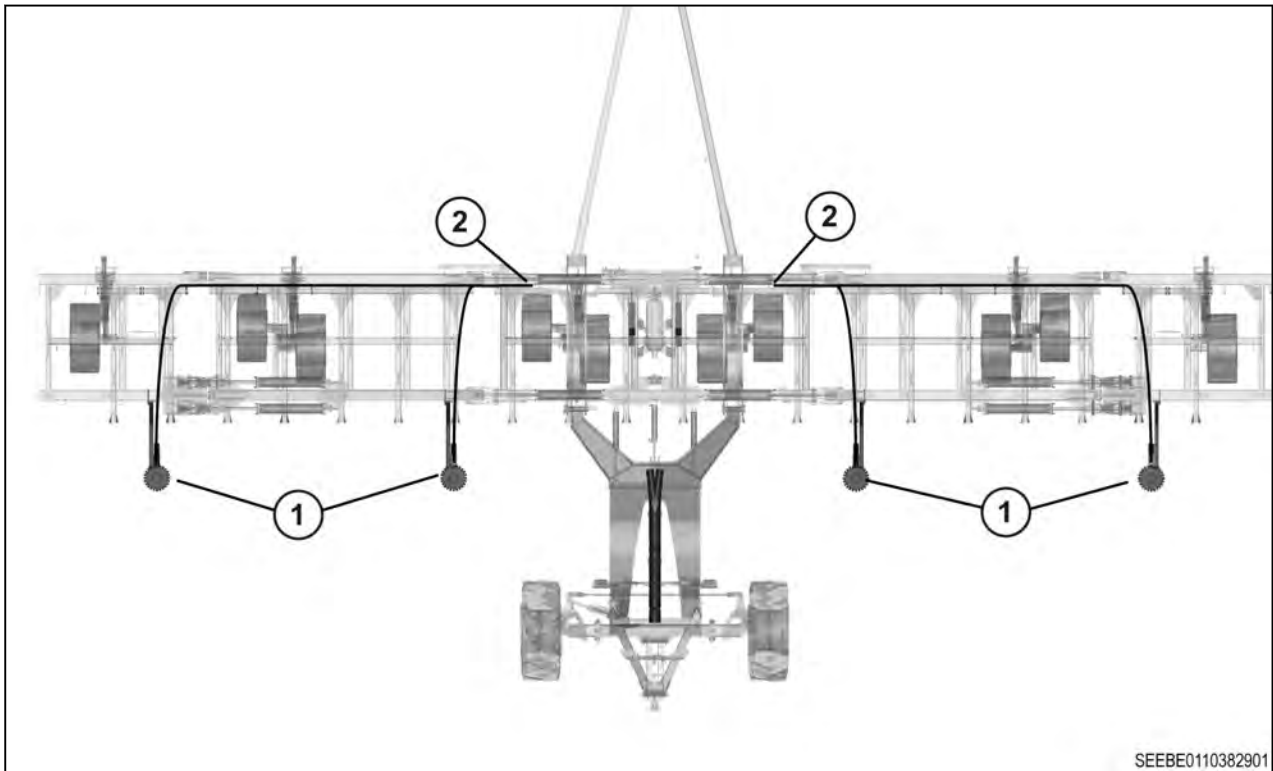

Fig. 340

2. Connect the left-hand and the right-hand harnesses to the wireless blockage monitors (1) and route along frame to the main ISO harness connections (2).



## 7.12 Installing the seed delivery system

### 7.12.1 Assembling the seed tower manifold

1. Install the flange (5) between the manifold head (4) and the lock collar (7). Install the rubber pad (3) in the distributor lid (2). Install the bolts (6) and wing nuts (1).

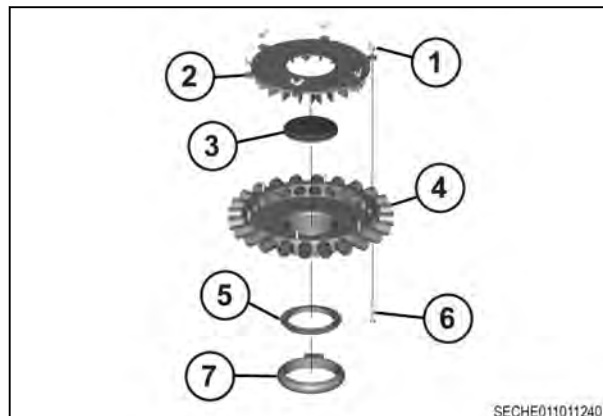

Fig. 341

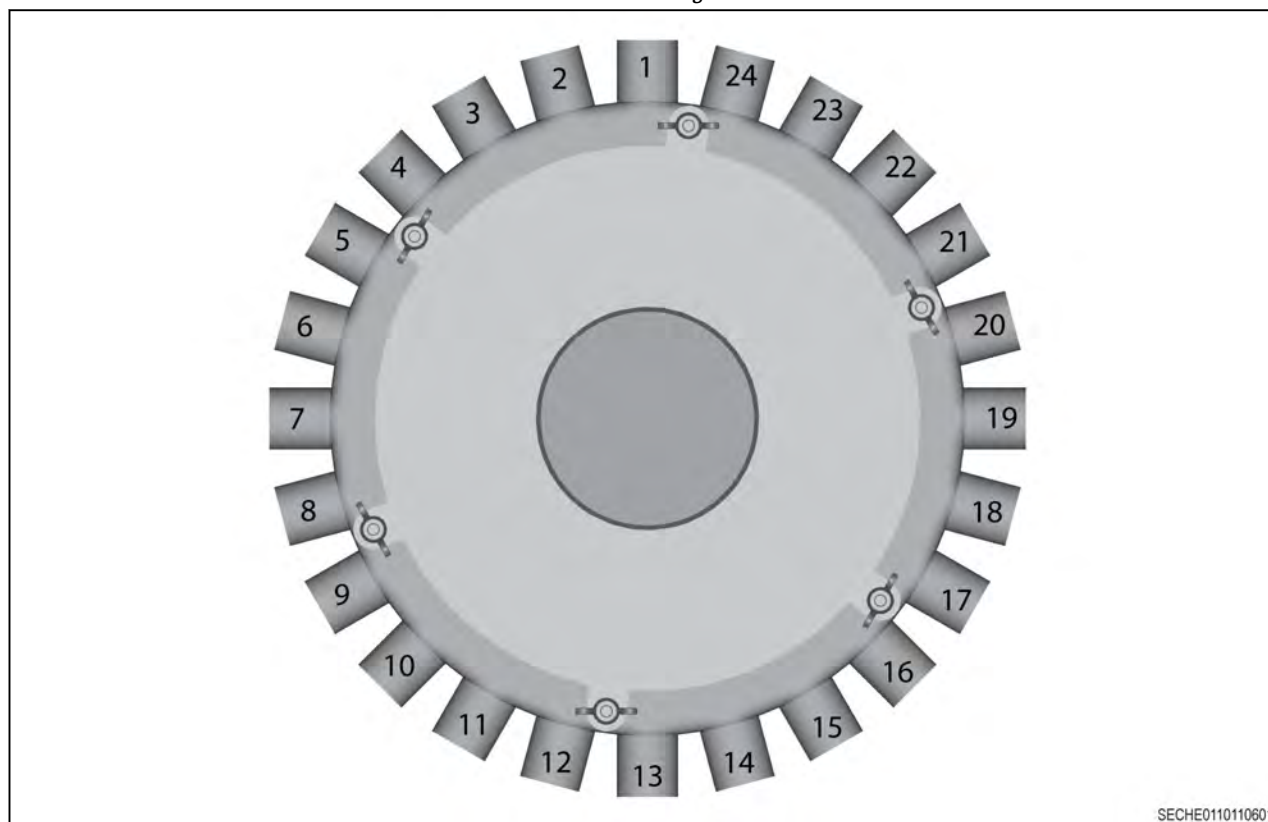
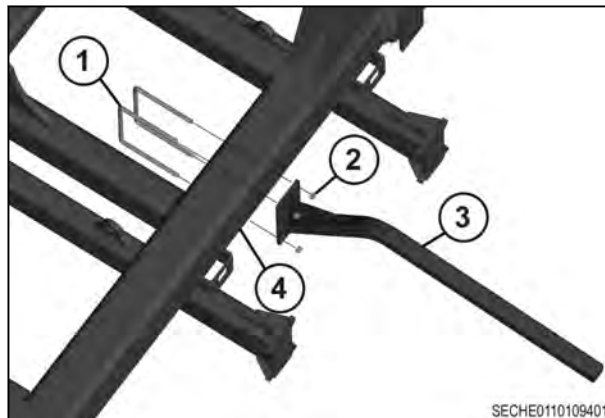

Fig. 342

2. Write the numbers 1 through 24 on the ports in a counterclockwise direction.

## 7.12.2 Installing the 2 zone seed towers

1. Install the seed tower arm (3) to the rear of the main frame (4). Install the arm with the two  $1/2 \times 7-1/2 \times 8 \times 7-1/2$  U-bolts (1) and the four  $1/2$  lock nuts (2).



SECE0110109401

Fig. 343

2. Install the tower bracket (1) to the arm (3). Install the  $1/2 \times 3 \times 2 \times 3$  U-bolts (4), flat washers (5) and  $1/2$  lock nuts (2).

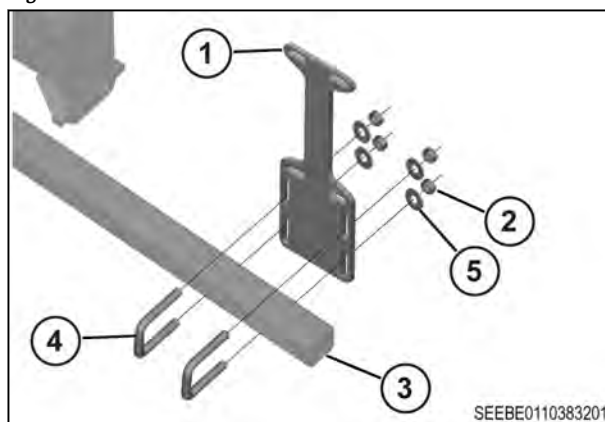

SEEBE0110383201

Fig. 344

3. Install the tower tube (4) to the bracket (2). Install the two  $3/8 \times 4 \times 1/4 \times 5 \times 7/8$  round U-bolts (3), muffler clamps (5), and  $3/8$  flange nuts (1).

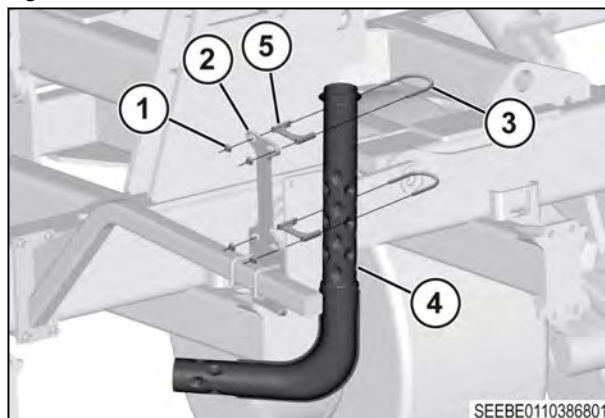

SEEBE0110386801

Fig. 345

4. Install the manifold assembly (1) on the flange (2).

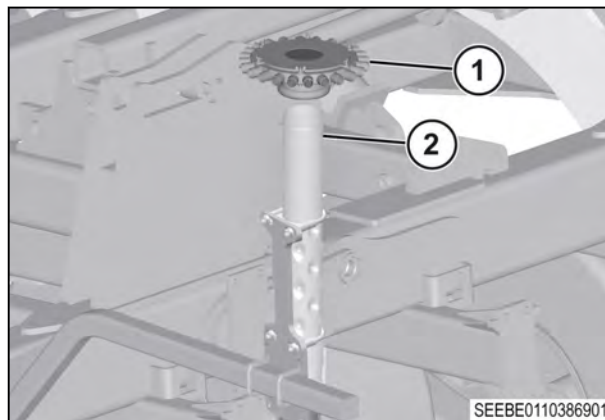

Fig. 346

5. Install the hose holder (1) over the rear cylinder mount pins (3) and replace the roll pins (2).

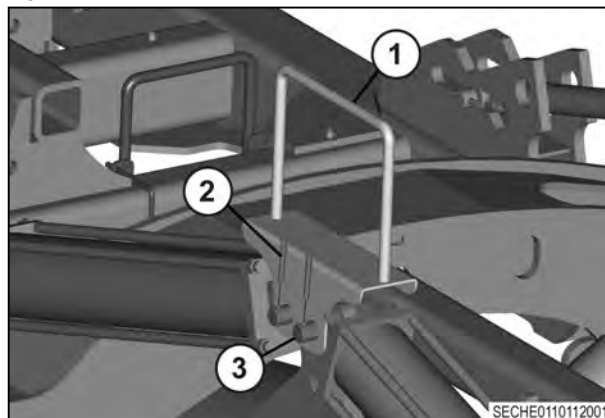

Fig. 347

6. Install the wing mounted hose holder (3) with the two 3/8 x 5 x 6 x 5 U-bolts (1) and the four 3/8 lock nuts (2).

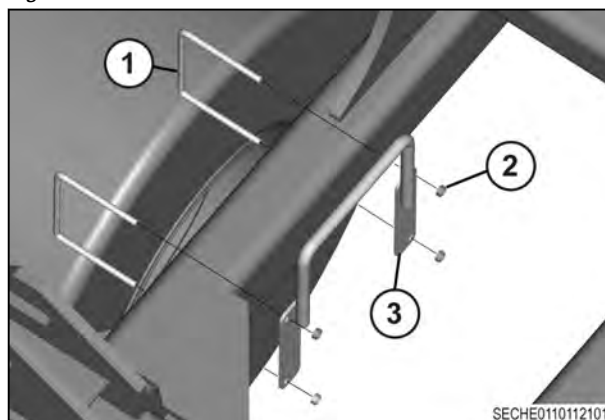
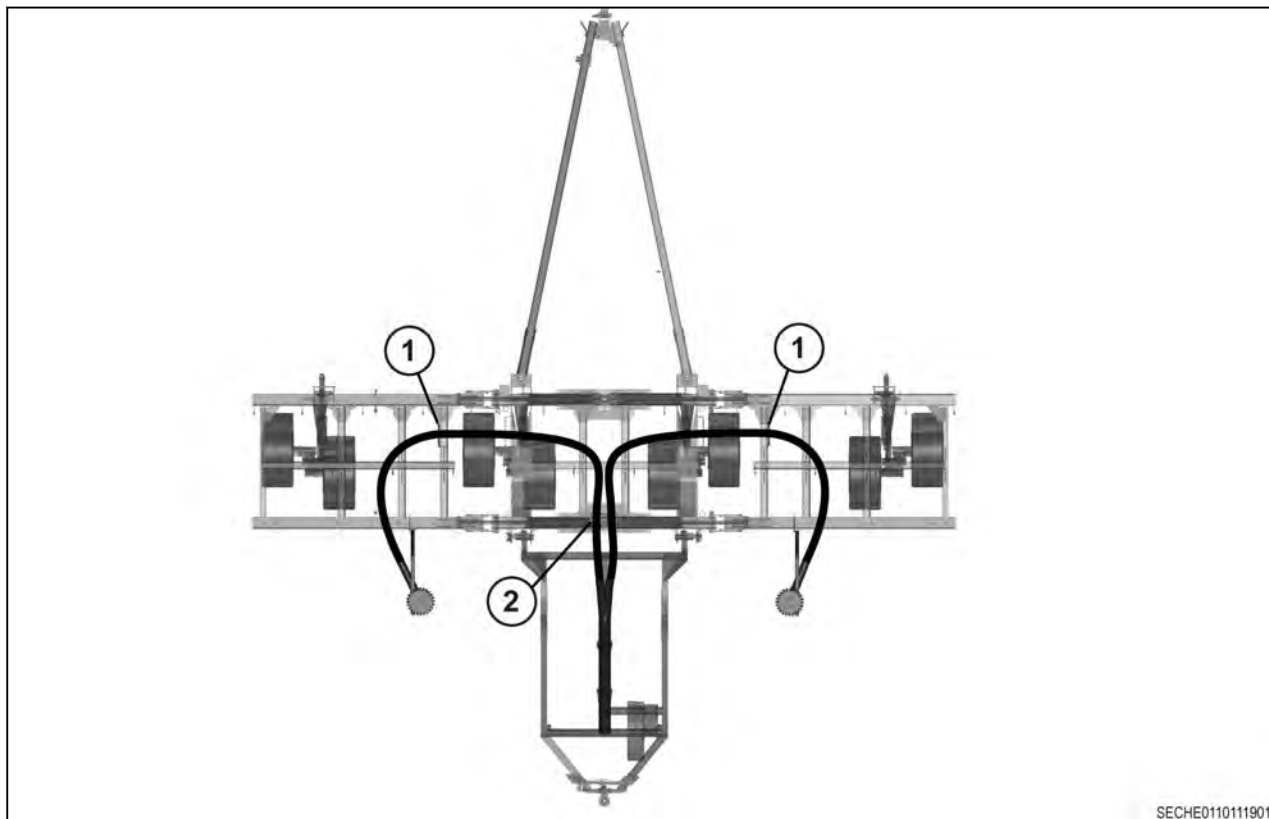

Fig. 348



SECHE011011901

Fig. 349

7. Install the flex hoses to the seed towers and the hitch flow divider and cut the hoses to length. Route the hoses under the hose holders (1) (2).
8. Install the clamps (3) on each hose (2) and seed tower (1).
9. Install the hoses and clamps on the hitch mounted flow divider.

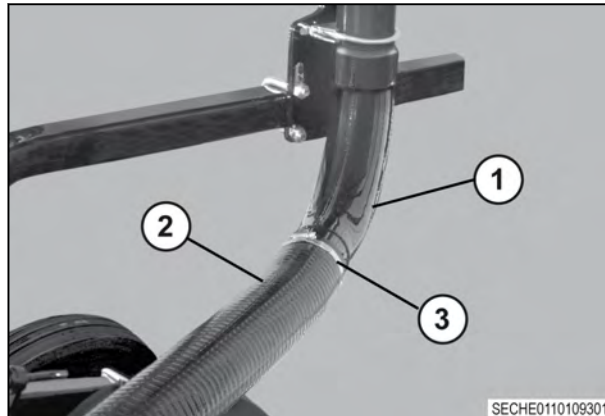

SECHE0110109301

Fig. 350

### 7.12.3 Installing the 4 zone seed towers

1. Install the seed tower arm (3) to the rear of the main frame (4). install the two  $1/2 \times 7-1/2 \times 8 \times 7-1/2$  U-bolts (1) and the four  $1/2$  lock nuts (2).

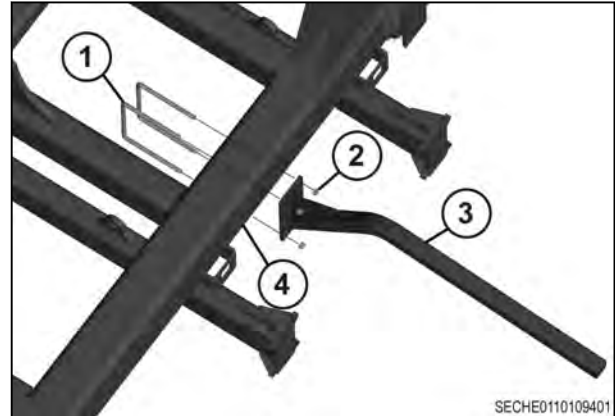

Fig. 351

2. Install the tower bracket (1) to the arm (3). Install the  $1/2 \times 3 \times 2 \times 3$  U-bolts (4), flat washers (5) and  $1/2$  lock nuts (2).

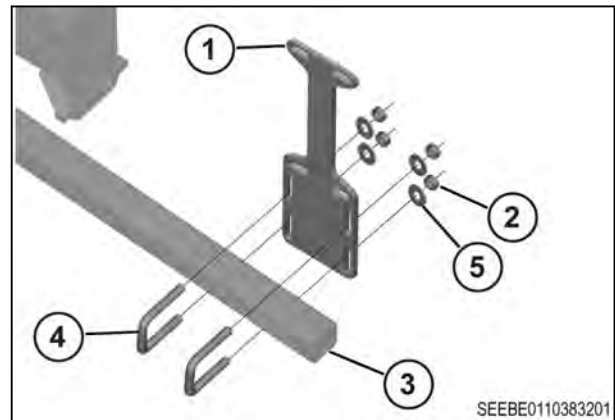

Fig. 352

3. Install the tower tube (4) to the bracket (2). Install the two  $3/8 \times 3 \ 3/16 \times 4 \ 1/2$  round U-bolts (3), muffler clamps (5), and  $3/8$  flange nuts (1) .

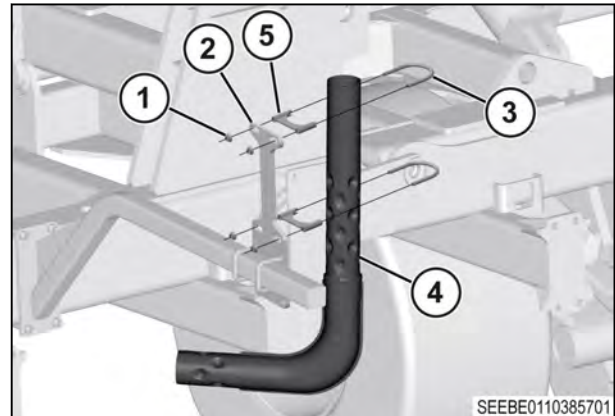

Fig. 353

4. Install the reducer (1) on the seed tower tube (2) using  $3/8 \times 3 \ 3/16 \times 4 \ 1/2$  round U-bolts (3), muffler clamps (5) and  $3/8$  flange nuts (4).

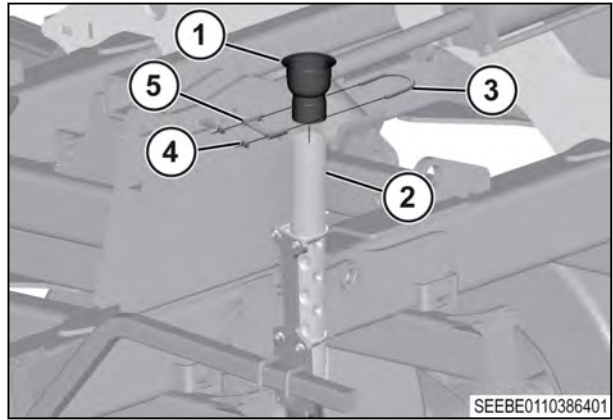

Fig. 354

5. Install the manifold assembly (1) on the reducer (2).

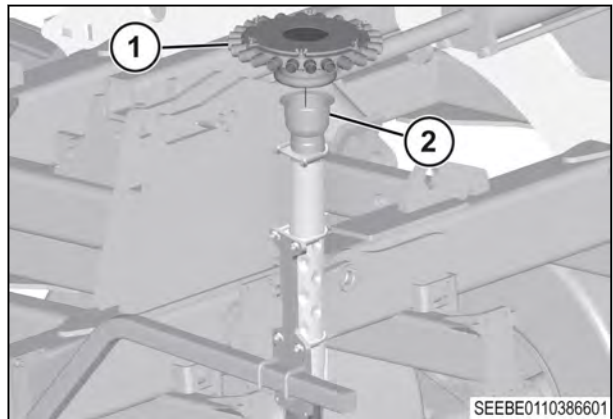

Fig. 355

6. Use a level (1) to level the flow divider tubes.

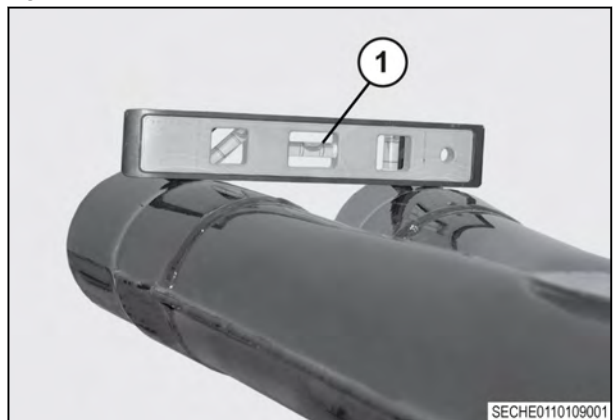
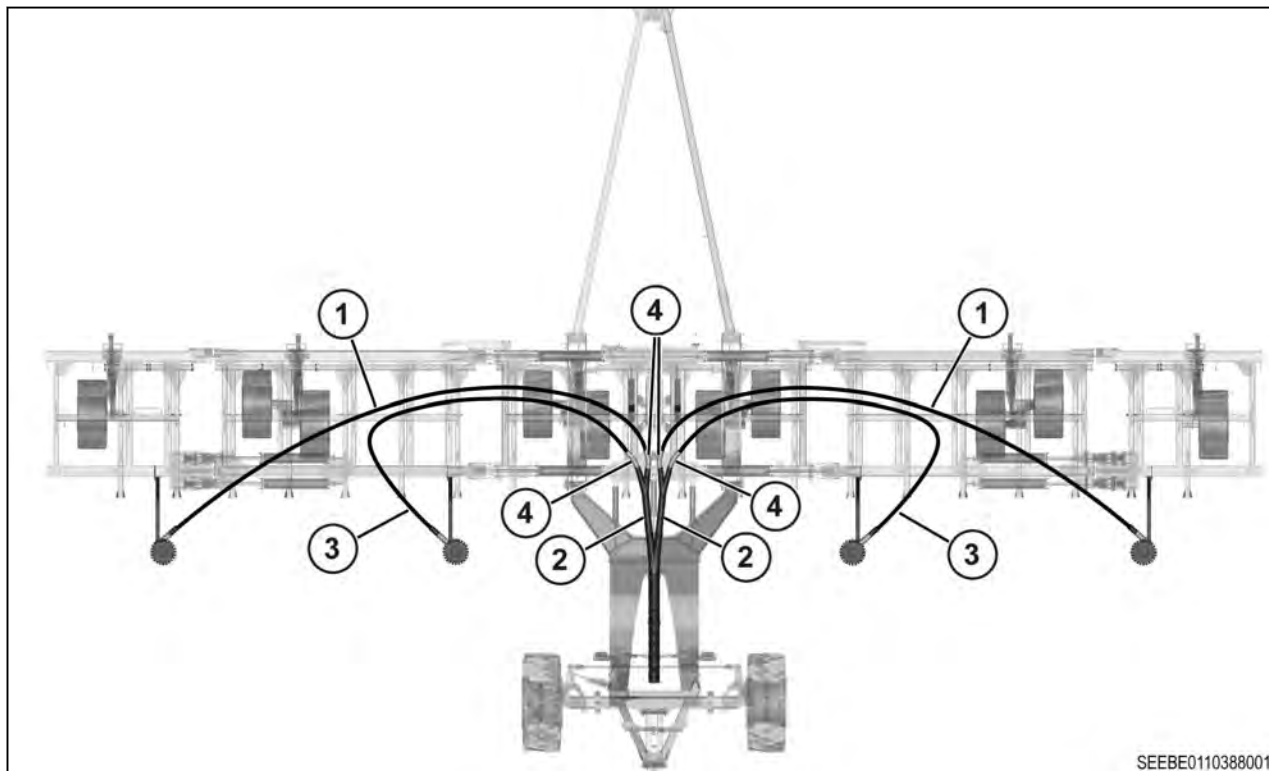

Fig. 356





SEEBE0110388001

Fig. 357

7. Install the flex hoses (1) (3) to the seed towers and the elbows (4) on the flow dividers (2).
8. Clamp the flex (1) hoses to the Y ends of the flow dividers (2). Route the hoses to the seed towers and cut the hoses to length.

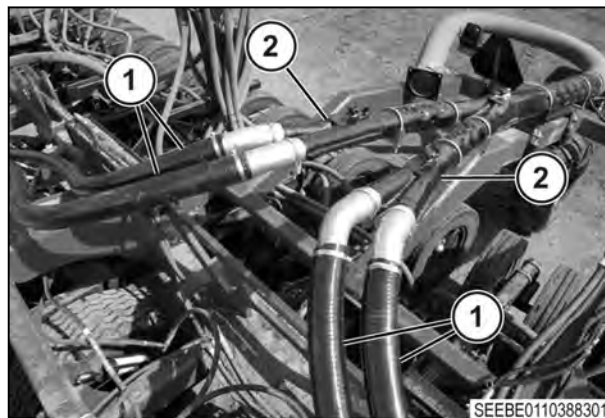

SEEBE0110388301

Fig. 358

9. Install the clamps (3) on each hose (2) and seed tower (1).

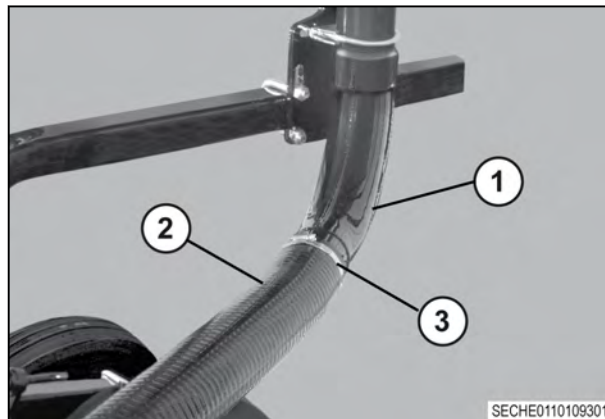

SECHE0110109301

Fig. 359

10. Install the four stainless steel torcite clamps. The thin flange (1) of the tightener block must be against the tube. The thick flange (2) is against the band tightener pins (3).
11. Tighten the two bolts (4) on each clamp.

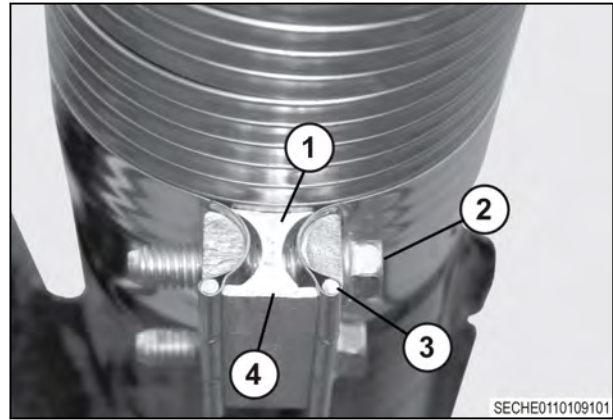

Fig. 360

### 7.12.4 Routing the seed delivery hoses

#### Before starting the procedure

Make sure the frames are raised all the way up and the toolbars are all the way down when routing hoses.

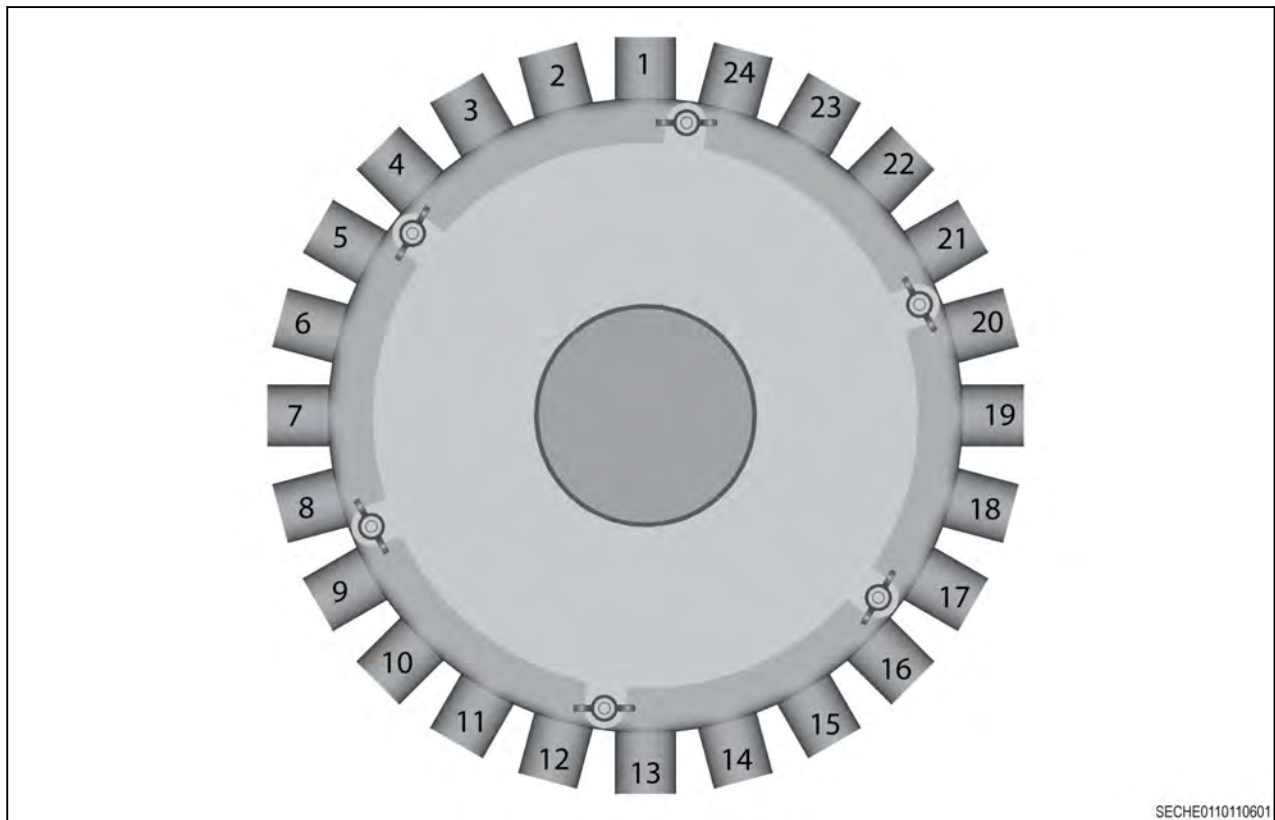

Fig. 361

1. Write the numbers 1 through 24 on the ports in a counterclockwise direction.
2. Indicate the blocked or unused ports.



3. The open ports (1) will be marked as a thin line with the corresponding port number.
4. The blocked ports (2) will be marked as a thick line with the corresponding port number.
5. The flex hoses (3) will be the thin line between the numbered port (1) and the forward (5) or rear disc opener (4).

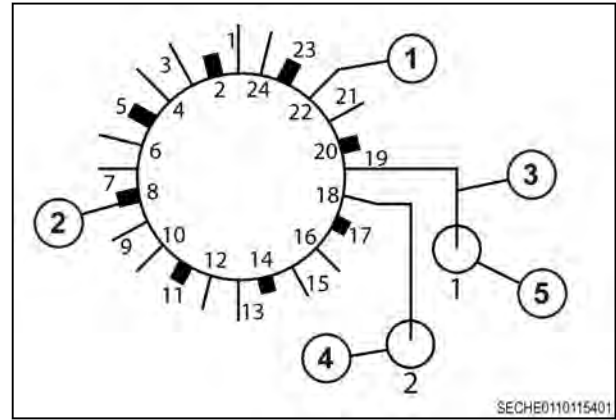

Fig. 362

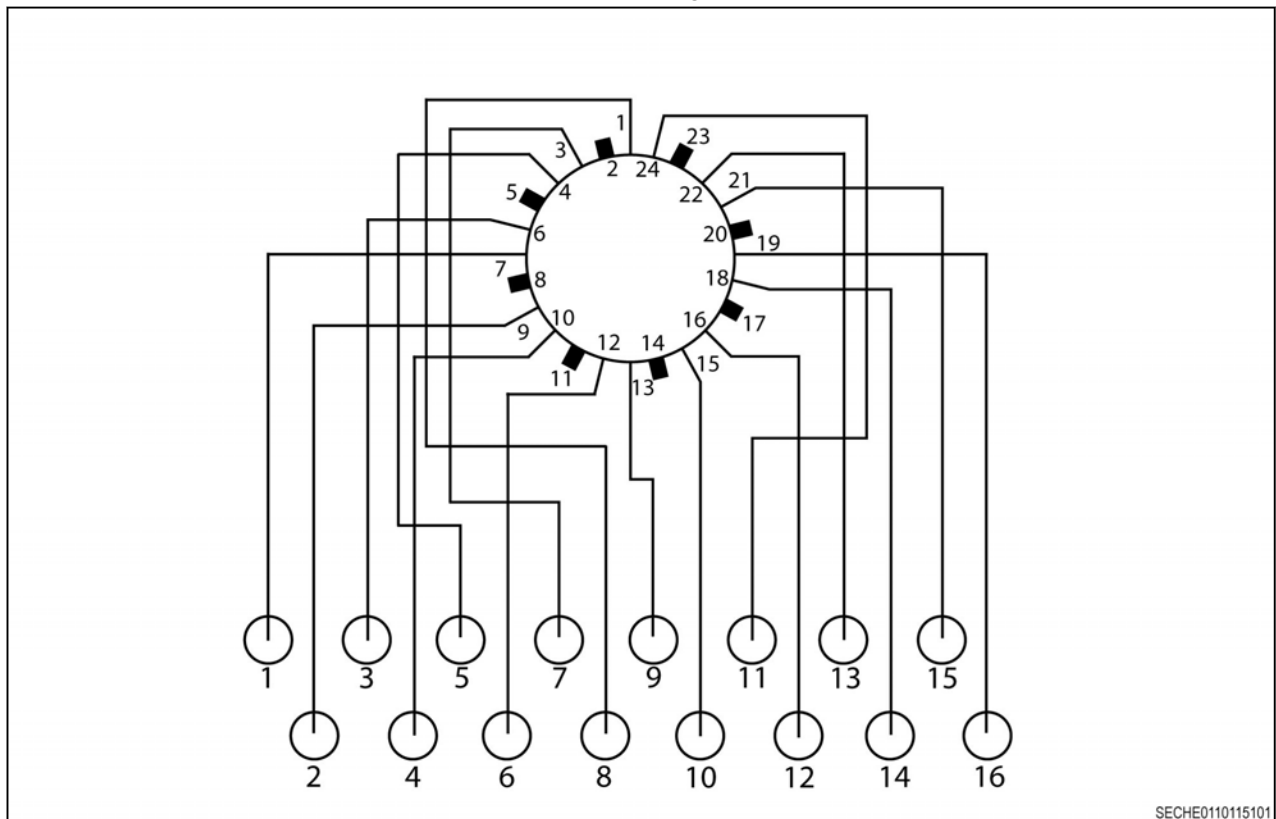
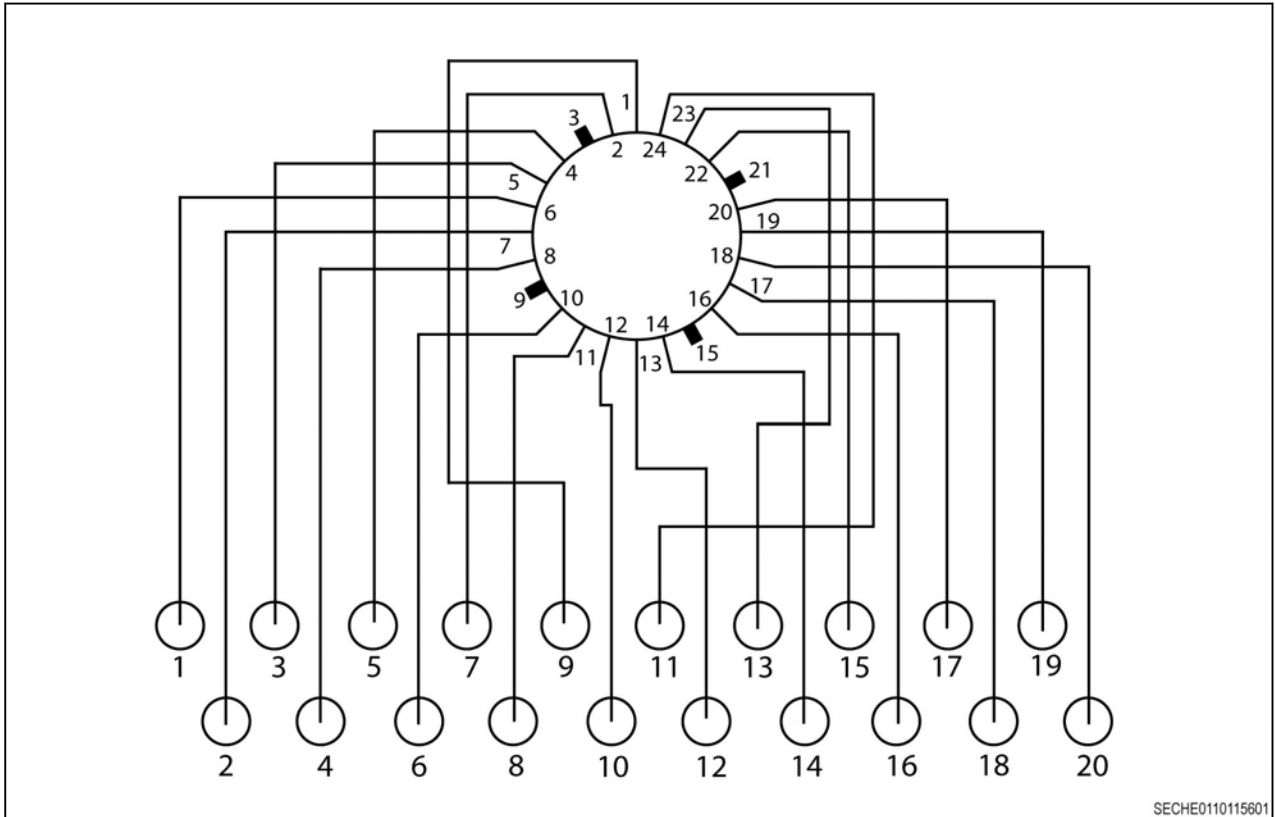

Fig. 363

6. Route the 40 ft drill from the left-hand side to the right-hand side as shown.



SECHE0110115601

Fig. 364

7. Route the 50 ft drill from the left-hand side to the right-hand side as shown.

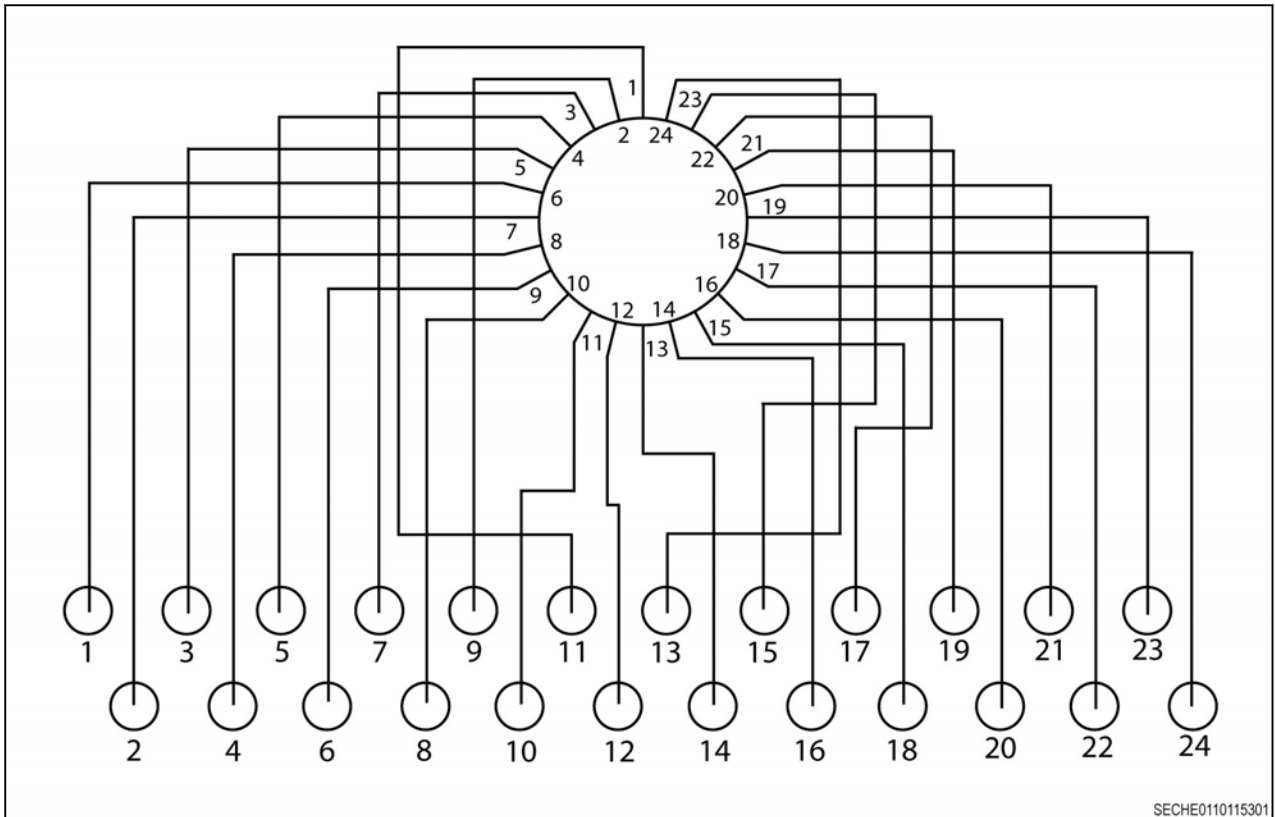

SECHE0110115301

Fig. 365

8. Route the 30 ft and 60 ft drill from the left-hand side to the right-hand side as shown.

## 7.12.5 Installing the seed delivery hoses

### Before starting the procedure

Make sure the frames are raised all the way up and the toolbars are all the way down when routing hoses.

1. Install the 1-1/4 seed hose and tighten the clamp (1) to the blockage sensor.

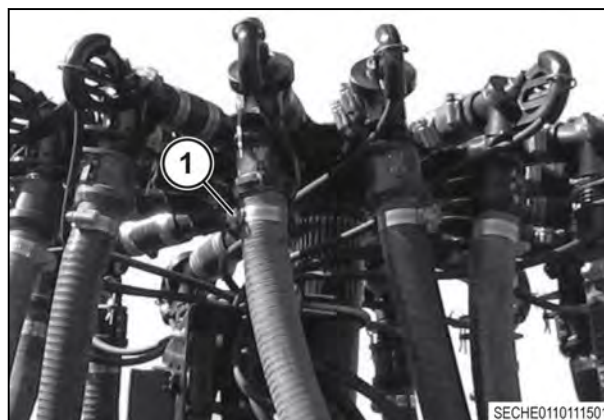

Fig. 366

2. install the 1-1/4 seed hose and tighten the clamp (1) to the seed tube.

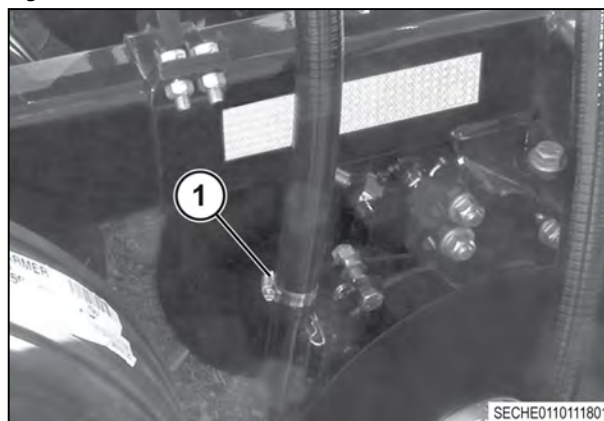

Fig. 367

## 7.13 Installing the fertilizer bander

### 7.13.1 Installing the fertilizer bander assembly

1. Install the fertilizer bander assembly to the toolbar frame. Install the four  $5/8 \times 2-1/2$  bolts (2), the  $5/8$  washers (3), and the  $5/8$  flange nuts (1).
2. Install the toolbar to the bander. Install the four  $5/8 \times 2-1/2$  bolts (7), the eight  $5/8$  washers (6) (5), and the four  $5/8$  nuts (4).

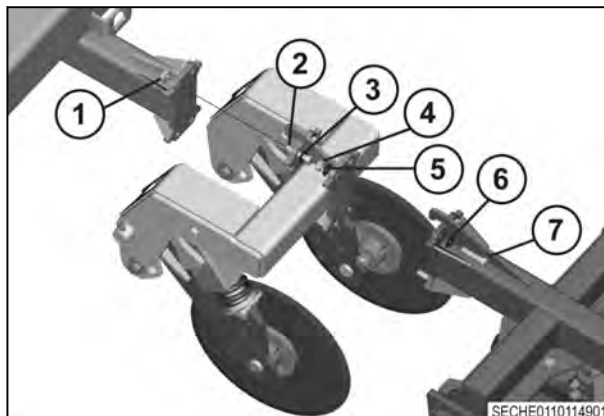

Fig. 368

### 7.13.2 Assembling the fertilizer bander with the dry tube

Install the fertilizer tube (4) to the bander frame with the two  $1/2 \times 1-3/4$  bolts (1). Install the  $1/2$  lock washers (2), and the  $1/2$  nuts (3).

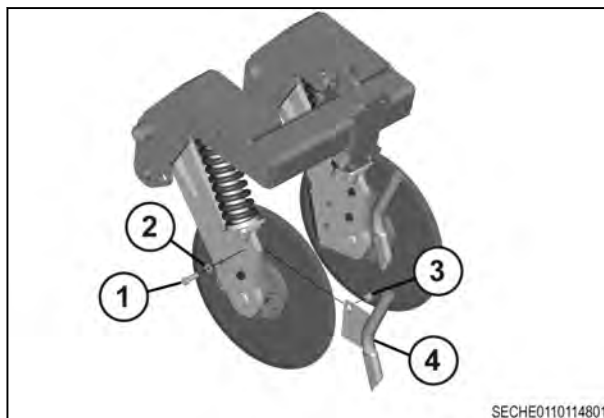

Fig. 369

### 7.13.3 Assembling the fertilizer bander with the NH<sub>3</sub> injector and the dry tube

1. Install the nylon anhydrous injector (8) on the scraper with the two  $1/4 \times 3/4$  carriage bolts (9). Install the two  $1/4$  lock nuts (7).
2. Install the dry tube (5) on the scraper back with the two  $5/16 \times 3/4$  carriage bolts (6). Install the two  $5/16$  lock nuts (4).
3. Install the scraper assembly on the bander frame with the three  $1/2 \times 1-3/4$  bolts (1). Install the  $1/2$  lock washers (2), and the  $1/2$  lock nuts (3).

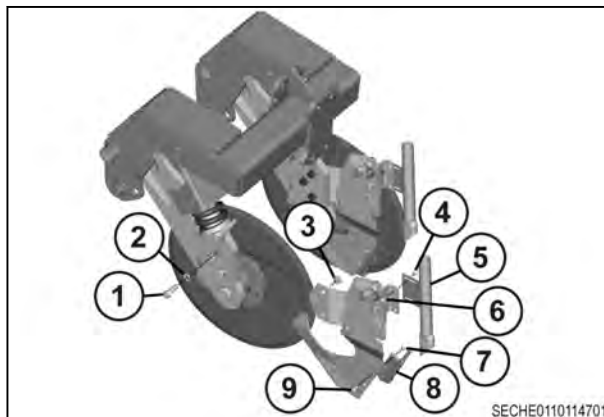

Fig. 370

## 7.14 Installing the soybean toolbar

Install the soybean toolbar to the toolbar frame. Install the four 5/8 x 2-1/2 bolts (4), the eight 5/8 washers (3) (2), and the four 5/8 nuts (1).

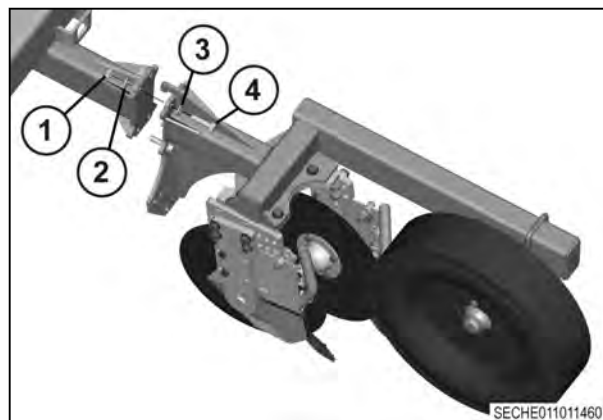

Fig. 371

## 7.15 Installing safety and information signs

### 7.15.1 Installing safety signs

#### Procedure

1. Wipe the area that the sign will be installed with denatured alcohol before installing the sign.
2. Install safety signs. See the information about the safety sign locations.

### 7.15.2 Installing information signs

#### Procedure

1. Wipe the area that the sign will be installed with denatured alcohol prior to installing the sign.
2. Install the restrictor signs (1) on the rod end (2) of all of the wing lift cylinders.

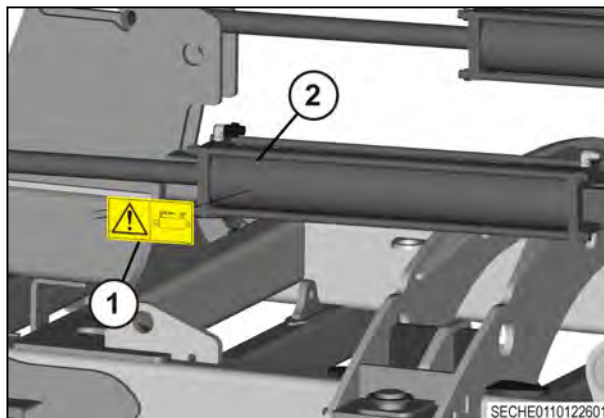

Fig. 372

3. Install the patent signs (1) on the left-hand and right-hand side of the main frame.

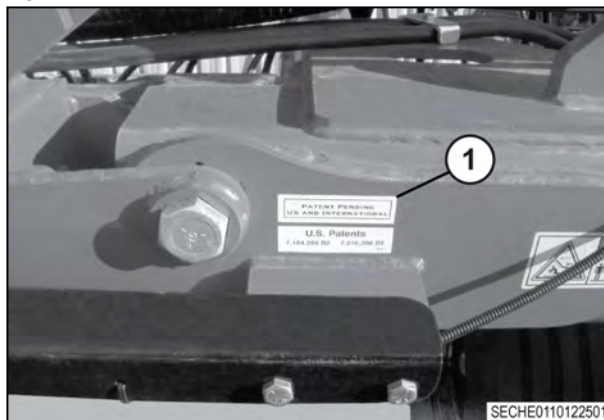

Fig. 373

4. Install the branding signs (1) on the outside of the drawpoles.

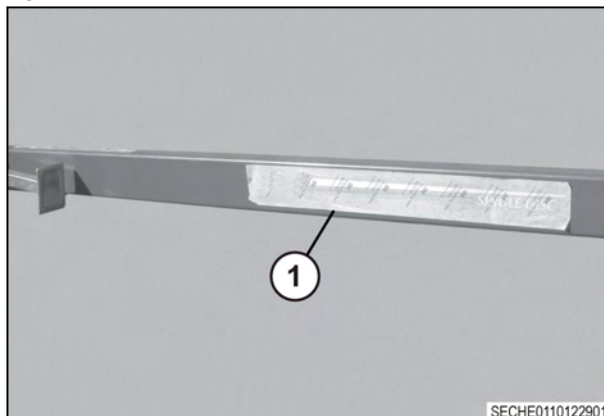

Fig. 374

5. Install the depth stop sign (1) on the front of the main frame.

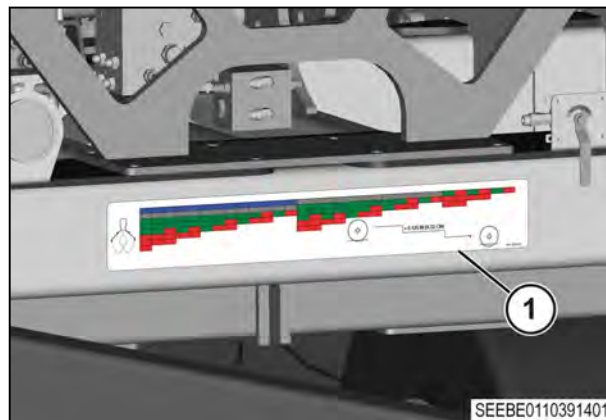

Fig. 375

6. Install the toolbar lock sign (2) under the right-hand lockout valve. Install the hydraulic lift assist sign (1) under the right-hand lockout valve if your machine is equipped with the hydraulic lift assist.

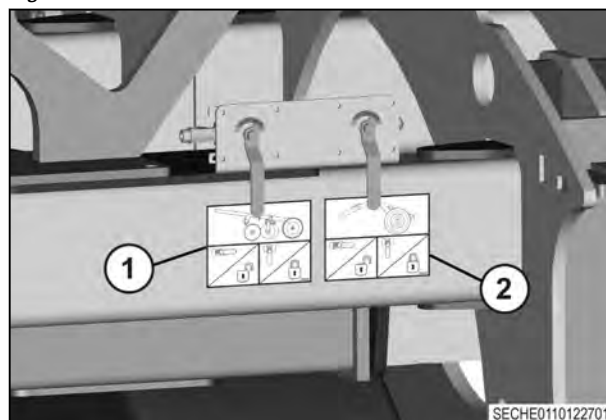

Fig. 376





# Index

## A

Actual rpm of flow-meter .....	77
agricultural chemicals .....	12
Air pressure .....	
Frame and rear hitch tire .....	100
Packing tire .....	59
Anhydrous ammonia .....	68
Application rate .....	
Actual .....	71
Target .....	70
Applied area counter .....	74
Applied weight counter .....	74
Assembly .....	
2 Zone .....	218
4 Zone .....	221
Blockage Sensors .....	213
Bulkhead .....	162, 196
Down Pressure Harness .....	166, 202
Down Pressure Hydraulics .....	151, 175
Dry Tube .....	228
Dual Hitch Mounted Flow Dividers .....	211
Fertilizer Bander .....	228
Floating Rear Hitch .. 151, 157, 160–162, 165–167, 174	
Frame height control .....	141
Hydraulic Caster Lock .....	199
Hydraulic Lift Assist .... 175, 183, 188, 189, 192, 196, 198, 200, 202, 208	
Hydraulics .....	141
Information Signs .....	230
ISO Harness .....	174, 208
Lift Wheel .....	120, 122
Main Frame .....	108, 120, 160, 188
Marker Lamp Harness .....	202
Marker Lamps .....	167, 202
NH3 .....	228
One hub lift wheel .....	113
Outer Toolbars .....	127
Preparing for .....	107
Pull Hitch .....	137
Rear Axle .....	189
Rear Hitch .....	165, 198
Rear Hitch Wheel .....	161
Rolling Mount Flow Divider .....	165, 200
Safety Signs .....	230
Seed Delivery .....	224
Seed Tower .....	218, 221
Seed Tower Manifold .....	217
Soybean Toolbar .....	229
Toolbar .....	124, 127
Toolbars .....	133
two hub lift wheel .....	115
Wing .....	108, 109
Wing Extensions .....	109, 122
Wing Frame .....	122
Wing Lift Hydraulics .....	157, 183
Wireless Blockage Monitor .....	212
Wireless Blockage Monitor Harness .....	215

Work Switch Sensor .....	149
--------------------------	-----

## C

Cam block .....	103
Components .....	45
Connecting the drill .....	50
Connector .....	
ISOBUS .....	49
Control valve gain .....	78
Counter .....	
Applied area .....	74
Applied weight .....	74

## D

Disconnecting the drill .....	52
disposal of waste .....	41
Down pressure control box .....	63

## F

Fertilizer bander attachment .....	
Adjusting depth .....	103
fire prevention and first aid .....	15
Five-section frame .....	44
Frame height cylinders .....	
Phasing .....	90
Putting in phase .....	90

## G

Grease fitting locations .....	82
Ground speed .....	71

## H

high pressure leaks .....	16
Hydraulic caster lock .....	63
Hydraulic lift assist .....	63, 66
Hydraulic lift assist caster wheel .....	
Hydraulic lock .....	66
Lock pins .....	23
Locking .....	23
Unlocking .....	24
Hydraulic lift assist lock-out valve .....	25
Hydraulic system .....	
Bleeding air .....	91

## I

informational messages .....	9
intended use .....	41
Introduction .....	41
ISOBUS connector .....	49

<b>L</b>		Secondary flow dividers .....	210
Leveling wing frame .....	86	Seed depth .....	
Liquid calibration number .....		Adjusting .....	62
Calculating .....	74	Checking .....	60
Verifying .....	75	Collar sequences .....	61
Lock .....		Initial collar sequences .....	62
Hydraulic lift assist caster .....	23	Seed depth collar .....	60
Hydraulic lift assist hydraulic caster lock .....	66	Seeding .....	
Toolbar .....	20	Preparing the drill .....	57
Wing .....	18	Seeding indicator .....	72
Lubrication and maintenance chart .....	81	Serial number .....	
		Location .....	42
		serial number description .....	42
<b>M</b>		Settings screen .....	76
machine identification .....	42	Single disc drill .....	44
Machine width .....	77	Specifications .....	97
Major components .....	45	Storage .....	
Marker lamps .....	26	Preparing the drill .....	92
Maximum Speed .....	99	Removing the drill .....	92
Menu buttons .....	68		
		<b>T</b>	
<b>N</b>		Tank .....	
NH3 system .....		Fill percentage .....	72
Menu buttons .....	68	Size .....	73
Settings screen .....	76	Target rpm of flow-meter .....	77
Work screen .....	69	Three-section frame .....	44
Number of valves .....	78	Tire air pressure .....	
		Frame and rear hitch .....	100
<b>O</b>		Packing .....	59
On/off indicator .....	70	tire safety .....	16
Opening disc scraper .....		Toolbar .....	
Adjusting .....	87	Locking .....	20
		Position icon .....	72
<b>P</b>		Unlocking .....	21
Packing tire .....	59	Toolbar down pressure .....	63, 64
personal protective equipment .....	12	Toolbar lock-out valve .....	25
prepare for operation .....	12	Transport .....	
Preparing the drill .....		Maximum speed .....	99
For seeding .....	57	Preparing the drill .....	55
For storage .....	92	travel on public roads .....	13
For transport .....	55	Turning .....	65
Pressure gauge .....	66		
Product .....		<b>V</b>	
Density .....	73	Valve polarity .....	78
Weight .....	73		
Product on/off indicator .....	70	<b>W</b>	
proper disposal of waste .....	41	Wing frame .....	
Purging air from the system .....	75	Leveling .....	86
		Wing lock .....	
<b>R</b>		Installing .....	18
replacement parts .....	17	Removing .....	19
		word to the operator .....	10
		Work screen .....	69
<b>S</b>			
safety alert symbol .....	9		
safety messages .....	9		
safety signs .....	9		
Safety signs .....			
Location .....	27		



