

Amity

TECHNOLOGY



OWNERS OPERATING & PARTS MANUAL



2800 & 3350

2010 AIR SYSTEM

Amity Technology, LLC
2800 7th Avenue North
Fargo, ND 58102
(701) 232-4199
www.amitytech.com

AMITY TECHNOLOGY, LLC LIMITED WARRANTY FOR NEW PRODUCTS

1. **General Provisions.** This Warranty shall apply to the original purchaser of (1) any new and unused machine manufactured by Amity Technology, LLC ("Amity"), and (2) any new and unused part which is manufactured by Amity for use in an Amity machine, jointly referred to as "Products," whether such Product is purchased through a dealer or directly from Amity. Under this Warranty, Amity will repair or replace, as it chooses in its sole discretion, any covered Product, or any component thereof, which Amity determines to be defective. This Warranty shall be in effect for a period of twelve (12) months ("the Warranty Period"), beginning on the date of delivery of the covered machine or part by the dealer or Amity to the purchaser ("the Warranty Start Date"). The purchaser must pay the cost of transportation of a Product to be repaired or replaced to and from an authorized Amity dealer. This Warranty may not be transferred from the original purchaser of a Product to any other person. This Warranty does not give a purchaser the right to any relief other than repair or replacement of the Product, and it specifically does not allow for consequential or incidental damages, exemplary or punitive damages, or costs and fees.
2. **Scope and Limitations of Warranty.** With respect to machines, this Warranty is void if any part not supplied by Amity is used in assembly or repair of the machine, or if the machine has been altered, abused or neglected, as determined by Amity. With respect to parts, this Warranty is void if the part is used in any manner other than that for which it is intended. This Warranty does not extend in any way to tires and any other component of a Product warranted by another manufacturer, a copy of which warranty is provided herewith ("Third-Party Warranties"). In the event Amity determines that a Product is not defective, or that any other provision of this Paragraph 2 operates to limit the Warranty, this Warranty shall not apply and the purchaser shall be responsible for transporting the Product from the authorized Amity dealer's location within 10 days of notice by Amity.
3. **Procedures for Obtaining Service.** To secure Warranty service, a purchaser must (1) report the defect to an authorized dealer and request repair within 45 days of the failure and within the Warranty Period; (2) present evidence that this Warranty applies to the Product; (3) present evidence of the Warranty Start Date; and (4) bring the Product to an authorized Amity dealer within a reasonable period of time after reporting the defect.
4. **LIMITATION OF IMPLIED WARRANTIES AND OTHER REMEDIES.** To the extent allowed by law, neither Amity, its dealers, nor any company affiliated with Amity makes any warranties, representations, or promises as to the quality, performance, or freedom from defect of any Product covered by this Warranty.
AMITY HEREBY WAIVES, TO THE EXTENT APPLICABLE, ANY AND ALL IMPLIED WARRANTIES OF MERCHANTABILITY AND FITNESS FOR A PARTICULAR PURPOSE. A PURCHASER'S ONLY REMEDIES IN CONNECTION WITH THIS WARRANTY ARE THOSE SET FORTH ON THIS PAGE. IN NO EVENT WILL AMITY, ITS DEALERS, OR ANY COMPANY AFFILIATED WITH AMITY BE LIABLE FOR INCIDENTAL, CONSEQUENTIAL OR PUNITIVE DAMAGES.
Some states do not allow waivers of certain warranties, so the above waivers may not apply to you. You may also have other rights which vary from state to state.
5. **No Dealer Warranty.** This is the exclusive warranty applicable to Amity Products. No dealer has any authority to make any other warranty, modify, limit, or expand the terms of this Warranty in any fashion, or make any representation or promise on behalf of Amity.
6. **Dispute Resolution.** Any controversy or claim arising out of or relating to this Warranty must be settled by arbitration in Fargo, North Dakota, at a time and location designated by the arbitrator, but not exceeding 30 days after a demand for arbitration has been made, and may be conducted by electronic, video, or other technical means. Arbitration will be conducted by the American Arbitration Association in accordance with its Rules of Commercial Arbitration, and judgment upon the award rendered by the arbitrator may be entered in any court having jurisdiction thereof. The arbitrator will have the authority to order Amity to undertake a repair or replace any Product, at its election, if the arbitrator finds that this Warranty requires Amity to do so. The arbitrator will not have the authority to impose any other remedy against Amity, including without limitation consequential or incidental damages, exemplary or punitive damages, or costs and fees.

• AMITY TECHNOLOGY, LLC • 2800 7TH AVENUE NORTH • FARGO, ND 58102 • e-mail address: info@amitytech.com •

(701) 232-4199 fax (701) 234-1716

Prices subject to change without notice

TABLE OF CONTENTS

Table of Contents	4
Congratulations!.....	6
Precautions	6
Features and Specifications.....	7
Air Cart	
Conversion Factors	
Formulas	
Mechanical Systems - Setup and Operation.....	8
Safety Railing / Ladder	
Product Bin Lids	
Auger	
Ground Drive	
Hydraulic Systems	
Variable Rate Drive	
Blower	
Tires and Rims	
D3 System Overview	15
D3 System Hardware	
D3 User Interface	
Product Bins and Meters - Setup and Operation.....	21
Setting Bin Fill Parameters	
Adjusting Product Meters	
Ground Drive Calibration and Operation	
Variable Rate Drive Calibration and Operation	
ART System - Setup and Operation.....	36
Setting Sensor Sensitivity	
Setting the Alarm On Feature	
Using ART Loop Status Pages	
NH3 System - Setup and Operation	39
Calculating Liquid Calibration Number	
Calibrating the NH3 Controller	
Checking and Fine-Tuning NH3 Calibration	
Calibrating the NH3 Tank Fill Indication	
Purging the NH3 System	
Setting the NH3 Gain Value	
Setting NH3 Work Mode (Manual/Auto)	
Testing NH3 System Components	
Mechanical Systems - Maintenance and Troubleshooting.....	44
Routine Maintenance	
Changing Metering Rolls - Ground Drive System	
Changing Metering Rolls - Variable Rate System	
Flute Options	
Other Meter Adjustments	
Gear Box	
Mechanical System Troubleshooting: Common Problems and Solutions	
Storage	

D3 ISO Monitor - Other Settings.....	51
Initial System Startup Parameters	
Overview of the Calibration Page	
Setting Speed Calibration	
Setting Implement Width	
Resetting Field and Total Acres	
Setting the Number of Fan Targets	
Setting Fan High and Low Speed Alarms	
Shaft Settings	
Setting the Speed Input Type	
Setting the Type of VT (Task Controller)	
Setting the VR Index	
Turning On (Assigning) and Turning Off Sensors	
Setting Sensor Logic	
Sensor Assignment and Diagnostic Reference Channel Map	
Setting Up Automatic and Manual Master Work Switch Operation	
Storing User Calibration Values and Settings	
Restoring User Calibration Values and settings	
Restoring Default Calibration Values and Settings	
D3 ISO Monitor - Diagnostics and Troubleshooting	61
Sensor Diagnostics	
Turning Sensors On and Off	
Using Test Speed to Simulate Forward Motion	
Sensor Troubleshooting: Common Problems and Solutions	
ART System - Diagnostics and Troubleshooting	65
ART Troubleshooting: Common Problems and Solutions	
D3030 VT - Installation and Operation.....	68
Installing the D3030 ISO VT	
Operating the D3030 VT	

CONGRATULATIONS!

Congratulations on your purchase of an Amity Technology Air Cart! Your Model 2800 or 3350 Air Cart has been designed to be durable, versatile, and simple to use.

Your Air Cart features stainless steel tanks and metering components, a streamlined and reliable meter system, a fill/unload auger with cupped poly lighting, and a world class ISBOBUS-compatible monitoring and control system.

The following pages contain a wealth of important information on your Air Cart's features, equipment and systems. Read this manual carefully to learn how to set up, operate and use this equipment.

PRECAUTIONS

Safety First

The purpose of this manual is to assist you in safely operating and maintaining your Amity Technology equipment. It is the responsibility of the owner to ensure that anyone operating this equipment thoroughly reads and understands the information in this document.

It is not possible to overstate the importance of safety. Serious injury or death can result from improper operation of any farm equipment. We have taken great care to point out potential hazards that require special consideration.

Warning and Caution Symbols



This manual uses the following symbols to signify caution and warning. For your own safety take note of these symbols and exercise caution when working with this equipment.



Warnings

***ALWAYS** know your equipment. Read the owners manual before operating.*

***DO NOT** allow anyone to ride on the air system.*

***ALWAYS** install and transport stops when transporting the drill.*

***ALWAYS** use an adequate tow vehicle.*



***ALWAYS** remember to properly secure the safety chain.*

***DO NOT** Transport at speed greater than 20 MPH (32 KmPH).*

***DO NOT** modify or alter this equipment without first contacting Amity Technology, LLC.*

Caution

***ALWAYS** keep decals free of dirt and replace if they become damaged. See the parts section for proper placement.*



***ALWAYS** avoid high-pressure fluids. Use a piece of cardboard to search for suspected hydraulic leaks.*

FEATURES AND SPECIFICATIONS

Air Cart

Feature	AS2800	AS3350
Hopper Capacity	280 Bu (168 rear, 112 front)	335 bu (200 rear, 135 front)
Blower Drive	Hydraulic	Hydraulic
Meter Drive	Ground (optional Hydraulic)	Ground (optional Hydraulic)
Wheel Spacing	120" (36.6 m) front 150" (45.7 m) rear (120" rear optional)	120" (36.6 m) front 150" (45.7 m) rear (120" rear optional)
Tire Size	23.1 x 26 R1 - Standard (58.7 cm x 60 cm) 18.4 x 26 - Optional (46.7 cm x 60 cm)	23.1 x 26 R1 - Standard (58.7 cm x 60 cm) 18.4 x 26 - Optional (46.7 cm x 60 cm)
Fill/Unload Auger Cupped steel flighting (poly flighting optional)	8" x 18' (20.3 cm x 5.49 m)	10" x 21' (25.4 cm x 6.40 m)
Total height	12' 7" (3.84 m)	13' 5" (4.09 m)
Total length	27' (8.23 m)	27' (8.23 m)
Max width	14' 5" (4.39 m)	14' 5" (4.39 m)
Fill height	11' (3.35 m)	11' 10" (3.60 m)
Minimum ground clearance	19" (48.3 cm)	19" (48.3 cm)
Empty weight	8400 lbs (3810 kg)	8600 lbs (3900 kg)

Conversion Factors

1 Hectare = 2.47 Acres	1 lb = 0.45359 kg	1 bushel = 1.2445 cubic ft
1 acre = 43,560 square feet	1 lb = 16 oz	1 bushel = 0.0352 cubic meters
1 acre = .404 Hectares	1 kg = 35.3 oz	1 bushel = 9.31 gallons
1 inch = 2.54 cm	1 oz = 0.028 kg	1 PSI = 6.8948 kPa
1 foot = 0.3048 m	1 mph = 1.609 kph	1 GPM = 3.785 LPM
	1 mile = 1.609347 km	

Formulas

$$\text{Rate (lbs/min)} = \frac{\text{Width (ft)} * \text{Speed (mph)} * \text{Field Rate (lbs/acre)}}{495}$$

$$\text{Performance (acres/hr)} = \frac{\text{Width (ft)} * \text{Speed (mph)}}{8.25}$$

MECHANICAL SYSTEMS - SETUP AND OPERATION

Safety Railing / Ladder

Your Air Cart is equipped with a ladder and safety railings for access to the top of the tanks. Always make sure that the safety railings are secured in the raised position when operating the air system. The railings may be lowered for storage if required.

To lower the railings, remove the top bolt from each of the legs on the railing sections. Rotate the railing section down so that they hang beside the air system and reinsert the bolts in the holes for storage.



Caution

Do not lower the railings while standing on the catwalks. Use a suitable ladder and lower them from below. Always have the railings raised when working on top of the air system.



Safety railings

Product Bin Lids

The compartment lids on the air system compartments must be properly closed and sealed for the meters to deliver product properly.

Periodically check the lid for proper adjustment and inspect the seal for damage.

To determine whether the lid is adjusted properly, observe the lid when it is unlatched. It should incline slightly toward the latch end. A firm pull on the latch handle should be required to over-center the latch.

To adjust the hinge end of the lid, loosen or tighten the jam nuts on the hold down bar. (See photo)

To adjust the latch, loosen or tighten the nuts on the toggle u-bolt. (See photo)

In the off season, it is recommended that the latch be released to relieve pressure on the gasket.



Lid and latch with toggle u-bolt adjustment



Jam nuts on hold-down bar

Caution



If equipped with screen baskets, do not step or lean on the screens. They will not support a person's weight and may fall into the tank, resulting in injury.

Auger

Your Air Cart is equipped with an auger for loading and unloading the product bins. The auger is mounted on a swing arm that allows a flexible discharge hose to be moved to each compartment without moving the hopper. The swing arm also enables the auger to be turned around to unload and clean out the compartments.

The auger's hydraulic drive is supplied with oil from the blower hydraulics. A diverter valve above the blower directs oil to the auger. This may be switched with the blower running.

The auger also has a three position variable speed valve mounted on it to run the auger forward, backward or to stop.



Air cart with auger

Using the Auger to Load Products

The auger can be used to load and unload seed tanks. It can be adjusted on brackets to suit the operator's needs.

To place the auger in operating position:

1. Drop the front bracket lock pin just far enough to release the small pivot arm. (Unpin the long arm only to unload.)
2. Loosen the lock assembly. (Tee Handle)
3. Remove the auger from the rear clamp assembly.
4. Swing the hopper end of the auger away from the Air System and allow the short pivot arm to come out, away from the machine.
5. Place the hopper on the ground in a position perpendicular to the center line of the tanks with the discharge end of the auger between the compartment lids. From this position the discharge end of the auger should be able to be moved between compartments without moving the hopper.



Swing arm, bracket lock pin and small pivot arm



Air cart with auger in loading position

Using the Auger to Unload Products

1. Swing the large arm far enough away from the machine to allow the hopper to fit between the wheels.
2. Place the hopper under the meter for the compartment you wish to empty.



Placing the hopper under the meter

3. Close the metering slide.
4. Remove the product meter door.
5. Open the metering slide to control flow from the compartment.

Note

Removing the pointer allows the gate to be opened without changing the rate setting.



The meter with door removed

Cleaning Out the Auger

1. Tip the hopper upside down to empty.
2. Run the auger backwards until the auger tube is empty.



Hopper in the upright position

Ground Drive

On air carts equipped with ground drives a magnetic clutch allows the drive to be disengaged. The magnetic clutch uses electrical power to hold it engaged. The clutch is turned on and off by the D3 System either automatically when the drill is raised and lowered, or manually by pressing a manual Master Work Switch soft key on the virtual terminal in the tractor cab. The clutch requires no service.

When transporting long distances, remove the drive chain at the drive wheel. This will extend chain and sprocket life.

Note

Maximum recommended transport speed is 20 mph



Magnetic clutch

Hydraulic Systems

The hydraulic system on 2800/3350 air systems consists of a blower control circuit, an auger control circuit, and an optional VR drive control circuit. A combination of various control valves enables all three circuits to be powered by one hydraulic remote on the tractor. This system was designed to function under a maximum hydraulic pressure of 2900 psi.

Hydraulic Capacity

To run the hydraulic blower at the appropriate blower rpm., the tractor must have the following hydraulic capacities:

Blower RPM	Hydraulic Requirements (Ground Drive)	Hydraulic Requirements (Variable Rate)
5000	13 GPM at 1500 to 2200 PSI	18 GPM at 1500 to 2200 PSI
6000	16 GPM at 1700 to 2450 PSI	21 GPM at 1700 to 2450 PSI

Air System to Drill Hydraulic Couplers

The couplers connecting the air system to the drill/implement are 3/4 inch, high-flow couplers. Using 3/4 inch couplers reduces the pressure drop across the coupler and enables the operator to easily disconnect the air system from the drill.

The blower motor case drain line employs a 1/2 inch coupler. This smaller size ensures that it cannot be confused with the larger 3/4 inch couplers.

It is important to ensure that the pressure line on the tank is connected to the pressure line on the drill.



Hydraulic Couplers

Tractor to Blower Hydraulic Couplers

One-half (1/2) inch Pioneer tip couplers connect the blower pressure and return lines to the tractor.

A 3/8 inch flat-face coupler tip on the drill connects the case drain line to the tractor. This line must be connected or the blower motor will be damaged. If a case drain return port is not available on your tractor, contact your dealer for assistance in determining how to connect this line to the tractor's hydraulic reservoir.

A 3/4 inch low-pressure return tip is included with all Amity implements. It is also available through Amity Service Parts. If your tractor has a low-pressure port available, this tip can be used on the 3/4 inch blower return line to eliminate the pressure drop caused by the 1/2 inch Pioneer tip and the tractor's hydraulic valve on the return side. This tip can also be used on the case drain line, if the 3/8 inch flat face port is not available and the 3/4 inch low pressure return port is.

Do not install a tee connecting the blower return line and the blower case lines together. The blower case line must always be connected to a direct return to the hydraulic reservoir or blower motor failure will result.

The hydraulic line marked *Pressure* must be used to operate the blower. A check valve is installed in the blower circuit to protect the motor from an accidental pressurization of the return line.

Note

The 3/4 inch low pressure return tip is not compatible with the 3/4 inch high flow fittings used at the front of the cart. They look similar, but they are not compatible.



Tractor Hydraulic Connections (1)



Tractor Hydraulic Connections (2)

Variable Rate Drive

Air systems equipped with the variable rate option use electric-over-hydraulic (EOH) technology to control the meter speed independently of ground speed. This gives the operator the benefit of a faster calibration procedure and on-the-go rate changing capability as well as the potential to apply product to a prescription map using GPS.

The variable rate control valve diverts 5 GPM of hydraulic fluid flow from the fan circuit to power the variable rate drive motors. An electro-proportional flow-control valve controls the speed of each motor, allowing the meters to turn at speeds completely independent of each other.



Variable Rate Control Valve

The variable rate drive motors mount to the meter housing and provide a direct drive of the meter shaft. The motor has a built-in speed sensor to provide accurate meter speed feedback to the electronics system.



Variable Rate Meter Drive Motor

Blower

The air cart's blower system generates air pressure/flow to carry the seed or other input products through the system to the implement. The blower is driven by a hydraulic motor.

Two $\frac{3}{4}$ " hydraulic lines supply oil to the blower. A check valve is used on the return line to protect the system from running backwards. The hydraulic motor on the blower also has an internal check valve to prevent motor cavitation during shut down.

A third smaller (1/2") line connected to the blower motor is a case drain line. It is imperative that this is connected to a line directly to the tractor reservoir. Back pressure on this line will cause the shaft seal on the motor to fail. It is recommended that a female connector is used on this line at the tractor connection so that this line cannot accidentally be connected to pressure.

The only serviceable part on the blower is the shaft seal. This may be replaced if the motor leaks at the shaft. Do not disassemble the motor to replace the shaft seal. It is secured by a snap ring and can be removed with a seal pick.

A diverter valve above the blower selects either the fan or auxiliary (auger and/or winch) function. Push the knob in to run the blower. Pull the knob out to run the auger or winch.



The blower and associated hydraulics



Caution

Be sure that the case drain line on the blower motor is not connected to pressure. Damage to the shaft seal or motor will result.



Warning

Do not under any circumstances disassemble the motor. It is very difficult to assemble correctly and motor destruction will result from running an incorrectly assembled motor.

Setting Blower Speed

The blower should be operated at as slow a speed as possible to prevent damage to seed. If operated too slowly, line blockage will occur. Typical blower speeds are between 3800 and 6000 RPM. Drill width, product, rate, humidity and other factors affect blower speed.

One method to determine blower RPM is to remove a final run from the seed boot or shoe. Hold the hose about 5 feet off of the ground pointing straight up. Turn product out of the meter with the blower running. The product coming from the hose should blow out of the hose about 8 inches into the air. Adjust blower RPM accordingly.

If you do not have a run blockage monitor, carefully watch to see that all runs are operating after changing blower speeds. To check runs, turn meter(s) with blower running and look to see that there is product at each ground opener.



Note

The number of outlets on the drill will directly affect the blower rpm. The more outlets in use, the higher the pressure required to maintain blower rpm. See your dealer for hydraulic adjustments to your tractor, if necessary.

Note

A diverter valve (2) above the blower selects fan or auxiliary (auger and/or winch) function. Push the knob in to run the blower. Pull the knob out to run the auger or winch.



Warning

Do not under any circumstances disassemble the motor. It is very difficult to assemble correctly and motor destruction will result from running an incorrectly assembled motor.

Tires and Rims

Inflate tires to the pressure indicated in the adjacent table. Torque lug nuts to 140 ft/lbs and retighten after the first 10 hours of operation.



CAUTION!



TIRE PRESSURES

Tire Size	Tire Ply	Tire Pressure
18.4 X 26.0	10	26 (MAX)
23.1 X 26.0	8	16 (MAX)
23.1 X 26.0	10	20 (MAX)



Caution!

Maximum speed of the air system is 20 mph.

D3 SYSTEM OVERVIEW

Your Air Cart utilizes a state-of-the-art electronic system to monitor and control the air cart's functions. The D3 ISO Monitor system is based on the ISO 11783 standard, often also referred to as ISOBUS. ISOBUS is a communications standard that enables a variety of agricultural electronics systems to talk to each other. Its purpose is to integrate all current and future farm functions by standardizing communication between tractor and implement. ISOBUS permits the use of the same tractor terminal on a number of different machines and hence control of a wide range of implements without the need to reprogram a system.

D3 System Hardware

The D3 ISO System includes a D3 electronic control unit (ECU), which connects to a variety of sensors and an electric-over-hydraulic (EOH) meter drive system. The ECU communicates with a virtual terminal (VT) located inside the tractor cab. The VT displays information and enables you to configure, calibrate and operate multiple systems from a single user interface.

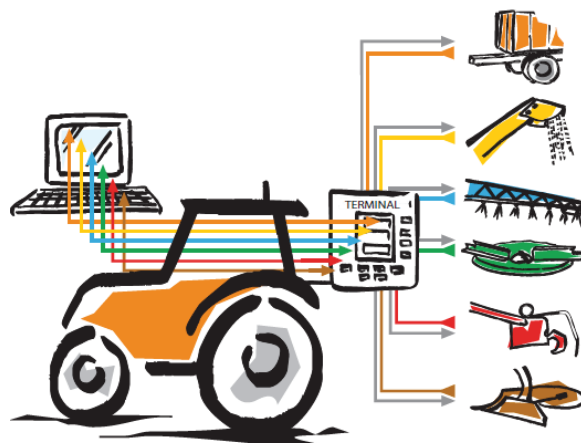

D3 Electronic Control Unit

The ECU is mounted on the air system. It monitors all system sensors and controls the meter drives. The ECU connects to the VT in the tractor cab via an interconnecting cable that plugs into the front of the ECU on one end and into the standard ISOBUS connector on the tractor at the other end.



D3 ECU

Virtual Terminal

The VT in the tractor cab provides a user interface for the system, communicating with the D3 ECU and (any other ISOBUS-compatible equipment you may add to your equipment). Your VT could be the Amity-supplied D3030, the tractor's OEM VT, or any other ISOBUS-compatible VT. (For information on installation and operation of the D3030 VT refer to 68 of this manual.)

Several companies manufacture ISOBUS-compatible virtual terminals. All terminals use the same screen icons to represent the main functions. The control screens, or pages, for the implement (which are displayed in the central area of the screen) are identical for any ISOBUS-compatible terminal.

Currently the following virtual terminals can be used with your ISO Drill Manager system:

- GTA Console 1 and Console 2 (AGCO)
- AFS Pro 600 (Case IH)
- GreenStar2 (John Deere)
- IntelliView II and IntelliView Plus 11 (New Holland)
- IntelliAg (DICKEY-john)
- LH6000 (TeeJet)



D3030 VT



A John Deere VT

Blower Speed Sensor

An inductive sensor on the blower fan provides speed information to the ECU.



Bin Level Sensor

Optical bin sensors indicate when the level of product in the bin has decreased to the level of the sensor. The same sensor detects all types of products. The sensor height can be adjusted vertically to set the alarm point at any desired level.



Meter Box Flow Sensor

A capacitive sensor detects when the meter box is empty. This indicates if the bin is completely empty, or if the product has stopped flowing into the meter box because of bridging or a leaky lid on the bin.



Meter Shaft Speed Sensor (Ground Drive)

A magnetic proximity sensor is used to detect the speed of the meter shaft. This information is used to calculate how much product has been applied and also indicate that the ground drive system is function properly.



Meter Shaft Speed Sensor (Variable Rate)

If the air system was purchased with the variable rate option, an integral speed sensor is provided with the hydraulic motor. This sensor is very accurate and provides the precise meter speed control that is needed.



Ground Speed Sensor

A Hall Effect sensor is used to measure ground speed by counting the teeth on a sprocket located on the rear axle or the clutch shaft.



D3 System User Interface

When the Virtual Terminal in your tractor is powered up it communicates with all ISOBUS compatible devices connected to the ISOBUS communications cable. The VT automatically downloads information about each device connected to the bus. The VT screen displays a page that identifies each connected ISOBUS compatible device.

The VT also downloads "personality data" from each connected ISOBUS device. Personality data includes icons, which are small graphical images representing device functions. Icons, shown on screen in a box called a 'softkey', are typically associated with a pushbutton, membrane or on-screen touch sensitive switch.

D3 System Startup

When you first power up your VT it displays a page with several softkeys available. If your D3 System is connected to the ISOBUS a D3 softkey is included on the screen. (The exact position of the softkey depends on the VT you are using.)



The D3 ISO Softkey

Opening the D3 Startup Page

Selecting the D3 softkey opens the **D3 Startup page**.



Each time the system is powered up basic information about your D3 System is displayed. This information includes:

- System Type (EOH or Ground Drive)
- Number of products (2, 3 or 4)
- Whether your system uses NH3 (0 or 1)

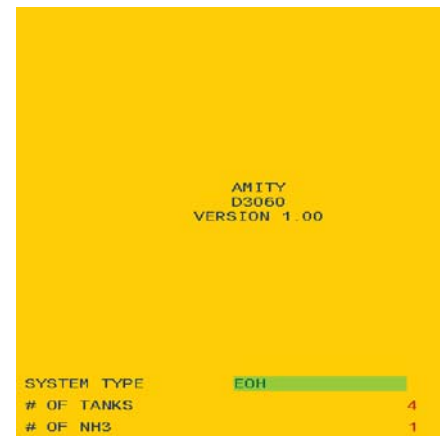

The Amity D3 Startup Page

Opening the D3 Home Page

Selecting the Home soft key (located in the top right corner of the screen) opens the D3 Home page.



The Home (or Main) page is the primary page from which you operate your system. This page displays a summary of the key information you need. (Details later in this manual.)

On color VTs, parameters shown in red can be changed by the operator; parameters in blue are display-only.

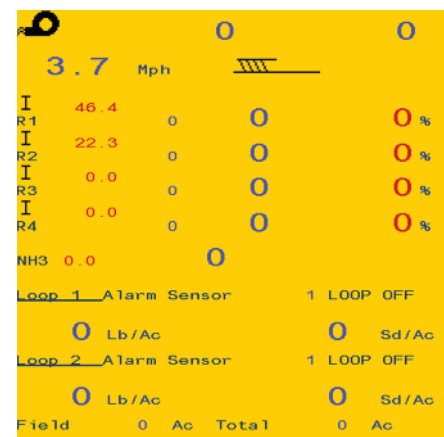

The D3 Home Page

Note

The exact details of how to access and change values and settings may vary from manufacturer to manufacturer. Consult the manufacturer's operating manual for your specific VT to determine the details.

Note

The screenshots used in this manual represent a typical VT. All VTs display the same information in the central part of the screen. The colors, position of softkeys and other details may vary between VT manufacturers.

D3 System Navigation Chart

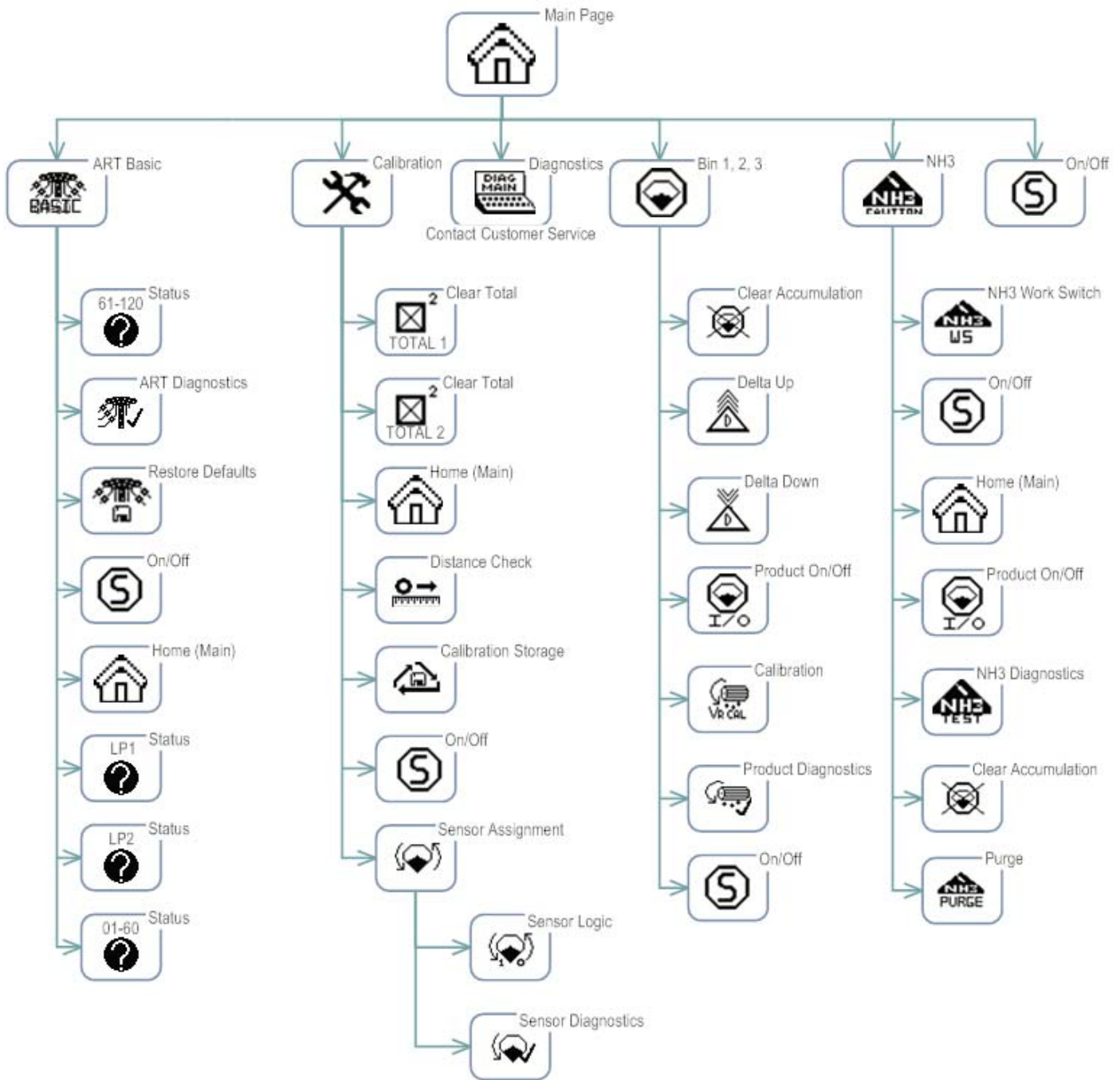





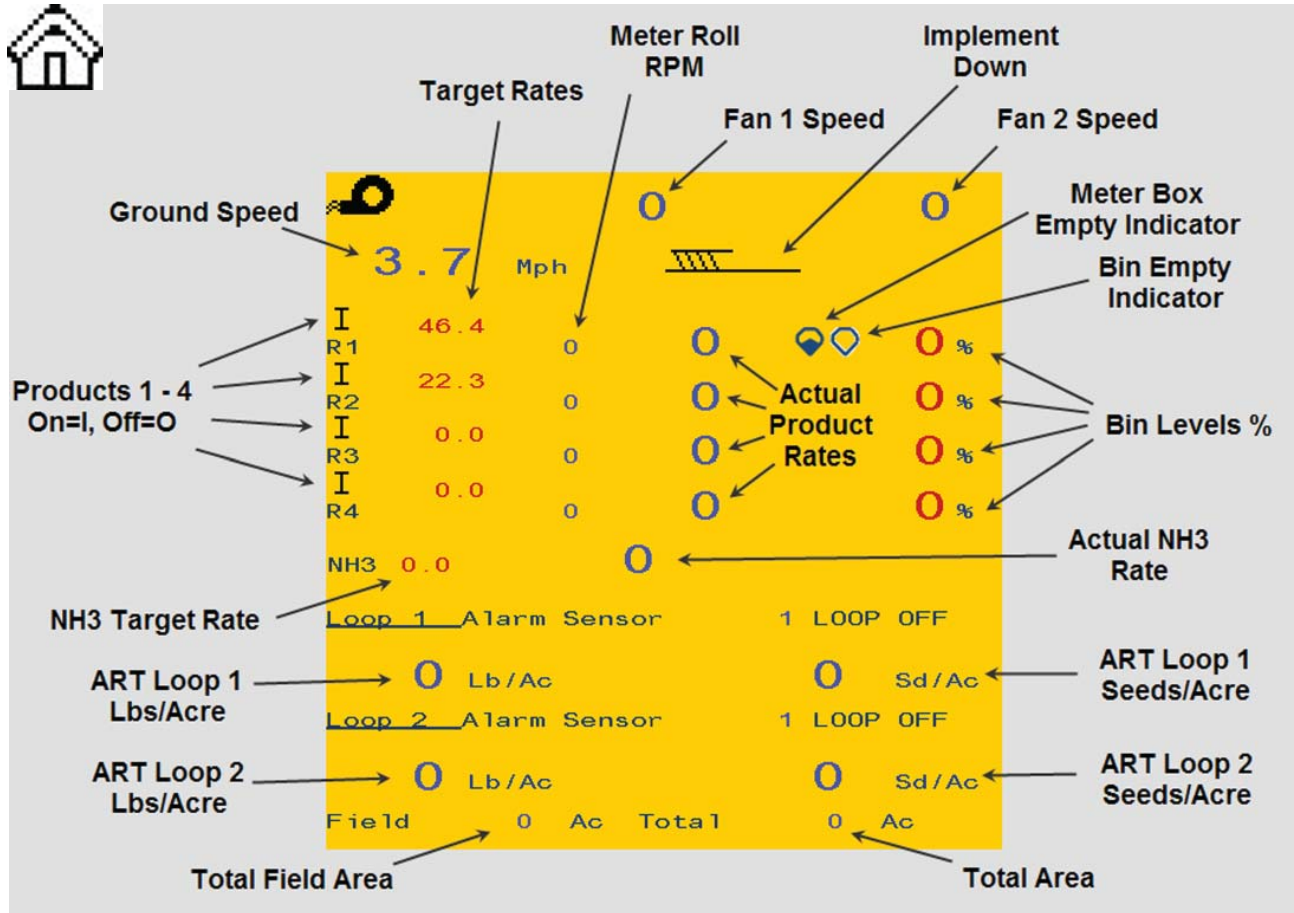

Hint for D3030 Users

If you are using a D3030 VT you can configure the four numbered function keys to switch product meters on and off. For more information on configuring and operating the D3030 virtual terminal, refer to the D3030 VT - Installation and Operation section on 68 of this manual

Overview of the D3 Home Page

The Home (or Main) page is the primary page from which you operate your system. This page displays a summary of the key information you need. Some of this information can be modified as you operate the system, while some is information only. You can also navigate from this page to other pages such as the Product and NH3 pages described in the following sections.



Soft Key Icon	Description
	ART Basic Settings
	Calibration (System Settings)
	Hardware Diagnostics
	Product Bins 1 to 4
	NH3 Cal Settings
	On/Off (Manual Master Work Switch)

Notes

- Target rates can be modified on this page.
- Individual product control is turned on or off on the Product page for each product.

Note

The number of Products shown on the D3 Home page is determined when you enter initial configuration information on the D3 Startup page. (Refer to "The D3 Startup Page" on page 17)

What is a soft key?

A "soft key" is a button or touch screen icon that, when pressed, performs a function assigned to it. To navigate to the desired page, press the soft key associated with the icon representing that page.

Manual and Automatic Master Work Switch Operation

The Master Work Switch is the control mechanism to engage or disengage the meter clutch or variable rate drives. Your system can be set up for automatic or manual Master Work Switch operation. The manual Master Work Switch is a soft key, located on the many of the D3 System pages. (This ensures it is available whenever needed.) The automatic Master Work Switch is a sensor, located on the hitch of the implement, that senses when the implement is in the ground.

When the system is configured for automatic Master Work Switch operation, lifting the machine automatically turns off the meter drives and NH3 system. Lowering the machine automatically turns on the meter drives and NH3 system. The manual Master Work Switch must be ON for the automatic Master Work Switch to work. The manual Master Work Switch can override the automatic Master Work Switch to turn the system off. The manual Master Work Switch cannot override the automatic Master Work Switch to turn the system on.

Manual operation is the default setting for the Master Work Switch. See the appendix for information on configuring the Automatic Master Work Switch.

Note

The Master Work Switch soft key indicates its status by displaying the words ON or OFF on the soft key.



The manual Master Work Switch soft key indicating the manual Master Work Switch is OFF

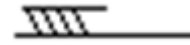

The Implement Down icon appears on the Home page when the implement is down. (This icon also appears when the automatic work switch is disabled.)

Overview of D3 System Alarms

While operating the air cart from the Home page, if an alarm condition occurs, the D3 system sounds an audible alarm and opens the page associated with the alarm. Information about the alarm is displayed. The Acknowledge, Master Work Switch and Home softkeys also appear.

Selecting Acknowledge silences the audible alarm and closes the page (reverting back to the page you were previously on). If the alarm condition persists, after a few seconds the audible alarm sounds again and the alarm page re-appears.

Selecting the Master Work Switch softkey silences the alarm and stops application of product and NH3. You can then investigate the cause of the alarm.

Selecting the Home softkey also silences the alarm, and returns you to the Home page, where you can view additional information about the system.

Possible alarms include:

- ART blockage alarms
- High/Low Fan Speed
- Low Bin Level (Products 1 to 4)
- High/Low Meter RPM
- Meter Box Empty (Product 1 to 4)
- High/Low Application Rate

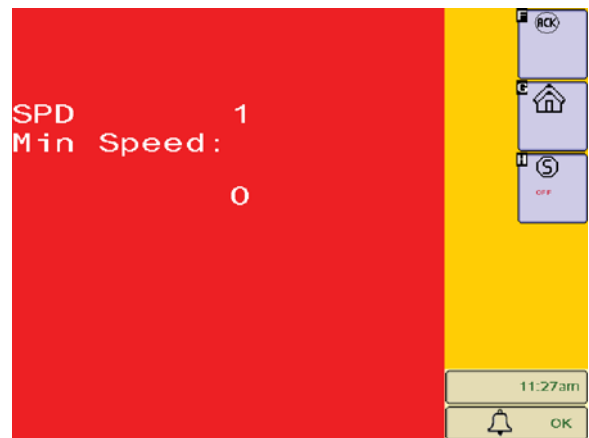

An Alarm page

PRODUCT BINS AND METERS - SETUP AND OPERATION

Each product has its own Product page. Although the Product pages are used during calibration procedures, you must also use the Product pages to turn on and off the product meter. The information displayed at the top of the page (Product On/Off, Target Application Rate, Meter Motor RPM, Actual Product Rate and Bin % Full) is identical to the information shown on the corresponding product line on the Home page.

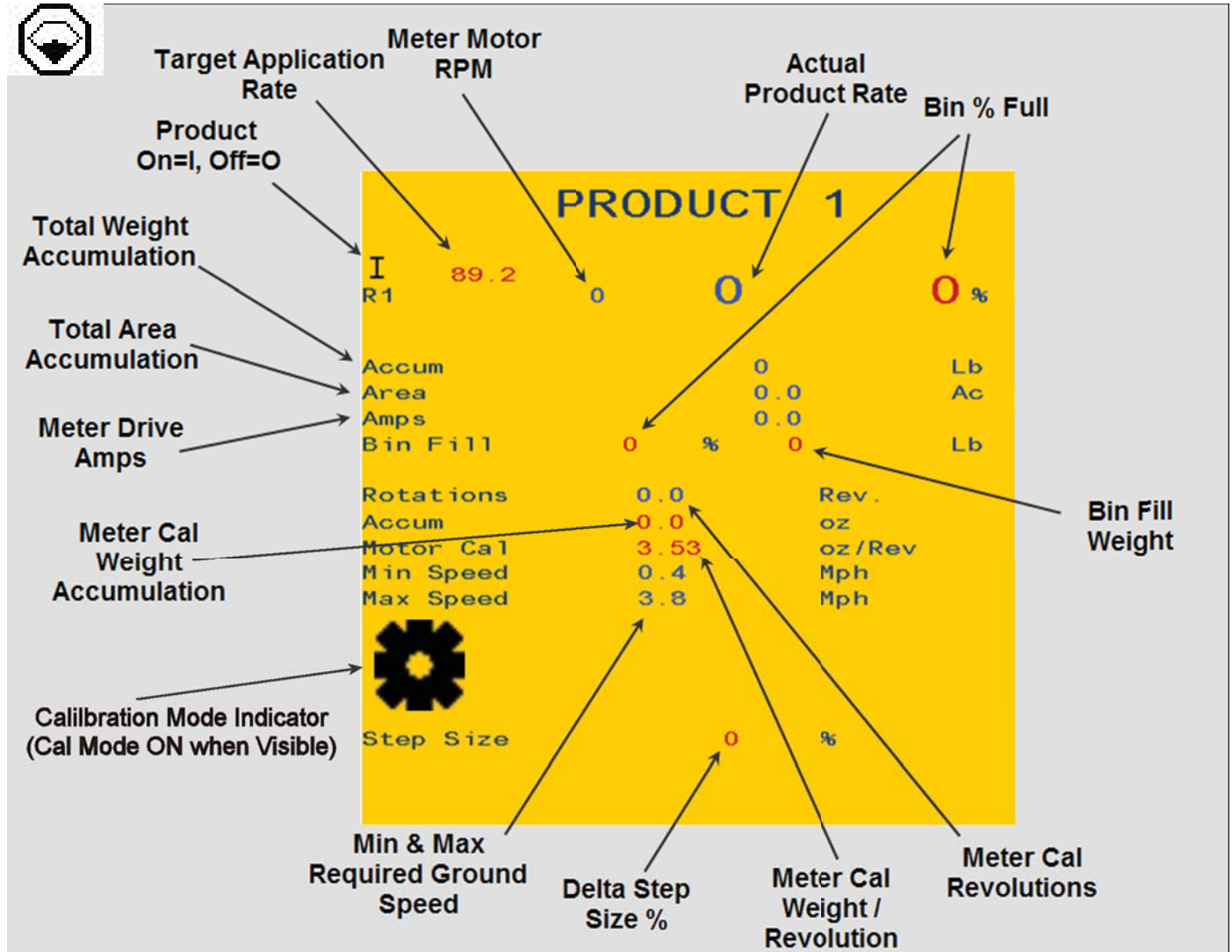

Soft Key Icon	Description
	Home (or Main)
	Clear Accumulation
	Delta Step Up
	Delta Step Down

Soft Key Icon	Description
	Product On/Off
	Calibration Mode (Enable/Disable)
	Product Diagnostics
	Manual Master Work Switch

Notes regarding the Product pages:

- To calibrate product meters (VR only) the product must be enabled (I).
- To apply a product it must be enabled (I) and the Master Work Switch must be On.
- The implement must be moving at 1.5 mph or greater to enable product application.
- For more information on setup and calibration of Product page parameters refer to the appendix.

Setting Bin Fill Parameters

Your ISO monitor provides bin fill indications and low alarms. To calibrate the bin fill measurement you must fill the bin with a known weight of product and enter that value into the Bin Fill, Lb parameter on the Product page. You then estimate the corresponding % full value and enter it into the Bin Fill, % parameter on the Product page.

The following table shows how you can estimate the % full value for Model 2800 and 3350 air systems by correlating the bin level with its height on the tank ladder. The values are the same for the front and rear compartments.

Approximate Tank Fill Percentages

Ladder Rung (from top)	Model 2800	Model 3350
1st	90%	85%
2nd	75%	60%
3rd	45%	35%
4th	15%	15%
5th	5%	5%

To set bin fill parameters:

1. Fill the bin with a known weight of product.
2. Using the table (above) estimate the % bin fill value.
3. On the Home page, press the soft key for the desired bin.
The Product page for the selected bin appears
4. Select **Bin Fill, Lb**.
5. Enter the weight of the product in the bin.
6. Select **Bin Fill, %**
7. Enter the estimated bin fill in %.
8. Press the Home soft key to return to the Home page
9. Repeat the preceding procedure for each product bin.

Note

- Bin Fill lbs has to be set first. You are telling the D3 how much product is in the bin and then telling it what % full the bin is with that much product in it.
- As product is metered out of the product tank, the system continuously recalculates and displays the approximate Bin Fill value, based on the initial Bin Fill value less the product used (calculated from the meter revolutions and the meter calibration).

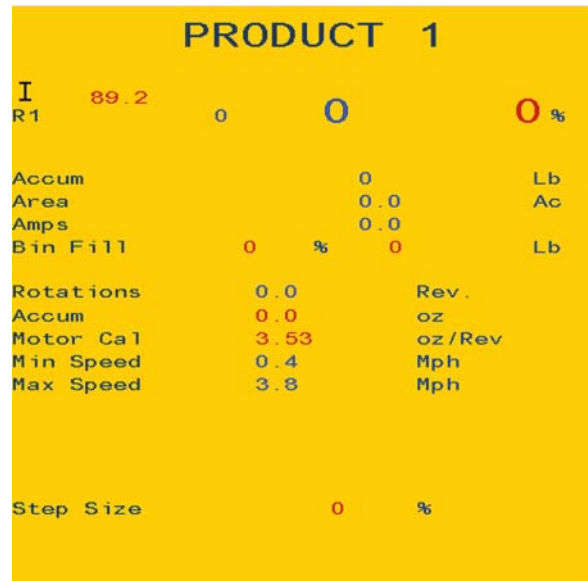

Note

The factory setting for the low bin level sensor causes a low bin level alarm when the bin is 15% full.

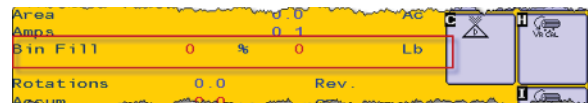

Common Commodity Test Weights

Commodity	Test Weight (lbs/bu)
Wheat	60
Corn	56
Soybeans	60
Fertilizer	60 - 70
Canola	52
Oats	32
Barley	48

Adjusting Product Meters

The product meters deliver seed or fertilizer from the product bins to the air stream via a fluted roller. The amount of the roller that is being used determines the rate at which products are applied.

There are two moveable components in the meter that determine the rate setting.

The primary setting is a flow plate adjusted by a rod connected to a pointer. When a rate setting is selected, the pointer is simply placed at that number on the rate decal. A lock bolt on the pointer rod secures the setting.

The second part of the adjustment is the meter shut off slide. For any rate setting the proper place for shut off slide is against the stop on the pointer. This opens the bottom of the tank compartment the proper amount for the rate setting. A ½" drive ratchet supplied in the toolbox is used to adjust the meter shut off slide.

Any time that a new rate is set, the rate setting should be confirmed by calibrating the meter.

A scale and catch bag are supplied in the tool box for calibration.

Once a rate setting is determined from the rate charts and the meter is set to that setting, perform the following calibration procedures.

When using both tanks for one product, determine the rate for each meter by splitting the desired rate by the ratio of the tanks (60/40). This will result in both tanks emptying at the same time.

Example

If you desire to seed 120 lbs. of wheat using both meters, split the desired **pounds per acre** rate to the ratio of the size of the tanks. i.e. If the Air System is a 60/40 split, set one meter to 72 lbs. (120 x.6) and the other meter to 48 lbs. (120 x.4)

Note

When decreasing the meter setting, it may be necessary to close the shutoff slide and turn the meter to empty it. This will empty the meter and allow the plate to move to a smaller setting.

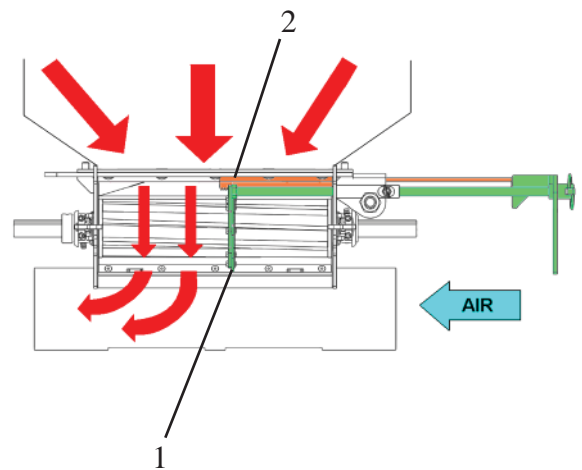
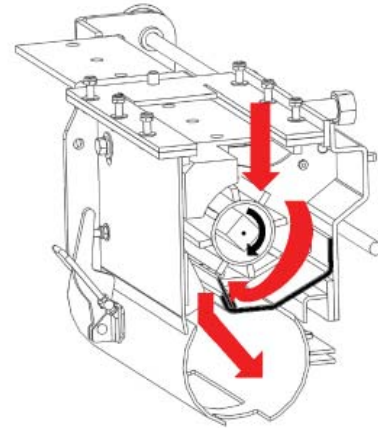

Note

Plate (1) controls how much of meter roller will be used. The shut off slide (2) is opened to the stop on the pointer for any rate setting. When making large rate reductions, close the slide and empty the meter to allow the plate to move to the lower setting. Remember to reopen the slide until it contacts the stop on the pointer.

Ground Drive (GD) Calibration and Operation

If you have a ground drive (GD) system, calibration involves deciding on a fixed target application rate (lbs/acre) and then setting up the meter mechanically to deliver that rate. The ground drive system compensates for speed changes by varying the meter speed to keep application rate uniform. The calibration procedure also includes entering several pieces of information into the D3 System to ensure accurate indications and to avoid nuisance alarms.

Setting up the Application Rate on a GD System

To set up and operate the ground drive:

1. Determine your desired target application rate.
2. Set the pointer on the product meter to your desired target rate setting.
3. Secure the setting by tightening the bolt to lock the pointer rod.
4. Use the ratchet supplied to open the shut off slide until it contacts the stop on the pointer.
5. Hang the calibration bag on the scale and zero the scale so the weight of the bag will not compromise the accuracy of the measurement.
6. Open the clean out door under the air tube by releasing the toggle clamps.
7. Turn the crank at the front of the Air System one complete revolution to prime the meter.
8. Hang the calibration bag on the meter tube so that the clean out door is inside of the bag and the bag is under the openings in the bottom of the air tube.
9. Using the table on the right side of this page, determine the number of turns required to cover 1/10 of an acre.
10. Manually crank the meter the required number of turns.
11. Remove the bag and weigh it on the scale. Multiply the weight times 10 to get the rate per acre.
12. Adjust the meter to a higher or lower setting and repeat the procedure until the desired rate is set.

Note

Look up the rate setting for each tank separately in the appropriate rate chart.

Implement Width (ft)	Turns (of crank) per acre
30	126
32	119
34	112
36	106
38	100
40	95
42	90
44	86
45	85
46	83
48	79
50	76
52	73
54	70
56	68
58	66
60	63

Seed Rate Setting Tips

- *When setting a rate for a small amount per acre such as canola or sunflowers, calibrate with more than 1/10 of an acre amount of turns. Turn out a complete acre for rates less than a 10 lb. rate*
- *Recalibrate rates after seeding a partial tank.*
- *Remember to “prime the meter” by turning the crank before calibrating.*
- *Remember to zero the scale with the empty bag on it before calibrating.*
- *Close meter shut off slide on compartment not being calibrated.*

Note

The data in the above table is based on using either of the following:

- *17 tooth gearbox sprocket with 18.4R26 tires*
- *15 tooth gearbox sprocket with 23.1R26 tires*

Note regarding Target Rate and Motor Cal Settings for Ground Drive Air Systems

With the ground drive system, the application rate is determined by the mechanical settings of the meter. However, the Target Rate and Motor Cal values should still be entered into the system. The D3 System compares the Target Rate value with the Actual Rate value (determined by the Motor Cal value and number of meter revolutions) and initiates an alarm if the Actual Rate varies significantly from the Target Rate setting. The Motor Cal value also is used in calculating the ongoing Bin Fill value and accumulation values

For these reasons the Target Rate and Motor Cal values should be set to ensure that the bin fill indicator and the accumulation totals function accurately.

If you do not wish to use the Bin fill % indication, leave the Target Rate and Motor Cal set to the default values of 60 and 10. These values will ensure that high or low application rate alarms will not sound. Your Bin level and meter box sensors will still function normally to indicate a low bin or empty meter box.

Setting the Target Rate Value for a GD System

1. On the VT, navigate to the Home page, or the Product page.

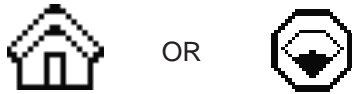

2. Select the Target Rate.
3. Enter the Target Rate value used during calibration of the product meter.

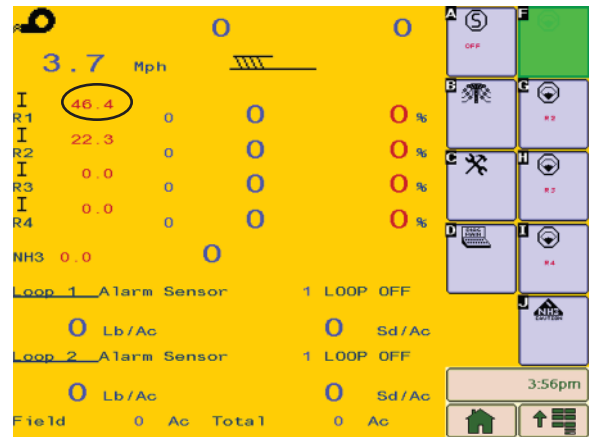

The Home Page

Note

The units for the target rate are either pounds per acre (lbs/ac) when using SAE units or kilograms per hectare (kg/ha) when using Metric units.

Setting Motor Cal Value for a GD System

Although a ground drive system does not use a motor driven product meter, the Motor Cal value in the D3 System must be set to ensure that the Bin Fill indication (and accumulation log) on the VT is correct. (After setting the Bin Fill Lbs and %, the D3 System continuously determines the current Bin Fill value by subtracting the product applied to the field.)

You must calculate and enter a Motor Cal value based on the amount (weight) of product delivered per revolution of the meter.

Using information gathered while setting up the meter, calculate the Motor Cal values using the formula shown on the right.

$$\frac{\text{Weight in bag (oz)}}{\text{Number of turns of crank}} = \text{Motor Cal value}$$

Set the Motor Cal value in the D3 System as follows:

1. On the VT, navigate to the Product page.
2. Select Motor Cal.
3. Enter the calculated Motor Cal value.



Variable Rate Drive Calibration and Operation

Calibration is done in four parts. First, you must prepare the system for calibration. Second, you prime the meter. Third, you take a sample and weigh it. Finally, you enter the sample, or Accumulated weight into the virtual terminal.

Preparing to Calibrate the Meter

Hydraulic power is needed for calibration. The following procedure sets up the air system for the calibration procedure.

1. Ensure that the air system's hydraulic lines are connected to a tractor.
2. Verify that the tractor hydraulic remote for the blower is in neutral until hydraulic power is needed.
3. Ensure that the monitor wire harness is properly connected to the tractor.
4. Power up the monitor in the tractor.
5. Verify that the VT in the cab is communicating with the Air System ECU.
6. Ensure that the meter door is properly attached to the meter.
7. Ensure the bin is at least 25% full of the product that will be applied.
8. Set the meter gate to the appropriate position for the rate being applied.
9. Pull the Auger Selector Valve out to bypass flow from the blower to the auger.
10. Check to make sure the auger control valve is in neutral.
11. Actuate the tractor remote controlling the blower circuit.
12. Make sure the blower is not spinning for the following steps.
13. If the blower is spinning, check the selector valve to ensure the blower flow is being diverted to the auger circuit.
14. Open the cleanout door below the meter you wish to calibrate.



The Auger Selector Valve



Adjusting the Meter Gate

Note

Open the gate approximately 1" for every 15 lbs/acre of application rate. This will provide the best meter performance for normal seeding conditions.

The meter must be calibrated if:

- *The gate setting has been changed*
- *A different product is being used*
- *A different meter roll is being used*

Each meter must be calibrated individually, even if all the gates are set the same.

Priming the Meter

To ensure accurate calibration, the meter must be primed with product.

1. On the ECU keypad, locate the button with the number corresponding to the meter you are calibrating. This is called the ECU Calibration button.
2. Press the ECU Calibration button once.
The meter roll begins spinning.
3. Allow the meter to spin 2 to 3 revolutions to ensure that the meter is full of product.
4. Press the same button again to stop the meter.
The meter is now primed.



Note

Each time the calibration button on the ECU is pressed to activate the meter the ECU counts the revolutions of the meter roll. This count is reset each time this process is performed. Once you stop the meter roll, the bag must be weighed. If you did not collect enough product in the bag to obtain a measurable weight, you must dump the bag and start over with an empty bag.

Caution



Do not push the buttons on the ECU when not calibrating. This will activate calibrate mode and the meter will run continuously when the hydraulics are turned back on.

Note

To calibrate a product meter it must be enabled (active) on its Product page (I).

Taking a Sample for Calibration

1. Using the weigh scale included with your system, hang the calibration bag (also included) on the scale and turn the adjustment dial to zero out the weight of the bag.
2. Place the calibration bag below the cleanout opening.
Be careful to ensure all product will flow into the bag.
3. Press the ECU Calibrate button to activate the meter.
4. Allow the meter to spin until the bag is at least half full.
5. Press the ECU Calibrate button again to stop the meter.
6. Weigh the bag with the supplied scale.
7. Convert the weight to ounces and record the value.
This value is the Accumulated Weight value you will enter into the VT.
8. Repeat the previous steps to obtain sample weights for the rest of the meters.
9. When all the weights have been found, go back to the tractor and enter the calibration weights into the Product page on the Virtual Terminal.



Entering Accumulated Weight on the VT

1. On the Home page, press the soft key for the desired bin.
The Product page for the selected bin appears
2. On the Product page, select Accum (oz).
3. Enter the accumulated weight value obtained in the meter calibration procedure in ounces.

Repeat Steps 1 to 3 for each additional bin.

Note

Once you enter the Accum value the monitor automatically calculates the Motor Cal value. The Motor Cal value is the number of ounces (oz) of product applied per revolution of the meter roller. E.g. If the Motor Cal value is 16.80, The meter will deliver 16.80 oz of material during each revolution of the meter roll.

Calibrating with the Product Page VR Cal Softkey

If you prefer, during calibration you can use the VR Cal softkey on the Product page (for the product currently being calibrated) to start and stop the metering roll, instead of using the ECU Calibrate button. The calibration procedure (in the previous sections) is identical except that you must navigate to the Product page for the product being calibrated, and then press the VR Cal softkey to start the metering roll and press it again to stop the metering roll.

Manually setting Motor Cal Value for a VR system

Set the Motor Cal value in the D3 System as follows:

1. On the VT, navigate to the Product page.
2. Select Motor Cal.
3. Enter the desired Motor Cal value.



Rotations	0.0	Rev
Accum	0.0	oz
Motor Cal	3.53	oz/Rev
Min Speed	0.4	Mph

What is Min and Max Speed?

After the Accum value has been entered, the D3 System calculates the Min Speed and Max Speed values (in mph). These values define the range of speeds you can travel while maintaining accurate application per acre. During planting, if you travel at a speed less than the minimum or greater than the maximum your application accuracy will be compromised.



Note

If you use this method you have to move back and forth from the air cart to the tractor. Having one person in the tractor cab and another at the air cart may be more convenient than using this method with only one person.

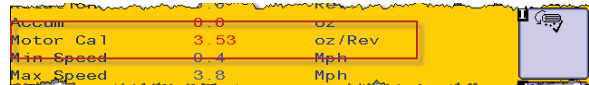

Accum	0.0	oz
Motor Cal	3.53	oz/Rev
Min Speed	0.4	Mph
Max Speed	3.8	Mph

Setting the Target Application Rate

Before beginning to seed, you must enter your target application rate for each product on the Home page or Product pages.

1. On the VT, navigate to the Home page, or the Product page.



OR



2. Select the Target Rate.
3. Enter the desired Target Rate value.
4. Verify that the value you entered is displayed on the Home page.



Note

The units for the target rate are either pounds per acre (lbs/ac) when using SAE units or kilograms per hectare (kg/ha) when using Metric units.

Setting up and Using Delta Step

Each product bin has a Delta Step feature. There are two Delta Step softkeys: a Delta Step Up and a Delta Step Down. When a Delta Step key is pressed it changes the application rate by a preset %. You can set up the Delta Step (%) Size on the Product page for each bin.

To set up the Step Size:

1. On the Home page, press the soft key for the desired bin (R1, R2, etc).

The Product page for the selected bin appears.

2. On the Product page, select **Step Size**.
3. Enter the desired Step Size value.

(E.g. 25% will increase or decrease the rate by 25%.)

While applying product you can use the Delta Step Up or Delta Step Down soft keys (on the Product page) to increase or decrease the application rate by the Step Size %.

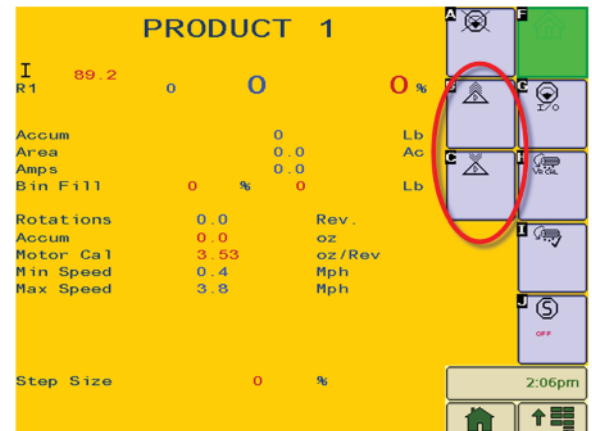

Delta Step Up



Delta Step Down



Note

Delta Step is set on each bin for that particular product. When Delta Step Up or Down is pressed, it will only control the bin related to that page.

Variable Rate Application Using a VT with Mapping

To set up variable rate application using a VT with mapping capabilities refer to the documentation that comes with your mapping-capable virtual terminal.

WHEAT

High Capacity Flute P/N 65705
1/4" WIDE X 1/2" DEEP BARS

GROUND DRIVE ONLY
17T GEAR BOX SPROCKET W/ 18.4 R26 TIRES
15T GEAR BOX SPROCKET W/ 23.1 R26 TIRES

WIDTH (FT)	APPLICATION RATE (LBS PER ACRE)																		
	60	70	80	90	100	110	120	130	140	150	160	170	180	190	200	210	220	230	240
20	2.7	3.1	3.6	4.0	4.5	5.0	5.4	5.8	6.3	6.7	7.2	7.6	8.1	8.5	8.9	9.4	9.8	10.3	10.8
25	3.4	3.9	4.5	5.0	5.6	6.2	6.8	7.3	7.8	8.4	8.9	9.5	10.1	10.6	11.2	11.8	12.3	12.9	13.4
30	4.1	4.7	5.4	6.0	6.8	7.4	8.1	8.8	9.4	10.1	10.7	11.4	12.1	12.8	13.4				
35	4.7	5.5	6.3	7.0	7.9	8.7	9.5	10.2	10.9	11.7	12.5	13.3							
40	5.4	6.3	7.2	8.0	9.0	9.9	10.8	11.7	12.5	13.4									
45	6.1	7.1	8.1	9.0	10.1	11.1	12.2	13.2											
50	6.8	7.9	9.0	10.0	11.3	12.4	13.5												
55	7.4	8.7	9.9	11.0	12.4	13.6													
60	8.1	9.4	10.8	12.0	13.5														

APPROXIMATE POINTER SETTING

ROLL PROFILE

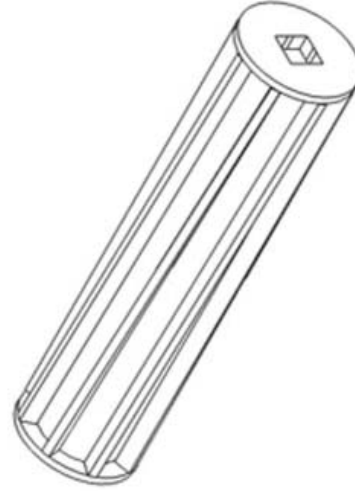
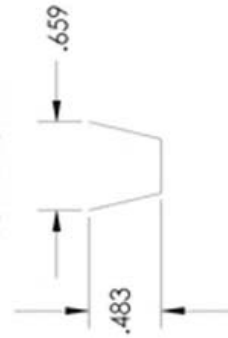

FERTILIZER (60 LBS PER CUBIC FT.)

High Capacity Flute P/N 65705
1/4" WIDE X 1/2" DEEP BARS

GROUND DRIVE ONLY
17T GEAR BOX SPROCKET W/ 18.4 R26 TIRES
15T GEAR BOX SPROCKET W/ 23.1 R26 TIRES

APPLICATION RATE (LBS PER ACRE)

WIDTH (FT)	APPLICATION RATE (LBS PER ACRE)																		
	60	70	80	90	100	110	120	130	140	150	160	170	180	190	200	210	220	230	240
20	2.3	2.7	3.1	3.5	3.8	4.2	4.6	5.0	5.4	5.8	6.1	6.5	6.9	7.3	7.7	8.1	8.4	8.8	9.2
25	2.9	3.4	3.8	4.3	4.8	5.3	5.8	6.2	6.7	7.2	7.7	8.2	8.6	9.1	9.6	10.1	10.6	11.0	11.5
30	3.5	4.0	4.6	5.2	5.8	6.3	6.9	7.5	8.1	8.6	9.2	9.8	10.4	10.9	11.5	12.1	12.7	13.2	13.8
35	4.0	4.7	5.4	6.0	6.7	7.4	8.1	8.7	9.4	10.1	10.8	11.4	12.1	12.8	13.4				
40	4.6	5.4	6.1	6.9	7.7	8.4	9.2	10.0	10.8	11.5	12.3	13.1	13.8						
45	5.2	6.0	6.9	7.8	8.6	9.5	10.4	11.2	12.1	13.0	13.8								
50	5.8	6.7	7.7	8.6	9.6	10.6	11.5	12.5	13.4										
55	6.3	7.4	8.4	9.5	10.6	11.6	12.7	13.7											
60	6.9	8.1	9.2	10.4	11.5	12.7	13.8												

APPROXIMATE POINTER SETTING

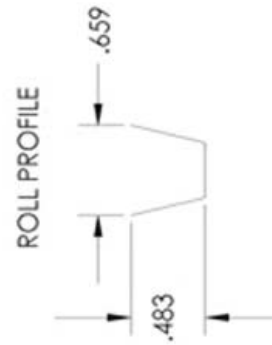
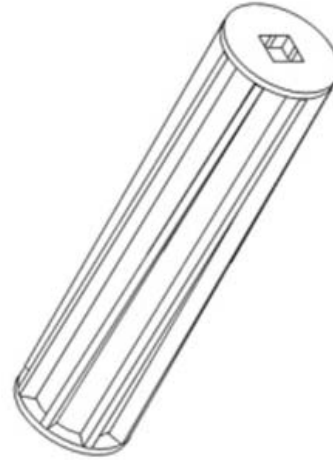

SOYBEANS

High Capacity Flute P/N 65705
1/4" WIDE X 1/2" DEEP BARS

GROUND DRIVE ONLY
17T GEAR BOX SPROCKET W/ 18.4 R26 TIRES
15T GEAR BOX SPROCKET W/ 23.1 R26 TIRES

WIDTH (FT)	APPLICATION RATE (LBS PER ACRE)																		
	60	70	80	90	100	110	120	130	140	150	160	170	180	190	200	210	220	230	240
20	3.1	3.6	4.1	4.6	5.2	5.7	6.2	6.7	7.2	7.7	8.2	8.8	9.3	9.8	10.4	10.9	11.4	11.9	12.4
25	3.9	4.5	5.2	5.8	6.4	7.1	7.8	8.4	9.0	9.6	10.3	10.9	11.6	12.2	12.9	13.6			
30	4.7	5.4	6.2	6.9	7.7	8.6	9.3	10.1	10.8	11.6	12.3	13.1	13.9						
35	5.4	6.3	7.2	8.0	9.0	10.0	10.9	11.7	12.6	13.5									
40	6.2	7.2	8.3	9.2	10.3	11.4	12.4	13.4											
45	7.0	8.1	9.3	10.4	11.6	12.8	14.0												
50	7.8	9.1	10.3	11.5	12.9	14.0													
55	8.5	10.0	11.4	12.6	14.2														
60	9.3	10.9	12.4	13.8															

APPROXIMATE POINTER SETTING

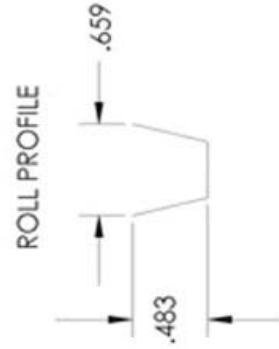
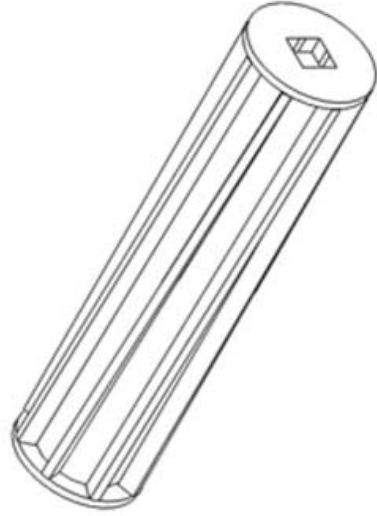

BARLEY

High Capacity Flute P/N 65705
1/4" WIDE X 1/2" DEEP BARS

GROUND DRIVE ONLY
17T GEAR BOX SPROCKET W/ 18.4 R26 TIRES
15T GEAR BOX SPROCKET W/ 23.1 R26 TIRES

APPLICATION RATE (LBS PER ACRE)

WIDTH (FT)	APPLICATION RATE (LBS PER ACRE)																		
	60	70	80	90	100	110	120	130	140	150	160	170	180	190	200	210	220	230	240
20	3.4	3.9	4.5	5.0	5.6	6.2	6.7	7.3	7.8	8.4	8.9	9.5	10.1	10.7	11.2	11.8	12.3	12.9	13.4
25	4.2	4.9	5.6	6.3	7.0	7.7	8.4	9.1	9.8	10.5	11.2	11.9	12.6	13.3					
30	5	5.8	6.7	7.6	8.4	9.2	10.1	10.9	11.8	12.6	13.4								
35	5.9	6.8	7.8	8.8	9.8	10.8	11.7	12.8	13.7										
40	6.7	7.8	8.9	10.1	11.2	12.3	13.4												
45	7.5	7.0	10.0	11.4	12.6	13.8													
50	8.4	9.8	11.1	12.6	14.0														
55	9.2	10.7	12.2	13.9															
60	10.1	11.7	13.4																

APPROXIMATE POINTER SETTING

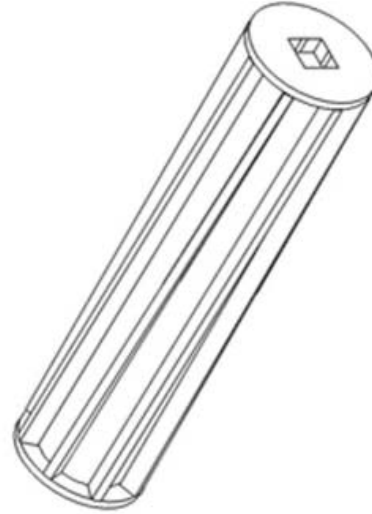

ROLL PROFILE



System Capacity Charts

The following charts provide information on blower capacity for various implement widths at a range of ground speeds. The values in the charts represent the maximum field rate per airstream, in lbs/acre.

Parameters:

5000 rpm

Single air stream with one 5 inch primary and at least four 2.5 primary hoses, 160 lbs./min max product delivery rate

One primary manifold

Max delivery rate (lbs/min) at 5000 rpm blower speed

Imp Width Feet	Ground Speed (mph)												
	3.0	3.5	4.0	4.5	5.0	5.5	6.0	6.5	7.0	7.5	8.0	8.5	9.0
30	880	754	660	587	528	480	440	406	377	352	330	311	293
35	754	647	566	503	453	411	377	348	323	302	283	266	251
40	587	503	440	391	352	320	293	271	251	235	220	207	196
45	587	503	440	391	352	320	293	271	251	235	220	207	196
50	528	453	396	352	317	288	264	244	226	211	198	186	176
55	480	411	360	320	288	262	240	222	206	192	180	169	160
60	440	377	330	293	264	240	220	203	189	176	165	155	147

Parameters:

6000 rpm

Single air stream with one 5 inch primary and at least four 2.5 primary hoses, 180 lbs./min max product delivery rate

One primary manifold

Max delivery rate (lbs/min) at 6000 rpm blower speed

Imp Width Feet	Ground Speed (mph)												
	3.0	3.5	4.0	4.5	5.0	5.5	6.0	6.5	7.0	7.5	8.0	8.5	9.0
30	990	849	743	660	594	540	495	457	424	396	371	349	330
35	849	727	636	566	509	463	424	392	364	339	318	299	283
40	743	636	557	495	446	405	371	343	318	297	278	262	248
45	660	566	495	440	396	360	330	305	283	264	248	233	220
50	594	509	446	396	356	324	297	274	255	238	223	210	198
55	540	463	405	360	324	295	270	249	231	216	203	191	180
60	495	424	371	330	297	270	248	228	212	198	186	175	165

Note

These values are based on optimum conditions. Actual system capacity can be reduced by variances in the following factors:

- Type of product being distributed in the air system
- Product Moisture
- Air temperature
- Elevation
- Humidity

System Capacity Charts

The following charts provide information on blower capacity for various implement widths at a range of ground speeds. The values in the charts represent the maximum field rate per airstream, in lbs/acre.

Parameters:

5000 rpm

Single air stream with two 4 inch primaries and at least eight 2.5 primary hoses, 190 lbs./min max product delivery rate

Two primary manifolds

Max delivery rate (lbs/min) at 5000 rpm blower speed

Imp Width Feet	Ground Speed (mph)												
	3.0	3.5	4.0	4.5	5.0	5.5	6.0	6.5	7.0	7.5	8.0	8.5	9.0
30	1045	896	784	697	627	570	523	482	448	418	392	369	348
35	896	768	672	597	537	489	448	413	384	358	336	316	299
40	784	672	588	523	470	428	392	362	336	314	294	277	261
45	697	597	523	464	418	380	348	322	299	279	261	246	232
50	627	537	470	418	376	342	314	289	269	251	235	221	209
55	570	489	428	380	342	311	285	263	244	228	214	201	190
60	523	448	392	348	314	285	261	241	224	209	196	184	174

Parameters:

6000 rpm

Single air stream with two 4 inch primaries and at least eight 2.5 primary hoses, 220 lbs./min max product delivery rate

Two primary manifolds

Max delivery rate (lbs/min) at 6000 rpm blower speed

Imp Width Feet	Ground Speed (mph)												
	3.0	3.5	4.0	4.5	5.0	5.5	6.0	6.5	7.0	7.5	8.0	8.5	9.0
30	1210	1037	908	807	726	660	605	558	519	484	454	427	403
35	1037	889	778	691	622	566	519	479	444	415	389	366	346
40	908	778	681	605	545	495	454	419	389	363	340	320	303
45	807	691	605	538	484	440	403	372	346	323	303	285	269
50	726	622	545	484	436	396	363	335	311	290	272	256	242
55	660	566	495	440	396	360	330	305	283	264	248	233	220
60	605	519	454	403	363	330	303	279	259	242	227	214	202

Note

These values are based on optimum conditions. Actual system capacity can be reduced by variances in the following factors:



- Type of product being distributed in the air system
- Product Moisture
- Air temperature
- Elevation
- Humidity

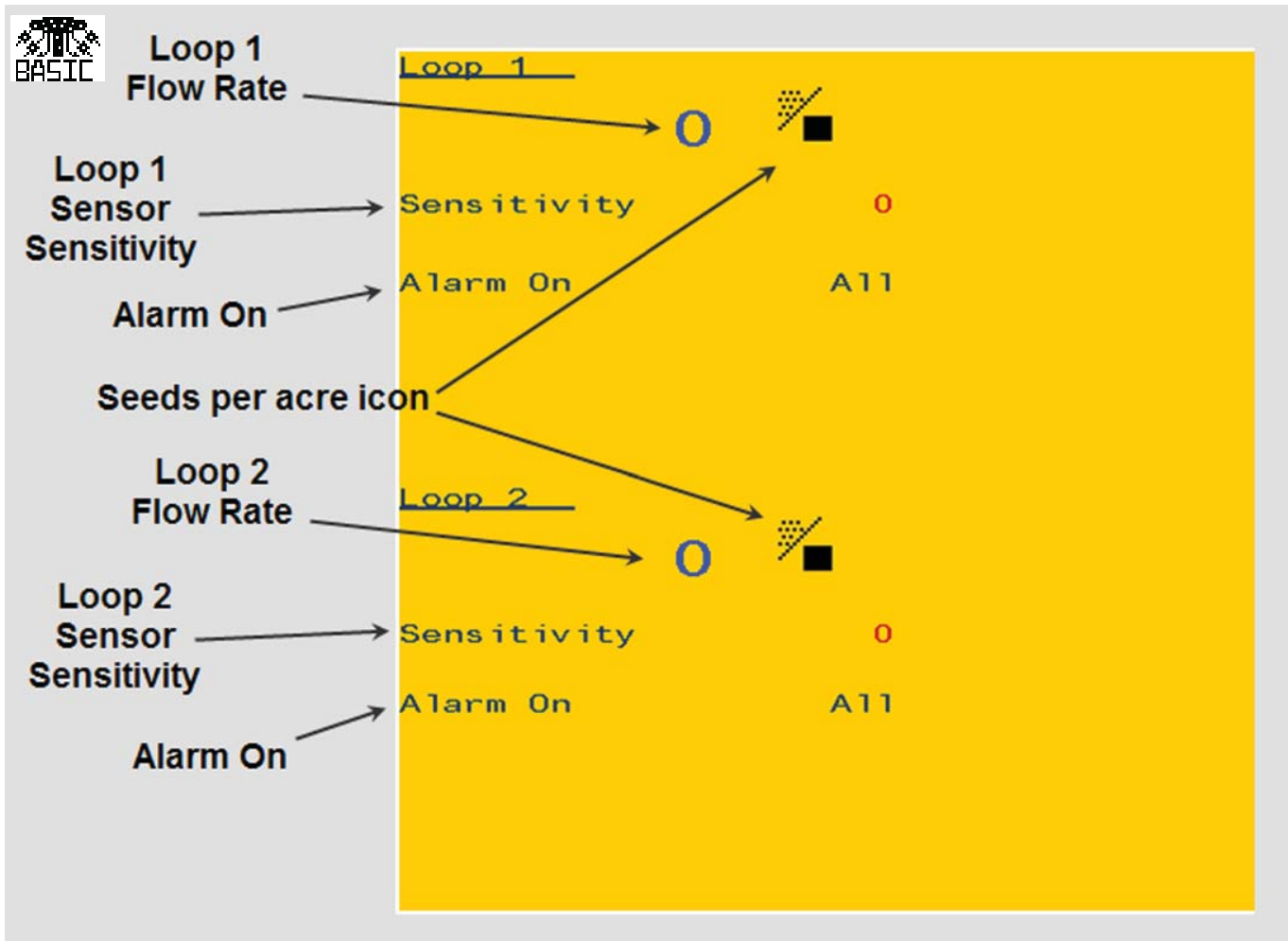

ART SYSTEM - SETUP AND OPERATION

The ART Seed Monitoring System uses infrared sensors to measure seed (or fertilizer) application rate and check for blockages. The sensors operate on a similar principle to that of a motion detector in a security system. As seeds or fertilizer moves through the flow sensor it is detected by infrared beams and detectors. The sensors provide an indication of the number of seeds flowing past the sensor, and can provide a blockage alarm if the flow decreases below a value set by the Sensitivity setting.

The system can have two sensor loops so that seed and fertilizer can be measured separately in double-shoot systems. Sensors are connected in a loop, each communicating in turn, and each including built-in diagnostics. The system determines the number of sensors in a loop automatically. A maximum of 120 sensors can be connected in a loop.



Soft Key Icon	Description
	Home (or Main)
	Manual Master Work Switch
	ART Diagnostics

Soft Key Icon	Description
	Loop Status (Loop1, Loop2, Loop 1&2: 1 to 60, Loop 1&2: 61 to 120)
	Product Diagnostics

Setting Sensor Sensitivity

The ART Seed Monitoring System includes a Sensitivity setting for the sensor monitoring seed flow. If a sensor measures fewer seeds per second than set by the sensitivity value, a blockage alarm occurs.

To set up the Sensitivity:

1. On the Home page, press the ART BASIC soft key.



The ART BASIC page appears.

2. Select **Loop 1 Sensitivity**.
3. Enter an initial sensitivity value between 1 and 125. (Refer to the table below for approximate sensitivity values.)
4. Ensure that there are no blockages and begin seeding.
5. Increase the sensitivity value until the system alarms. Then, decrease the sensitivity 3 to 5 units at a time until the system no longer shows blockage alarms.
6. Repeat the procedure for Loop 2.

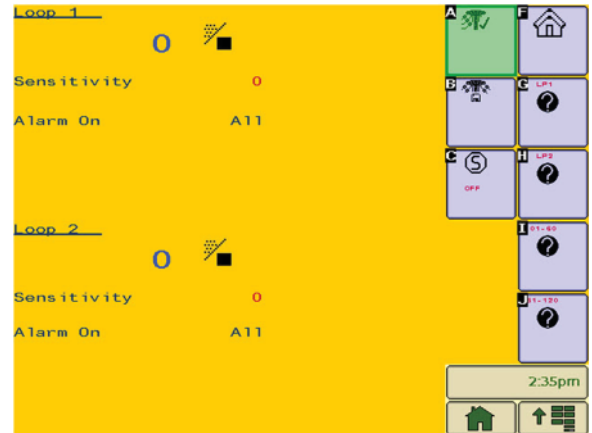

Sensitivity	Seeds/second
0	Loop is off
1	1 seed / 30 sec
5	1 seed / 20 sec
10	1 seed / 10 sec
15	1 seed / sec
20	7 seeds / sec
30	17 seeds / sec
40	27 seeds / sec
50	44 seeds / sec
60	80 seeds / sec
70	148 seeds / sec
80	281 seeds / sec
90	539 seeds / sec
100	1043 seeds / sec
110	2019 seeds / sec
120	4400 seeds / sec
121	4800 seeds / sec
122	5300 seeds / sec
123	5800 seeds / sec
124	6400 seeds / sec
125	7000 seeds / sec

Notes

- Try to set the Sensitivity value as high as possible without causing frequent false alarms.
- A Sensitivity value of 0 disables the power and alarms to the seed sensor loop.
- The default Sensitivity value is 15.
- If sensitivity is set to less than 15 the scanning loop runs more slowly, giving sensors a longer time to count seeds. This enables the system to provide sensitivity as low as 1 seed / 30 seconds.

Setting the Alarm On Feature

Using the Alarm On feature to configure the ART System to monitor for blockages on all sensors, or only the even or odd numbered sensors.

This features allows you to use All sensors when using standard shank spacing of 15 inches, or alternate sensors if your implement is set up for 30 inch rows.

Setting the Alarm On setting (on either or both Loop 1 and Loop 2) to Even enables sensors 2, 4, 6, 8, etc. Setting Alarm On to Odd enables sensors 1, 3, 5, 7, etc

To set the Alarm On feature:

1. On the Home page, press the ART BASIC soft key.
The ART BASIC page appears.
2. Select **Loop 1 Alarm On**
3. Configure Alarm On as follows:
 - a. If you are using standard 15 inch shank spacing, select All
 - b. If you are using 30 inch shank spacing, determine whether you want to enable Even or Odd sensors, and select appropriate option.

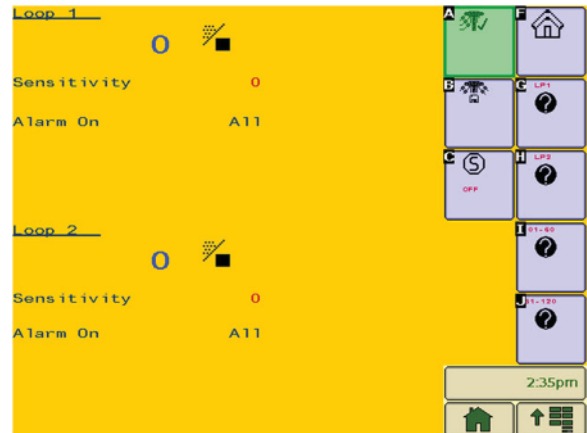

Using ART Loop Status Pages

The ART System provides four different status pages to assist the operator with monitoring the operational status of individual sensors.

- The Loop 1 Full Loop status page shows the status of all sensors (up to the maximum of 120) in ART Loop 1.
- The Loop 2 Full Loop status page shows the status of all sensors (up to the maximum of 120) in ART Loop 2.
- The Loop 1 and 2: 1 to 60 status page shows the status of the first 60 sensors for both loops.
- The Loop 1 and 2: 61 to 120 status page shows the status of the second 60 sensors for both loops.

This selection of pages enables you to monitor the status of the range of sensors that works best for you.

The following status information is provided for each sensor:

- XX indicates a blocked sensor
- CT indicates the sensor is counting seeds
- Hi indicates a High Rate condition exists
- Lo indicates a Low Rate condition exists
- -- indicates no sensor is installed
- CL indicates the sensor requires cleaning

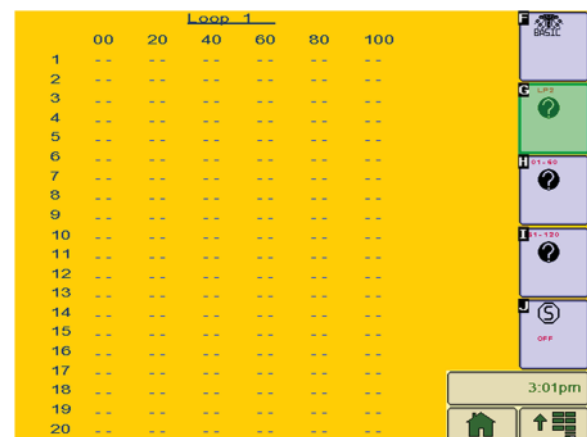

NH3 SYSTEM - SETUP AND OPERATION

Similar to the Product pages, the NH3 page is used for setup and calibration, but is also used to turn on and off the NH3 application.

The screenshot shows the NH3 1 control interface with the following elements and labels:

- NH3 On=1, Off=0**: Points to the top-left status indicator.
- Liquid Calibration Number (pulse/lb)**: Points to the 'NH3 0.0' value.
- Total Weight Accumulation**: Points to the 'Liquid Cal 0.00' value.
- Total Area Accumulation**: Points to the 'Area 0.0' value.
- Valve Gain (response speed)**: Points to the 'Gain 0' value.
- Target Rate**: Points to the '0' value in the top right.
- Actual NH3 Application Rate**: Points to the '0 %' value in the top right.
- Tank % Full**: Points to the '0 %' value in the middle right.
- NH3 Tank Fill Weight**: Points to the '0 Lb' value in the middle right.
- Purge (On/Off)**: Points to the 'OFF' status.
- NH3 Workswitch Mode (Auto/Manual)**: Points to the 'Auto' status.

Additional text on the screen includes: 'NH3 1', 'NH3 0.0', 'Liquid Cal 0.00 Pulses/Lb', 'Accum 0 Lb', 'Area 0.0 Ac', 'Gain 0', 'Tank Fill 0 % 0 Lb', 'Purge: OFF', 'Nh3 WS Mode: Auto', and a note: 'The purge function will open the valves for 6 seconds. Press the key 3 times to activate.'

Soft Key Icon	Description
	Home (or Main)
	Manual Master Work Switch
	Clear Accumulation
	Product On/Off

Soft Key Icon	Description
	NH3 Diagnostics
	NH3 Purge
	NH3 Work Mode

Calculating Liquid Calibration Number

To calibrate the NH3 application system you must first determine the Liquid Calibration Number associated with your flow meter. The Liquid Cal number is expressed in **pulses per pound of actual nitrogen (N)**. It is calculated using the actual number of pounds of N in a gallon of anhydrous ammonia and the pulses per unit volume number printed on a tag attached to your flow meter.

To calculate your Liquid Cal number:

1. Locate the Calibration Number Tag on your flow meter.
2. Note the units of your flow meter's Cal Number.

Depending on the brand of flow meter, the units may be given in:

- Pulses per pound of product
 - Pulses per 10 gallons of liquid
 - Pulses per gallon of liquid
 - Other
3. Using the units used on your flow meter, create a formula to calculate the Liquid Cal number. (This formula will be different from one flow meter to another because different manufacturers use different units.)
 4. Calculate the Liquid Cal number in **pulses per pound of actual nitrogen (N)**

Note

Anhydrous ammonia (NH3) contains 4.22 pounds of actual N per gallon.

Example

- (For this example we will use a typical Raven flow meter.)
- Raven flow meter tag: **710 pulses / 10 gallons**
- Actual N in NH3: **4.22 pounds / gallon**
- Liquid Cal number: **pulses/pound of N**

$$\frac{710 \text{ pulses}}{10 \text{ gallons}} \times \frac{1 \text{ gallon}}{4.22 \text{ lbs (N)}} = 16.82 \frac{\text{pulses}}{\text{lb(N)}}$$

Calibrating the NH3 Controller

To calibrate the NH3 controller:

1. On the Home page, press the NH3 soft key.



The NH3 page appears.

2. Select the NH3 application rate.
3. Enter the desired application rate in pounds of product (N) per acre.
4. Select **Liquid Cal**.
5. Enter the Liquid Calibration Number in pulses per pound.

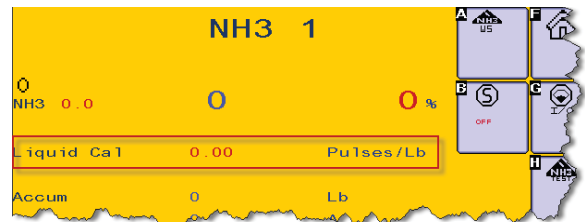

Checking and Fine-Tuning NH3 Calibration

To check the calibration of the NH3 controller:

1. Once the liquid cal value has been entered, and other functions on the NH3 screen are set, apply one tank of NH3 in the field.
2. Calculate the actual application rate per acres using the tare weight of the tank (NH3 used) and the total acres covered
3. Compare the actual application rate with your desired application rate.
4. On the Home page, press the NH3 soft key.
The NH3 page appears.
5. Select **Liquid Cal**.
6. Adjust your Liquid Cal number as follows:
 - a. If your actual application rate is less than your desired application rate, increase the Liquid Cal number.
 - b. If your actual application rate is greater than your desired application rate, decrease the Liquid Cal number

If further refinement of the calibration is needed, repeat the procedure.

Calibrating the NH3 Tank Fill Indication

To calibrate the NH3 Tank Fill indication:

1. On the NH3 page.
2. Select **Tank Fill, Lb**
3. Enter the estimated total pounds of product in the tank.
4. Select **Tank Fill, %**.
5. Enter the estimated tank fill value in %.

Purging the NH3 System

The NH3 system can be purged using the Purge soft key.

To Purge the NH3 system:

1. On the NH3 page, press the **Purge** soft key three (3) times.



The NH3 valves open for six (6) seconds, allowing NH3 to flow.

2. After six (6) seconds verify that the Purge indication on the NH3 page shows OFF and that flow has stopped.



Note

When fine tuning the actual applied rate you will have to use a trial and error method, making slight changes to the Liquid Cal number after applying each of several tanks of NH3. Typically adjust the Liquid Cal number by only .1 or .2 each time.

If you find that you have been under-applying, increase the Liquid Cal number by .1 or .2 until the actual applied rate is acceptable.

If you find that you have been over-applying, decrease the Liquid Cal number by .1 or .2 until the actual applied rate is acceptable.

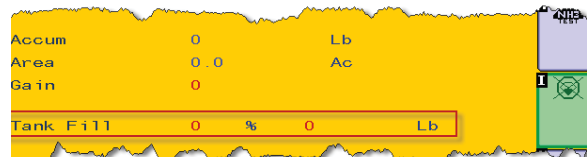

Caution!

Ensure no one is near the implement and that the tractor is upwind before purging the NH3 system.

Setting the NH3 Gain Value

The NH3 Gain value determines the speed at which the NH3 valve reacts to changes. Gain values may range from 0 to 4000, but note that values of either 0 or 4000 cause the valve to turn at its maximum speed. Between 0 and 4000, higher values cause the valve to move more quickly; lower values (except 0) cause it to move more slowly. Typically values of less than 700 may not move the valve fast enough. Gain is set on the NH3 page.

To set the Gain value:

1. On the NH3 page.
2. Select **Gain**
3. Enter a Gain value that moves the valve fast enough to react to changes satisfactorily but not so fast that it begins to oscillate. (Suggestion: Start at 2600)
4. In the field, test the speed of the valve and re-adjust as necessary.

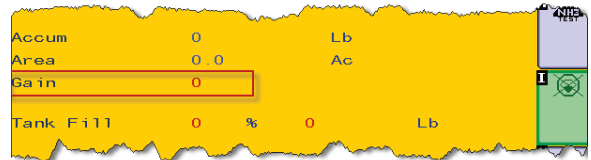

Note

- You will find that there is a maximum Gain value at which the motors and actuators on your system valves cannot open or close any faster.
- Usually, you should start the Gain value at approximately 2600. Adjust this value higher for faster response, or lower for slower response.

Setting NH3 Work Mode (Manual/Auto)

The NH3 controller can be operated in Manual or Auto NH3 Work Modes.

In Auto NH3 Work Mode, the NH3 system operates the same as dry products, and is tied to the Master Work Switch.

In Manual NH3 Work Mode, pressing the NH3 Product On/Off softkey (located on the NH3 page) turns on and off NH3 application manually. When the system is in Manual NH3 Work Mode, if NH3 application has been enabled using the NH3 Product On/Off softkey NH3 flows regardless of the Master Work Switch state. (If the implement is lifted at a headland NH3 continues to flow.)

To set the Auto/Manual NH3 Operation mode:

1. On the NH3 page, press the NH3 WS softkey to toggle the NH3 Work Mode.



2. Verify that the **NH3 WS Mode** has changed to the desired mode.



The NH3 Product On/Off softkey



Note

NH3 will not flow unless the implement is travelling at least 1.5 mph, regardless of whether the NH3 Work Mode is in Automatic or Manual.

Note

When operating in Manual NH3 Work Mode, switching the system Master Work Switch to Off does not turn off NH3 flow.

Testing NH3 System Components

The LQD Diagnostics page provides information about the operational state of the NH3 system. It is most commonly used by service personnel for testing, but you can also use it to test the NH3 valves, turning them on and off.

To test the NH3 valve operation:

1. On the Home page, press the NH3 soft key.



The NH3 page appears.

2. On the NH3 page, press the NH3 Diagnostics soft key.



The LQD Diagnostics page appears.

3. Select **Shutoff Control**.
4. Select **On** to open the valves.
The NH3 valves open and allow NH3 to flow.
5. Select **Off** to close the valves.



Caution!

Ensure no one is around the implement and that the tractor is upwind before using this function.



Warning!

The values in this screen override the normal operation of the system. Use with caution!

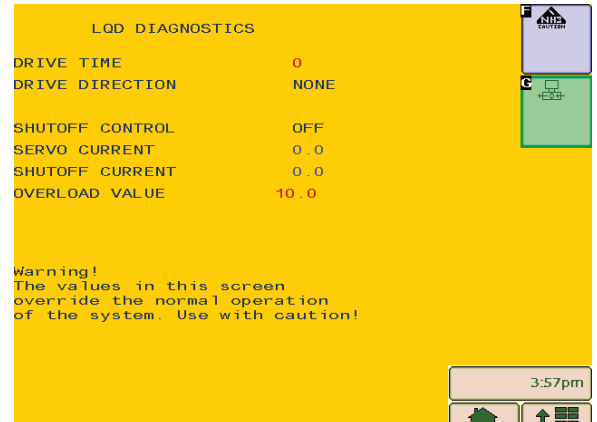

Tip!

It may be easier to use the NH3 Purge function on the NH3 page to check the operation of the NH3 valves.

MECHANICAL SYSTEMS - MAINTENANCE AND TROUBLESHOOTING

Routine Maintenance

Drive Line and Steering

Lubricate all drive line bearings and steering components every 50 hours with a SAE multipurpose grease.

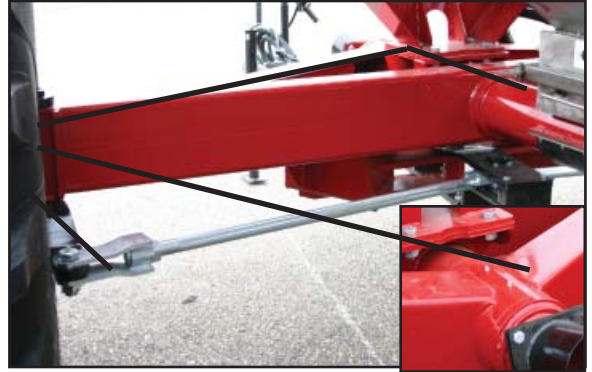

Gear Box

The gear box is filled at the factory and requires no maintenance. Service is required only if oil leaks become visible.



Hydraulic Motor

The hydraulic motor can only be damaged by heat or foreign material. Keep your tractor hydraulic oil and filter serviced regularly to ensure long life from your hydraulic components.



Wheel Bearings

Annually check wheel bearings for tightness. Adjust if needed. Repack every three (3) years.

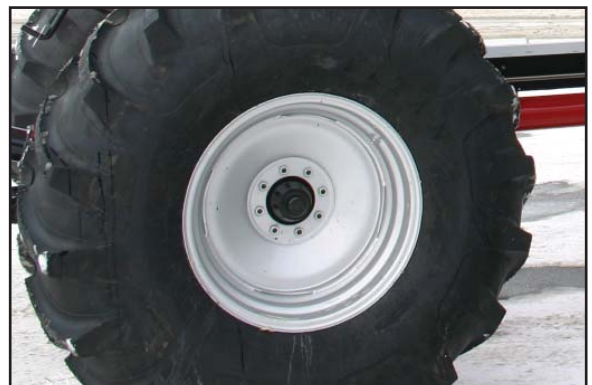

Changing Metering Rolls - Ground Drive System

To change metering rolls on a GD System:

1. Close the meter gate or ensure the bin is empty.
2. Remove the meter door and set aside.
3. Remove the chain from the meter drive sprocket. Do not remove the sprocket.
4. Remove the two nuts that hold the bearing on the meter shaft (sprocket end only).
5. Pull the shaft out of the meter while holding on to the meter roll.
6. Remove the meter roll.
7. Re-assemble the meter in reverse order with the desired flute.

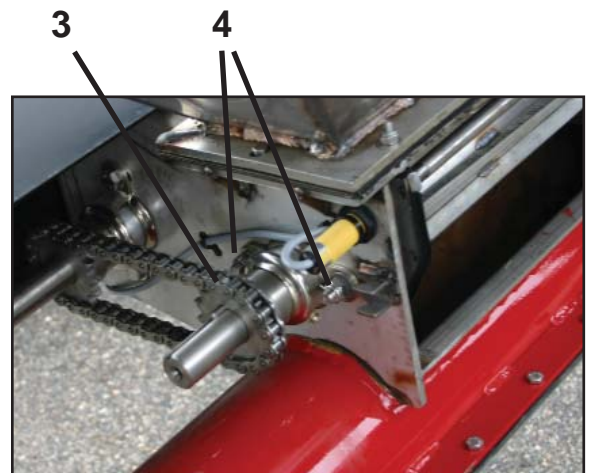

Changing Metering Rolls - Variable Rate System

To change metering rolls on a VR System:

1. Close the meter gate or ensure the bin is empty.
2. Remove the meter door and set aside.
3. Remove the (2) ½" bolts holding the hydraulic motor to the motor mount.
4. Remove the two nuts that hold the bearing on the meter shaft (motor-end only).
5. Pull the shaft out of the meter (with the motor still attached) while holding on to the meter roll.
6. Remove the meter roll.
7. Re-assemble the meter in reverse order with the desired meter roll.



Meter Roll Options

All of the Amity meter rollers are constructed of stainless steel for lifetime performance.

Three meter roll options are available.

The high capacity roll has eight ½" deep bars and is used for most applications.

The medium capacity roll has twelve ¼" deep bars and is used on smaller machines or for consistently lower seeding or fertilizing rate.

The canola roll has a pattern of shallow depressions for very low seeding rate.

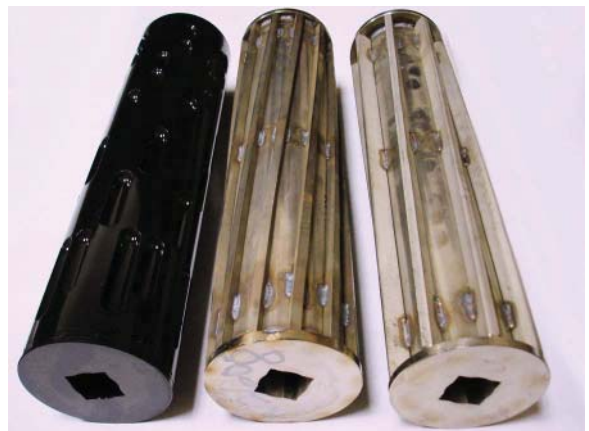

Other Meter Adjustments

The following adjustments are done at the factory and should only be done by a trained service technician.

Shims

- The meter roll should have a small gap (.030") between the roll and the meter housing for proper operation. If the gap is too large product can leak around the meter roll into the air stream. If the gap is too tight the meter roll will bind on the housing and cause problems with the meter drive system.
- A .030" thick shim (Amity P/N 65744) can be installed between the meter roll and the meter housing to reduce this gap. The meter shaft needs to be removed to install this shim, see the section on changing meter rolls on the procedure to remove the shaft.
- Ensure the meter roll turns freely after installing or removing any shims. If the meter roll does not turn freely, DO NOT operate the air system until enough shims have been removed to allow the meter roll to turn freely.



Deflector Block

The black plastic deflector block in the rear of the meter prevents seed from flowing around the back side of the meter roll. If needed, this block can be adjusted vertically to increase or decrease the clearance to the meter roll. To adjust, loosen the two nuts on the back side of the meter housing, move the block to the desired position, and tighten the nuts to lock the block into place.

Meter Door and Cleanout Door Latches

The tension on these latches can be adjusted to increase or decrease the preload on the meter door and the cleanout door. If the preload is too small, the doors will not seal properly. If the tension is too tight, the latches will be difficult to close. The tension can be adjusted by unlocking the latch and screwing the two stop-nuts evenly in or out. Ensure the door preload is adequate before putting the unit back into service.



Meter Door Tray

The tray on the meter door can be adjusted vertically in order to increase or decrease the tension between the rubber seal on the tray and the meter roll. To adjust, loosen the two nuts holding the tray to the meter door, move the tray to the desired position, and tighten the nuts to lock the tray into place.



Gear Box

The gear box is filled with oil at the factory and does not require service. If a visible leak appears at one of the seals, repair the box and fill half-full with 85W90 oil.

The drive line components are protected by a shear pin located on the gearbox coupler. If the pin fails, determine the reason for the failure, remove, and install a new shear pin.

To replace the shear pin:

1. Loosen the bolt on the locking tab and rotate the tab out of the machined groove in the shear pin.
2. Remove any broken shear pin pieces and line up the holes in the coupler with the hole in the shaft.
3. Install a new shear pin.
4. Rotate the lock tab into the machined groove on the shear pin and tighten the bolt on the tab.



Gear box



Gear box shear pin

Mechanical Systems Troubleshooting: Common Problems and Solutions

Symptom	What it means	Recommended Action
Seed cups will not engage	Shear pin may have broken	Clear obstruction and replace pin.
	Clutch has no power going to it	Be sure there is power to clutch using test light.
	Clutch may have failed	Replace clutch.
Seed cups will not disengage	Sprocket on clutch may have frozen shaft	Check plastic bearing under sprocket.
	Short in monitor is supplying power to the clutch.	Find short and repair.
Seed is flowing without cups turning. (A small amount of seed flow is normal and not a cause for concern.)	Rubber deflector is not down tightly on flute.	Lower the deflector.
	Rubber wiper on seed cup door damaged or not up tightly against flute.	Raise door or replace rubber wiper if damaged.
	Product is building up in air delivery system.	Increase blower speed.
Excessive seed cracking is occurring	Air stream velocity is too great.	Reduce blower speed or adjust blower baffle on dual air stream machines.
Seed boots are plugging	Turning corners too sharply with boots in the ground.	Always raise ground opener before making a sharp turn.
	Ground openers have been left in the ground when backing up.	Always raise ground opener before backing up.
Product distribution is uneven	A one inch hose may be plugged.	Re-route or cut 1" hoses to eliminate sags. Clear any obstruction in hoses or boots.
Uneven delivery rate	Loss of tank pressure.	Check tank lids for leaks. Inspect and replace faulty gaskets.
Oil showing up on seed lines	Shaft seal failure on hydraulic motor.	Replace seal. WARNING: DO NOT DISASSEMBLE HYDRAULIC MOTOR!! THE SHAFT SEAL IS AN EXTERNAL REPLACEMENT ITEM.
Hydraulic motor slow	Monitor set to wrong blower speed setting (See Monitor Section).	See Monitor Section
	Tractor is not putting out adequate oil.	Have tractor dealer inspect tractor hydraulics.
	Bad couplers.	Check couplers on tractor and hoses. Try different couplers.

Storage

- Fully open the seed meters.
- Open clean out doors on the bottom of the air tube.
- Clean any remaining product from tanks.
- Use water to thoroughly clean any compartment used for fertilizer
- Thoroughly clean fertilizer and dirt from cup area.
- Clean the inside of the seed meter door. Fertilizer, seed and dirt accumulate in this area.
- Clean any remaining product from the auger and leave the auger slide open.
- Oil chains.
- Grease all lubrication points.
- Check the gear box for visible leaks. If none, no service is required.
- Release the latch on the tank lids to relieve pressure on the lid gaskets.

D3 ISO MONITOR - OTHER SETTINGS

Although the D3 ISO System on your Air Cart has been setup at the factory, some settings and calibrations must be done for the products you will be using. Previous sections have described some of the key setup procedure. This section includes additional information that you may need.

Initial System Startup Parameters

On the Startup page:

- Select the Drive Type (EOH or Ground Drive) on your system
- Select the number of products (2, 3 or 4) included on your system
- Select whether your system includes NH3 (0 or 1)

On the Calibration page:

- Set up an approximate Speed Cal number (15.0 for Ground Drive, 18.0 for EOH, when using standard tires)
- Select the number of Fan Targets (2)

On the Sensor Types page:

- Set up all sensors in their appropriate channel

On the Sensor Logic page:

- Set up the meter box sensor for inverted logic

On the Product Diagnostics page for each product bin:

- Set the pulses per revolution to 1 for Ground Drive or 60 for EOH
- Set the Minimum RPM setting to 10
- Set the Maximum RPM setting to 100
- Set the Meter Cal RPM to 25

The following sections contain detailed procedures on how to configure these settings as well as other settings that you may need to setup.



Warning

*The system **MUST** be set up properly or your system will not operate correctly.*

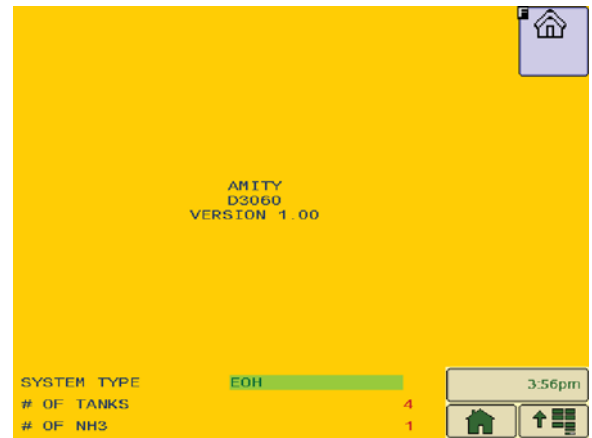

Note

- Each time the system is powered up the Startup page appears and requires you to enter the System Type, number of products and NH3 systems before proceeding.
- The Startup page only appears when the system is powered on.

Note

These settings are initial baseline values for the air cart system. In some cases (Speed Cal, Meter Cal, etc) you will calibrate them for a higher degree of accuracy. Calibration procedures are located in later sections of this manual.



Overview of the Calibration Page



The Calibration page (also sometimes called System Settings) is used for setup and calibration. It lists parameters that you can set based on the type of tractor, implement and virtual terminal you are using, as well as parameters set when you perform a calibration procedure.



CALIBRATION

Speed Calibration Number	Speed Cal	0.05	in		
	Width	480	in		Implement Width
Field Area Accumulation	Field	0	Ac		
	Total	0	Ac		Total Area Accumulation
Number of Seed Rows Used	Seed Rows	48			
	Fan Targets	2			Number of Fan Targets Used
Fan Alarm Values	Fan High	6500	Rpm		
	Fan Low	3000	Rpm		
	Shaft Targets	1			Number of Shaft Targets Used
Shaft Speed Alarm Values	Shaft High	999	Rpm		
	Shaft Low	100	Rpm		
Type of Speed Sensor Used	Test Speed	0.0	Mph		Simulated Speed Value
	TC TYPE	GROUND SPEED			
Type of Variable Rate	VR INDEX	JD			Type of Virtual Terminal Used
		1			

Soft Key Icon	Description
	Home (or Main)
	Manual Master Work Switch
	Clear Area Total (1 & 2)

Soft Key Icon	Description
	Distance Check
	Calibration Storage
	Sensor Assignment

Setting Speed Calibration

To set up the speed sensor on the commodity cart.

1. Measure a 400 ft distance in front of the implement.
2. Press the **Distance Check** soft key.



The Distance Check page appears.

3. Select **Distance**.
4. Clear the accumulated distance value.
5. Drive the implement the measured 400 ft and then stop.
6. Enter 400 ft as the Distance value.
The Speed Cal number will automatically be calculated and appear.
7. Press the **Calibration** soft key to return to the Calibration page.
8. Verify that the new Speed Cal value appears on the Calibration page.

Note

Typical Speed Cal values:

- GD w/18.4R26 Tire: 13.6"
- GD w/23.1R26 Tire: 15.0"
- VR w/18.4R26 Tire: 16.3"
- VR w/23.1R26 Tire: 18.0"
- Optional GPS speed sensor: 0.39

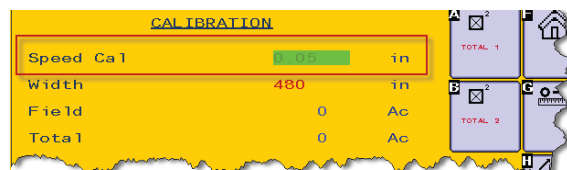
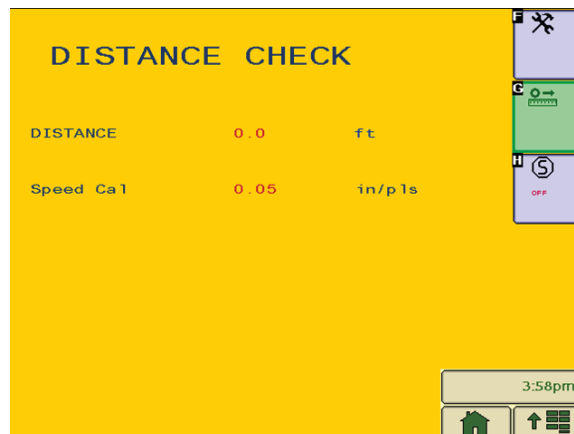

Setting Implement Width

To configure the monitor for the width of your implement:

1. On the Calibration page, select **Width**.
2. Enter the Width value in inches.
3. Verify that the correct Width value is displayed on the Calibration page.

Note

The Width value must be entered in inches. E.g. If your implement is 60 feet wide:

$$60 \text{ feet} \times 12 \text{ inches per foot} = 720 \text{ inches}$$

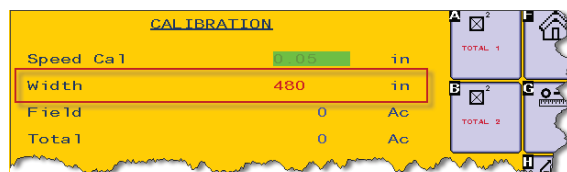

Resetting Field and Total Acres

Your ISOBUS system accumulates totals for the number of acres seeded in the current field as well as an overall total. These totals can be reset on the Calibration page.

To reset the Field acres total:

1. On the Calibration page, press the **Total 1** soft key once to reset the Field acres total to zero.



To reset the Total acres total:

2. On the Calibration page, press the **Total 2** soft key once, to reset the Total acres total.

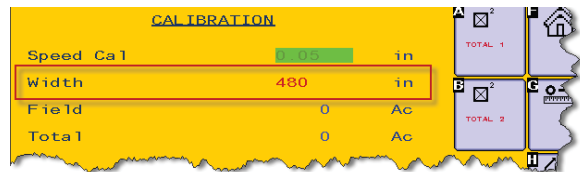

Setting the Number of Fan Targets

Fan targets are used on the blower fan to determine the fan speed. Use the following procedure to set the Fan Targets value to the total number of register points on the fan that pass in front of the fan sensor each revolution.

To set the Fan Targets value:

1. On the Calibration page, select **Fan Targets**.
2. Enter the number of targets used on your system.
3. Verify that the correct number of Fan Targets is displayed on the Calibration page.

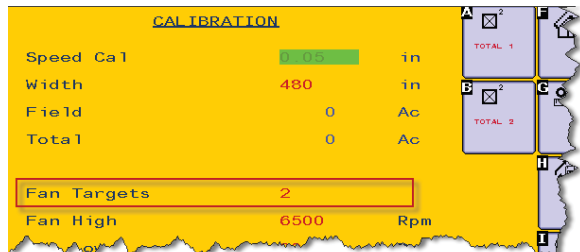

Setting Fan High and Low Speed Alarms

The values of your high and low fan alarms depend on your desired operational range.

To set the high and low fan RPM alarm limits:

1. On the Calibration page, select **Fan High**
2. Enter the RPM value at which you want the fan alarm to sound.
3. Verify that the correct Fan High alarm value is displayed on the Calibration page.

Repeat the procedure to enter the Fan Low alarm value.

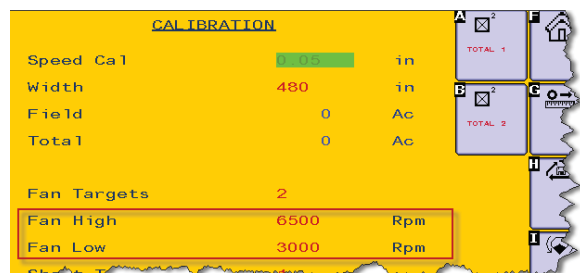

Shaft Settings

The Calibration page on your ISOBUS monitor includes settings for the number of Shaft Targets and Shaft High and Low RPM alarms. These settings are not used on your Amity air cart and you DO NOT have to configure them to operate your air cart.

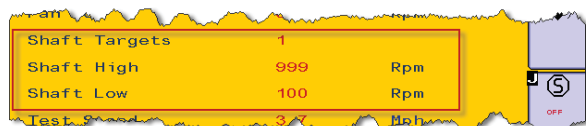

Setting the Speed Input Type

Using Speed Type setting, you can select and use any of the following speed inputs:

- A radar speed device on the commodity cart (ECU)
- A GPS speed input on the tractor
- A wheel speed sensor on the tractor
- A ground speed signal from the tractor computer system.

To select a Speed Type:

1. On the Calibration page, select **Speed Type**.
2. Select the appropriate Speed Type for your system.
3. Verify that the correct Speed Type is displayed on the Calibration page.

Notes

- A GPS speed signal is usually the most accurate speed input.
- Not all tractors provide GPS or ground speed signals. If this is the case, use a radar speed input connected to the ECU
- When using a GPS speed input, configure the Speed Sensor channel for **None** on the Sensor Assignment page.

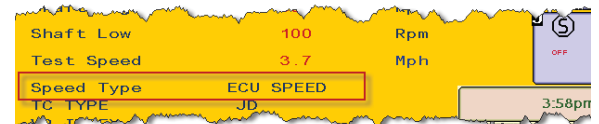

Setting the Type of VT (Task Controller)

Using the TC Type (Task Controller) setting you can select the type of virtual terminal you will be using with your air system. The type of task controller selected may affect the available operational features.

To select the required TC Type:

1. On the Calibration page, select **TC**.
2. Select the task controller type you will be using.
3. Verify that your selection is displayed on the Calibration page.

Note

If you are using a John Deere Green Star 2 (2600) monitor, select **JD**. For all other virtual terminals, select **OTHER**



Setting the VR Index

Using the VR Index setting, you can configure the system to apply a prescription application map to a selected bin on the air cart.

To select a bin number that you want to be used for variable rate application:

1. On the Calibration page, select **VR Index**.
2. Select the number of the bin you want to use for variable rate application.
3. Verify that your selection is displayed on the Calibration page.

Note

VR Index is only used if you have selected JD for your Task Controller (TC)



Turning On (Assigning) and Turning Off Sensors

On the Sensor Assignment page you can assign up to 32 sensor channels to specific sensors. Any sensor channel not assigned is turned off.

To assign a sensor to a channels (and turn it on):

1. Press the Sensor Assignment soft key.



The Sensor Types page appears.

2. Select the number of the sensor channel to be assigned.
3. Step through the options until the desired sensor type appears.
4. Select the sensor type.

To turn off a sensor:

1. Select the number of the sensor channel to be assigned.
2. Select **Off**.

Note

A list of sensor functions and designations used with the ISO Air System are listed on the next page.

SENSOR TYPES			
1	SPEED	17	NONE
2	FAN1	18	NONE
3	FAN2	19	NONE
4	WORK	20	NONE
5	NONE	21	NONE
6	NONE	22	NONE
7	NONE	23	NONE
8	NONE	24	NONE
9	LOW BIN 1	25	NONE
10	METER 1	26	NONE
11	LOW BIN 2	27	NONE
12	METER 2	28	NONE
13	LOW BIN 3	29	NONE
14	METER 3	30	NONE
15	LOW BIN 4	31	NONE
16	METER 4	32	NONE

Note

Channel assignments for Sensor Assignments and Sensor Diagnostics are shown in the table on the next page.

Setting Sensor Logic

On the Sensor Logic page you can configure the logic of each sensor channel. Logic is the expected output when the sensor is activated. For example, logic determines whether an action is initiated when a switch closes or when it opens. This page enables you to invert the logic (action) of any sensor. Sensor logic is preset from the factory, but if you add a sensor for some purpose, you may have to configure its logic.

To configure sensor logic for a channel:

1. Press the Sensor Logic soft key.



The Sensor Logic Type page appears.

2. Select the number of the sensor channel to be configured.
3. Select the appropriate sensor logic for the desired channel.

SENSOR LOGIC TYPE			
1	NORMAL	17	NORMAL
2	NORMAL	18	NORMAL
3	NORMAL	19	NORMAL
4	NORMAL	20	NORMAL
5	NORMAL	21	NORMAL
6	NORMAL	22	NORMAL
7	NORMAL	23	NORMAL
8	NORMAL	24	NORMAL
9	NORMAL	25	NORMAL
10	NORMAL	26	NORMAL
11	NORMAL	27	NORMAL
12	NORMAL	28	NORMAL
13	NORMAL	29	NORMAL
14	NORMAL	30	NORMAL
15	NORMAL	31	NORMAL
16	NORMAL	32	NORMAL

Note

Amity meter box flow sensors use inverted logic. This is the default setting and should not need to be changed.

Sensor Assignment and Diagnostics Reference Channel Map

Channel Number	Sensor Assignment	Diagnostic Reference
1	Speed	Speed
2	Fan 1	Fan 1
3	Fan2	Fan2
4	Automatic Master Work Switch	Automatic Master Work Switch
5		
6		
7		
8		
9	Low Bin 1	
10	Meter 1	
11	Low Bin 2	
12	Meter 2	
13	Low Bin 3	
14	Meter 3	
15	Low Bin 4	
16	Meter 4	
17		Low Bin 1
18		Meter 1
19		Low Bin 2
20		Meter 2
21		Low Bin 3
22		Meter 3
23		Low Bin 4
24		Meter 4
25		
26		
27		
28		
29		
30		
31		
32		

Setting Up Automatic and Manual Master Work Switch Operation

To set up Manual Master Work Switch operation:

1. On the Calibration page, press the Sensor Assignment soft key.



The Sensor Types page appears.

2. Select sensor **4**.
3. Change its setting to **None**.
4. Press the System Settings soft key and then the Home soft key to return to the Home page.

To set up Automatic Master Work Switch operation:

1. On the Calibration page, press the Sensor Assignment soft key.



The Sensor Types page appears.

2. Select sensor **4**.
3. Change its setting to **Work**
4. Verify the sensor logic is correct.
5. Press the System Settings soft key and then the Home soft key to return to the Home page.
6. Raise the planting system.
7. On the Home page, press the Master Work Switch soft key .



8. Verify that the Master Work Switch soft key indicates On.
(If not, press the soft key again until it indicates On.)
9. Start moving forward in the field with the tractor and planting system.
10. Lower the planting system.
11. On the Home page, verify that the meters are indicating motor RPM and the Actual Rates indications show that the meters and NH3 system are delivering product.

SENSOR TYPES			
1	SPEED	17	NONE
2	FAN1	18	NONE
3	FAN2	19	NONE
4	WORK	20	NONE
5	NONE	21	NONE
6	NONE	22	NONE
7	NONE	23	NONE
8	NONE	24	NONE
9	LOW BIN 1	25	NONE
10	METER 1	26	NONE
11	LOW BIN 2	27	NONE
12	METER 2	28	NONE
13	LOW BIN 3	29	NONE
14	METER 3	30	NONE
15	LOW BIN 4	31	NONE
16	METER 4	32	NONE

Note

You can still use the Master Work Switch soft key on the Home page to turn the machine off in Automatic mode.

Note

The logic of the Automatic Master Work Switch can be inverted (on the Sensor Logic page) in order to match how the magnetic sensor on the machine is configured. If the logic is normal, the D3 will indicate the implement is Down when sensor detects the magnet. If the logic is inverted, the D3 will indicate the implement is Up when the sensor detects the magnet.

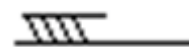

Implement Down

Implement Up

Note

When the system is configured for for automatic Master Work Switch operation, lifting the machine automatically turns off the meter drives and NH3 system. Lowering the machine automatically turns on the meter drives and NH3 system. The manual Master Work Switch must be on for the automatic Master Work Switch to work. The manual Master Work Switch can override the automatic Master Work Switch to turn the system off. The manual Master Work Switch cannot override the automatic Master Work Switch to turn the system on.

Storing User Calibration Values and Settings

When you have completed setting up and calibrating the system you should store all your settings and calibration values. This will ensure that you can restore your settings if a power glitch or other event causes them to be lost. You store and restore settings and calibration values on the Default page.

To store settings and calibration values:

1. On the Calibration (System Settings) page, press the Calibration Storage soft key.



The Default page appears.

2. Press the **STORE USER CAL** soft key.
The system stores your user calibration settings.
3. Press the System Settings (Cal) soft key and then press the Home soft key to return to the Home page

You can now shut down the system and your settings will remain in memory.



Restoring User Calibration Values and Settings

To restore previously stored settings and calibration values:

1. On the Calibration (Systems Settings) page, press the Calibration Storage soft key.



The Default page appears.

2. Press the **RESTORE USER CAL** soft key once.
The system restores your user calibration settings from memory.
3. Press the System Settings soft key and then press the Home soft key to return to the Home page.
4. On the Home page, check the information displayed to verify that the correct information has been restored.
5. Check the System Settings and Sensor Assignment pages to verify that the correct information has been restored.

Restoring Default Calibration Values and Settings

If the system settings, sensors and setup has been totally changed, you can return to factory default settings using the following procedure.

1. On the Calibration (Systems Settings) page, press the Calibration Storage soft key.



The Default page appears.

2. Press the **Calibration Storage** soft key again.



3. Press the System Settings soft key and then press the Home soft key to return to the Home page.
4. On the Home page, check the information displayed to verify that the default setting has been restored.
5. Check the System Settings and Sensor Assignment pages to verify that the default settings have been restored.
6. Set up all your operating parameters and re-calibrate your system.



Warning

If you use the Default Cal soft key to restore the factory default settings you will have to redo the whole System Setup procedure.

D3 ISO MONITOR - DIAGNOSTICS AND TROUBLESHOOTING

This section provides information on how to test and troubleshoot various parts of your air cart system. For additional help with testing and troubleshooting contact your Amity dealer.

Sensor Diagnostics

The Sensor Diagnostic page provides information about the operational state of the system sensors. It is most commonly used by service personnel for testing, but you can also use it to test the sensor operation. Typically you would change the state of a sensor (e.g. block a bin sensor), press the Refresh key, and check the State or Pulses indication for that sensor on the Sensor Diagnostic page. Bin sensors indicate a change of State after the Refresh soft key is pressed. Fan and sensors will show an accumulation of pulses after the Refresh soft key is pressed.

To view sensor diagnostic information:

1. On the Calibration page, press the Sensor Assignment soft key.



The Sensor Types page appears.

2. Press the Sensor Diagnostic soft key.



The Sensor Diagnostics page appears and displays information about the first four (4) sensors in the sensor list.

3. If necessary to view a particular sensor, press the **Next 4** soft key once or more to advance to the page showing the desired sensor information.



4. Press the **Refresh** soft key to update the information for each sensor displayed.



5. Note the State and Pulses values for the sensors you are interested in.
6. Change the state of the sensor (block bin sensors or run fan or shafts).
7. Press the **Refresh** soft key to update the information.
8. Note the State and Pulses values and compare them with the previous values to determine if they are operating correctly.

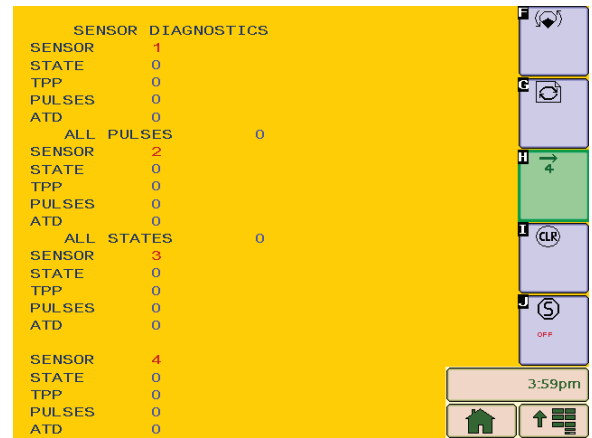

Note

Refer to the Sensor Assignments and Diagnostics Reference table in the D3 ISO Monitor - Other Settings section for sensor diagnostic channel assignments.

Information shown on the Diagnostics Page:

State: The state of the sensor (on or off) when the Refresh soft key was pressed.

Pulses: The number of time the sensor has changed states since the last time the Refresh soft key was pressed.

TPP: The time between pulses. Typically only used only by technical service personnel.

ATD: Analog to digital. Typically only used by technical service personnel.

Turning Sensors On and Off

You can turn sensors on and off to facilitate various troubleshooting procedures.

To turn sensors on or off:

1. On the Calibration page, press the Sensor Assignment soft key.



The Sensor Types page appears.

2. Select the desired sensor number and:
 - a. Select **None** to turn off the sensor.
 - b. Select the sensor name to turn on the sensor.

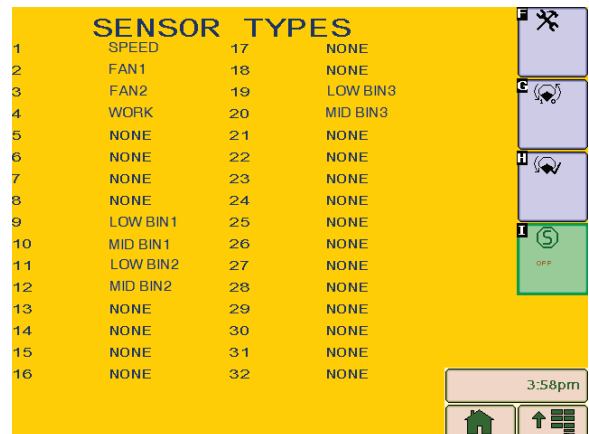

Note

Refer to the Sensor Assignments and Diagnostics Reference table in the D3 ISO Monitor - Other Settings section for sensor channel assignments.

Using Test Speed to Simulate Forward Motion

The Test Speed function on the ISOBUS system enables you to simulate forward motion of your implement. This allows you to perform diagnostics while not in motion. You can set the monitor to simulate a specific forward speed.

To set the Test Speed value:

1. On the Calibration page, select **Test Speed**.
2. Enter the desired test speed in miles per hour (mph)
3. Verify that the correct Test Speed value is displayed on the Calibration page
4. On the appropriate pages, turn on or off the functions to be tested (motors, sensors, NH3, etc.)

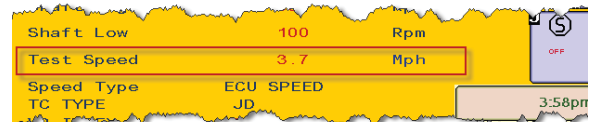

Sensor Troubleshooting: Common Problems and Solutions

Symptom	What it means	Recommended Action
Ground/meter speed sensor not picking up speed or the speed reading is erratic	Improper Sensor Range Adjustment	The recommended gap setting is 1/16" (.063") from the face of the sensor to the tip of the sprocket teeth. If the gap is out of range, adjust to bring back within specifications.
	Missing or Damaged Target	Replace the target sprocket if it is missing or if the teeth have been damaged. Ensure the sprocket is in proper alignment with the sensor.
	Sensor Physically Damaged by Target	If the sensor was adjusted too close to the target, it will be hit and damaged. Replace the damaged sensor and check for proper range adjustment.
	Damaged Sensor Mount	The sensor mounting bracket holds the sensor in place so that the sensor is at the proper location and spacing from the sprocket teeth. Replace or Repair the sensor mount if it is damaged and/or if the sensor barrel does not line up with the targets.
	Defective Sensor	When the sensor is powered, the red light on the sensor will be on. The light will remain solid-on during operation. If the light is not on or if the light is on and the ground speed reading remains at "0" when the cart is moving, check the wiring. If the wiring is good, replace the sensor.
	Defective Wiring	Use a jumper wire to intermittently jump across the Signal and Ground wires (Pins 2 & 3, Orange & Blue) in the main harness to simulate the sensor in operation. If "0" speed is still shown on the display while simulating, the sensor's signal is not getting back to the ECU and there is a bad/loose connection or a problem with the wiring. Perform steps to diagnose the harness.
	Improper Sensor Range Adjustment	The face of the sensor should be between 2mm and 4mm away from the target. If out of range, adjust to bring back within specifications.
Fan speed sensor not picking up speed or the speed reading is erratic	Sensor Physically Damaged by Target	If the sensor was adjusted too close to the target, it will get hit and damaged. Replace the damaged sensor.
	Defective Sensor	When the sensor is powered, the red light on the sensor will be on. When the sensor senses the target, the red light will go off until the target leaves the range of the sensor. Replace sensor if defective.
	Defective Wiring	Use a jumper wire to intermittently jump across the Signal and Ground wires (Pins 2 & 3, Pink & Blue) in the main harness to simulate the sensor working. If "0" speed is still shown on the display while simulating, the display head is not reading the sensor and there is a problem with the wiring. Perform steps to diagnose the wire harness.
	Missing or Defective Target	Two 3/8" x 1/2" UNC bolts are fastened to the fan rotor and are used as targets for the speed pickup. Lock washers are used under the bolt head. Replace any missing or damaged bolts/washers.
	Damaged Sensor Mount	The sensor mounting bracket holds the sensor in place so that the sensor is at the proper location and spacing from the two bolts (targets) on the fan rotor. Replace or Repair the sensor mount if it is damaged and/or if the sensor barrel does not line up with the targets.

Symptom	What it means	Recommended Action
Meter-Box Proximity Sensor Not Operating Correctly	Meter Empty	If the meter-empty alarm is active, check the meter to ensure the meter is empty before performing further troubleshooting.
	Sensor Face Dirty	If the face of the sensor has foreign material or product stuck to it, the sensor will give a false reading. Remove foreign material from the face of the sensor.
	Sensor Sensitivity out of Adjustment	The light on the end of this sensor should be OFF when the meter box is empty and ON when the meter box is full of product. To properly adjust the sensitivity, empty the meter box (need to close the gate & pull the doors off), and ensure the face of the sensor is clean. Put the door back on and open the seed gate to allow product back into the meter box. With the meter box full of product, perform the following sensor adjustment: <ul style="list-style-type: none"> o Find the calibration screw on the rear of the sensor (next to the yellow light). Turn the screw counter-clockwise until the light turns off. If the light is already off, go to the next step. o Turn the screw clockwise until the light just turns back on. Then turn the screw 2 more full turns in the clockwise direction.
Low-Bin Level Sensor Not Operating Correctly	Defective Sensor	Test the sensor by placing an object in-front of the sensor face. The LED light on the sensor should light up when the object is present. The LED light should be off when there is nothing in front of the sensor. The sensor needs to be connected to the harness and the monitor needs to be turned on to perform this test. Replace sensor if defective.
	Defective Wiring	Use a jumper wire to jump across the Signal and Ground wires (Pins 2 & 3, Violet & Blue) in the main harness to simulate a full meter. The Low-Meter alarm should activate when the sensor is unhooked and the alarm should be off when the jump-wire is used. If these alarm conditions are not observed, begin troubleshooting the wire harness.
	Bin Empty	If the low-bin alarm is active, check the bin to ensure the seed level is below the sensor before performing further troubleshooting.
	Defective Sensor	Test the sensor by blocking the path between the two sensor eyes. When the path is open, the low-bin alarm should be active. When the path is blocked, the low-bin alarm should be off. Replace sensor if defective.
	Improper Sensor Mounting	Ensure the sensor is mounted in a position where product cannot collect on the sensor.
	Sensor Beam Too Strong	If the bin alarm is going off when there is still product in the tank, the infrared sensor beam may be too strong. This can be corrected by using a hand file and shaving 1mm off of each sensor eye.
	Defective Wiring	Use a jumper wire to jump across the Signal and Ground wires (Pins 2 & 3, Tan & Blue) in the main harness to simulate a low-bin level condition. If the bin alarm does not activate, begin troubleshooting the wire harness.

ART SYSTEM - DIAGNOSTICS AND TROUBLESHOOTING

ART Troubleshooting: Common Problems and Solutions

In the following error messages an underscore _ indicates a number will appear in this spot to indicate a loop, sensor or other number.

Symptom	What it means	Recommended Action
Monitor displays Loop _ LOOP OFF	The loop indicated is turned off.	To turn loop on, increase sensitivity >1
Monitor displays Loop _ RESET	The loop indicated is resetting.	
Monitor displays Loop _ COUNTING Sensor _	The loop indicated has counted the number of sensors indicated	
Monitor displays Loop _ BLOCKED Sen- sor _	The sensor indicated is blocked.	Clean blockage from indicated run.
	If the indicated run is not blocked...	...verify the Sensitivity is not set too high. Check inside the distribution towers for any foreign material. This may cause blockages to move from sensor to sensor.
	If it is always the same sensor giving the blocked message...	...trade that sensor with one in another position.
	If the blocked message moves with the sensor...	...replace that sensor.
Monitor displays Loop _ ERROR Sensor 1	The monitor is not detecting any sensors.	Check all the cables and connections. Bypass Sensor 1 by connecting Sensor 2 to the sensor loop cable from the main wiring harness.
	If the message is no longer displayed...	...replace Sensor 1.
	If the problem persists...	...connect a Seed Sensor directly to the main wiring harness' male Sensor Loop Cable.
	If you get a SNR 2 ERR...	...replace the Sensor Loop extension cable between the Main wiring harness and Seed Sensor 1
Monitor displays ERROR Sensor_ (in- dicating a number one higher than total number of sensors)	The monitor is reading an incorrect number of sensors.	Check all the cables and connections. Bypass the last sensor by connecting the second last sensor to the sensor loop cable to the main wiring harness.
	If the message is no longer displayed...	...replace the last sensor in the loop.
	If the problem persists...	...connect a Seed Sensor directly to the main wiring harness.
	If you get an SNR 2 ERR...	...replace the main wiring harness.
	If you get an SNR 1 ERR...	...replace the Sensor Loop extension cable between the main wiring harness and the last Seed Sensor.

Symptom	What it means	Recommended Action
Monitor Displays Loop __ ERROR Sensor __	The monitor is detecting an error related to a specific sensor.	Take note of the Sensor number indicated. Inspect the Sensor Loop cables in the indicated Seed Sensor location for damage. Replace or bypass any damaged pieces.
		Bypass the indicated seed sensor number by unplugging the seed sensor and plugging the cables of the seed Sensor before and after together. (The Seed Sensor count will be one less.)
	If this results in normal operation...	...replace the bypassed sensor.
	If the ERR message is still displayed...	...bypass the Seed Sensor before the indicated Seed sensor number.
	If this results in normal operation...	...replace the bypassed sensor.
	If a Sensor Loop cable connects the two Seed Sensors...	...swap out the Sensor Loop cable with a known good one.
	If this results in normal operation...	...permanently replace the original Sensor Loop cable.
Blocked runs are indicated but when checked and found to be clear.	The monitor is receiving incorrect blockage information.	Verify that the Sensitivity is not set too high. Check inside the distribution towers for any foreign material. This may cause blockages to move from sensor to sensor.
	If it is always the same sensor giving the blocked message...	...trade that sensor with one in another position.
	If the blocked message moves with the sensor...	...replace that sensor.
Monitor displays Loop __ CLEAN Sensor__	This message indicates that the eyes (optical detectors) in the Seed Sensor tube are dirty.	Take note of the indicated numbers. Clean the indicated Seed Sensors with warm water and a bristle pipe brush.
	If the Seed Sensor still causes a CLN message...	...replace it.
Monitor displays Loop __ OVERLOAD	This message indicates that there is too large a power draw on the indicated sensor loop. There is most likely a short in the Sensor Loop.	Check all the cables and connections.

Symptom	What it means	Recommended Action
Calibration settings are lost.	The memory in the monitor that contains calibration settings has been erased.	<p>Ensure that the monitor is connected directly to the battery.</p> <p>Check the voltage between the red and black wires of the power cable. Voltage should be greater than 10V.</p> <p>Check the tractor's battery cables, connection to the starter and alternator. Electrical surges due to a faulty electrical system can cause this problem.</p> <p>Check that the red wire is not connected to the starting solenoid terminal.</p>
Monitor displays ERROR alarms when one loop is disabled, but no alarms when both loops enabled.	Typically this means that loops are all connected but cables are crossed either going to sensor 1 or coming back from the last sensor.	<p>Trace sensor cables from the main wiring harness to the first and last sensor of one loop.</p> <p>Re-connect the cables correctly.</p>

D3030 VT - INSTALLATION AND OPERATION

Installing the D3030 ISO VT

If your tractor is not equipped with a virtual terminal and associated wiring, you can install an Amity D3030 ISO Virtual Terminal to interface with your air cart monitoring system.

D3030 VTs communicate on the ISO11783 backbone to control and monitor your air cart ECU and the ART seed monitoring system. It can also interface with some other ECUs and control products.

Use the following procedure to install the D3030 VT, ISOBUX connector, generic tractor wiring harness, and VT adaptor cable. (These items are available as a kit from your Amity dealer.)

Mounting the D3030 Virtual Terminal

The D3030 VT comes from the factory with a hook and loop strip attached to the back of its enclosure. To mount the D3030 simply remove the cover from the adhesive on the hook and loop strip and press the adhesive to a clean, flat surface.

Note

If you are not using a D3030 VT, skip this section and consult the manual that came with your VT for operating instructions.



Installing the ISOBUX Connector

1. Mount the ISOBUX connector in a suitable location near your tractor hitch.

Pin	Conductor	Signal
1	8AWG Black	Battery Ground
2	16AWG Black	ECU Ground
3	8AWG Red	Battery 12V Power
4	16AWG White	ECU 12V Power

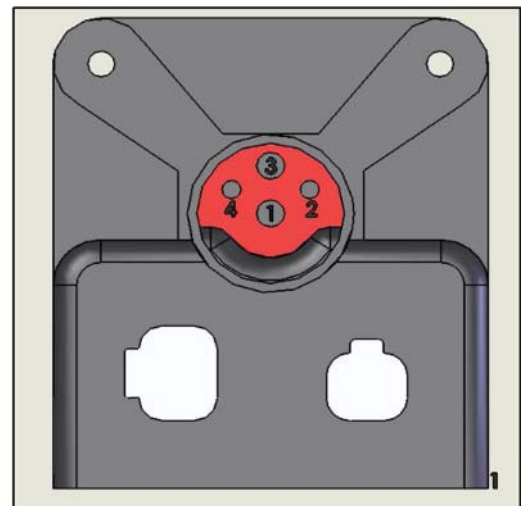

REAR VIEW

Installing the Generic Tractor Wiring Harness

2. Route the generic tractor wiring harness from the hitch to the battery and the location where you will mount your virtual terminal.

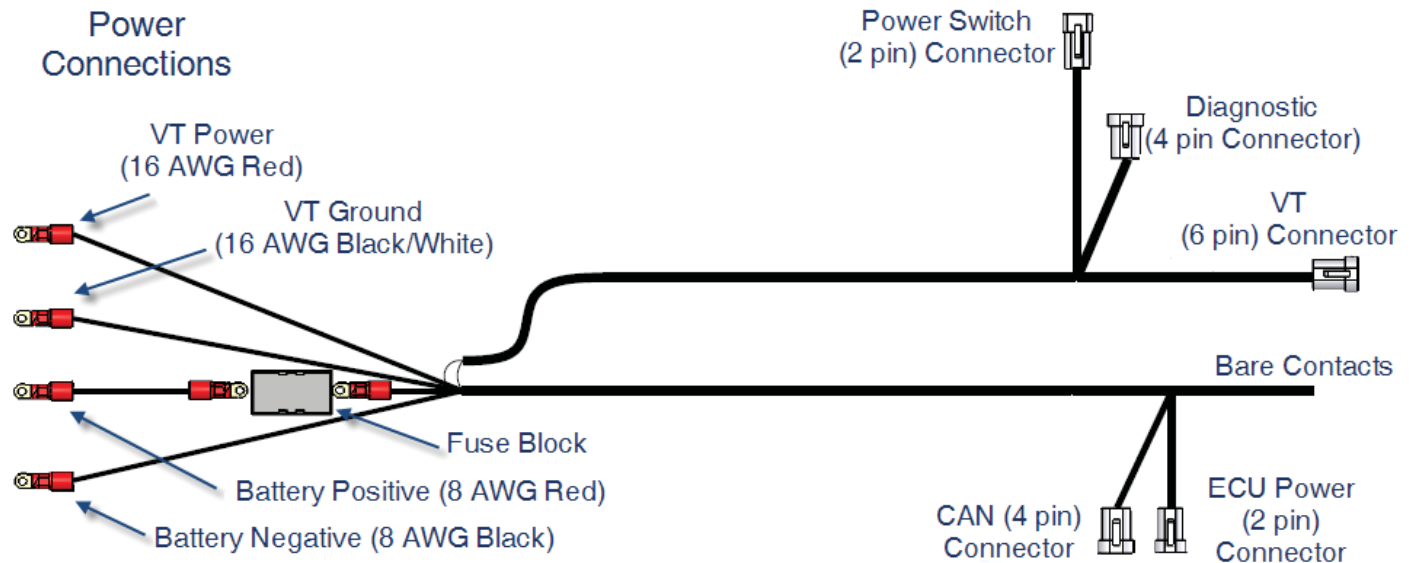

3. At the rear of the tractor, remove the backshell cover on the ISOBOX connector.
4. Plug the bare contacts on the tractor harness into the back of the ISOBOX 4-pin connector using the table and connector diagram shown on the previous page as a reference.
5. Re-install the backshell cover on the ISOBOX connector.
6. Fit the CAN (2-pin) and ECU Power (4-pin) connectors on the tractor harness into the appropriate cutouts in the ISOBOX.
7. At the tractor battery, connect the red 16AWG and 8AWG power wires from the tractor harness to the positive terminal on the battery.
8. Connect the the 16AWG black/white and 8AWG black wires from the tractor harness to the negative terminal on the battery.
9. At the ISOBOX connector, use a meter or voltage test probe to verify that terminals 3 and 4 are connected to 12 volt power and that terminals 1 and 2 are connected to ground (0 volts).



Caution

Double-check the pin locations before inserting each contact/wire. Removing the contacts is possible but a special tool from Deutsch is required for each contact size.



Caution

Do not connect the D3030 VT to the wiring harness before verifying that the power connections are correct.

Connecting the VT Adaptor Cable

10. Route the VT adaptor cable (P/N 34815) from the 6-pin VT connector on the tractor harness to the location in the tractor cab where you will mount the VT.
11. Plug the 6-pin VT connector on the tractor harness into the matching connector on the VT adaptor cable.

Connecting the D3030 VT

Harness (6 pin) Connector



DB9 Plug



12. Plug the DB-9 (9-pin) connector on the VT adaptor cable into the right-hand chassis connector on the bottom of the D3030 VT.



LH connector

- Remote Work Switch port









RH connector

- Tractor harness connection port

Operating the D3030 VT

D3030 Features and Controls

The D3030 features eight navigation keys (including four keys that can be re-purposed as actuator switches and four arrow keys), and ten soft keys.

Button	Function
	Press to turn power on and off Press to operate AUX1 (Can be configured to switch Product 1 On and Off)
	Press to exit the edit screen without saving changes Press to operate AUX2 (Can be configured to switch Product 2 On and Off)
	Press to accept and save changes and exit the edit screen Press to operate AUX3 (Can be configured to switch Product 3 On and Off)
	Press to move to a new calibration mode Press to operate AUX4 Press to acknowledge an alarm (Can be configured to switch Product 4 On and Off)
	Press to cycle through the selectable objects from bottom to top
	Press to cycle through the selectable objects from top to bottom
	Press to return to the main screen Press to backspace in editing mode
	Press to initiate editing of the currently selected object Press to enter a decimal in editing mode







Monitor Control Page

When the VT is first powered on the Monitor Control page appears. You can return to this page from on any other page by pressing the HOME SCR N () key.

To navigate from this page to other pages, you use the soft keys located on both sides of the display. The icon displayed on the screen, adjacent to each arrow button represents the function assigned to that button.

There are several soft keys that are used to access internal functions of the VT. These include the following:

-  Calibration page
-  Pool Information page
-  Task Controller page
-  Auxiliary Control page

All ISOBUS-compatible electronic control units (ECU) connected to the system (e.g. tractor ECU, sprayer ECU, air cart ECU, etc)

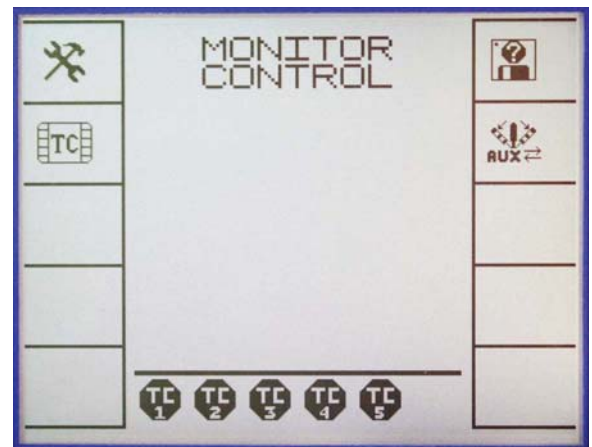

Note

The process of loading an information pool for each ECU connected to the D3030 can take a few minutes to complete after power up. Be patient for the soft key icons to appear on the VT screen.

communicate with the VT. Each ECU identifies itself and causes the VT to display a soft key icon adjacent to a button. Pool information refers to the information packets sent between the ECU and VT. Each ECU sends a "pool" of information to the VT to tell it what the ECU does and information it needs.

To open the main control screen of any control unit connected to the ISOBUS, press the button adjacent to its soft key icon.

Monitor Cal Page

The Monitor Cal (Calibration) page is used to configure the user settings for the D3030 VT.







Settings that are user definable include:

- **Units** - SAE or Metric
- **Map Port** - On or Off
- **USB Port** - On or Off
- **Volume** - 0.0 to 10.0 in 0.1 increments

Settings that are displayed only include:

- **Run Time** - Indicates the elapsed time (in hours.min) that the VT has been on
- **ECU Amps** - Indicates the electric current supplied by the ECU power driver
- **RAM status** - Indicates the status fo the external RAM memory

Soft keys used for internal VT functions include:

-  RAM test - result displayed by RAM status
-  Clear the Run Time Clock
-  Diagnostics for the LCD display
-  Diagnostics for the monitor keys
-  Diagnostics for the RS232 port
-  Reset user settings to default values
-

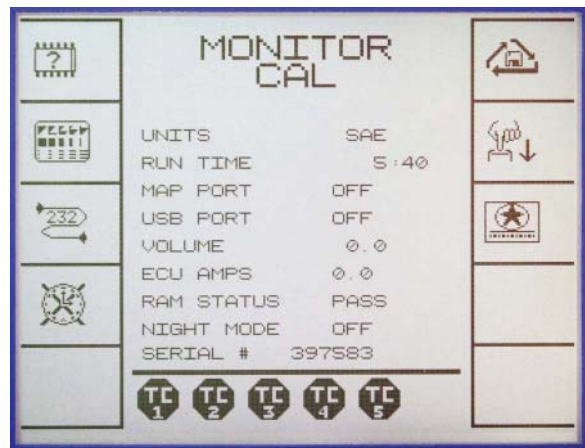



Pool Information Page

Settings that are displayed only include:

- **Pool Memory** - amount of memory used for current pool storage
- **Pool Objects** - count of all objects currently in the memory
- **VT Objects** - count of objects required by the VT to operate
- **Task Memory** - memory used for current task pool storage
- **TP Progress** - transfer protocol progress
- **ETP Progress** - extended transfer protocol progress

The soft keys for internal VT functions are:

-  Delete all workset pools
-  Delete all task pools
-  Pool diagnostic screen

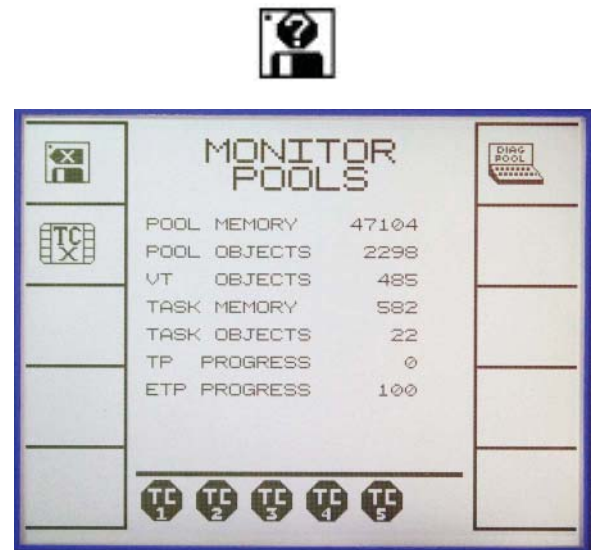

Task Control Page

The Task Controller page is used to configure the task controller (virtual terminal). Using the Task Controller page, you can configure communications between a mapping computer and the D3030 VT. (To implement this function you must be using a Raven Viper controller and the mapping computer must use Raven 760 control strings and Farm Works software.)

To set up the Task Controller:

1. Connect the mapping computer to the D3030 via the left D-Sub connector.
2. To enable communication, set Map Port to ON in the calibration screen.
3. The mapping computer must be set to use the following comm. settings:
 - 19,200 baud
 - 1 stop bit
 - No Parity
 - No Flow control
4. Settings on the Task Controller Screen that are user definable are:
 - Rate 1 - Variable rate product selection
 - Rate 2 - Variable rate product selection
 - Rate 3 - Variable rate product selection
 - Rate 4 - Variable rate product selection
 - Rate 5 - Variable rate product selection



Auxiliary Controller Page







The Auxiliary Controller page is used to configure the Auxiliary Controller. Using the Auxiliary Controller, an ISO input can control an ISO function.

Settings that are displayed only include:

- Aux Link - identifying number of link
- Switch Type - identifying type of switch

The page displays symbols for input controls and control functions with their workset addresses shown immediately below them.

The soft keys for internal VT functions include:

-  Cycle to the previous link configuration
-  Cycle to the next link configuration
-  Cycle to the previous input control
-  Cycle to the next input control
-  Cycle to the previous control function
-  Cycle to the next control function
-  Save the current configuration to the current link number

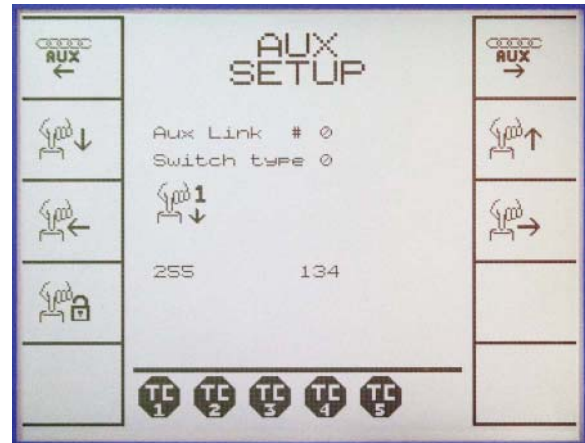

AIR SYSTEM ASSEMBLY PARTS

PARTS TABLE OF CONTENTS

PartsTable of Contents	76
Assy-Tank/Running Gear.....	78
Assy-Airstream Single	79
Assy-ECU	80
Assy-Pressurization Kit	82
Assy-Axles Front.....	83
Assy-Drawpole & Steering Linkage.....	84
Assy-Axles Rear	86
Assy-Tie Rod.....	87
Assy-Hub 65450 & 1017759	87
Assy-Meter Driveline	88
Assy-W&T 18.4x26 R1 8Ply, 16x26x8.....	90
Assy-W&T 23.1x26 R1 10Ply, 20x26x8.....	90
Kit-Calibration Components.....	91
Assy-Meterbox.....	92
Assy-Meterbox Door	94
Assy-Blower.....	96
Assy-Blower Hydraulics Ground Drive	98
Assy-Ground Drive.....	100
Assy-Blower Hydraulics Variable Rate Drive.....	102
Assy-Variable Rate Drive	104
Assy-Catwalk & Handrails	106
Assy-Ladder Air System	107
Assy-Auger & Hydraulics (8"/10").....	108
Assy-Auger Mounting Components (8"/10")	110
Virtual Terminal Cab Kit	111
ISO Blockage/Work Switch Harness Kit.....	112
Assy-Doors	113
Assy-Decals Airs System	114

This Page
Left
Intentionally
Blank

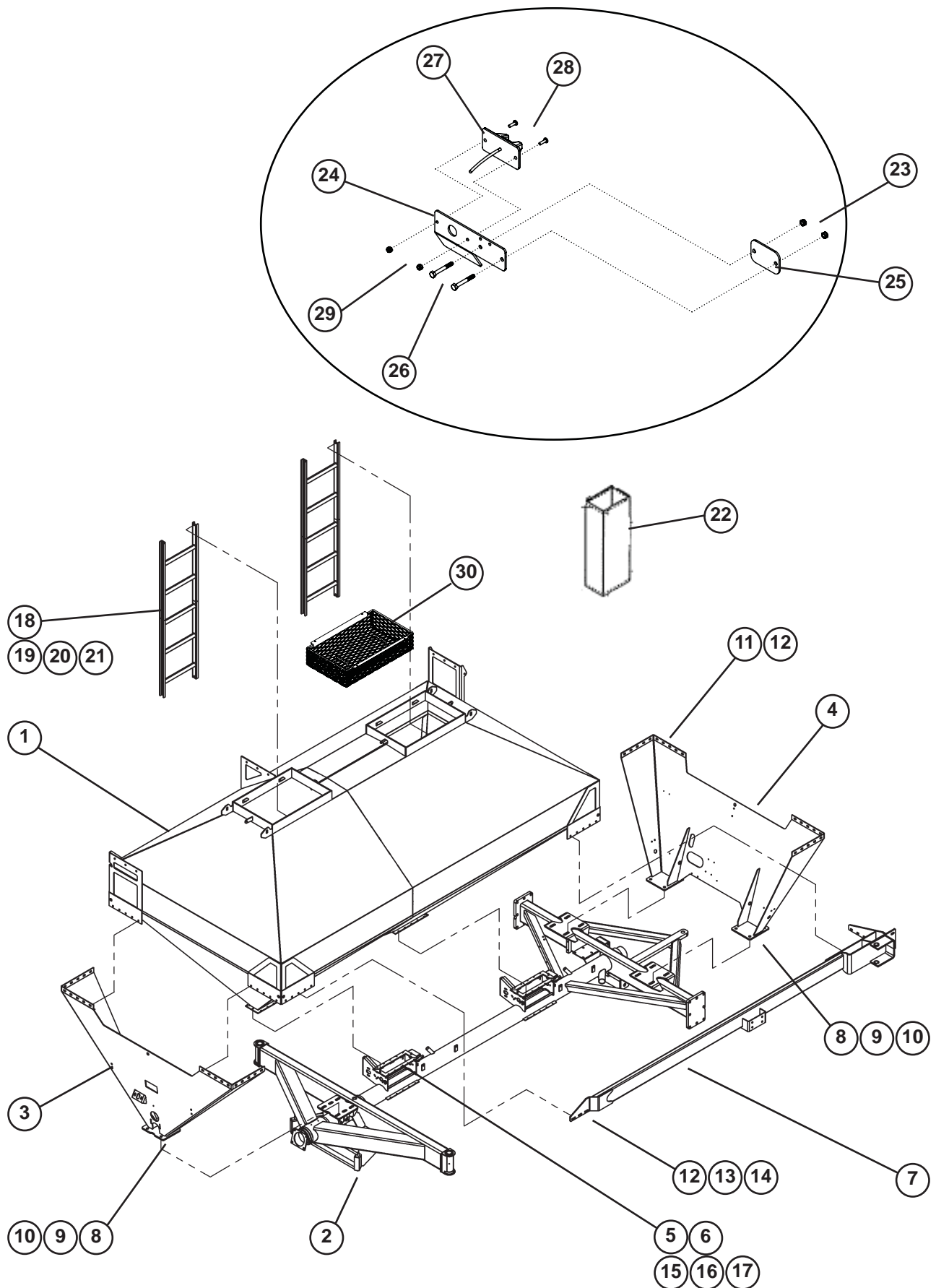

ASSY-TANK/RUNNING GEAR

Ref.	Part No.	Description	Qty.
1	65402	WLDMT-TANK 2800	1
	65938	WLDMT-TANK 3350	1
2	65406	WLDMT-RUNNING GEAR	1
3	65525	WLDMT-FRONT PANEL	1
4	65526	WLDMT-REAR PANEL	1
5	65512	GASKET-SEEDBOX .250	2
6	64504	SEALANT-PROGLAZE - OZ.	90
7	65816	WLDMT-AUGER MOUNT	1
8	1012060	BOLT-HEX: .75 X 2.00 NC GR5 ZP	14
9	1017000	NUT-TOPLOCK: .75 NC GR5 ZP	14
10	1030702	WASHER-FLAT: .75 ZP	14
11	1011606	BOLT-HEX: .50 X 1.25 NC GR5 ZP	29
12	1011608	BOLT-HEX: .50 X 1.75 NC GR5 ZP	11
13	1027461	NUT-TOPLOCK: .50 NC GR5 ZP	40
14	1011584	WASHER-FLAT: SAE .50 ZP	51
15	66043	BOLT-CRG: SS .250 X 1.25 NC	20
16	65695	WASHER-FLAT: .250 SS	20
17	1033269	NUT-NYLOCK: .25 NC GR2 SS	20
18	65678	WLDMT-LADDER INSIDE 2800	2
	65942	WLDMT-LADDER INSIDE 3350	2
19	1033271	BOLT-HEX: SS .38 X 1.00 NC	4
20	1033268	NUT-NYLOCK: .38 NC GR2 SS	4
21	65778	WASHER-FLAT: .375 SS	8
22	66549	KIT-LOW VOLUME TANK INSERT 2800 (OPTIONAL)	
	66550	KIT-LOW VOLUME TANK INSERT 3350 (OPTIONAL)	
23	1033269	NUT-NYLOCK: .25 NC GR2	2
24	65836	MOUNT-BIN LEVEL SENSOR	1
25	65837	PLATE-BOLTING	1
26	65838	BOLT-HEX: SS .25 X 2.00 NC GR5	2
27	66509	BIN LEVEL SENSOR	1
28	65839	SCREW-P-H: #10 X .75 NC SS	2
29	65712	NUT-NYLOCK: #10-24 SS	2
30	1026562	SCREEN BASKET (OPTIONAL)	2

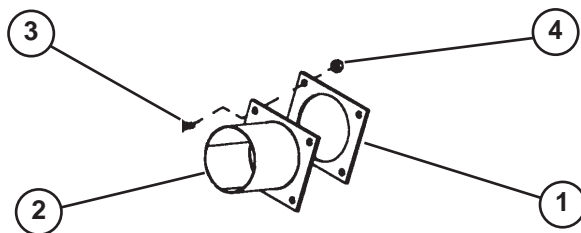

ASSY-AIRSTREAM SINGLE

Ref.	Part No.	Description	Qty.
1	1023159	GASKET .13 X 5.75 X 7-5" ID	1
2	65443	WLDMT-FLANGE & TUBE	1
3	1011606	BOLT-HEX: .50 X 1.25 NC GR5 ZP	4
4	65313	NUT-NYLOCK: .50 NC GR2 ZP	4

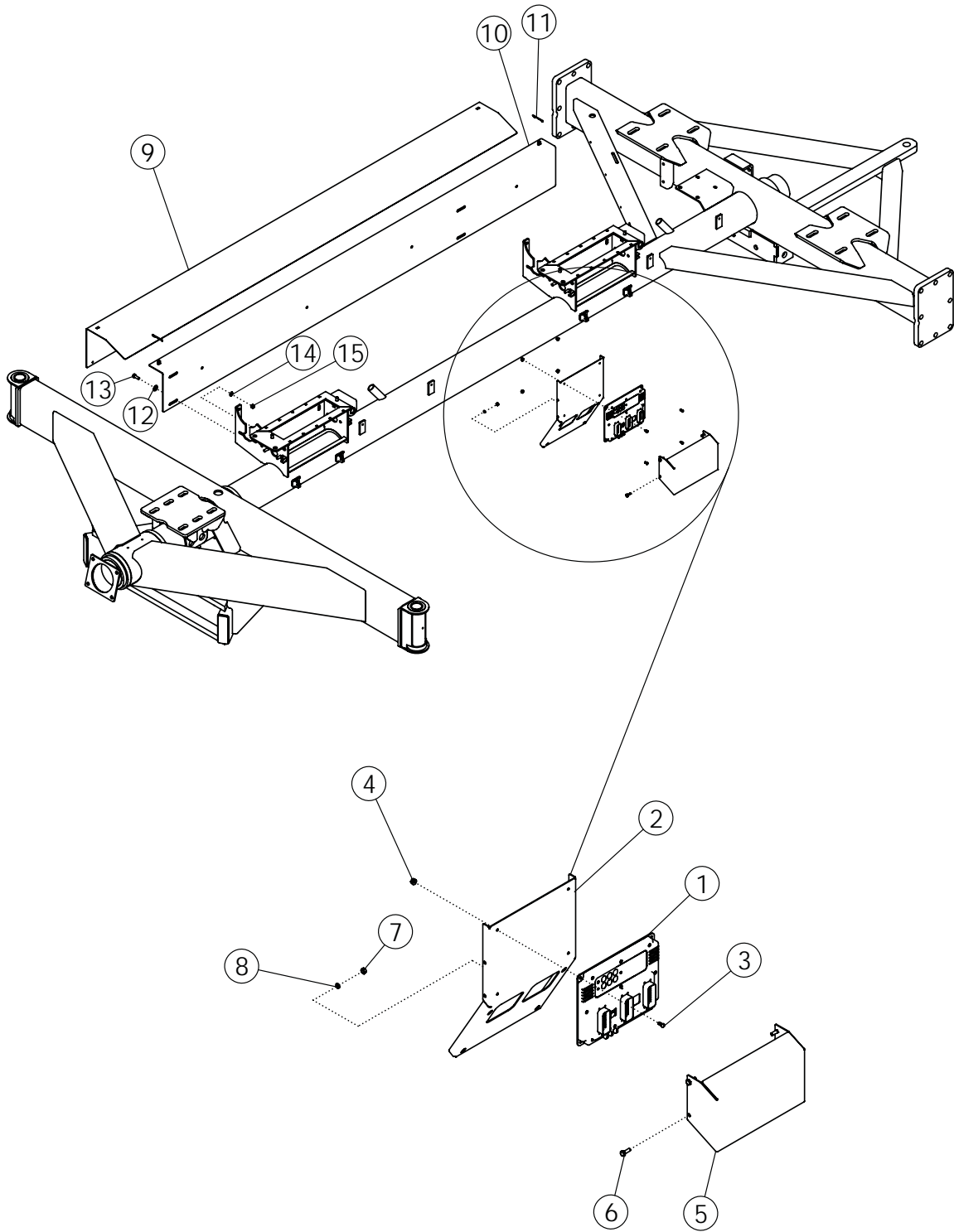

ASSY-ECU MOUNT

Ref.	Part No.	Description	Qty.
1	67085	ECU-D3 ISO CONTROLLER	1
2	67219	PLATE-ECU MOUNT	1
3	1013462	SCREW	4
4	1026591	NUT-K-LOCK: .19 NC GR2 ZP	4
5	67249	COVER-ECU MOUNT	1
6	1011595	BOLT-HEX: .25 X .75 NC GR5 ZP	4
7	1011587	NUT-HEX: .25 NC GR5 ZP	4
8	1013242	WASHER-LOCK: .25 ZP	4
9	65452	COVER-HOSE MOUNT	1
10	66006	WLDMT-SHIELD BOX	1
11	1012901	PIN-HAIR: .13 X 2.50 ZP	2
12	1011828	WASHER-FLAT .38 ZP	2
13	1011600	BOLT-HEX: .38 X 1.00 NC GR5 ZP	2
14	1011586	WASHER-LOCK: .38 ZP	2
15	1011576	NUT-HEX: .38 NC GR2 ZP	2
16	67088	TANK HARNESS (NOT SHOWN)	1
17	67492	HARNESS-TANK COMPONENT SHORT (NOT SHOWN)	2
18	67514	1/4" WIRE MOUNT (NOT SHOWN)	4
19	67515	3/8" WIRE MOUNT WITH INSERT (NOT SHOWN)	1
20	66585	WIRE HARNESS PURSE LOCK WHITE CLIP (NOT SHOWN)	11
21	67519	TERMINATING SEAL PLUG (NOT SHOWN)	1

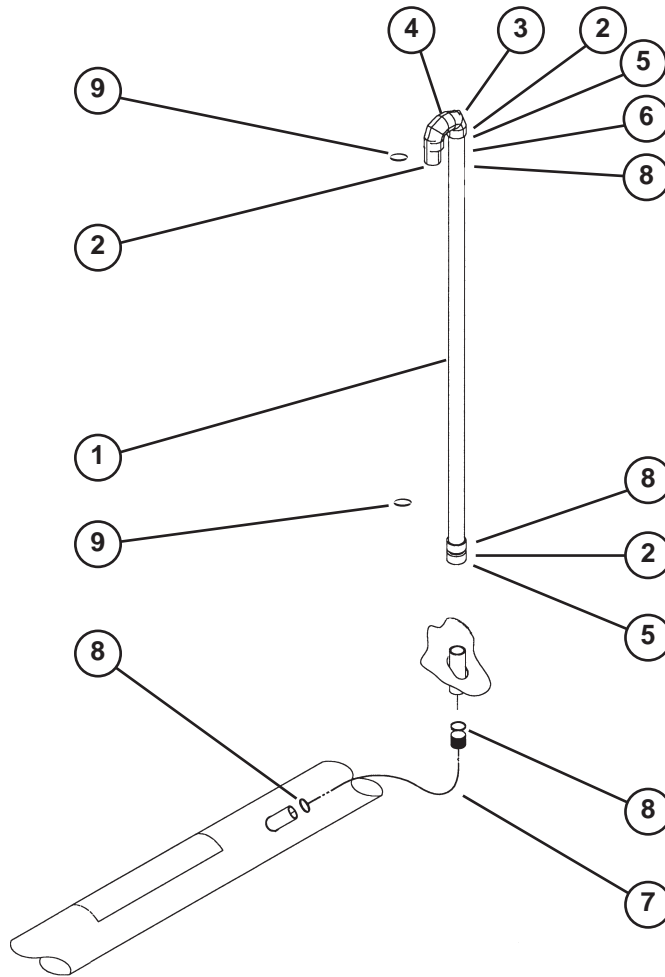

ASSY-PRESSURIZATION KIT

Ref.	Part No.	Description	Qty.
1	65880	HOSE-KANAFLEX 1.25" X INCH LENGTH (2800 AS)	61
		HOSE-KANAFLEX 1.25" X INCH LENGTH (3350 AS)	71
2	65881	PIPE-PVC 1.25" SCH 40 X 4"	4
3	65882	ELBOW-PVC 1.25" SCH 40 F X FG	4
4	65883	PIPE-PVC 1.25" SCH 40 X 3"	2
5	65884	ADAPTER-PVC 1.25" F GLUE X 1.25"	2
6	65885	FTG-PVC 1.25 MP X 1.25 MB	2
7	65880	HOSE-KANAFLEX 1.25" X INCH LENGTH	19.5
8	1013134	CLAMP-HOSE: S.S.#28 1.32-2.25	8
9	65917	CLAMP-HOSE: S.S.#40	4

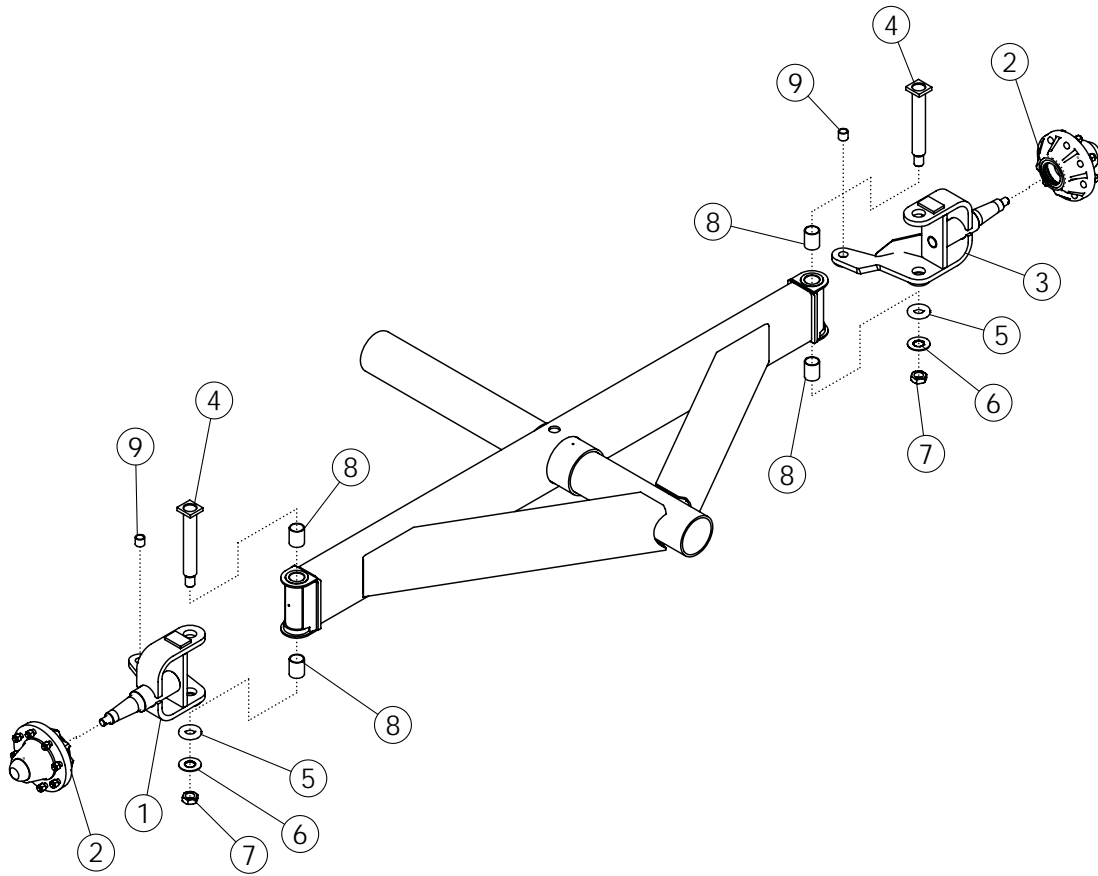

ASSY-AXLES FRONT

Ref.	Part No.	Description	Qty.
1	65429	WLDMT-TRUNION RH	1
2	1017759	ASSY-HUB	2
3	65430	WLDMT-TRUNION LH	1
4	65439	WLDMT-KING PIN	2
5	1020688	BEARING-THRUST: TIMKEN T177	2
6	1020675	WASHER-STAR: INTERNAL 1.25" ZP	2
7	65864	NUT-JAM: 1.25 NF GR2 ZP	2
8	65877	BUSHING-MACHINED	4
9	65879	BUSHING-MACHINED	2

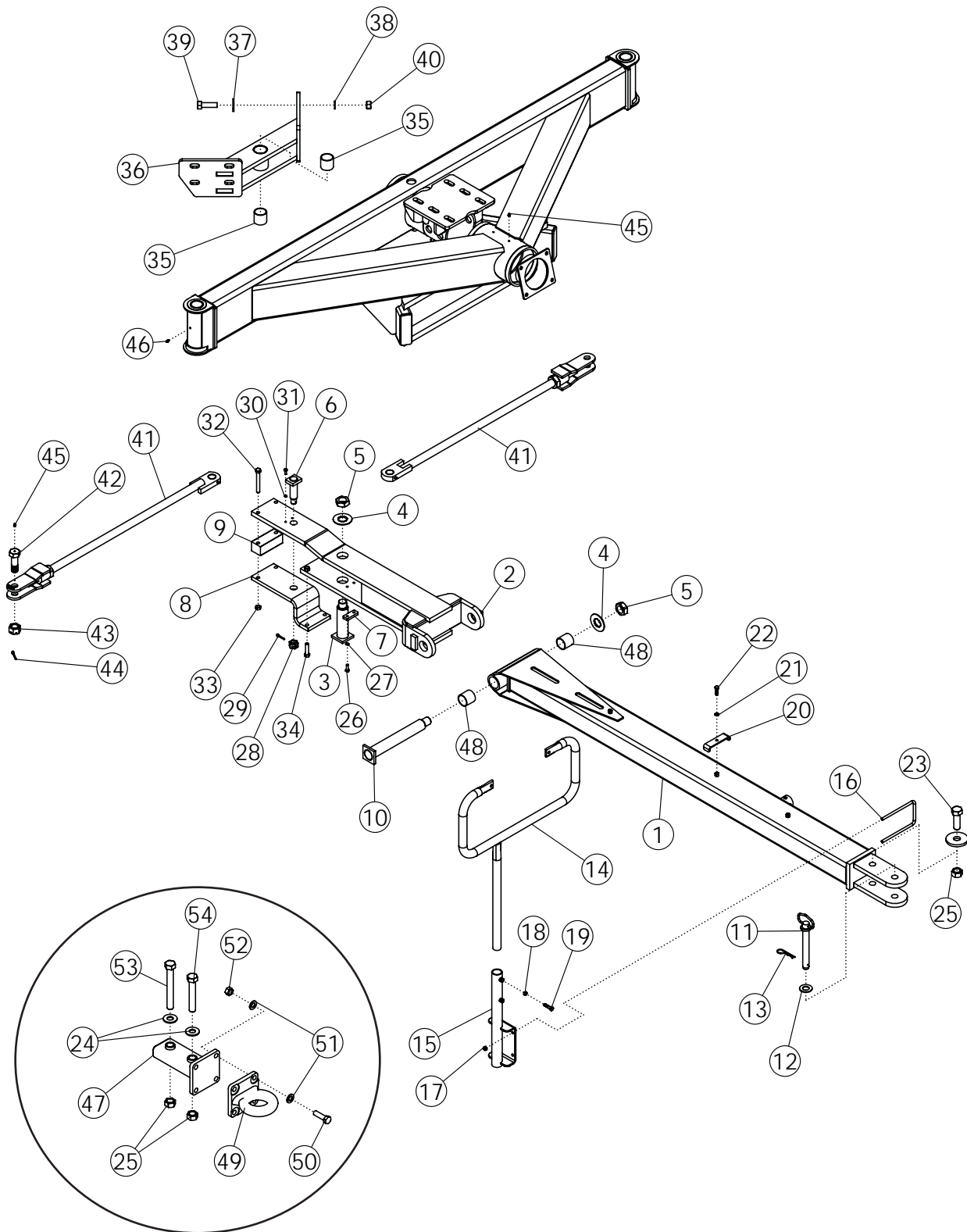

36061 KIT-PINTLE ADAPTER

ASSY-DRAWPOLE & STEERING LINKAGE

Ref.	Part No.	Description	Qty.
1	65431	WLDMT-DRAWPOLE	1
2	65432	WLDMT-HITCH	1
3	65442	WLDMT-KING PIN	1
4	1020675	WASHER-STAR: INTERNAL 1.25 ZP	2
5	65864	NUT-JAM: 1.25 NF GR2 ZP	2
6	65440	WLDMT-KING PIN HITCH	1
7	65435	BAR-STOP PLATED	1
8	65433	BRACKET-HITCH	1
9	65434	BLOCK-SPACER	1
10	65441	WLDMT-TOUNGE HINGE BOLT	1
11	1027881	HITCH PIN	1
12	1016663	WASHER-FLAT	1
13	1016115	PIN-HAIR: .19 X 3.25 ZP	1
14	65887	WLDMT-CRADLE HOSE SUPPORT	1
15	66010	WLDMT-MOUNT HOSE SUPPORT	1
16	66005	U-BOLT: .375 X 7.13 X 4 X 7.13	2
17	1016999	NUT-TOPLOCK	4
18	1013519	NUT-JAM: .38 NC GR2 ZP	2
19	1011602	BOLT-HEX: .38 X 1.50 NC GR5 ZP	2
20	65813	BRACKET	1
21	1011586	WASHER-LOCK: .38 ZP	1
22	1011601	BOLT-HEX: .38 X 1.25 CN GR5 ZP	1
23	1018007	BOLT-HEX: 1.00 X 3.00 NC GR5 ZP	1
24	65317	WASHER-FLAT: 1.125 X 3.50 X .375 ZP	3
25	1016969	NUT-TOPLOCK: 1.00 NC GR5 ZP	3
26	1011598	BOLT-HEX: .31 X 1.00 NC GR5 ZP	1
27	1029115	WASHER-LOCK: .31 ZP	1
28	65679	NUT-HEX: SLOT .88 NF GR5 ZP	1
29	1012375	PIN-COTTER: .19 X 1.50 NP	1
30	1013242	WASHER-LOCK: .25 ZP	2
31	1011595	BOLT-HEX: .25 X .75 NC GR5 ZP	2
32	1032507	BOLT-HEX: .50 X 4.00 NC GR5 ZP	2
33	1027461	NUT-TOPLOCK: .50 NC GR5 ZP	4
34	1011609	BOLT-HEX: .50 X 2.00 NC GR5 ZP	2
35	65876	BUSHING-MACHINED	2
36	65760	WLDMT-HITCH PIVOT	1
37	1030702	WASHER-FLAT: .75 ZP	8
38	1012061	WASHER-LOCK: .75 ZP	8
39	1016598	BOLT-HEX: .75 X 2.50 NC GR5 ZP	8
40	1011620	NUT-HEX: .75 NC GR2 ZP	8
41	66092	ASSY-TIE ROD	2
42	65438	BOLT-TIE ROD ZP	2
43	65680	NUT-HEX: 1.00 NC GR2 ZP	2
44	1013473	PIN-COTTER: .19 X 2.00 NP	2
45	1011748	ZERK-GREASE: .25 UNF STRAIGHT	6
46	1011747	ZERK-GREASE: .25 UNF 90°	2
47	35645	WLDMT-PINTLE INSERT (OPTIONAL)	1
48	65876	BUSHING-MACHINED	4
49	35801	TOW RING-66,000 LB (OPTIONAL)	1
50	62096	BOLT-HEX: .75 X 2.50 NC GR8 ZP	4
51	35132	WASHER-FLAT: SAE .75 YZP GR8	8
52	1011434	NUT: .75 NC GR8 ZP	4
53	1030725	BOLT-HEX: 1.00 X 8.00 NC GR8 ZP	1
54	1032502	BOLT-HEX: 1.00 X 6.00 NC GR8 ZP	1
55	65829	JACK STAND 2000 LB (NOT SHOWN)	1

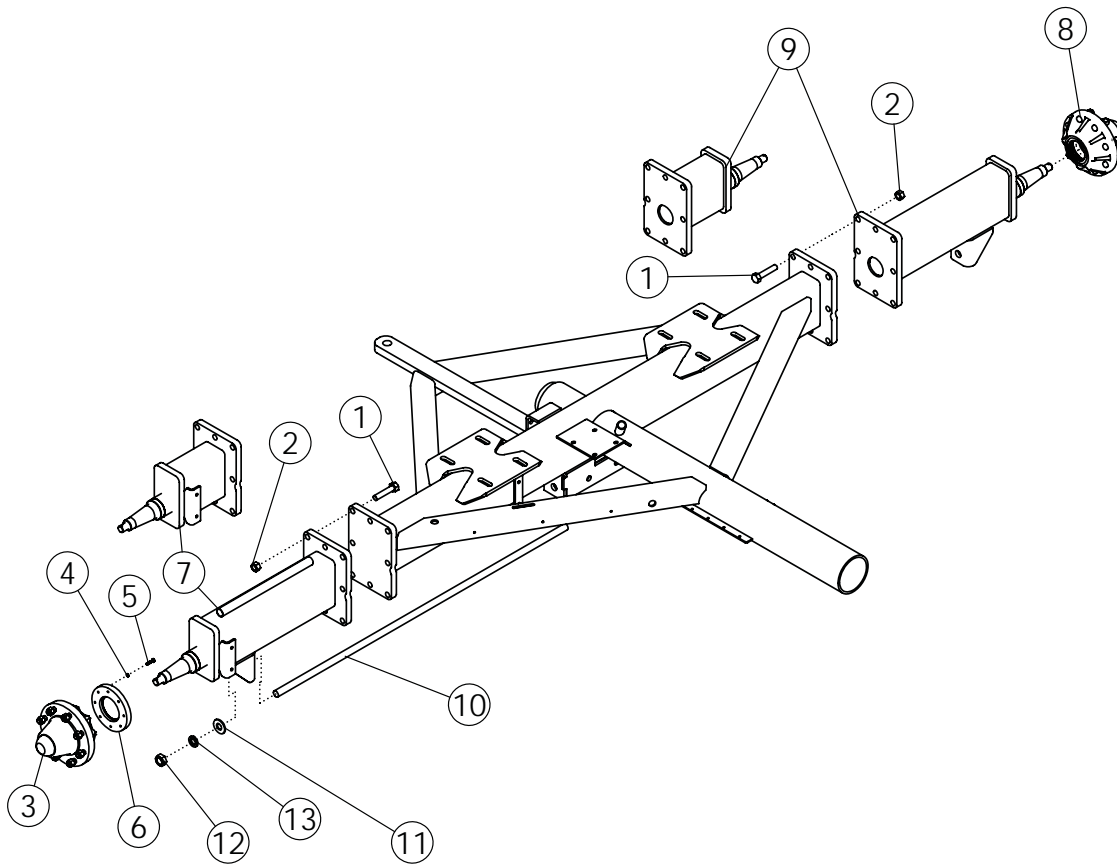

ASSY-AXLES REAR 150"

Ref.	Part No.	Description	Qty
1	58369	BOLT-HEX: .75 X 3.50 NC GR5 ZP	16
2	1013834	NUT-NYLOCK: .75 NC GR2 ZP	16
3	65450	ASSY-HUB: TAPPED	1
4	1013242	WASHER-LOCK: .25	8
5	1013940	BOLT: .25 X 1.25 NC ZP	8
6	65425	FLANGE & SPROCKET	1
7	65436	WLDMT-SPINDLE RH DRIVE (150")	1
	65943	WLDMT-SPINDLE RH (120")	1
8	1017759	ASSY-HUB	1
9	65437	WLDMT-SPINDLE LH (150")	1
	65177	WLDMT-SPINDLE LH (120")	1
10	65683	ROD-TRUSS ZP (150" AXLE ONLY)	2
11	1020685	WASHER-FLAT: 1.00 ZP (150" AXLE ONLY)	4
12	1012664	NUT-HEX: 1.00 NC GR2 ZP (150" AXLE ONLY)	4
13	1013539	WASHER-LOCK: 1.00 ZP (150" AXLE ONLY)	4

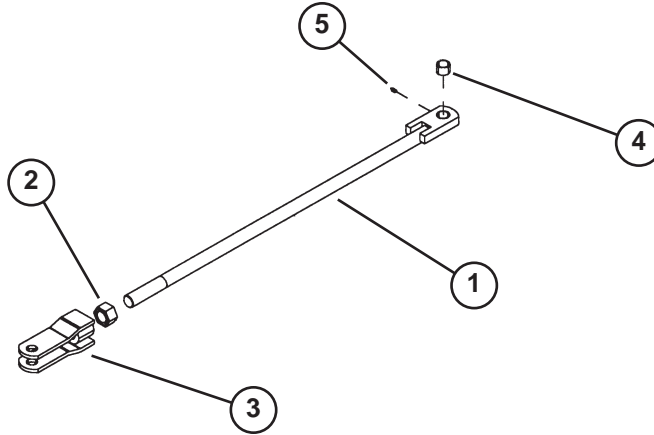

ASSY-TIE ROD

Ref.	Part No.	Description	Qty.
1	65536	TIE ROD - W/BUSHING	1
2	65864	NUT-JAM: 1.25 NF GR2 ZP	1
3	65270	TIE ROD CLEVIS-ZP	1
4	65878	BUSHING-MACHINED	1
5	1011748	ZERK-STRAIGHT: .25 UNF	1

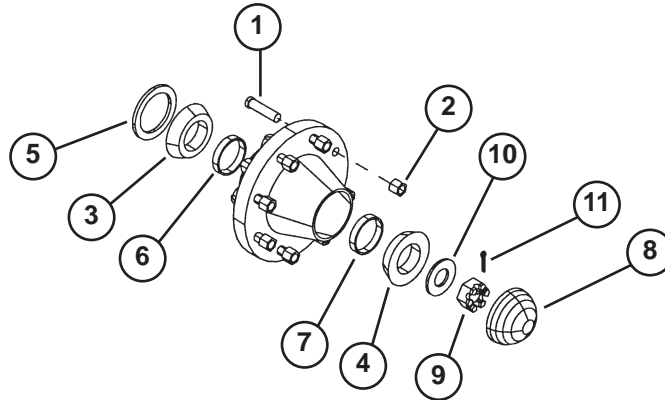

ASSY-HUB

Ref.	Part No.	Description	Qty.
	65450	ASSY-HUB: TAPPED FOR SPROCKET (INCLUDES 1-7)	1
	1017759	ASSY-HUB (INCLUDES 1-7)	3
1	65944	STUD-LUG	8
2	1013470	NUT-BEVELED	8
3	65987	CONE-INNER	1
4	1012354	CONE-OUTER	1
5	1017764	SEAL	1
6	65948	CUP-INNER	1
7	1012359	CUP-OUTER	1
8	53624	CAP-HUB	1
9	1030726	NUT-SPINDLE	1
10	1030728	WASHER-SPINDLE	1
11	1030797	PIN-COTTER	1

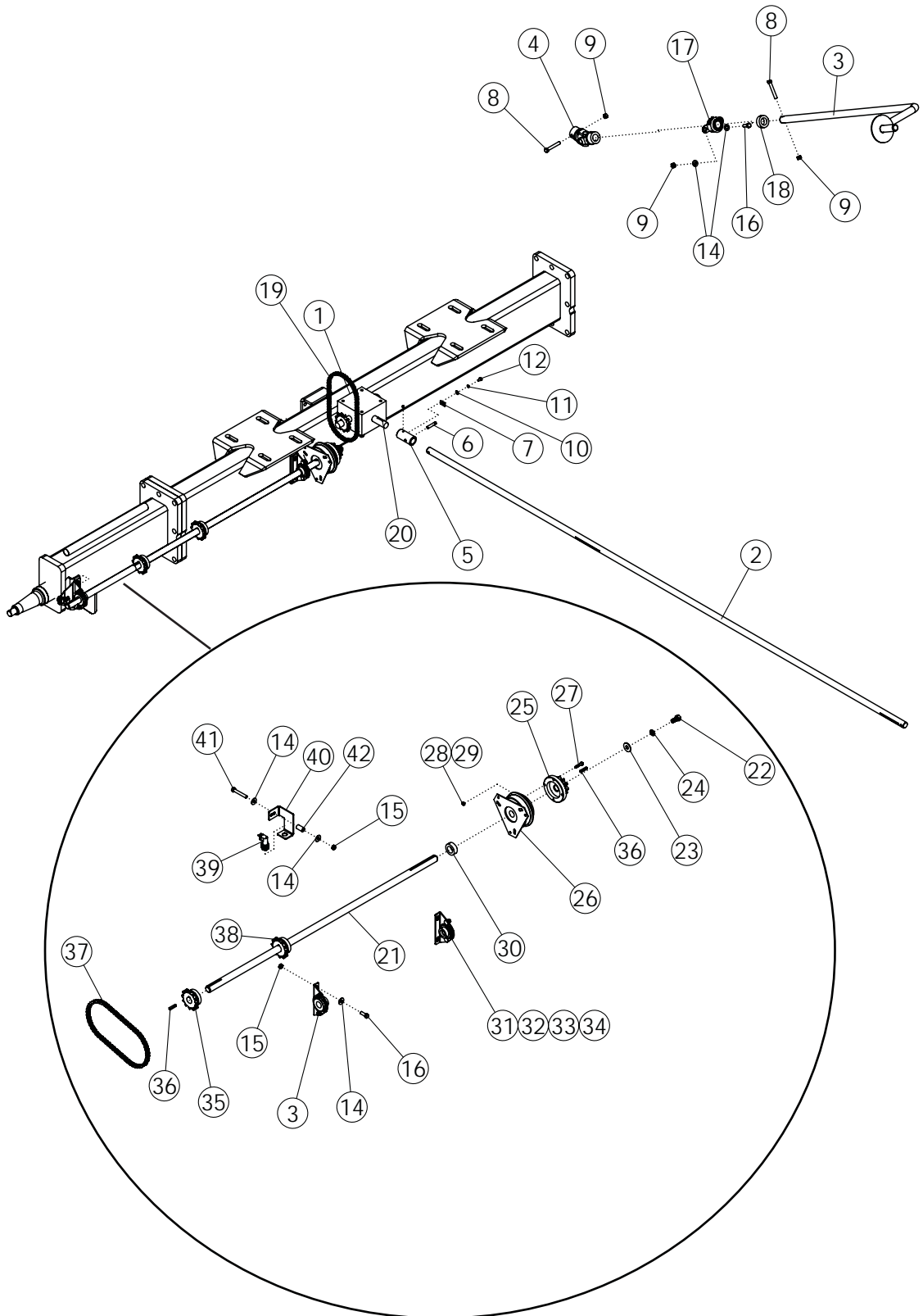

ASSY-METER DRIVELINE

Ref.	Part No.	Description	Qty.
1	65649	GEARBOX-PRARIE (1:1) PAINTED	1
2	65567	SHAFT-METERDRIVE	1
3	65688	WLDMT-METER CRANK	1
4	65826	U-JOINT	1
5	65552	COUPLER	1
6	1013218	PIN-SHEAR: BRASS	1
7	1013221	STRIP-SHEAR PIN	1
8	65693	BOLT-HEX: SS .38 X 2.50 NC	2
9	1033268	NUT-NYLOCK: SS .38 NC GR2	3
10	65695	WASHER-FLAT: SS .25	1
11	65696	WASHER-LOCK: SS .25	1
12	65692	BOLT-HEX: SS .25 X .50 NC	1
13	1013044	SCREW-SET: .25 X .25 NC GR8 NP	1
14	1033262	WASHER-FLAT: SAE SS .38	9
15	1016999	NUT-TOPLOCK: .38 NC GR5 ZP	3
16	1033271	BOLT-HEX: SS .38 X 1.00 NC	6
17	1030961	BEARING FLANGE ASSY MODIFIED	1
18	65694	COLLAR SET SS 1.00	1
19	65699	CHAIN-ROLLER 60-1R-031 NICKEL PLT	1
	65701	LINK-CONNECTOR #60 NICKEL PLT	1
	65725	LINK-OFFSET #60 NICKEL PLT	1
20	65715	KEY .250 X .250 X 1.250 SS	4
21	65945	SHAFT-CLUTCH DRIVE 120" ZP	1
	65654	SHAFT-CLUTCH DRIVE 150" ZP	1
22	1011096	BOLT-HEX: .50 X 1.00 NC GR5 ZP	1
23	1014443	WASHER-FLAT: .50 ZP	1
24	1011581	WASHER-LOCK: .50 ZP	1
25	65553	ASSY-ADAPTER	1
26	1021090	CLUTCH-ELECTRIC	1
27	1013940	BOLT-HEX: .25 X 1.25 NC GR5 ZP	4
28	1011587	NUT-HEX: .25 NC GR2 ZP	4
29	1013242	WASHER-LOCK: .25 ZP	4
30	66181	BUSHING-ADAPTER	1
31	1018571	BEARING-PILLOW BLOCK	2
32	65702	BOLT-CRG: .31 X 0.75 NC GR5 ZP	4
33	1029115	WASHER-LOCK: .31 ZP	4
34	1011575	NUT-HEX: .31 NC GR2 ZP	4
35	1012976	SPROCKET-60BS10 X 1.00 MARTIN	1
36	1012975	KEY .250 X .250 X 1.250	2
37	65703	CHAIN-ROLLER 60-1R-027 NICKEL PL (NOT SHOWN)	1
	65704	LINK-CONNECTOR 60 NICKEL PLATED	1
	65724	LINK-OFFSET #60 NICKEL PLATE	1
38	66075	SPROCKET- 60BS12 X 1.00	1
39	66229	SENSOR-GROUND SPEED	1
	67237	ADAPTER HARNESS (NOT SHOWN)	1
40	66351	BRACKET-SPEED/SHAFT SENSOR DM	1
41	1015174	BOLT-HEX: .38 X 2.50 NC GR5 ZP	1
42	66376	TUBE-SPACER SPEED SENSOR ZP	1

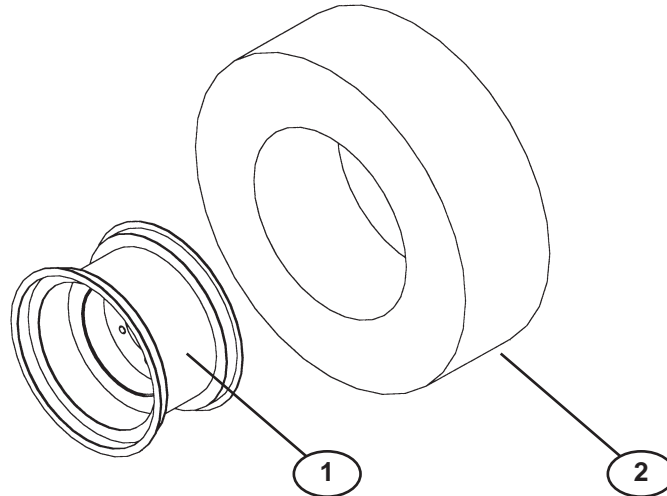

ASSY-W&T 18.4X26 R1 8PLY, 16X26X8

Ref.	Part No.	Description	Qty.
	65685	TIRE-MNTD: 18.4X26 R1 8PLY	4
1	1020719	WHEEL: 16X26 - 8 BOLT	1
2	1030988	TIRE: 18.4X26 R1 8 PLY	1
3	1021069	SPROCKET-GEARBOX: 60BS17 X 1.00 MARTIN (NOT SHOWN)	1

ASSY-W&T 23.1X26 R1 10PLY, 20X26X8

Ref.	Part No.	Description	Qty.
	65687	TIRE-MNTD: 23.1X26 R1 10-PLY	4
1	1021068	WHEEL: 20X26 - 8 BOLT	1
2	1029689	TIRE: 23.1X26 R1 10 PLY	1
3	1025228	SPROCKET-GEARBOX: 60BS15 X 1.00 (NOT SHOWN)	1

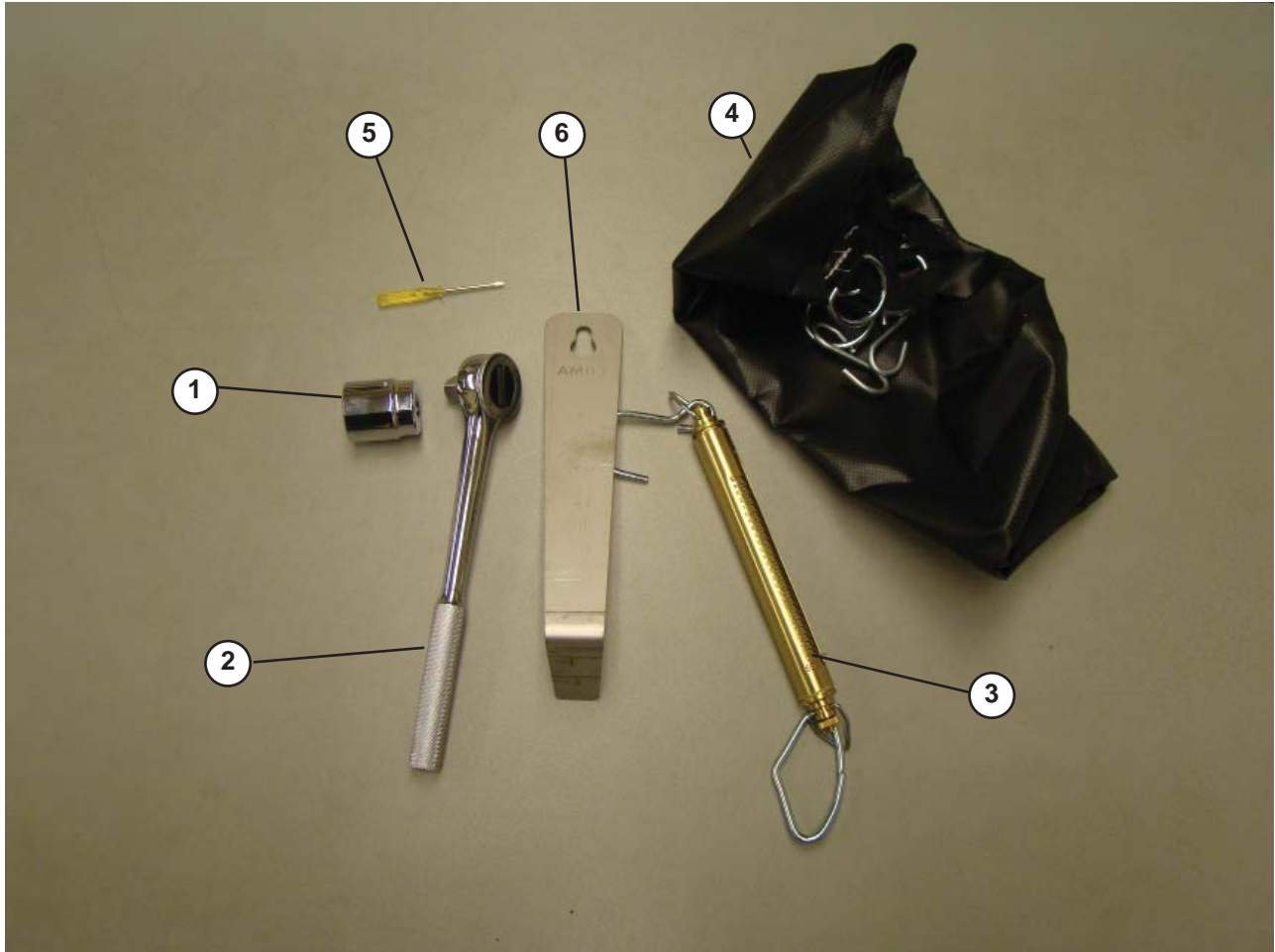

KIT-CALIBRATION COMPONENTS

Ref.	Part No.	Description	Qty.
1	66354	SOCKET-1.125" (.50" DRIVE)	1
2	65890	RATCHET-.50" DRIVE	1
3	1032044	SCALE-CALIBRATION KIT	1
4	1032048	BAG-CALIBRATION KIT	1
5	65891	SCREWDRIVER-FLOW SENSOR	1
6	34569	PLATE-WRENCH SEED DEPTH	1

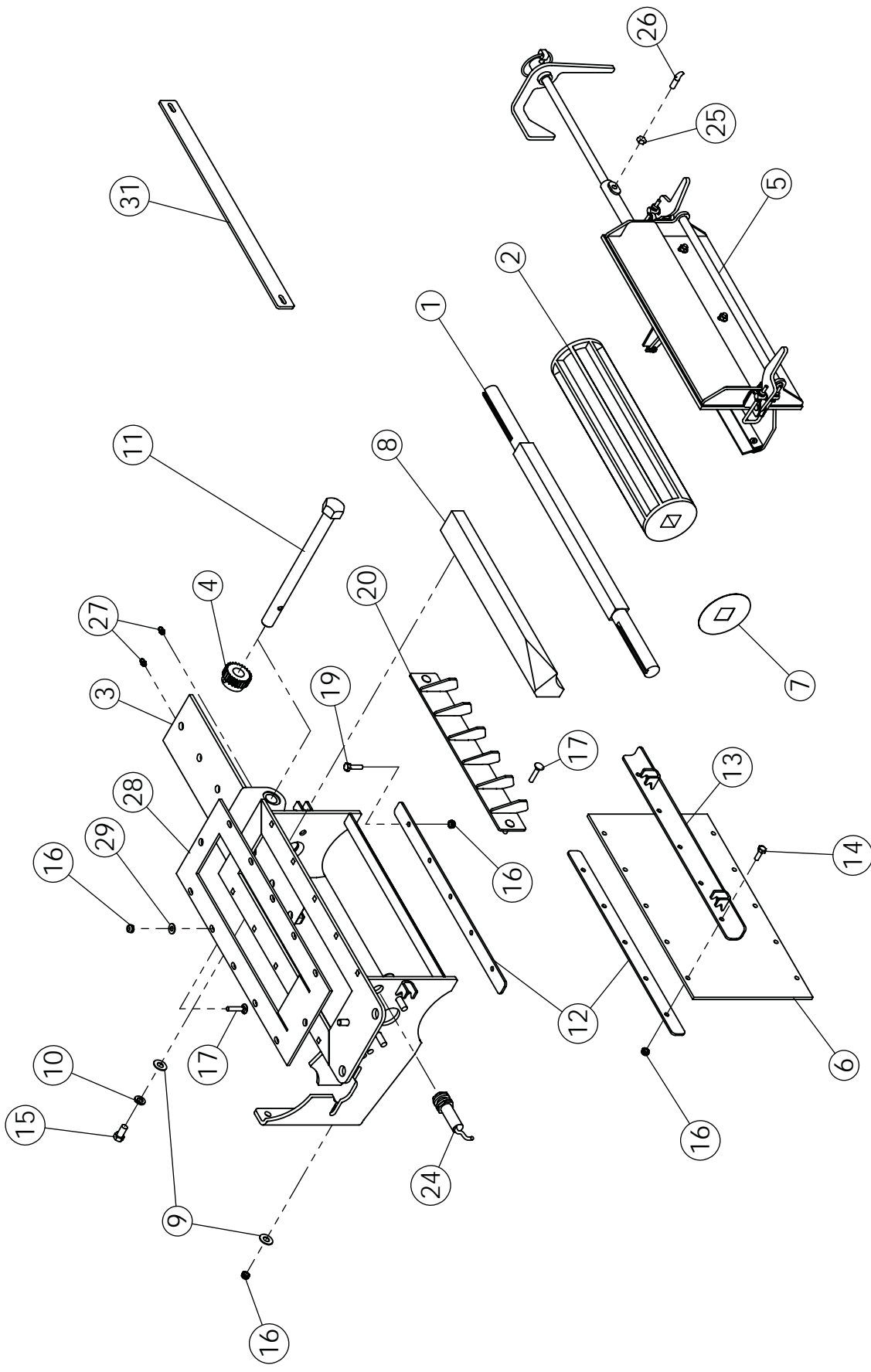

METER BOX ASSEMBLY

Ref.	Part No.	Description	Qty.
1	65650	SHAFT-METER ROLL	1
2	65705	WLDMT-METER ROLL - HIGH VOLUME	1
	1012608	WLDMT-METER ROLL - MEDIUM VOLUME	
	33851	WLDMT-METER ROLL - LOW VOLUME	
3	65632	WLDMT-TOP SLIDE IN DOOR	1
4	65707	PINION-SS	1
5	66306	ASSY-MB DOOR W/FLOW PLATE	1
6	65708	RUBBER CLEANOUT DOOR	17
7	65744	PLATE METER ROLL SPACER	AR
8	66062	BLOCK-METER TOP	1
9	1033262	WASHER-FLAT: SAE SS .38	8
10	1011586	WASHER-LOCK: .38 ZP	2
11	65630	BOLT-PIN ADJUSTMENT	1
12	65629	PLATE-CLEANOUT RETAINER	2
13	65626	WLDMT-ANGLE LATCH	1
14	1033270	BOLT-HEX: SS .25 X .75 NC	5
15	66375	BOLT-HEX: SS .38 X 1.00 NC	2
16	1033269	NUT-NYLOCK: SS .25 BC GR2	20
17	66043	BOLT-CRG: SS .25 X 1.25 NC	12
18	1011576	NUT-HEX: .38 NC GR2 ZP	4
19	66077	BOLT-HEX: SS .25 X 1.00	5
20	67484	WLDMT-MB AIR DAM	1
21	1032044	SCALE-CALIBRATION KIT (NOT SHOWN)	1
22	64503	GLUE-MASTERBRAND GASKET (NOT SHOWN)	1.75
23	66098	ASSY-CLEANOUT DOOR INCLUDES ITEMS 12, 13, 14, 16, 23	1
24	66511	SENSOR TURCK (WITH END)	1
25	1023719	NUT-JAM: SS .31 NC	1
26	66316	SCREW-THUMB SP HEAD .313-18 X .75SS	1
27	1011748	ZERK-GREASE: .25 UNF STRAIGHT	2
28	65512	GASKET-SEEDBOX .250	1
29	65695	WASHER-FLAT: .25 SS	10
30	66097	ASSY-DEFLECTOR (NOT SHOWN)	1
31	65490	PLATE-INDICATOR DECAL	1

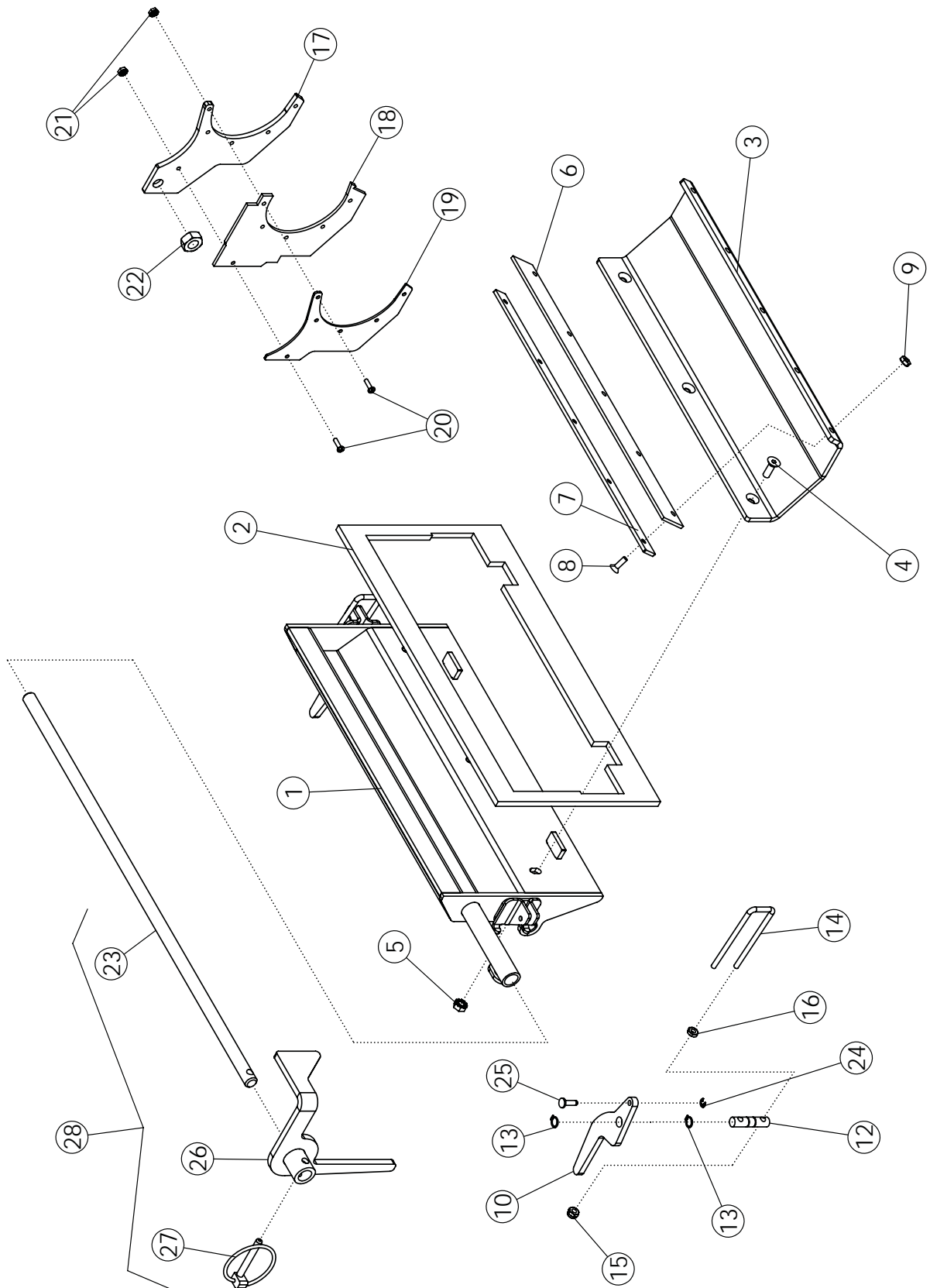

ASSY-METER BOX DOOR

Ref.	Part No.	Description	Qty.
1	66305	WLDMT-MB DOOR	1
2	66344	GASKET-RUBBER MB DOOR	1
3	66300	PLATE-MB SEED TRAY	1
4	66347	SCREW F-H-S-C: .25 X .75 NC SS	3
5	66348	NUT-K-LOCK: .25 NC SS	3
6	66345	WIPER RUBBER	1
7	66310	SHEET-MB WIPER MOUNT	1
8	1032095	SCREW-F-H-S-C: .19 X .625 NC SS	5
9	1032059	NUT-K-LOCK: 18-8 SS .19 NC	5
10	65640	PLATE-METER CLAMP HANDLE	2
12	65639	SHAFT-METER LATCH	2
13	67499	RING-RETAINING .375 SS	4
14	65655	U-BOLT: SS .188 X 3.25 X .875 X 3.25	2
15	65712	NUT-NYLOCK: 10-24 GR2 SS	4
16	65348	NUT-HEX: SS 10-24	4
17	66307	PLATE-MB FLOW CONTROL	1
18	66346	SEAL-RUBBER FLOW CONTROL	1
19	66309	PLATE-MB FLOW CONTROL	1
20	1032093	SCREW-P-H: #6 X .50 NC SS	6
21	1032094	NUT-K-LOCK: 18-8 SS .19 NC	6
22	1032190	NUT-JAM: .50 NC SS	1
23	65661	ROD-FLOW CONTROL	1
24	67498	E-CLIP: .188 SS	2
25	67497	PIN-METER LATCH	2
26	65662	WLDMT-INDICATOR	1
27	65311	PIN-LYNCH: .25 X 1.563	1
28	65651	ASSY-FLOW CONTROL ROD	1

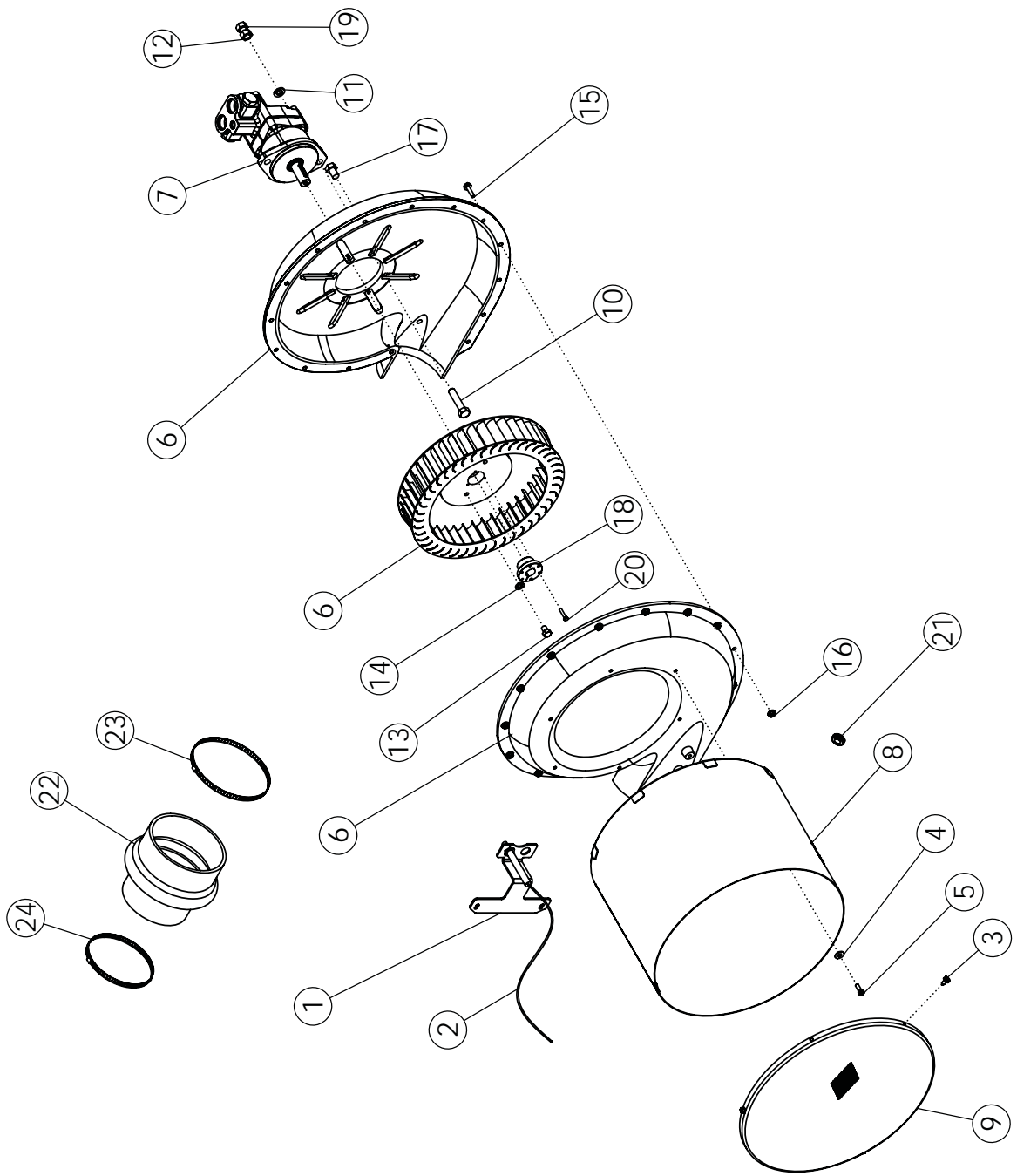

ASSY-BLOWER

Ref.	Part No.	Description	Qty.
1	66350	BRACKET-FAN SPEED SENSOR	1
2	66510	SENSOR-FAN SPEED (ISO)	1
3	1020555	SCREW-ZIPIN TAP: #12 X 1/2"	3
4	1020416	WASHER-FLAT: .25 ZP	6
5	1011595	BOLT-HEX: .25 X .75 NC GR5 ZP	6
6	1020418	FAN-HYDRAULIC DRIVE 6"	1
7	66244	MOTOR-HYDRAULIC W/CHECK PAINTED	1
	66752	SEAL-MOTOR SHAFT	
8	1020543	WLDMT-SCREEN	1
9	1020540	SCREEN-END	1
10	1017708	BOLT-HEX: .50 X 2.25 NC GR5 ZP	2
11	1011581	WASHER-LOCK: .50 ZP	2
12	1011577	NUT-HEX: .50 NC ZP	2
13	1021800	BOLT-HEX: .38 X .50 NC GR5 ZP	2
14	1011586	WASHER-LOCK: .38 ZP	2
15	63671	BOLT-FLANGE: .25 X 1.00 NC GR5 ZP	15
16	65349	NUT-FLANGE: .25 NC GR5 ZP	15
17	1013020	BOLT-HEX: .50 X .75 NC FR5 ZP	2
18	1020459	BUSHING 20MM	1
19	1027461	NUT-TOPLOCK: .50 NC GR5 ZP	2
20	66099	ASSY-BLOWER HYDRAULIC	1
21	67511	GROMMET-RUBBER 13/16"	1
22	1014892	HOSE-HUMP REDUCER	1
23	66221	CLAMP-HOSE: #104 4.13-7.00	1
24	1026256	CLAMP-HOSE: #88 3.13-6.00	1
25	66099	ASSY-BLOWER HYDRAULIC (INCLUDES ITEMS 3-19)	1
26	1020801	SCREEN 6" (INCLUDES ITEMS 3, 8, AND 9)	1

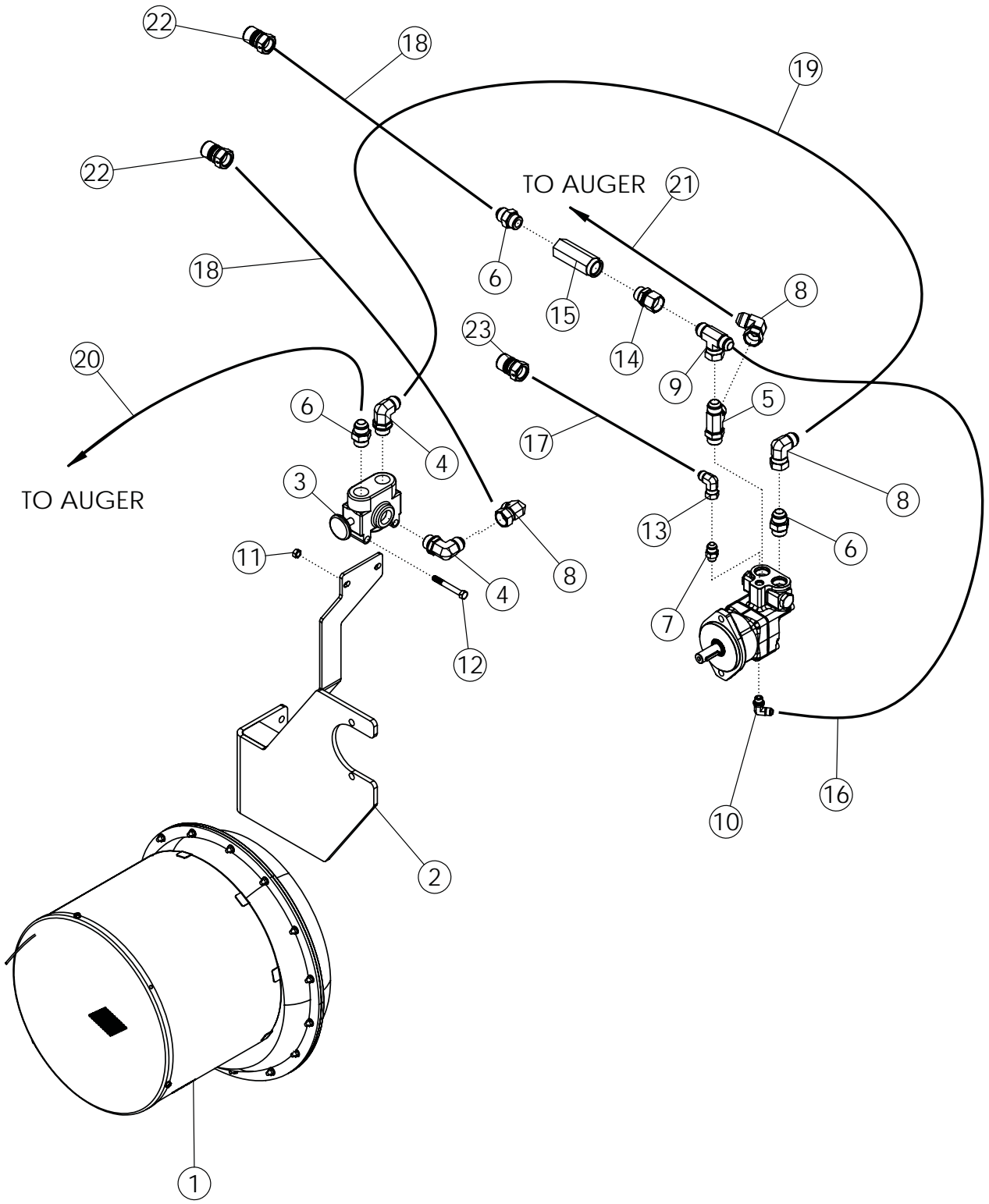

ASSY-BLOWER HYDRAULIC GROUND DRIVE

Ref.	Part No.	Description	Qty.
1	66099	ASSY-BLOWER HYDRUALIC	1
2	65718	WLDMT - FAN MOUNT	1
3	65846	VALVE-SELECTOR PAINTED (3-WAY)	1
4	64060	12MB-12MJ-90	2
5	66248	12MB-12MJ-12MJ	1
6	65918	FTG-ADAPTER: 12MB-12MJ	3
7	62024	6MB-8MJ	1
8	59041	12MJ-12FJX-90	3
9	59053	12MJ-12MJ-12FJX TEE	1
10	66270	6MB-6MJ-90	1
11	1016999	NUT-TOPLOCK: .38 NC GR5 ZP	2
12	1013239	BOLT-HEX: .38 X 3.00 NC GR5 ZP	2
13	57668	8MJ-8FJX-90	1
14	66249	FTG-ADAPTER: 12MB-12FJX	1
15	65857	VALVE-CHECK SAE #12	1
16	66269	HOSE: .50 X 020 12FJX-6FJX90L	1
17	1017135	HOSE: .50 X 312 8MP-8FJX	1
18	65894	HOSE: .75 X 310 12FJX-12MP	2
19	65918	HOSE: .75 X 024 12FJX-12FJX	1
20	65898	HOSE: .50 X 240 12FJX-12FJX-90 (8" AND 10")	1
21	65897	HOSE: .50 X 240 12FJX-12FJX (8" AND 10")	1
22	65323	QUICK COUPLING-MALE 12-12	2
23	65324	QUICK COUPLING-MALE 8-10	1

+ CASE DRAIN COUPLERS AT TRACTOR

Ref.	Part No.	Description	Qty.
24	69119	FTG-CASE DRAIN JD & CNH (NOT SHOWN)	AR
25	69120	FTG-MOTOR RETURN LINE (NOT SHOWN)	AR
26	66199	PIONEER TIP 8010-15 (NOT SHOWN)	AR
27	66961	FTG-ADAPTER: 8FB-12MB (NOT SHOWN)	AR
28	65318	QUICK COUPLING-FEMALE -12-12 NPT (NOT SHOWN)	AR
29	65319	QUICK COUPLING-FEMALE -8-10 NPT (NOT SHOWN)	AR

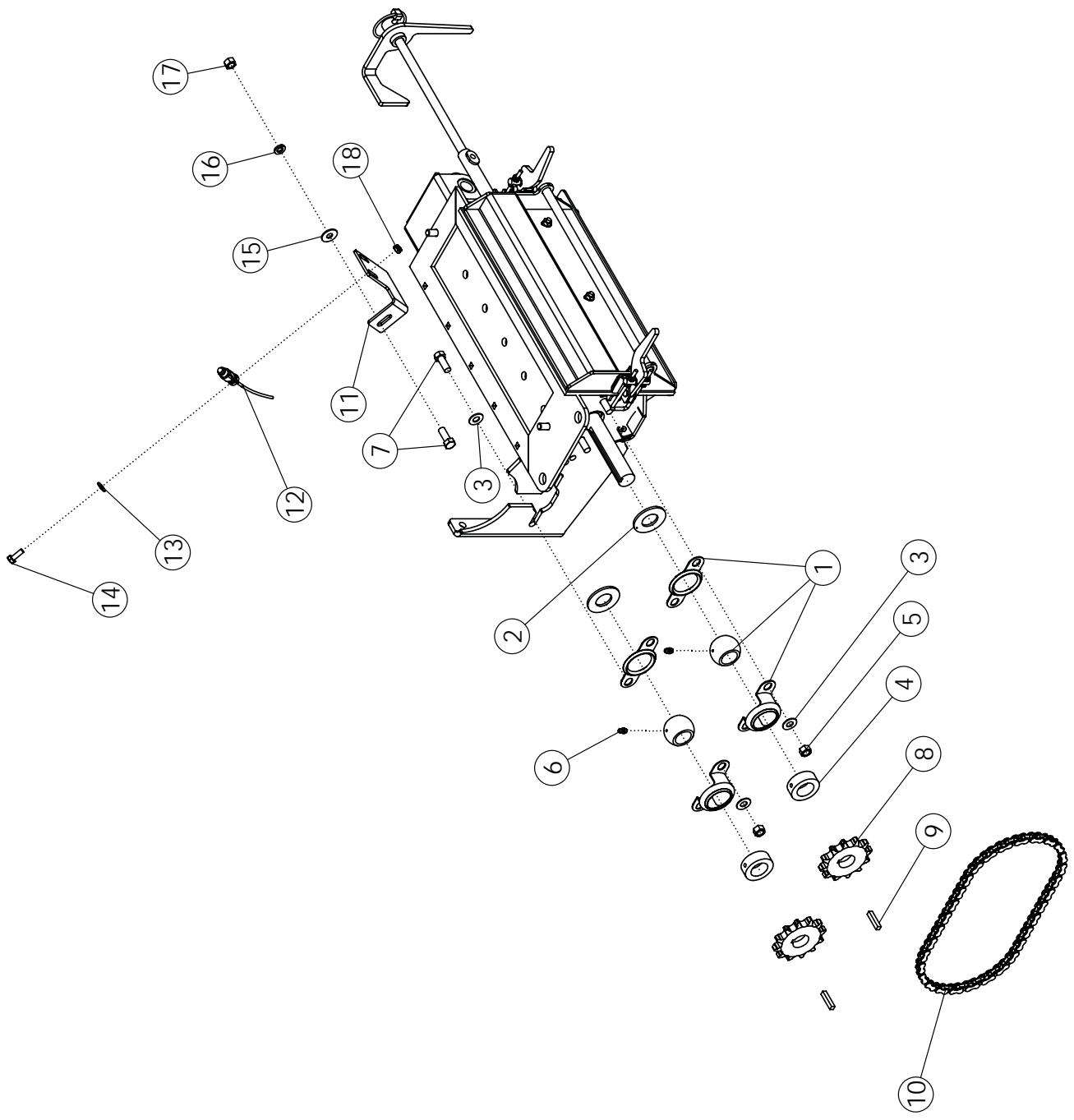

ASSY-GROUND DRIVE

Ref.	Part No.	Description	Qty.
1	1012986	BEARING-FLANGE/A	2
2	1012978	WASHER-RUBBER	2
3	1033262	WASHER-FLAT: SAE SS .38	5
4	65694	COLLAR-SET: 1.00 SS	2
5	1011576	NLUT-HEX: .38 NC GR2 ZP	4
6	1011748	ZERK-GREASE: .25 UNF STRAIGHT	3
7	1033271	BOLTL-HEX: SS .38 X 1.00 NC	2
8	65698	SPROCKET SS #40	2
9	65715	KEY .250 X .250 X 1.250 SS	2
10	65700	CHAIN ROLLER 40-1R-039 SS	1
	65697	LINK CONNECTOR SS #40	1
	65726	LINK OFFSET #40 SS	1
11	66587	BRACKET-SHAFT SENSOR	1
12	66507	SENSOR-SPEED/SHAFT	1
13	65695	WASHER-FLAT: SS .25	1
14	1033270	BOLT-HEX: SS .25 X .75 NC	1
15	65778	WASHER-FLAT: SS .38	1
16	65706	WASHER-LOCK: SS .38	1
17	10320589	NUT-HEX: SS .38 NC	1
18	1033269	NUT-NYLOCK: SS .25 NC GR2	1

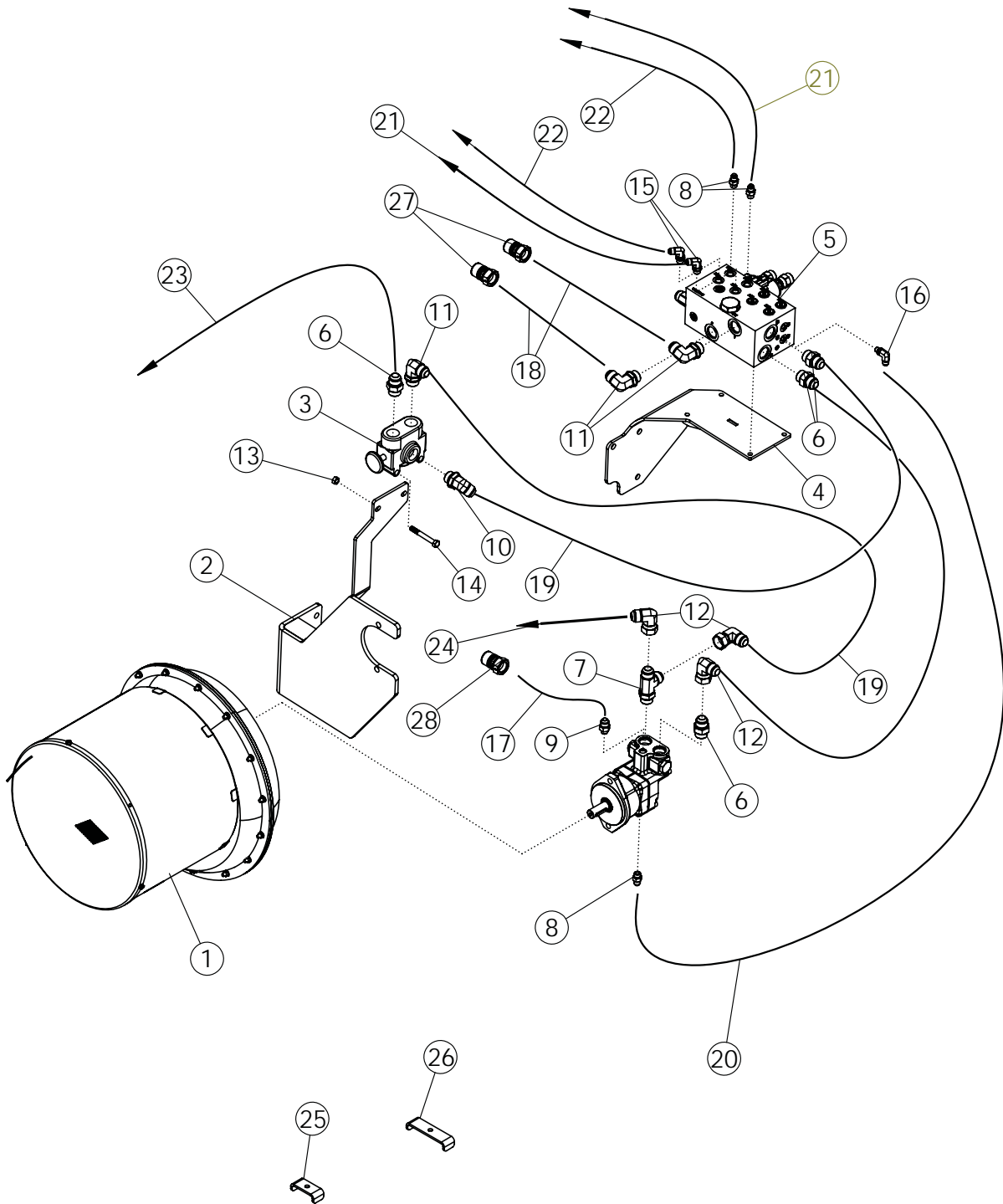

ASSY-BLOWER HYDRAULIC VARIABLE RATE DRIVE

Ref.	Part No.	Description	Qty.
1	66099	ASSY-BLOWER	1
2	65718	WLDMT-FAN MOUNT	1
3	65846	VALVE-SELECTOR PAINTED (3-WAY)	1
4	67500	WLDMT-VALVE MOUNT	1
5	66938	VALVE-VARIABLE RATE 2-BANK W/CHECK	1
6	65918	FTG-ADAPTER: 12MB-12MJ	4
7	66248	FTG-TEE: 12MB-12MJ-12MJ	1
8	37259	FTG-ADAPTER: 6MB-6MJ	3
9	62024	FTG-ADAPTER: 6MB-8MJ	1
10	63699	FTG-ELBOW: 12MB-12MJ-45	1
11	64060	FTG-ELBOW: 12MB-12MJ-90	3
12	59041	FTG-ELBOW: 12MJ-12FJX-90	3
13	1016999	NUT-TOPLOCK: .38 NC GR5 ZP	2
14	1013239	BOLT-HEX: .38 X 3.00 NC GR5 ZP	2
15	57754	FTG-ELBOW: 6MB-6MJ 90	2
16	67513	FTG-ELBOW: 4MB-6MJ 90	1
17	1017135	HOSE: .50 X 312 8MP-8FJX	1
18	65894	HOSE: .75 X 310 12FJX-12MP	2
19	66245	HOSE: .75 X 024 12FJX-12FJX	3
20	67505	HOSE: .38 X 018 6FJX-6FJX	1
21	67506	HOSE: .38 X 080 6FJX-6FJX90	2
22	67507	HOSE: .38 X 150 6FJX-6FJX90	2
23	65898	HOSE: .50 X 240 12FJX-12FJX-90 (8" AND 10")	1
24	65897	HOSE: .50 X 240 12FJX-12FJX (8" AND 10")	1
25	50714	CLAMP .50 ZP	1
26	65813	BRACKET	3
27	65323	QUICK COUPLING-MALE 12-12	2
28	65324	QUICK COUPLING-MALE 8-10	1

+ CASE DRAIN COUPLERS AT TRACTOR

Ref.	Part No.	Description	Qty.
29	69119	FTG-CASE DRAIN JD & CNH (NOT SHOWN)	AR
30	69120	FTG-MOTOR RETURN LINE (NOT SHOWN)	AR
31	66199	PIONEER TIP 8010-15 (NOT SHOWN)	AR
32	66961	FTG-ADAPTER: 8FB-12MB (NOT SHOWN)	AR
33	65318	QUICK COUPLING-FEMALE -12-12 NPT (NOT SHOWN)	AR
29	65319	QUICK COUPLING-FEMALE -8-10 NPT (NOT SHOWN)	AR

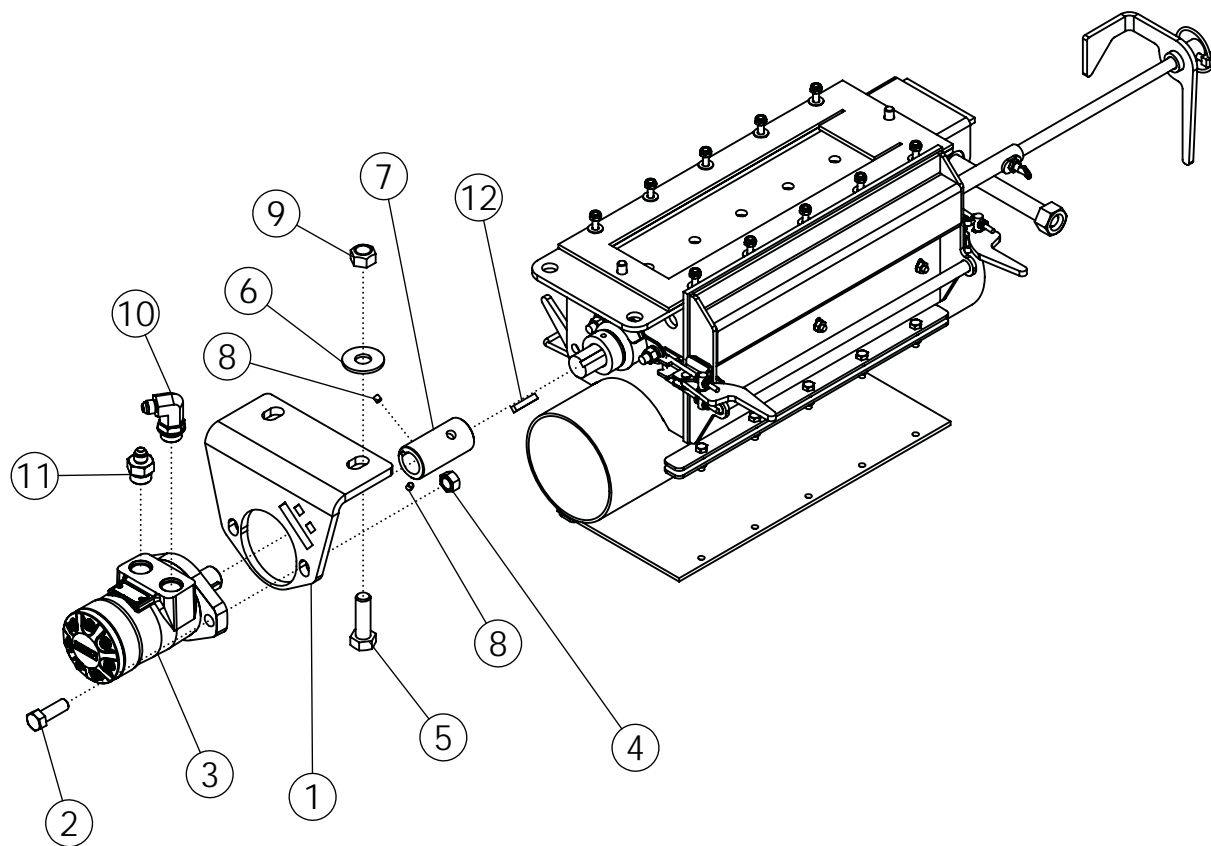

ASSY-VARIABLE RATE DRIVE

Ref.	Part No.	Description	Qty.
1	34038	MOUNT-HYD MOTOR METER	1
2	1011607	BOLT-HEX: .50 x 1.50 NC GR5 ZP	2
3	67481	MOTOR-METER DRIVE 9.7 CID	1
4	1027461	NUT-TOPLOCK: .50 NC GR5 ZP	2
5	34808	BOLT-HEX: SS .63 X 2.00 NC	2
6	67496	WASHER-FLAT: .63 SS	2
7	65552	COUPLER	1
8	1013044	SCREW-SET: .25 X .25 NC GR8 NP	2
9	66445	NUT-NYLOCK: .63 NC GR2 SS	2
10	37042	FTG-ELBOW: 10MB-6MJ 90	1
11	66939	FTG-ADAPTER: 6MJ-10MB	1
12	65715	KEY .250 X .250 X 1.250 SS	1
13	67489	HARNES-METER SPEED (NOT SHOWN)	1

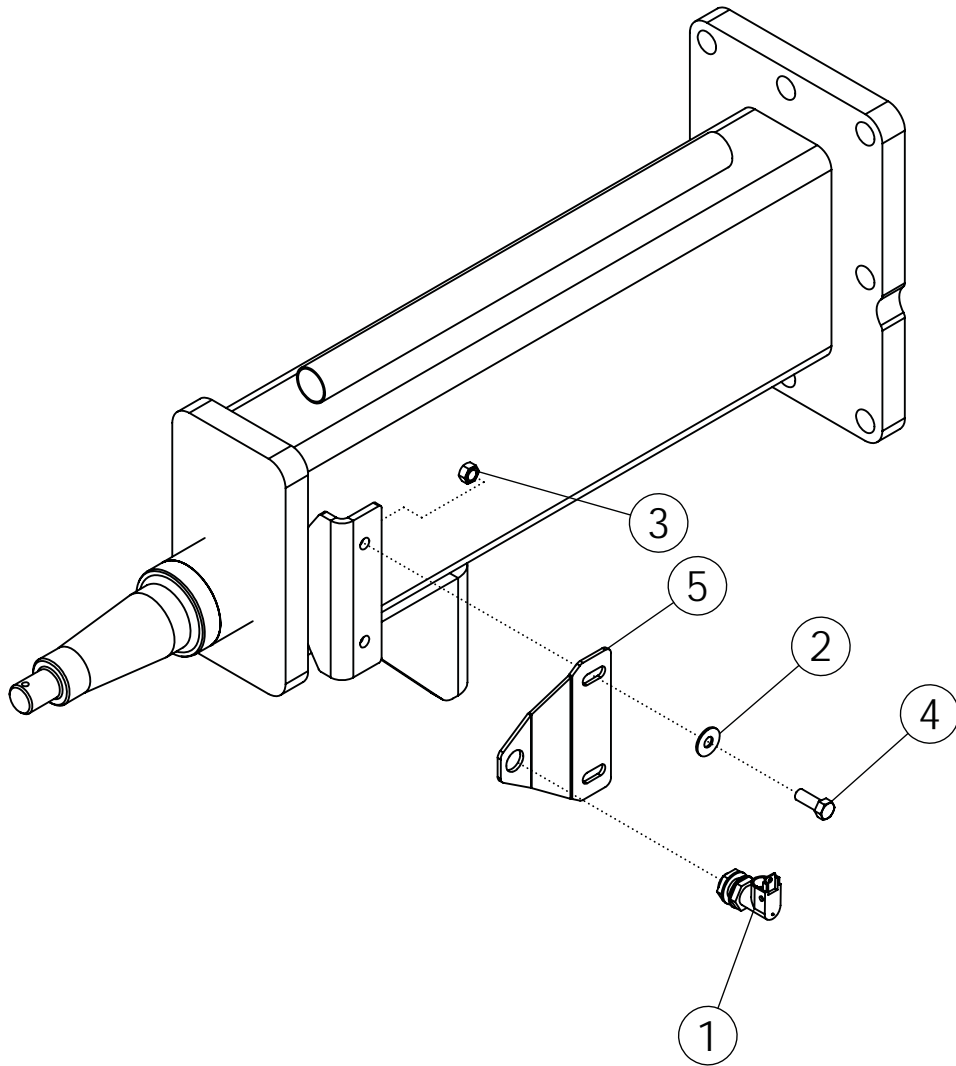

ASSY-VARIABLE RATE GROUND SPEED SENSOR

Ref.	Part No.	Description	Qty.
1	66229	SENSOR-GROUND SPEED	1
2	1011828	WASHER-FLAT .38 ZP	2
3	1016999	NUT-TOPLOCK: .38 NC GR5 ZP	2
4	1011600	BOLT-HEX: .38 X 1.00 NC GR5 ZP	2
5	66984	BRACKET-SPEED SENSOR VR	1
6	65436	WLDMT- SPINDLE RH	1
7	67237	HARNESS-ADAPTER M-DIN TO DEUTSCH (NOT SHOWN)	1

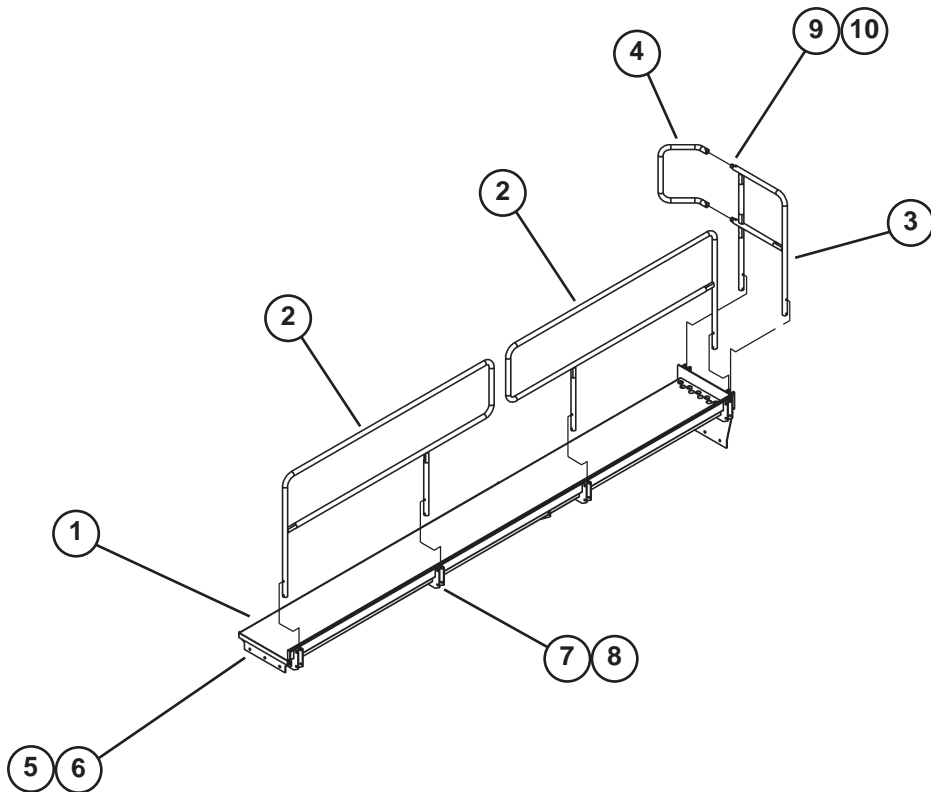

ASSY-CATWALK & HANDRAILS

Ref.	Part No.	Description	Qty.
1	65589	WLDMT-CATWALK	1
2	65598	WLDMT-SIDE RAIL	2
3	65601	WLDMT-FRONT RAIL	1
4	65606	TUBE-FRONT RAILING	1
5	1011606	BOLT-HEX: .50 X 1.25 NC GR5 ZP	9
6	1027461	NUT-TOPLOCK: .50 NC GR5 ZP	9
7	1015174	BOLT-HEX: .38 X 2.50 NC GR5 ZP	12
8	1016999	NUT-TOPLOCK: .38 NC GR5 ZP	12
9	1011603	BOLT-HEX: .38 X 1.75 NC GR5 ZP	2
10	1016999	NUT-TOPLOCK: .38 NC GR5 ZP	2

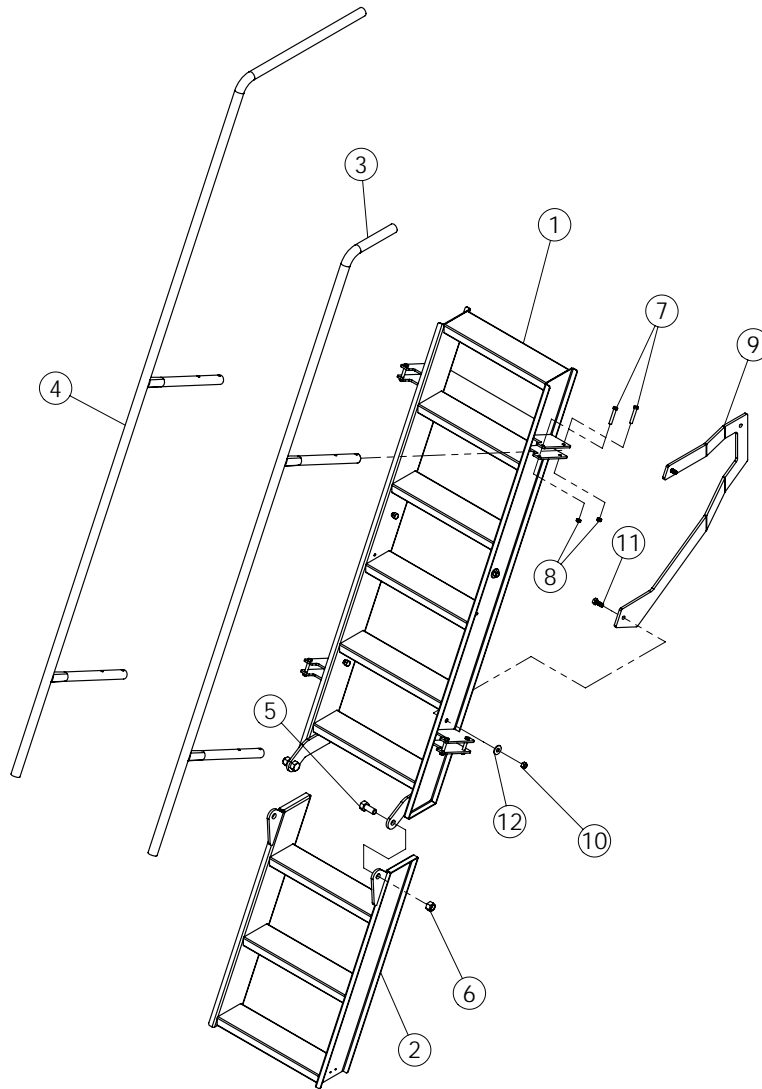

ASSY-LADDER AIR SYSTEM

Ref.	Part No.	Description	Qty.
1	65607	WLDMT-UPPER LADDER	1
2	65617	WLDMT-LOWER LADDER	1
3	65623	WLDMT-LADDER RAIL RH	1
4	66377	WLDMT-LADDER RAIL LH	1
5	62412	BOLT-HEX: .75 X 1.75 NC GR5 ZP	2
6	1017000	NUT-TOPLOCK: .75 NC GR5 ZP	2
7	59390	BOLT-HEX: .38 X 2.25 NC GR5 ZP	8
8	1016999	NUT-TOPLOCK: .38 NC GR5 ZP	8
9	67100	MOUNTING BRACKET RH	1
	67099	MOUNTING BRACKET LH (NOT SHOWN)	1
10	1027461	NUT-TOPLOCK: .50 NC GR5 ZP	4
11	1011606	BOLT-HEX: .50 X 1.25 NC GR5 ZP	4
12	1014443	WASHER-FLAT: .50 ZP	4

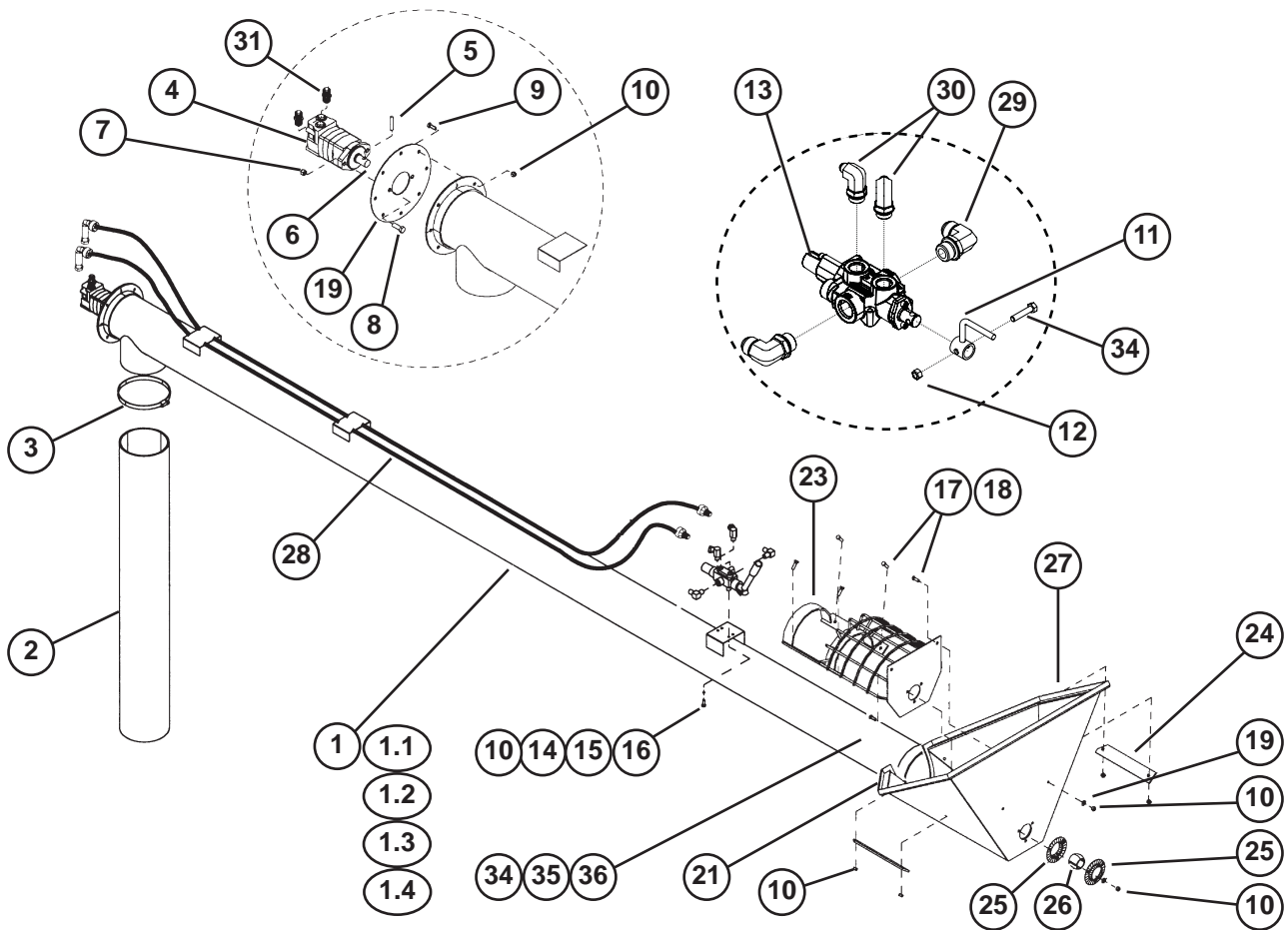

ASSY-AUGER & HYDRAULICS (8"/10")

Ref.	Part No.	Description	Qty.
1	65719	ASSY-AUGER 8.00" X 18'	1
	66101	ASSY-AUGER 10"	1
1.1	65903	POLY FLIGHTING: 7.00" X 18'	1
	66104	POLY FLIGHTING: 9.00" X 21'	1
1.2	65906	TUBE-AUGER: 8.00" X 18'	1
	66103	TUBE-AUGER: 10.00" X 21'	1
1.3	66259	POLY FLIGHTING: 7.00" X 6" LG - REPLACEMENT SECTION	REF
	66260	POLY FLIGHTING: 9.00" X 6" LG - REPLACEMENT SECTION	REF
1.4	66418	FLIGHTING-STEEL: 7.00' X 18'	1
	33582	FLIGHTING-STEEL: 9.00' X 21'	1
2	65714	HOSE-FLEX SPOUT 8" X 48"	1
	66102	HOSE-FLEX SPOUT 10"	1
3	66220	CLAMP-HOSE #152 (8")	1
	66256	CLAMP-HOSE #188 (10")	1
4	1032092	MOTOR-HYDRAULIC PAINTED	1
	1023837	SEAL-KIT: CHARLYNN 61258	
5	66079	BOLT-HEX: SS .375 X 2.75 NC	1
6	1033268	NUT-NYLOCK: .38 NC GR2 SS	1
7	65313	NUT-NYLOCK: .50 NC GR2 ZP	2
8	1011607	BOLT-HEX: .50 X 1.50 NC GR5 ZP	2
9	1011600	BOLT-HEX: .38 X 1.00 NC GR5 ZP	8
10	1013338	NUT-NYLOCK: .38 NC GR2 ZP	19
11	66107	HANDLE-AUGER VALVE ZP	1

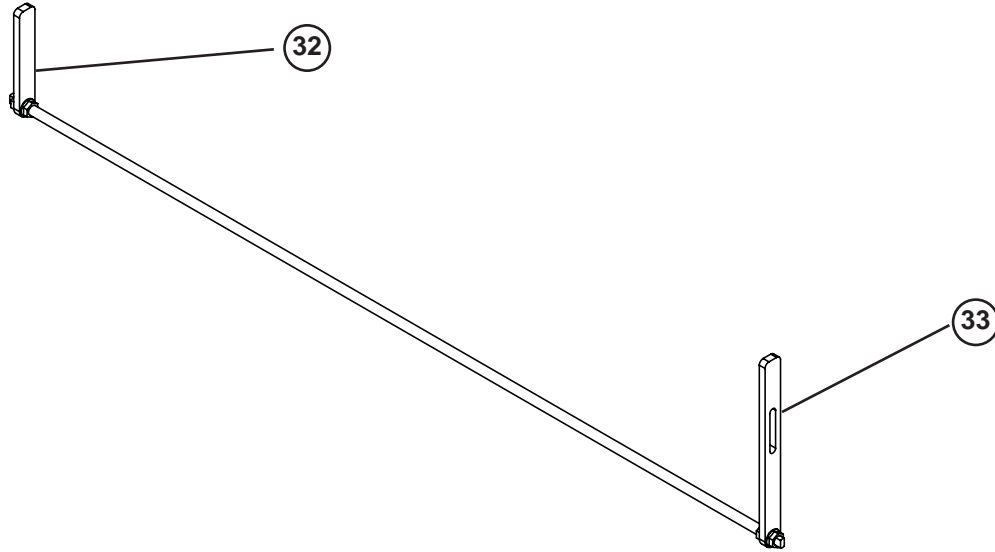

ASSY-AUGER & HYDRAULICS (8"/10") (continued)

Ref.	Part No.	Description	Qty.
12	58747	NUT-HEX: .31 NF GR5 ZP	2
13	65845	VALVE-CONTROL 4 WAY PAINTED	1
14	1019550	BOLT-HEX: .25 X 1.50 NC GR5 ZP	3
15	1013242	WASHER-LOCK: .25 ZP	3
16	1011587	NUT-HEX: .25 NC GR2 ZP	3
17	1011586	WASHER-LOCK: .38 ZP	4
18	1011601	BOLT-HEX: .38 X 1.25 NC GR5 ZP	4
19	1011828	WASHER-FLAT: .38 ZP	4
20	65723	HOSE KIT: AIR SYSTEM - REFERENCE	1
21	65907	HOPPER-POLY: 8"	1
	66277	HOPPER-POLY: 10"	1
22	65908	PLATE-MOTOR MOUNT: 8"	1
	66257	PLATE-MOTOR MOUNT: 10"	1
23	65912	MOUNT-HOPPER: 8"	1
	66258	MOUNT-HOPPER: 10"	1
24	65913	PLATE-BACKING	2
25	65914	BEARING-FLANGE	2
26	65915	BEARING-WOOD: 1.25	1
	33650	BEARING-WOOD: 1.50	1
27	65916	MESH-HOPPER: 8" (NOT SHOWN)	1
	66337	MESH-HOPPER: 10" (NOT SHOWN)	1
28	65896	HOSE-.50 X 156" 8FJX-8FJX-90	2
29	64060	FTG-ELBOW: 12MB-12MJ-90	2
30	65901	FTG-ELBOW: 10MB-8MJ-90	2
31	58195	FTG-ADAPT: 10MB-8MJ	2
32	66443	TOP HANDLE	1
33	66442	BOTTOM HANDLE	1
34	1014124	BOLT-HEX: .31 X 1.50 NC GR5 ZP	1
		DECALS - REFERENCE PAGE 51	
34	65644	DECAL-DANGER	REF
35	65646	DECAL-WARNING	REF
36	65647	DECAL-DANGER	REF

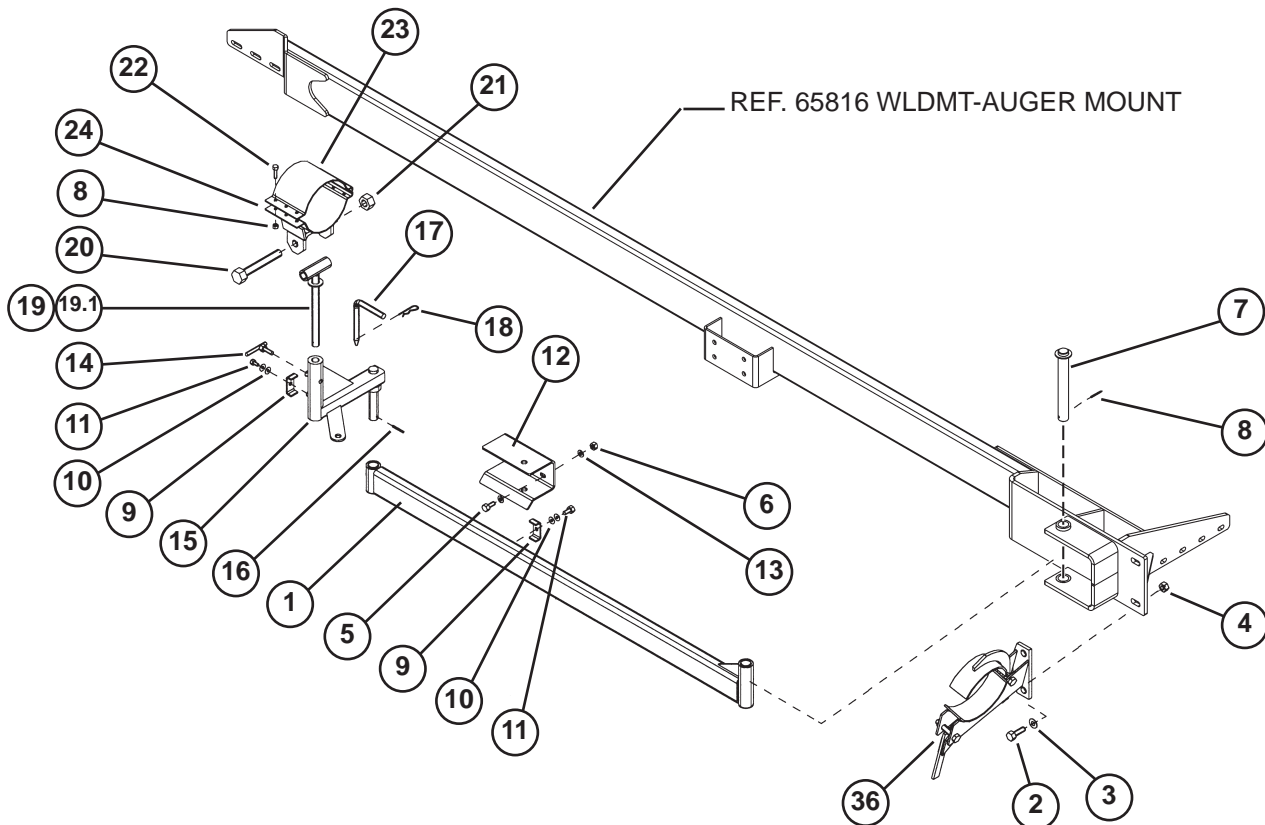

ASSY-AUGER MOUNTING COMPONENTS (8"/10")

Ref.	Part No.	Description	Qty.
1	65462	WLDMT-LONG AUGER MOUNT PAINTED	1
2	1011623	BOLT-HEX: .63 X 2.00 NC GR5 ZP	2
3	1013024	WASHER-FLAT: .63 ZP	4
4	1011578	NUT-HEX: .63 NC GR2 ZP	2
5	1011607	BOLT-HEX: .50 X 1.50 NC GR5 ZP	4
6	65313	NUT-NYLOCK: .50 NC GR2 ZP	10
7	65479	WLDMT-PIN	1
8	60965	PIN-ROLL: .19 X 1.50 ZP	1
9	50714	1023147 CLAMP 1/2" ZP	10
10	1011586	WASHER-LOCK: .38 ZP	3
11	1011600	BOLT-HEX: .38 X 1.00 NC GR5 ZP	3
12	65486	AUGER BRACKET-PAINTED	1
13	1014443	WASHER-FLAT: .50 ZP	10
14	65488	WLDMT-HANDLE	1
15	65468	WLDMT-ARM SHORT PAINTED	1
16	1011726	PIN-ROLL: .25 X 2.00 NP	2
17	65487	PIN-LOCK	1
18	1016115	PIN-HAIR: .19 X 3.25 ZP	1
19	65475	WLDMT-PIVOT TUBE	1
19.1	64505	GRIP-HANDLE RED 1" ID X 5.06" L	1
20	65721	BOLT-HEX: 1.00 X 7.00 NC GR5 ZP	1
21	65684	NUT-NYLOCK: 1.00 NC GR2 ZP	1
22	1011609	BOLT-HEX: .50 X 2.00 NC GR5 ZP	6
23	65909	CLAMP-TOP BRACKET: 8"	1
	66253	CLAMP-TOP BRACKET: 10"	1
24	65910	CLAMP-BOTTOM BRACKET: 8"	1
	66254	CLAMP-BOTTOM BRACKET: 10"	1
25	65911	ASSY-CLAMP: 8"	1
	66255	ASSY-CLAMP: 10"	1

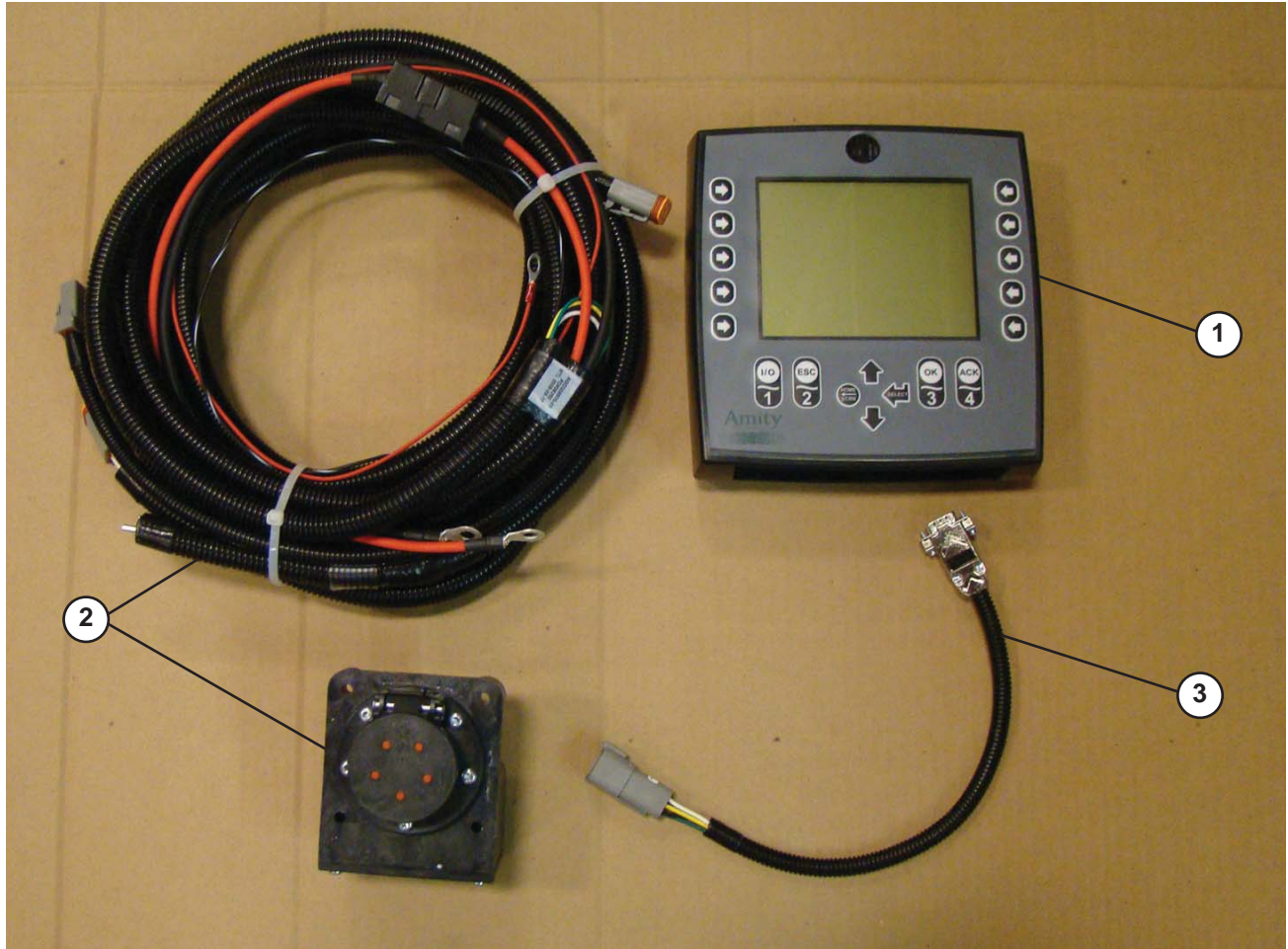

VIRTUAL TERMINAL CAB KIT

Ref.	Part No.	Description	Qty.
1	67086	MONITOR-D3030 ISO VIRTUAL MONITOR	1
2	34814	HARNESS-ISO TRACTOR GENERIC	1
3	34815	ADAPTER-AGTRON (D3030 ISO VT)	1

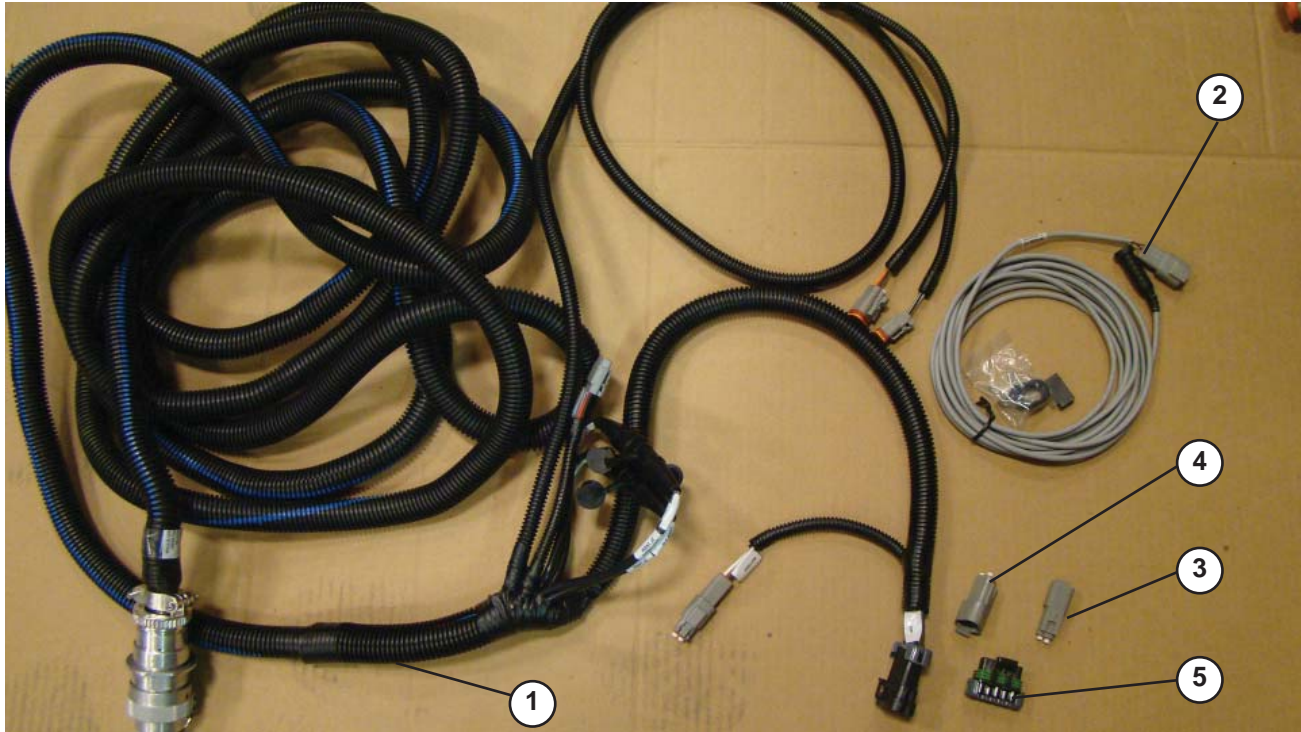

ISO BLOCKAGE/WORK SWITCH HARNESS KIT

Ref.	Part No.	Description	Qty.
1	67089	HARNESS-TOOLBAR ISO`	1
2	66508	SENSOR-WORK SWITCH (ISO)	1
3	35717	PLUG-2PIN DEUTSCH FEMALE	1
4	35718	PLUG-3PIN DEUTSCH FEMALE	1
5	35719	PLUG-10 PIN METRIPACK MALE	1
6	67087	HARNESS-TOOLBAR EXT. ISO 45' (NOT SHOWN)	1

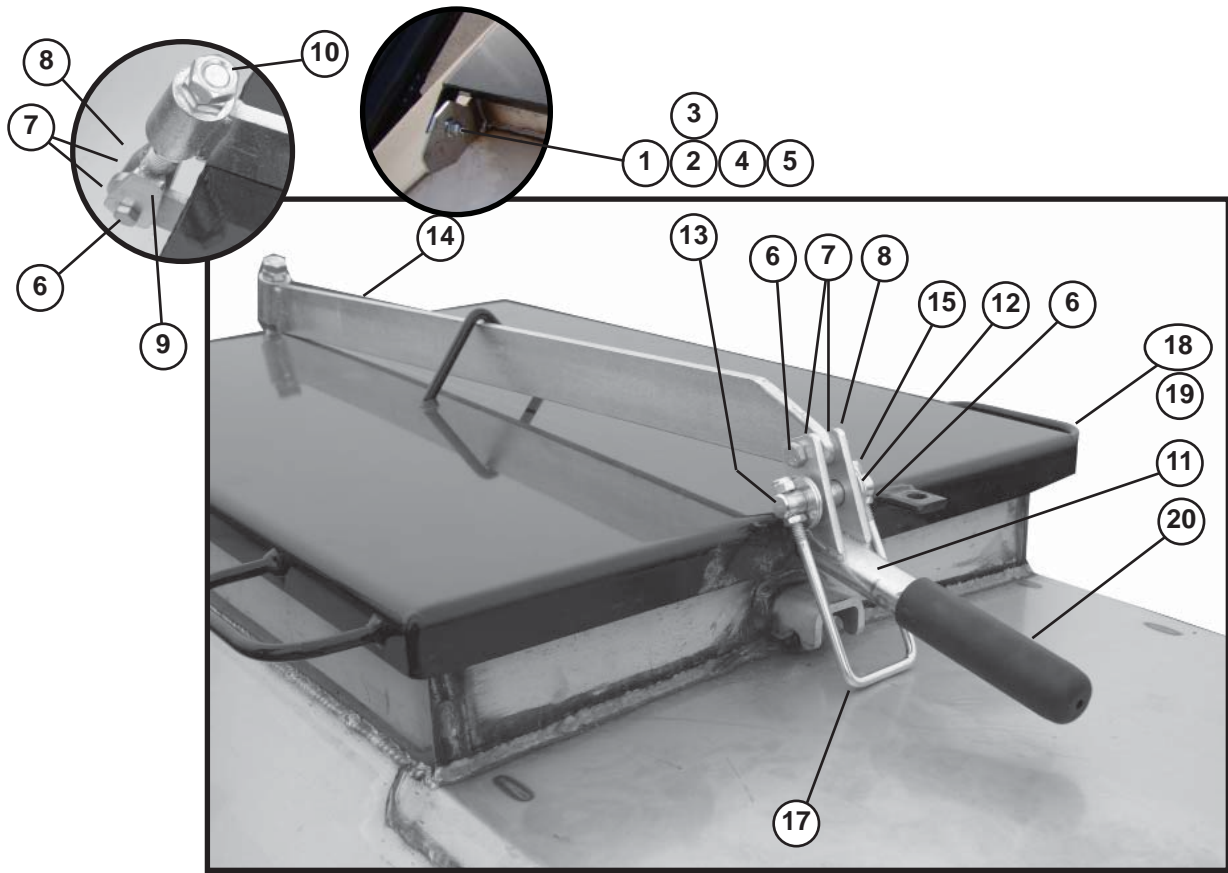

ASSY-DOORS

Ref.	Part No.	Description	Qty.
1	1017708	BOLT-HEX: .50 X 2.25 NC GR5 ZP	4
2	65555	TUBE-SPACER	4
3	65554	TUBE-SPACER 1.25 X .75 X .313L ZP	4
4	1011584	WASHER-FLAT: SAE .50 ZP	8
5	1011500	NUT-CENTERLOCK: .50 NC GR2 ZP	4
6	1011602	BOLT-HEX: .38 X 1.50 NC GR5 ZP	4
7	1013043	WASHER-FLAT: SAE .38 ZP	16
8	1011499	NUT-CENTERLOCK: .38 NC GR2 ZP	4
9	65556	ROD-ADJUSTMENT	2
10	1026259	NUT-JAM: .63 NC GR2 ZP	4
11	65557	WLDMT-CLAMP ADJ. TUBE	2
12	1013004	WASHER-FLAT: SAE .63 ZP	8
13	65560	PIN-CLAMP LEVER	2
14	65559	WLDMT-CLAMP LEVER 2	2
15	1024385	NUT-NYLOCK: .31 NC GR2 ZP	4
16	1020506	NUT-JAM: .31 NC GR2 ZP	4
17	65656	U-BOLT .313 X 5 X 2 X 5	2
18	65558	WLDMT-TOP DOOR	2
19	65722	GASKET-DOOR (NOT SHOWN)	2
20	65902	GRIP-BLACK 1" ID X 5.06" L	2
21	64504	SEALANT-PROGLAZE (NOT SHOWN)	100

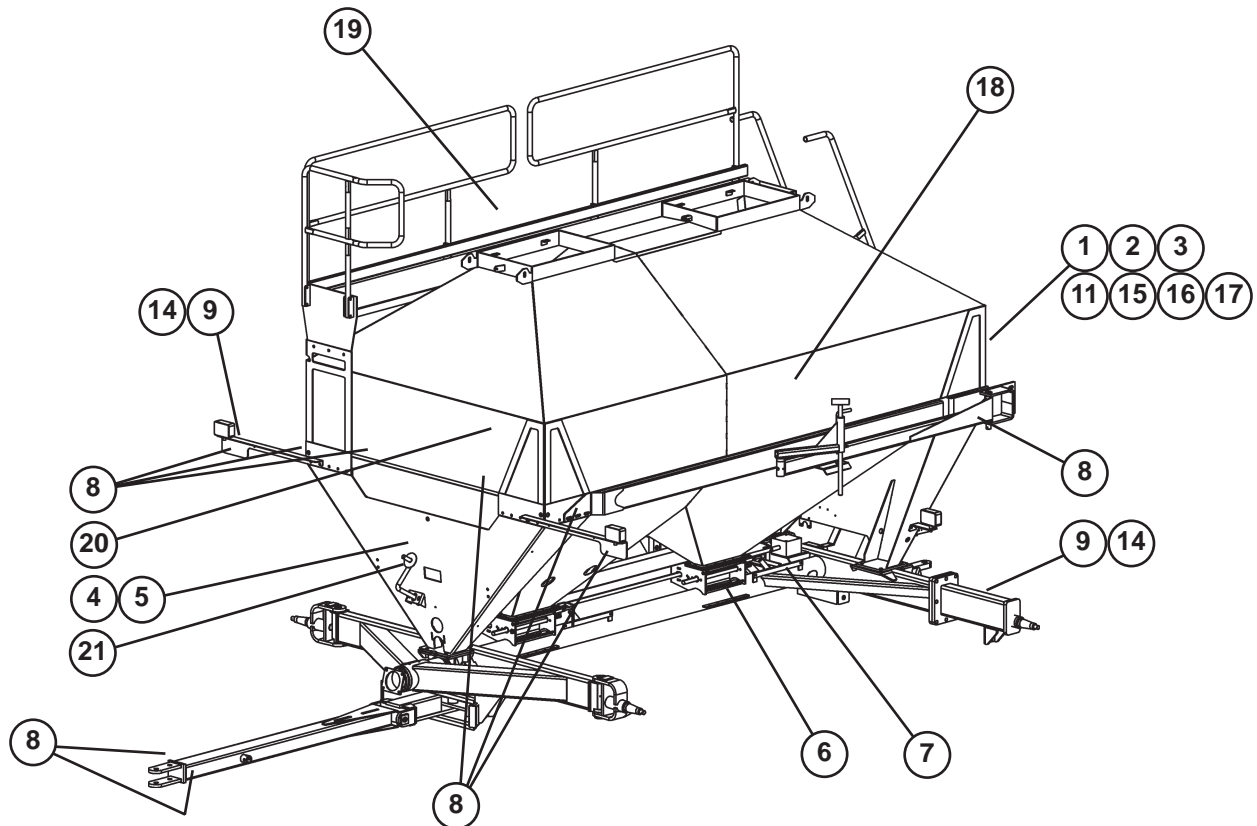

ASSY-DECALS AIR SYSTEM 2800 (3350)

Ref.	Part No.	Description	Qty.
1	65329	SIGN-SMV ASAE S276.5	1
2	1011595	BOLT-HEX: .25 X .75 NC GR5 ZP	2
3	1030946	NUT-TOPLOCK: .25 NC GR5 ZP	2
4	65641	DECAL-WARNING AVOID INJURY	1
5	65642	DECAL-DIRECTIONAL	1
6	65643	DECAL-WARNING DO NOT OPEN	2
7	65561	DECAL-INCH	2
8	65331	DECAL-YELLOW RETROREFLECTIVE	10
9	65330	DECAL-RED RETROREFLECTIVE	4
10	65644	DECAL-DANGER (SEE PAGE 52 - ASSY, AUGER & HYDRAULICS)	1
11	65645	DECAL-WARNING	1
12	65646	DECAL-WARNING (SEE PAGE 52 - ASSY, AUGER & HYDRAULICS)	1
13	65647	DECAL-DANGER (SEE PAGE 52 - ASSY, AUGER & HYDRAULICS)	1
14	65332	DECAL-RED ORANGE FLUORESCENT	4
15	65834	MOUNT-SMV SIGN	1
16	1011600	BOLT-HEX: .38 X 1.00 NC GR5 ZP	1
17	1013338	NUT-NYLOCK: .38 NC GR2 ZP	1
18	66515 (66517)	DECAL-AIR SYSTEM 2800 (3350) LH	1
19	66516 (66518)	DECAL-AIR SYSTEM 2800 (3350) RH	1
20	66080	DECAL-CRANK WHITE	1
21	66514	DECAL-FARGO AIRE	1

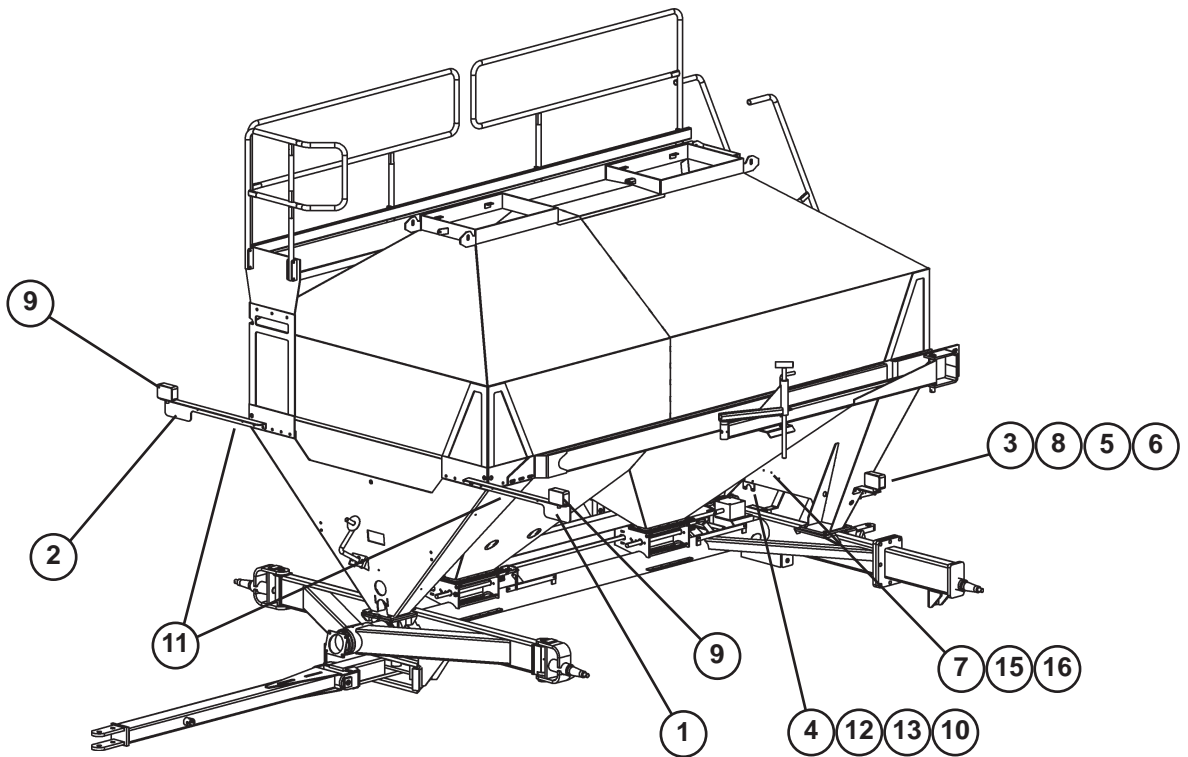

ASSY-SAFETY LIGHT

Ref.	Part No.	Description	Qty.
1	65831	BRACKET-LIGHT LH	1
2	65832	BRACKET-LIGHT RH	1
3	66011	BRACKET-LIGHT	2
4	65833	BRACKET-CONNECTOR 7 PIN	1
5	1033271	BOLT-HEX: .38 X 1.00 NC GR5 SS	4
6	1033268	NUT-NYLOCK: .38 NC GR2 SS	4
7	65341	MODULE-INTERFACE	1
8	65333	LAMP-RED TAIL	2
9	65334	LAMP-AMBER FLASHING	2
10	65340	HARNESS-SAFETY LIGHT S279.11	1
11	65354	HARNESS-LIGHT EXTENSION	2
12	1011598	BOLT-HEX: .31 X 1.00 NC GR5 ZP	4
13	1018693	NUT-NYLOCK: .31 NC GR2 ZP	4
14	1013122	TIE-CABLE, NYLON 14.00"	20
15	65839	SCREW-PAN HEAD: #10-24 NC X .75 LG	4
16	65348	NUT-HEX: #10-24 NC	4