

PARTS MANUAL

2026

3750 DEFOLIATOR

12 ROW 22

8 ROW 30

Amity
TECHNOLOGY



2800 7th Avenue North
Fargo, ND 58102

Phone: (701) 232-4199

Fax: (701) 234-1716

www.amitytech.com

TABLE OF CONTENTS

HITCH ASSEMBLY (68526).....	1-2
HITCH PACKAGE DEF (52145)	3-4
HOSE HOLDER (301131).....	5-6
DEPTH GAUGE (63367)	7-8
REVERSE FRONT SHIELD (68505)	9-10
FRONT PLASTIC ASSEMBLY (307318).....	11-12
DRIVE COMPONENTS (305606)	13-14
DRIVE/TUBE COMPONENTS (305605)	15-18
SIDE DOOR ASSEMBLY (305232).....	19-20
TOP DOOR KIT (305693)	21-22
TOP DOOR ASSEMBLY (307566)	23-24
REAR FLAP (52105)	25-26
MAINFRAME HYD MOUNTING (305337).....	27-28
LIGHT KIT (305609)	29-30
MANUAL STORAGE CASE (64643).....	31-32
WEIGHT KIT (305799)	33-34
AHC/FLOATING STRUT VALVE MOUNT (307016)	35-36
DECALS (305688)	37-40
FRONT DRUM 8R30 (305545).....	41-42
FALSE WALL 8R30 (305780).....	43-44
FRONT DRUM 12R22 (305521).....	45-46
#2 DRUM FLAILS	47-50
#3 DRUM FLAILS	51-68
STANDARD REAR STRUTS 11.2 X 24 22" (306001).....	69-70
STANDARD REAR STRUTS 11.2 X 24 44" (306002).....	71-72
STEERABLE REAR STRUTS 11.2 X 24 22" (305920).....	73-76
STEERABLE REAR STRUTS 11.2 X 24 44" (305921).....	77-80
STEERABLE STRUT ASSEMBLY (305924)	81-82
OSC STANDARD REAR STRUTS 11.2 X 24 44" (69449)	83-84
OFFSET STEERABLE REAR STRUTS 11.2 X 24 22" (306004)	85-88
STANDARD STEERING (305976).....	89-90
CENTERING STEERING (305996).....	91-92
ROWFINDER ASSEMBLY (306865)	93-96
ROWFINDER SCALPER MOUNT (306005/307539)	97-98
ROWFINDER FRAME MOUNT (306006/307540).....	99-100
REAR LIFT RATCHET JACK (307635)	101-102
REAR STRUT HYDRAULICS (306011)	103-104
AHC FRAME MOUNT (307248)	105-106
AHC SKID ASSEMBLY (306887).....	107-108
AHC BASE COMPONENTS (307380)	109-110
AHC ISOBUS CONTROLLER (307250).....	111-112
AHC/ADC JOYSTICK W/ MOUNT (303447).....	113-114
AHC SENSOR ASSEMBLY (307567)	115-116
AHC SENSOR KIT (306834)	117-118
AHC DEPTH GAUGE (306976)	119-120
AHC ELECTRICAL COMPONENTS	121-122
SCALPER BAR ASSEMBLY (306009/307545).....	123-124
SCALPER BASKETS (51475 & 307160)	125-128
STABILIZER WHEELS (305695/307546)	129-130
STABILIZER WHEELS W/ HYD (306734/307547)	131-132

(CONTINUED)

TABLE OF CONTENTS (CONTINUED)

CASTERING STABILIZER WHEELS W/ HYD (306735/307548) 133-134
SIDE LINER KIT (305777) 135-136
CYLINDER STOP KIT (51497)..... 137-138
REAR TIRE SCRAPERS (305779)..... 139-140
SCALPER LOCK UP KIT (307257)..... 141-142
JD GPS GUIDANCE MOUNTS (307875) 143-144
PTO CV 1-3/4" – 20 (305690)..... 145-146
PTO STD 1-3/4" – 20 (305691)..... 147-148
GEARBOX 1:25:1 L (305601) 149-150
GEARBOX 1:1 L W/ OVERRUN CLUTCH (305602)..... 151-152
GEARBOX 1:1.35 T (305603) 153-154
GEARBOX 1.93:1 T (305604) 155-156
SIDE DRIVELINE 1-3/8" – 1-3/8" (305611) 157-158
SIDE DRIVELINE 1-3/4" – 1-3/8" (305612) 159-160
U-JOINT COUPLER (68443) 161-162
HYDRAULIC COUPLER ASSEMBLY 163-164
SNAP RING PLIERS (69055) 165

HITCH ASSEMBLY (68526)

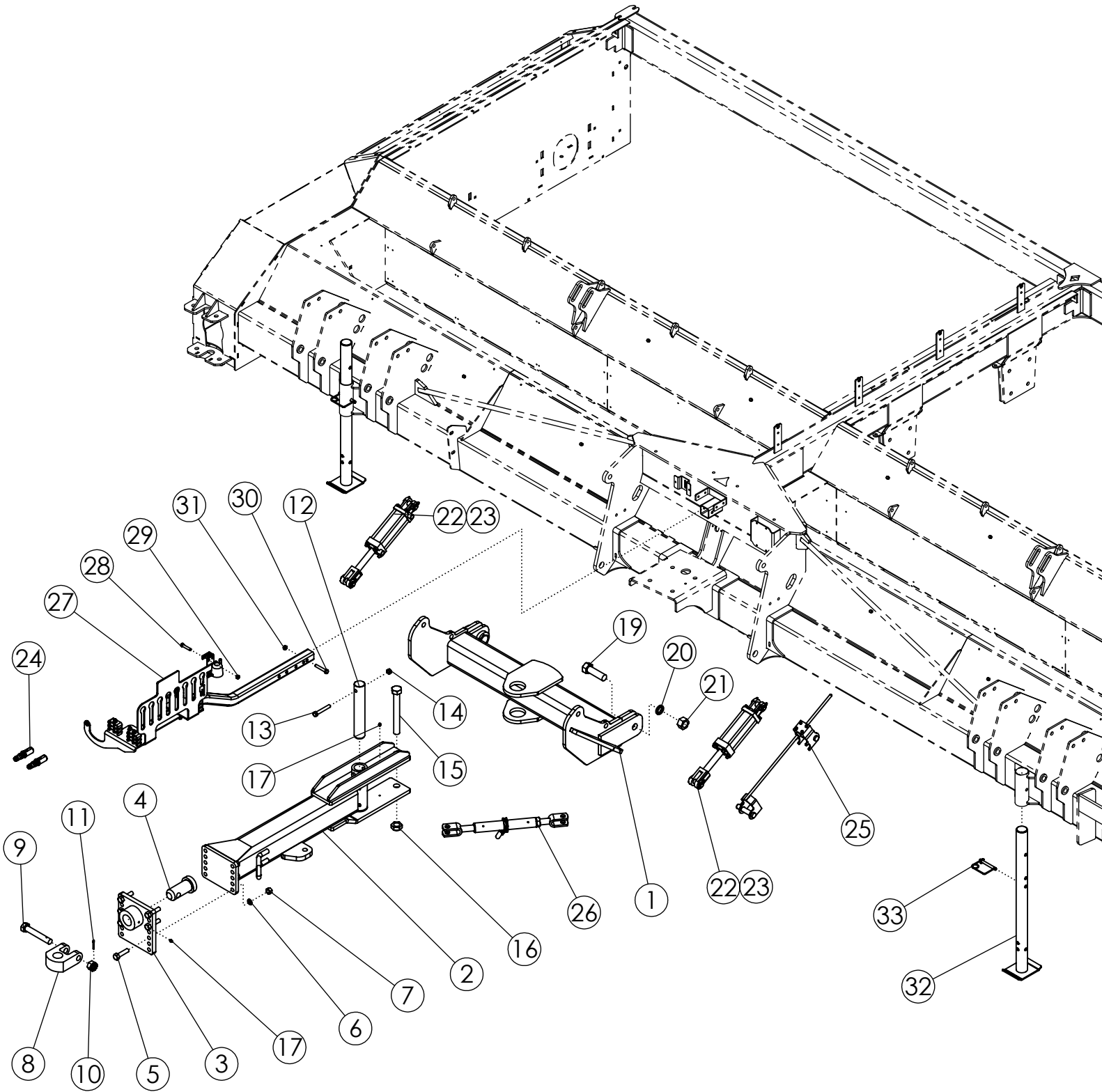

HITCH ASSEMBLY (68526)

ITEM	PART NO.	DESCRIPTION	QTY
1	50341	WLDMT-HITCH PIVOT 6R/8R STD	1
2	68277	WLDMT - DRAWPOLE DEF	1
3	57930	WLDMT-HITCH PLATE	1
4	62101	PIN-HITCH MACHINED ZP	1
5	1012059	BOLT-HEX: .75 X 3.00 NC GR5 ZP	6
6	1012061	WASHER-LOCK: .75 ZP	6
7	1011620	NUT-HEX: .75 NC GR2 ZP	6
8	64476	PLATE-PULL HITCH (2.065") PC	1
9	62477	BOLT-HITCH DRILLED	1
10	62088	NUT-SLOTTED: 1.125 NC GR5 ZP	1
11	1013473	PIN-COTTER: .19 X 2.00 ZP	1
12	50678	PIN	1
13	1015117	BOLT-HEX: .63 X 4.00 NC GR8 ZP	1
14	1016595	NUT-TOPLOCK: .63 NC GR5 ZP	1
15	1030756	BOLT-HEX: 1.25 X 10.50 NC GR5 ZP	1
16	1030759	NUT-TOPLOCK: 1.25 NC ZP	1
17	1011748	ZERK-GREASE .25 UNF STRAIGHT	5
18	58090	CHAIN-SAFETY 20200# (NOT SHOWN)	1
19	72021	BOLT-HEX: 1.38 X 4.50 NC GR5 ZP	2
20	1030760	WASHER-LOCK: 1.38 ZP	2
21	1030758	NUT-HEX: 1.38 NC GR2 ZP	2
22	58891	CYLINDER-HYDRAULIC 4 X 8" 3000	2
23	301315	SEAL KT-CYL 4 X 8, 4 X 10 3000PSI	
24	304186	ASSY-TRACTOR HYD COUPLERS (BLACK)	1
25	63367	ASSY-DEPTH GAUGE	1
26	52407	RATCHET JACK PAINTED BLACK	1
27	301131	ASSY-HYD HOSE HOLDER (PHANTOM)	1
28	1011616	BOLT-HEX: .44 X 2.25 NC GR5 ZP	1
29	1018706	NUT-TOPLOCK: .44 NC GR5 ZP	1
30	1011611	BOLT-HEX: .50 X 3.00 NC GR5 ZP	1
31	1027461	NUT-TOPLOCK: .50 NC GR5 ZP	1
32	52073	WLDMT-STAND	2
33	52408	SPRING PIN .50 X 3.50	2

HITCH PACKAGE DEF (52145)

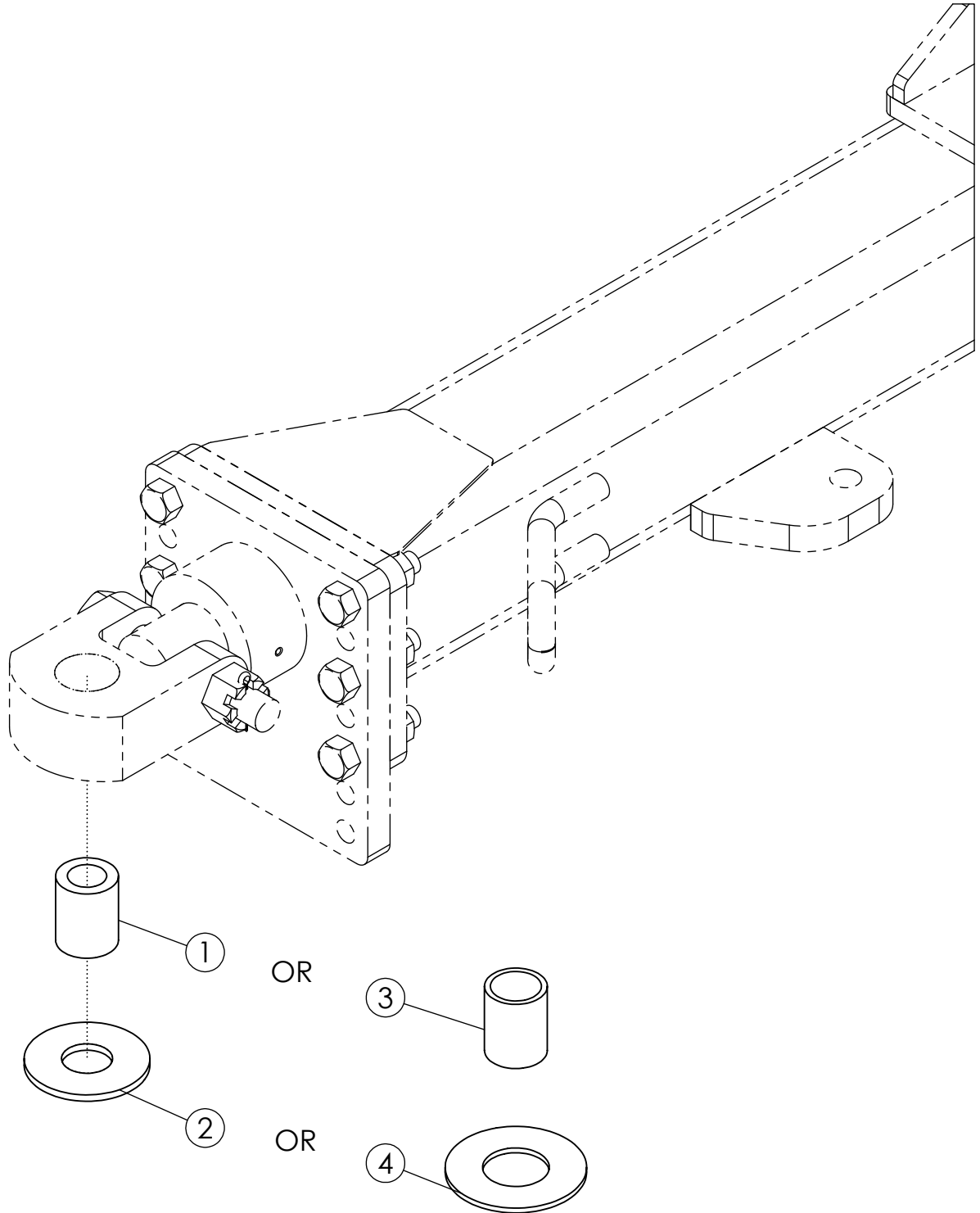

HITCH PACKAGE DEF (52145)

ITEM	PART NO.	DESCRIPTION	QTY
1	64615	TUBE-SPACER 2.0 X 1.25	1
2	58925	WASHER-HARDENED 4.000 X 1.625	1
3	64614	TUBE-SPACER	1
4	68645	WASHER-FLAT: 2.125 X 4.50 X .184	1

HOSE HOLDER (301131)

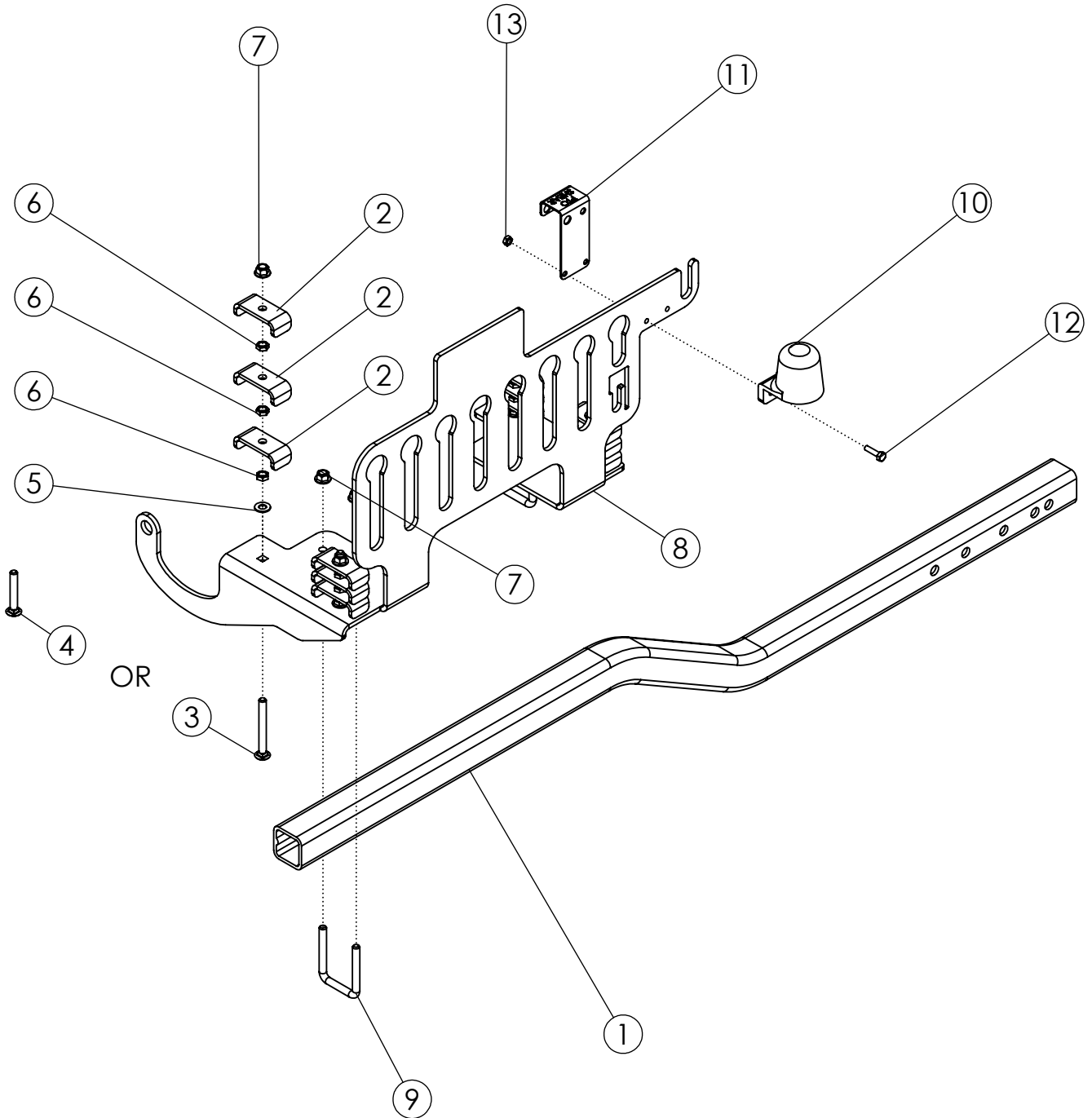

HOSE HOLDER (301131)

ITEM	PART NO.	DESCRIPTION	QTY
1	301135	TUBE-HYD HOSE HOLDER	1
2	50714	CLAMP 1/2" ZP	12
3	1030880	BOLT-CRG: .38 X 3.50 NC GR5 ZP	4
4	1030882	BOLT-CRG: .38 X 2.50 NC GR5 ZP	4
5	1014608	WASHER-FLAT: SAE .38 ZP	4
6	1013519	NUT-JAM: .38 NC GR2 ZP	12
7	303731	NUT-FLANGE: TOPLOCK .38 NC YZP	8
8	304215	PLATE-HOSE HOLDER (2025 - CURRENT)	1
9	33162	U-BOLT: .375 X 3 X 2 X 3	2
10	223329	HOLDER-LIGHT PLUG	1
11	307680	PLATE-PTO SHEAR SS	1
12	1013423	BOLT-HEX: .25 X 1.00 NC GR5 ZP	2
13	1030946	NUT-TOPLOCK: .25 NC GR5 ZP	2

DEPTH GAUGE (63367)

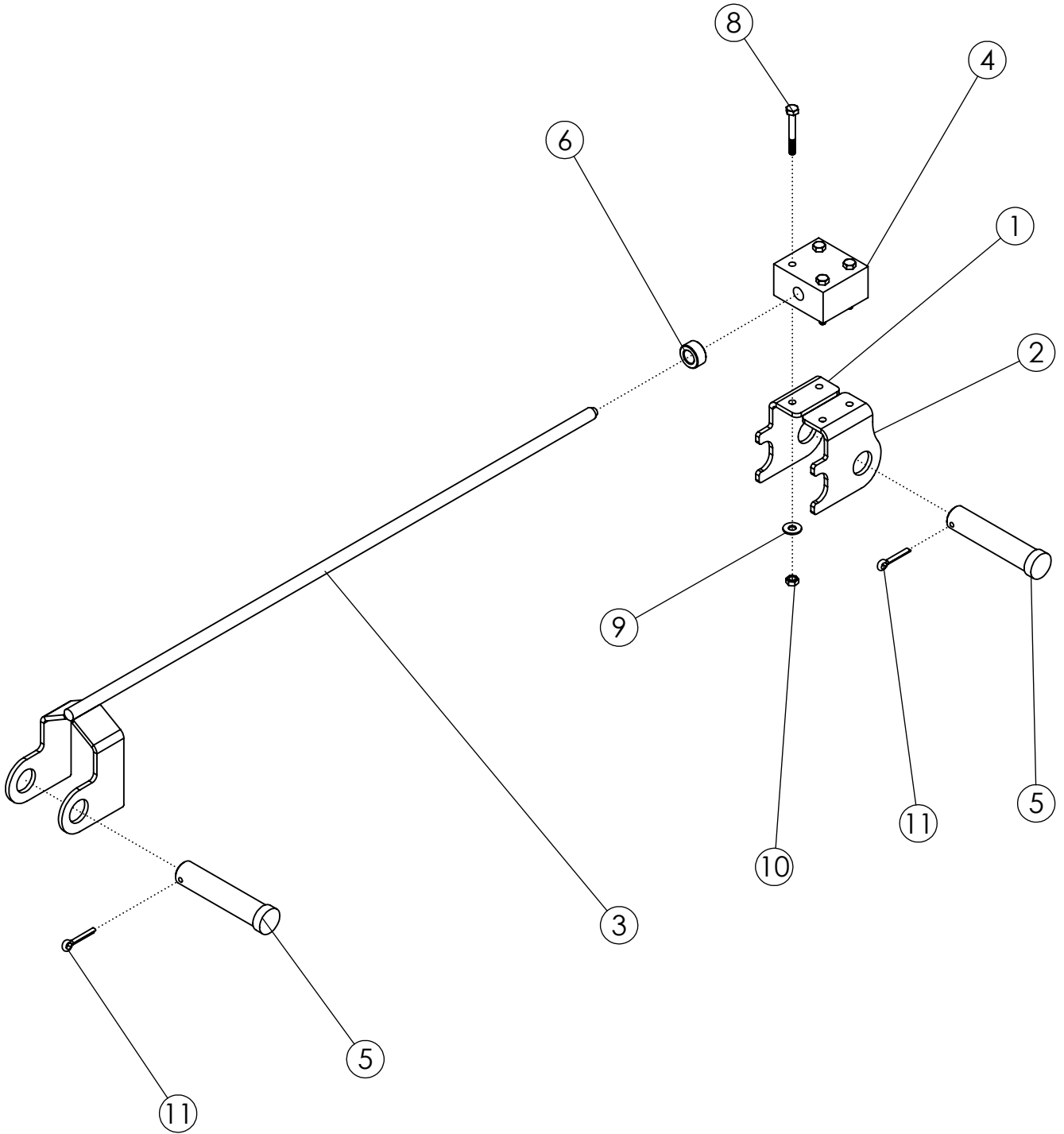

DEPTH GAUGE (63367)

ITEM	PART NO.	DESCRIPTION	QTY
1	63995	BRACKET-TOP RH	1
2	63996	BRACKET-TOP LH	1
3	63999	WLDMT-BOTTOM BRACKET ZP	1
4	63383	POLY GUIDE BLOCK	1
5	63406	PIN-CLEVIS: 1.00 X 4.00 ZP	2
6	63359	COLLAR-SET: 9/16 ZP	1
7	63405	DECAL-DEPTH GAUGE (NOT SHOWN)	1
8	1016211	BOLT-HEX: .25 X 2.00 NC GR5	4
9	1020416	WASHER-FLAT: .25 ZP	4
10	1030946	NUT-TOPLOCK: .25 NC GR5 ZP	4
11	1012375	PIN-COTTER .19 X 1.50 NP	2

REVERSE FRONT SHIELD (68505)

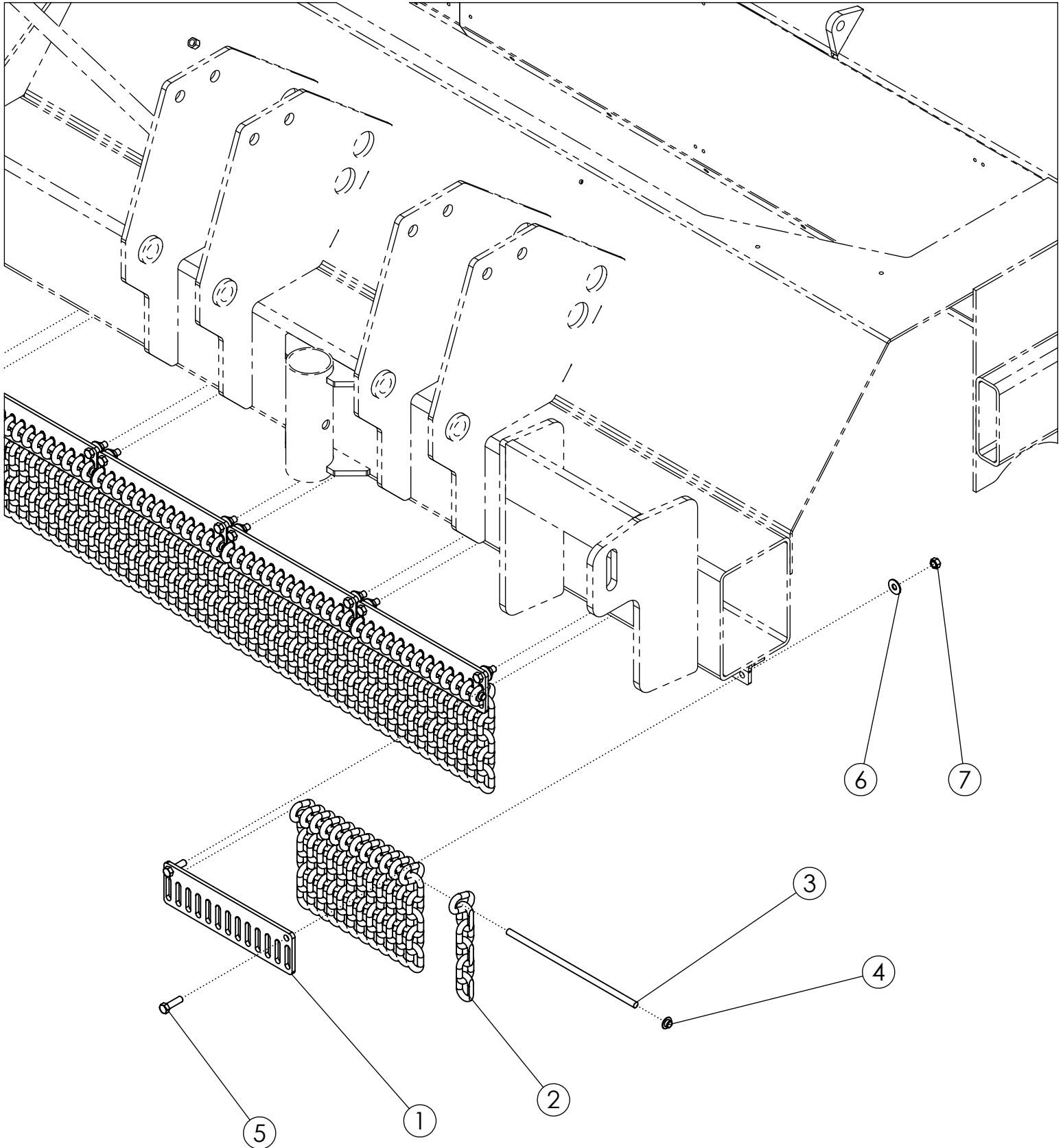

REVERSE FRONT SHIELD (68505)

ITEM	PART NO.	DESCRIPTION	QTY
1	307717	PLATE-CHAIN GUARD COMMON	24
2	307718	CHAIN-3/8" X 6 LINKS, GR30 ZP	312
3	307782	ROD-CHAIN RETAINER	24
4	307796	CAP-PUSH ON 3/8 STUD	24
5	1011601	BOLT-HEX: .38 X 1.25 NC GR5 ZP	48
6	65778	WASHER-FLAT: .38 SS	48
7	1016999	NUT-TOPLOCK: .38 NC GR5 ZP	48

FRONT PLASTIC ASSEMBLY (307318)

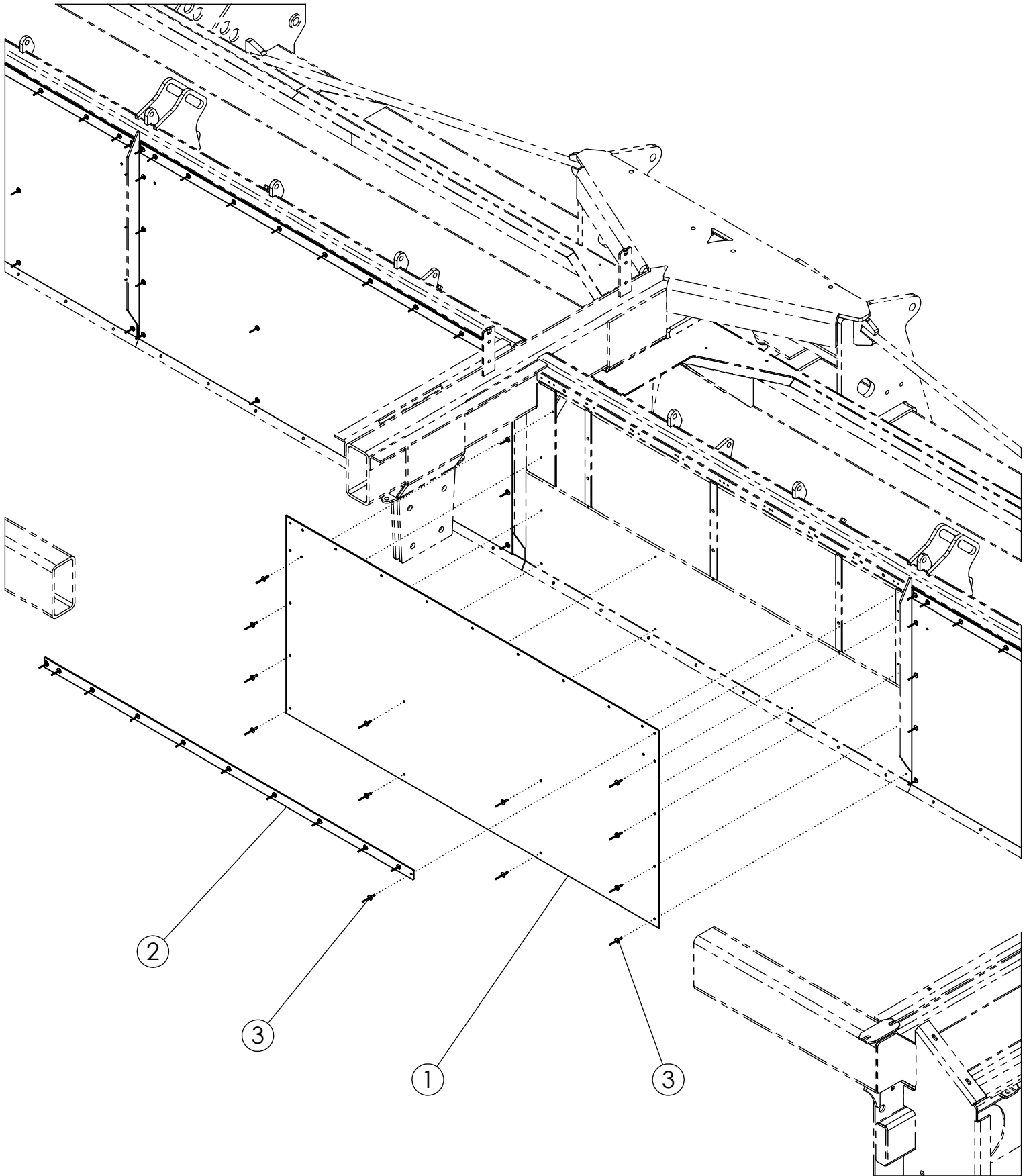

FRONT PLASTIC ASSEMBLY (307318)

ITEM	PART NO.	DESCRIPTION	QTY
1	305226	LINER-FRONT 12R (3750)	4
2	305227	BAR-LINER RETAINER 6R / 12R (3750)	4
3	56886	RIVET-POP: .19 X .675 ZP	92

DRIVE COMPONENTS (305606)

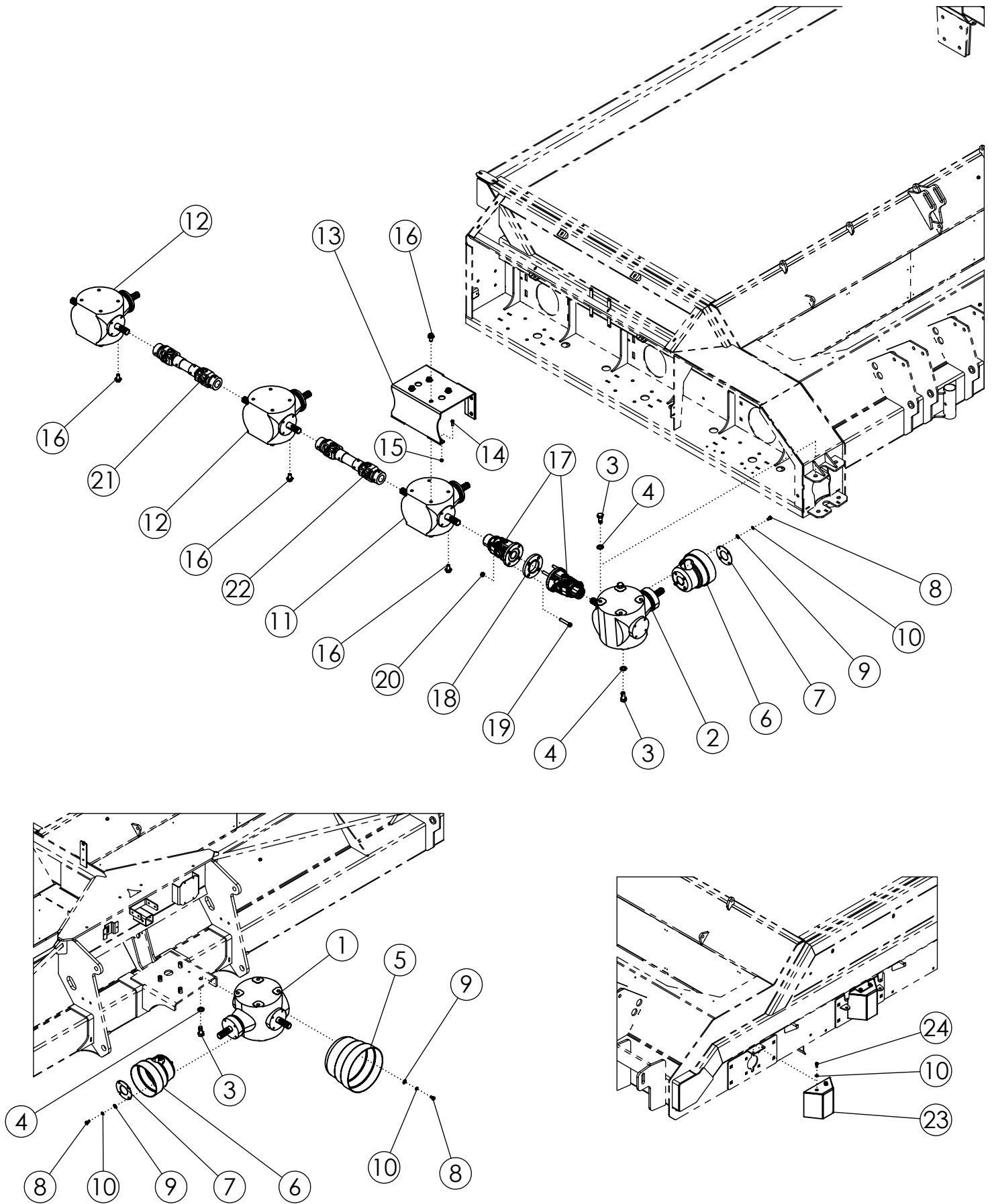

DRIVE COMPONENTS (305606)

ITEM	PART NO.	DESCRIPTION	QTY
1	305601	GEARBOX-S2155 1.25:1 L (BLACK)	1
2	305602	GEARBOX-S2155 1:1 L W/OVR RN CLU (BLACK)	1
3	305646	BOLT-HEX: M20 X 2.5 X L45 DIN 933-8.8	8
4	35132	WASHER-FLAT: SAE .75 YZP GR8	8
5	52389	SHIELD CONE-LARGE	1
6	63972	SHIELD-CONE SMALL DRILLED	2
7	306103	PLATE-RETAINER PTO SHIELD	2
8	68450	BOLT-HEX: M10 X 1.5 X L20 CL8.8 ZP	12
9	1011828	WASHER-FLAT: .38 ZP	12
10	1011586	WASHER-LOCK: .38 ZP	18
11	305603	GEARBOX-S2125 1:1.35 T (BLACK)	1
12	305604	GEARBOX-S2125 1:93:1 T (BLACK)	2
13	307313	WLDMT-GEARBOX BRACE	1
14	1011600	BOLT-HEX: .38 X 1.00 NC GR5 ZP	4
15	1016999	NUT-TOPLOCK: .38 NC GR5 ZP	4
16	306104	BOLT-FLG: M16 X 2.0 X L30 CL10.9 ZP NDP	16
17	68443	COUPLER-UNIVERSAL JOINT	1
18	305613	PLATE-SPACER COUPLER 90 DEG.	1
19	305192	BOLT-HEX: .56 X 3.00 NC GR5 ZP	4
20	59105	NUT-TOPLOCK: .56 NC GR8 ZP	4
21	305611	DRIVELINE-SIDE	1
22	305612	DRIVELINE-SIDE	1
23	68462	WLDMT-IDLER SHIELD	3
24	1011599	BOLT-HEX: .38 X .75 NC GR5 ZP	6
25	307568	ZERK-GREASE 45 DEG M6 (NOT SHOWN)	2

DRIVE/TUBE COMPONENTS - OUTSIDE (305605)

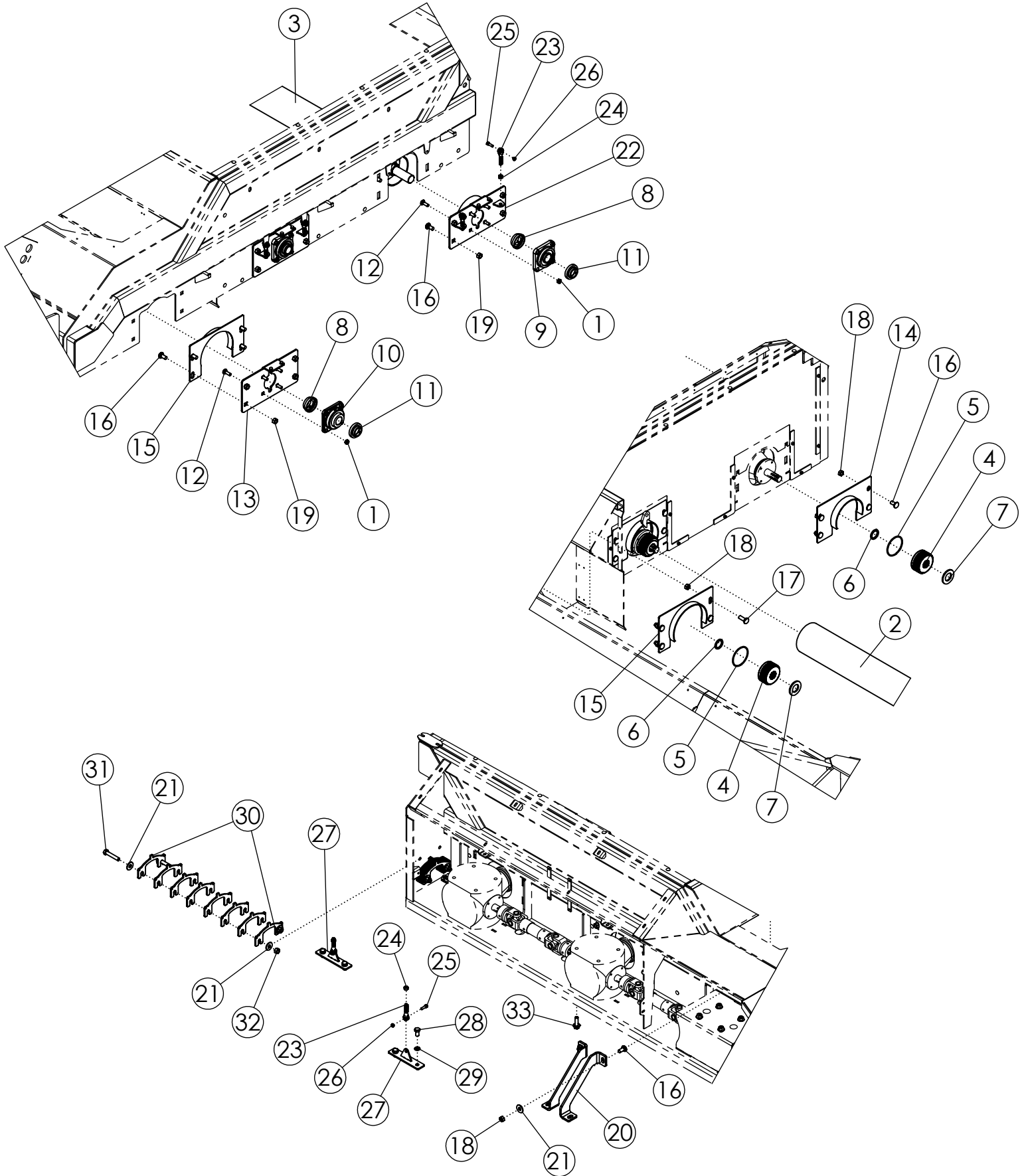

DRIVE/TUBE COMPONENTS - OUTSIDE (305605)

ITEM	PART NO.	DESCRIPTION	QTY
1	1027461	NUT-TOPLOCK: .50 NC GR5 ZP	12
2	68371	FLAIL TUBE-RH 1222 TT SCH 40 PAINTED	2
3	68375	FLAIL TUBE-LH 1222 TT SCH 40 PAINTED	2
4	68413	COUPLER-DRIVE	3
5	68414	O-RING-70 BUNA 4.1 X 2.1	3
6	68415	SNAP RING	3
7	306388	RUBBER-FLAIL TUBE SPACER	3
8	52382	SEAL PROTECTOR 1-3/4"	3
9	52404	BEARING-FLANGE 1-3/4"	2
10	306999	ASSY-BEARING-FLANGE 1-3/4" N-SEAL (STEEL)	1
11	52383	LOCK PROTECTOR 1-3/4"	3
12	1011660	BOLT-CRG: .50 X 1.50 NC GR5 ZP	12
13	307296	PLATE-DRUM BEARING MOUNT RED	1
14	51809	WLDMT-SHIELD ANTI WRAP (NARROW)	2
15	307290	WLDMT-8.5" ANTI-WRAP NARROW	2
16	72063	BOLT-CRG: .63 X 1.50 NC GR5 ZP	22
17	58635	BOLT-CRG: .63 X 2.00 NC GR5 ZP	4
18	1016595	NUT-TOPLOCK: .63 NC GR5 ZP	14
19	59316	NUT-CENTERLOCK: .625 NC GR5 ZP	12
20	68970	PLATE-GEARBOX SUPPORT	2
21	1013024	WASHER-FLAT: .63 ZP	10
22	305624	WLDMT-PLATE BEARING ADJ.	2
23	305614	BOLT-CLEVIS .5"	6
24	1013429	NUT-CENERLOCK: .50 NF GR5 ZP	6
25	1011601	BOLT-HEX: .38 X 1.25 NC GR5 ZP	6
26	1016999	NUT-TOPLOCK: .38 NC GR5 ZP	6
27	305617	WLDMT-GEARBOX LIFT	2
28	68449	BOLT-HEX: M 16 X 2.0 X L30 CL8.8 ZP	4
29	1011813	WASHER-LOCK: .63 ZP	4
30	305626	PLATE-GEARBOX SPACER PC	16
31	1014000	BOLT-HEX: .63 X 3.50 NC GR5 ZP	4
32	1011578	NUT-HEX: .63 NC GR2 ZP	4
33	306697	BOLT-FLG: M16 X 2.0 X L50 CL10.9 ZP	8

DRIVE/TUBE COMPONENTS - CENTER/FRONT (305605)

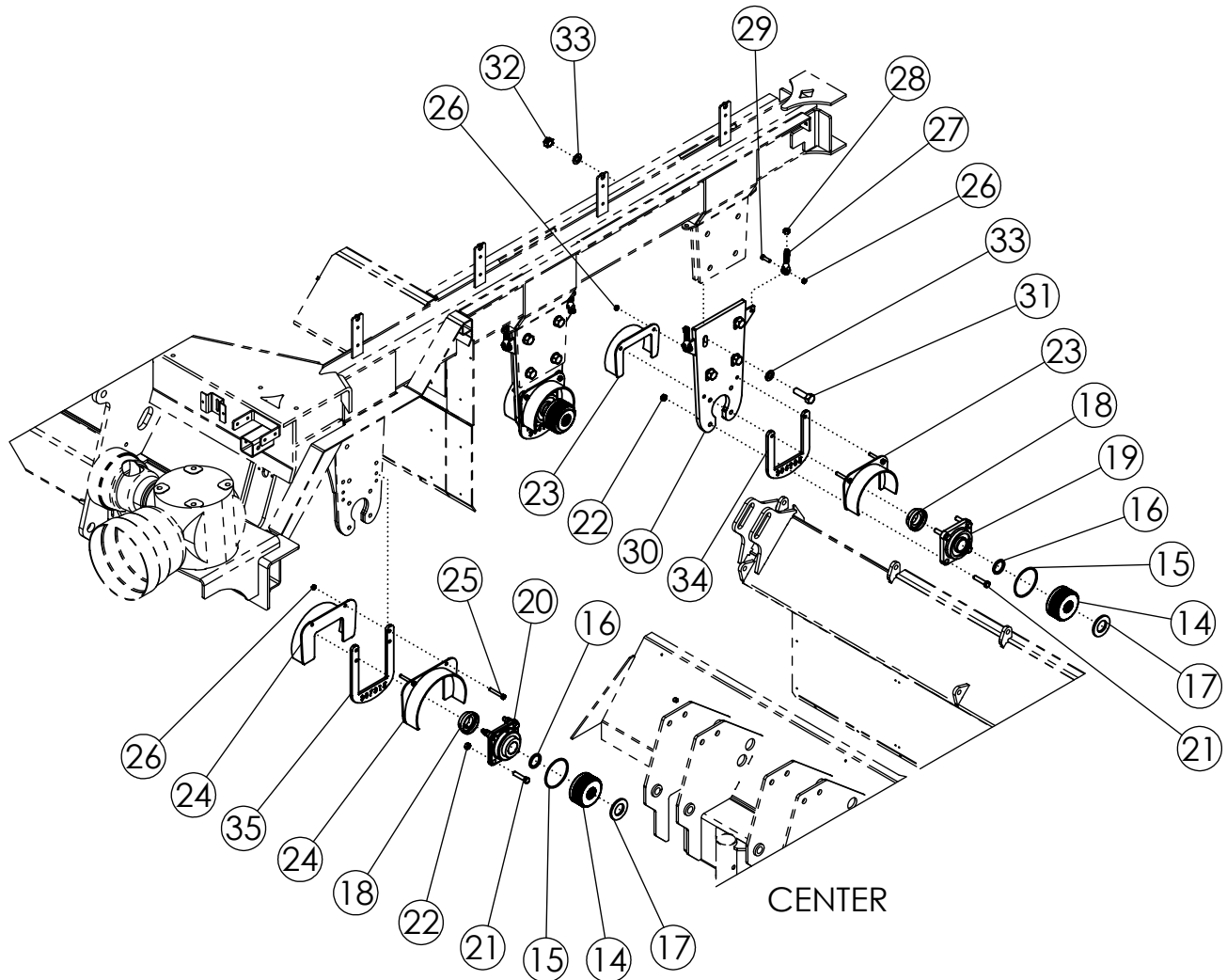
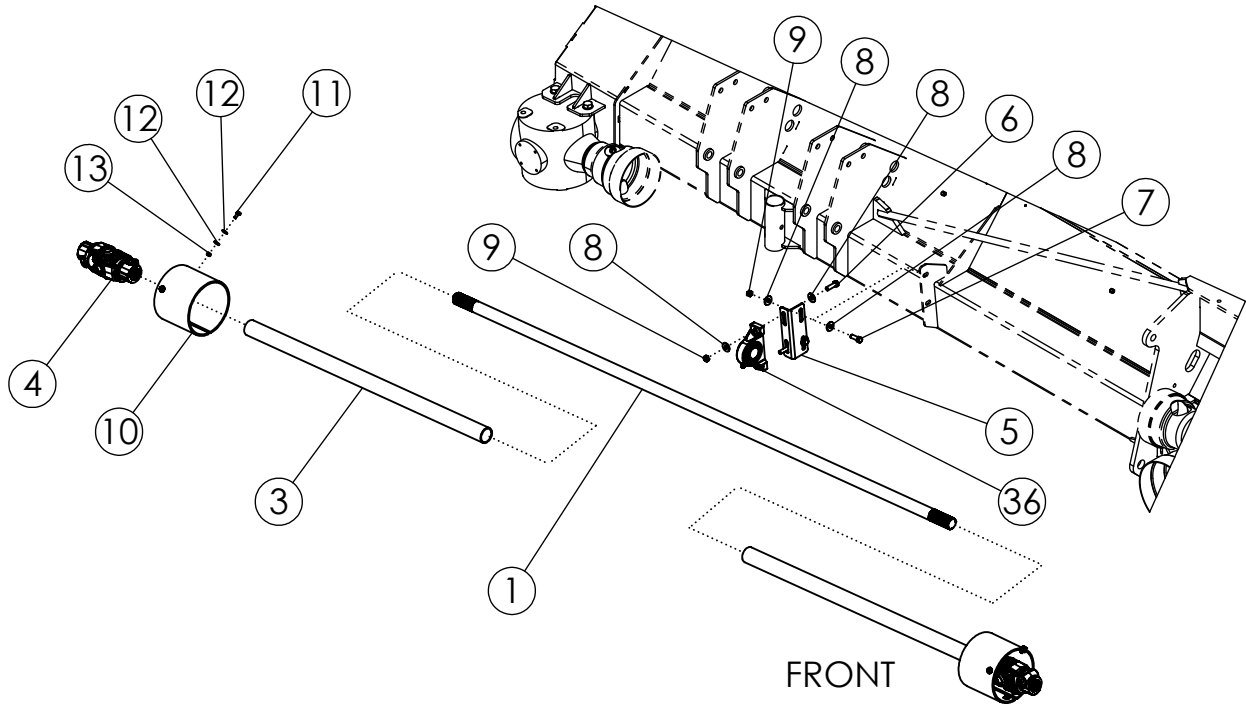

DRIVE/TUBE COMPONENTS - CENTER/FRONT (305605)

ITEM	PART NO.	DESCRIPTION	QTY
1	305699	SHAFT-CROSS 12R SPLINED	1
2	307568	ZERK-GREASE 45 DEG M6 (NOT SHOWN)	2
3	68275	COVER-CROSS SHAFT 49"	2
4	69683	UNIVERSAL JOINT 1-3/4"-20 SPLINED	2
5	305243	PLATE-BEARING SUPPORT	1
6	1011608	BOLT-HEX: .50 X 1.75 NC GR5 ZP	2
7	1011607	BOLT-HEX: .50 X 1.50 NC GR5 ZP	2
8	1014443	WASHER-FLAT: .50 ZP	8
9	1027461	NUT-TOPLOCK: .50 NC GR5 ZP	4
10	52372	FLAP-RUBBER-INSERT	2
11	1011597	BOLT-HEX: .31 X .75 NC GR5 ZP	8
12	1011583	WASHER-FLAT: .31 ZP	16
13	1030700	NUT-TOPLOCK: .31 NC GR5 ZP	8
14	68413	COUPLER-DRIVE	3
15	68414	O-RING-70 BUNA 4.1 X 2.1	3
16	68415	SNAP RING	3
17	306388	RUBBER-FLAIL TUBE SPACER	3
18	52382	SEAL PROTECTOR 1-3/4"	3
19	52404	BEARING-FLANGE 1-3/4"	2
20	306999	ASSY-BEARING-FLANGE 1-3/4" N-SEAL (STEEL)	1
21	67146	BOLT-HEX: .50 X 2.25 NC GR8 ZP	12
22	36233	NUT-TOPLOCK: .50 NC GR8 ZP	12
23	305465	WLDMT-ANTI WRAP	4
24	307293	WLDMT-8.5" ANTI WRAP WIDE	2
25	1015174	BOLT-HEX: .38 X 2.50 NC GR5 ZP	6
26	1016999	NUT-TOPLOCK: .38 NC GR5 ZP	10
27	305614	BOLT-CLEVIS .5"	4
28	1013429	NUT-CENERLOCK: .50 NF GR5 ZP	4
29	1011601	BOLT-HEX: .38 X 1.25 NC GR5 ZP	4
30	305709	WLDMT-HANGER	2
31	1016598	BOLT-HEX: .75 X 2.50 NC GR5 ZP	8
32	1013537	NUT-CENTERLOCK: .75 NC ZP	8
33	1012634	WASHER-FLAT: SAE .75 ZP	16
34	306985	PLATE-DRUM CATCH	2
35	307315	PLATE-DRUM FAILURE CATCH 2.0	1
36	52405	BEARING-PILLOW 1-3/4"	1

SIDE DOOR ASSEMBLY (305232)

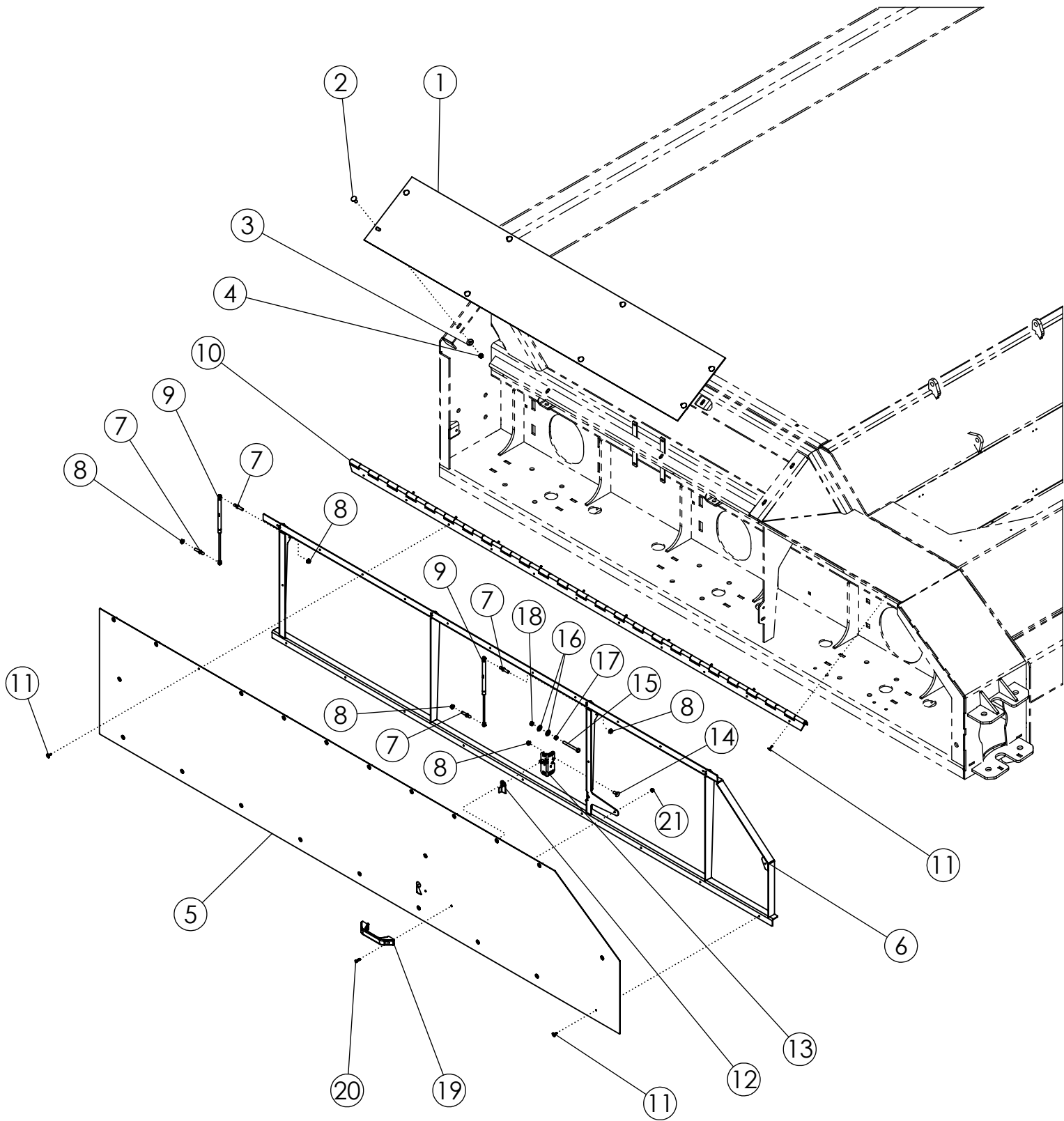

SIDE DOOR ASSEMBLY (305232)

ITEM	PART NO.	DESCRIPTION	QTY
1	305233	SHEET-TOP SHIELD	1
2	59488	BOLT-CRG: .38 X 1.00 NC GR5 ZP	8
3	1011828	WASHER-FLAT: .38 ZP	8
4	1016999	NUT-TOPLOCK: .38 NC GR5 ZP	8
5	305234	SHEET-SIDE DOOR 12R	1
6	305235	WLDMT-DOOR FRAME 12R	1
7	69278	STUD-BALL 5/16-18 NC X .75	4
8	67077	NUT-FLANGE SERR .31 NC ZP GR2	6
9	305225	SPRING-GAS SHOCK 150LB 8" STROKE	2
10	305224	HINGE - 96 HEAVY CONTINUOUS	1
11	1011974	RIVET-POP: .19 X .55 ZP	34
12	69284	LEVER-HRV LATCH ZP	1
13	69283	LATCH-ROTARY	1
14	65702	BOLT-CRG: .31 X .75 NC GR5 ZP	2
15	1029448	BOLT-HEX .31 X 3.00 NC GR5 ZP	1
16	1011583	WASHER-FLAT: .31 ZP	2
17	1011575	NUT-HEX: .31 NC GR2 ZP	1
18	1030700	NUT-TOPLOCK: .31 NC GR5 ZP	1
19	69285	HANDLE-MOLDED GRAB	1
20	67078	SCREW-P-H: 10-24 X .75 NC GR2 ZP	2
21	1026591	NUT-K-LOCK: #10-24 NC GR2 ZP	2

TOP DOOR KIT (305693)

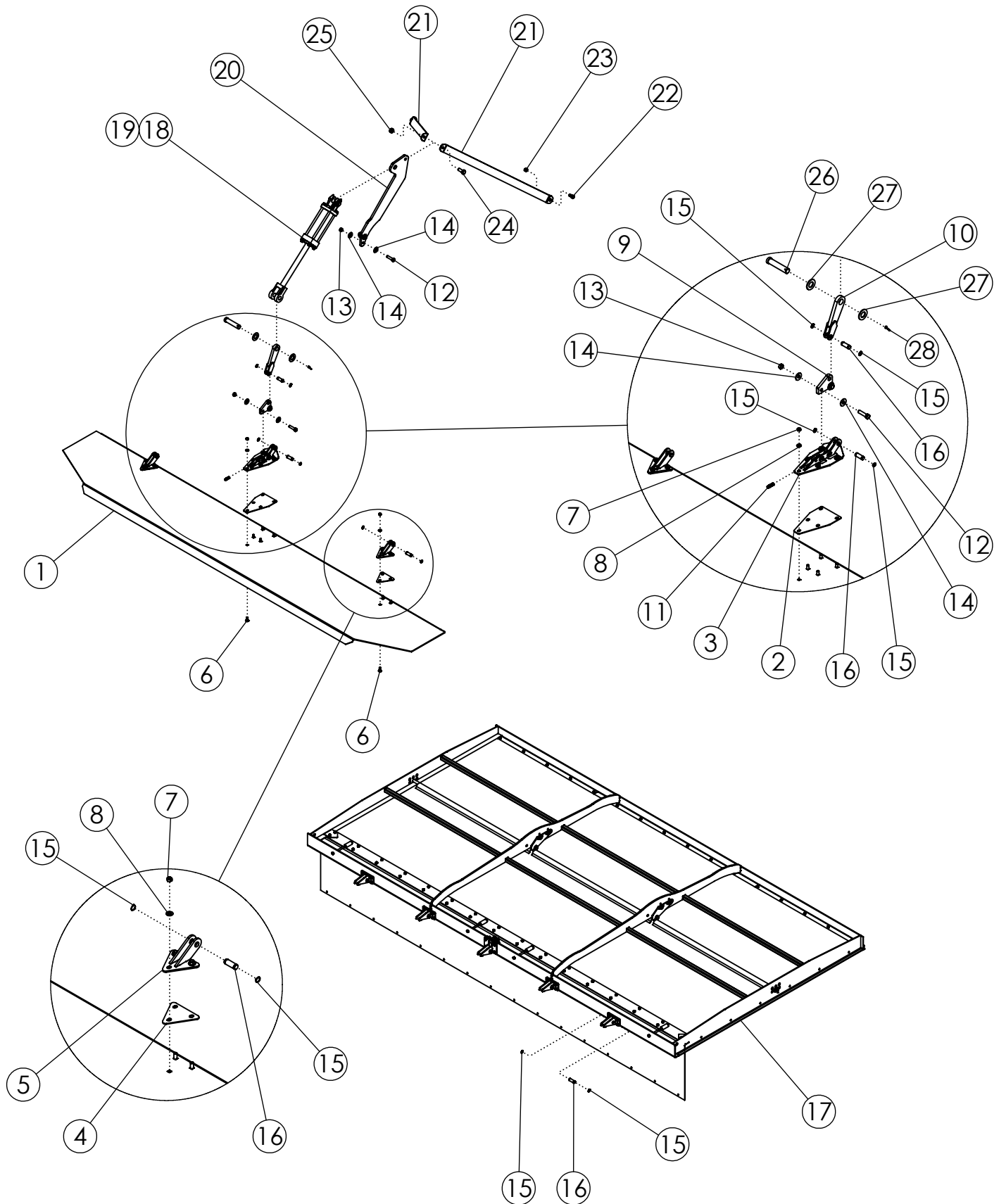

TOP DOOR KIT (305693)

ITEM	PART NO.	DESCRIPTION	QTY
1	305769	PLATE-SHROUD DOOR	2
2	306089	PLATE-SPACER CENTER	2
3	306085	WLDMT-HINGE CENTER	2
4	306090	PLATE-SPACER OUTER	4
5	305655	WLDMT-HINGE SHROUD DOOR	4
6	59488	BOLT-CRG: .38 X 1.00 NC GR5 ZP	22
7	1016999	NUT-TOPLOCK: .38 NC GR5 ZP	22
8	1014608	WASHER-FLAT: SAE .38 ZP	22
9	305771	PLATE-HINGE LUG	2
10	305629	WLDMT-DOOR LINKAGE	2
11	1029784	SCREW SET 3/8-16 X 1.5	2
12	1011609	BOLT-HEX: .50 X 2.00 NC GR5 ZP	8
13	1027461	NUT-TOPLOCK: .50 NC GR5 ZP	8
14	1014443	WASHER-FLAT: .50 ZP	16
15	305261	SNAP-RING .625" HD EXTERNAL ZP	36
16	305244	PIN-TOP DOOR ZP	18
17	307566	ASSY-TOP DOOR 12R (3750)	2
18	58890	CYLINDER-HYDRAULIC 3 X 8" 3000	2
19	301314	SEAL KT-CYL 3 X 8 3000PSI	
20	307805	PLATE-DOOR CYLINDER LIFT	2
21	305254	PLATE-LIFT STRAP	4
22	1011096	BOLT-HEX: .50 X 1.00 NC GR5 ZP	4
23	1011500	NUT-CENTERLOCK: .50 NC GR2 ZP	4
24	1014349	BOLT-HEX: .63 X 1.50 NC GR5 ZP	2
25	59316	NUT-CENTERLOCK: .625 NC GR5 ZP	2
26	63406	PIN-CLEVIS: 1.00 X 4.00 ZP	2
27	1016663	WASHER-FLAT: SAE 1.00 ZP	4
28	1012375	PIN-COTTER .19 X 1.50 ZP	2

TOP DOOR ASSEMBLY (307566)

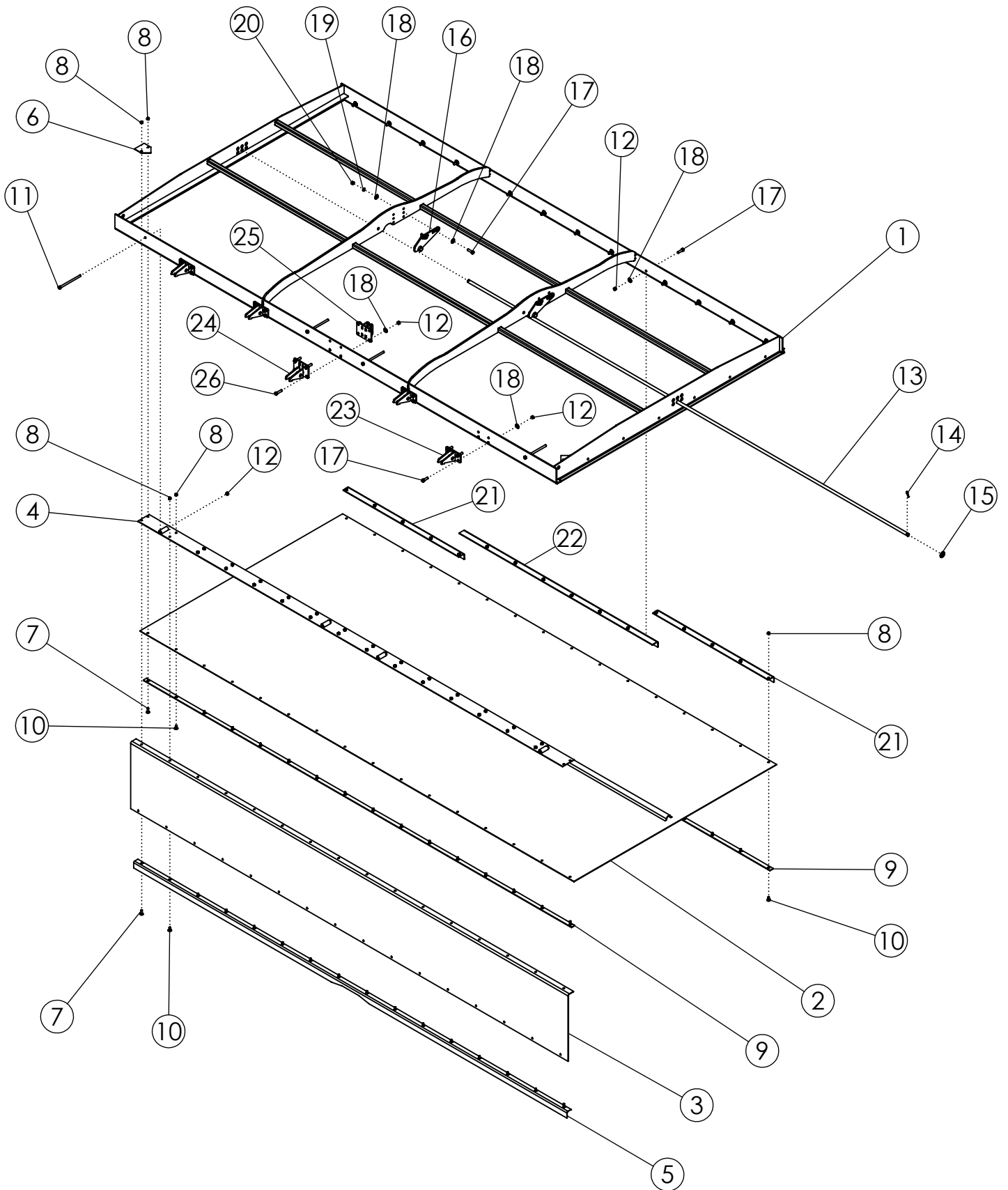

TOP DOOR ASSEMBLY (307566)

ITEM	PART NO.	DESCRIPTION	QTY
1	307760	WLDMT-12R TOP DOOR, TARP	1
2	306966	TARP-12R TOP DOOR	1
3	307554	TARP-12R FRONT SHORT	1
4	306645	WLDMT-TENSION	1
5	307804	PLATE-TENSION LOWER	1
6	307535	PLATE-TARP DOOR CLAMP	2
7	1017255	BOLT-CRG: .31 X 1.00 NC GR5 ZP	4
8	1030700	NUT-TOPLOCK: .31 NC GR5 ZP	48
9	306622	PLATE-REAR TARP CLAMP	2
10	65702	BOLT-CRG: .31 X .75 NC GR5 ZP	44
11	34925	BOLT-HEX: .38 X 6.00 NC GR5 ZP	4
12	1016999	NUT-TOPLOCK: .38 NC GR5 ZP	38
13	306713	ROD-12R TARP SUPPORT	1
14	1012375	PIN-COTTER .19 X 1.50 NP	2
15	1013004	WASHER-FLAT: SAE .63 ZP	2
16	307310	WLDMT-TARP ROD ADJ	2
17	1011601	BOLT-HEX: .38 X 1.25 NC GR5 ZP	34
18	1011828	WASHER-FLAT: .38 ZP	42
19	1011586	WASHER-LOCK: .38 ZP	4
20	1011576	NUT-HEX: .38 NC GR2 ZP	4
21	307766	PLATE-BOLT RAIL REAR SIDE	2
22	307767	PLATE-BOLT RAIL CENTER	1
23	307806	WLDMT-DOOR HINGE PIVOT COMMON	4
24	307807	WLDMT-DOOR HINGE CENTER PIVOT	1
25	307808	WLDMT-DOOR HINGE CENTER PIVOT	1
26	1011602	BOLT-HEX: .38 X 1.50 NC GR5 ZP	4

REAR FLAP (52105)

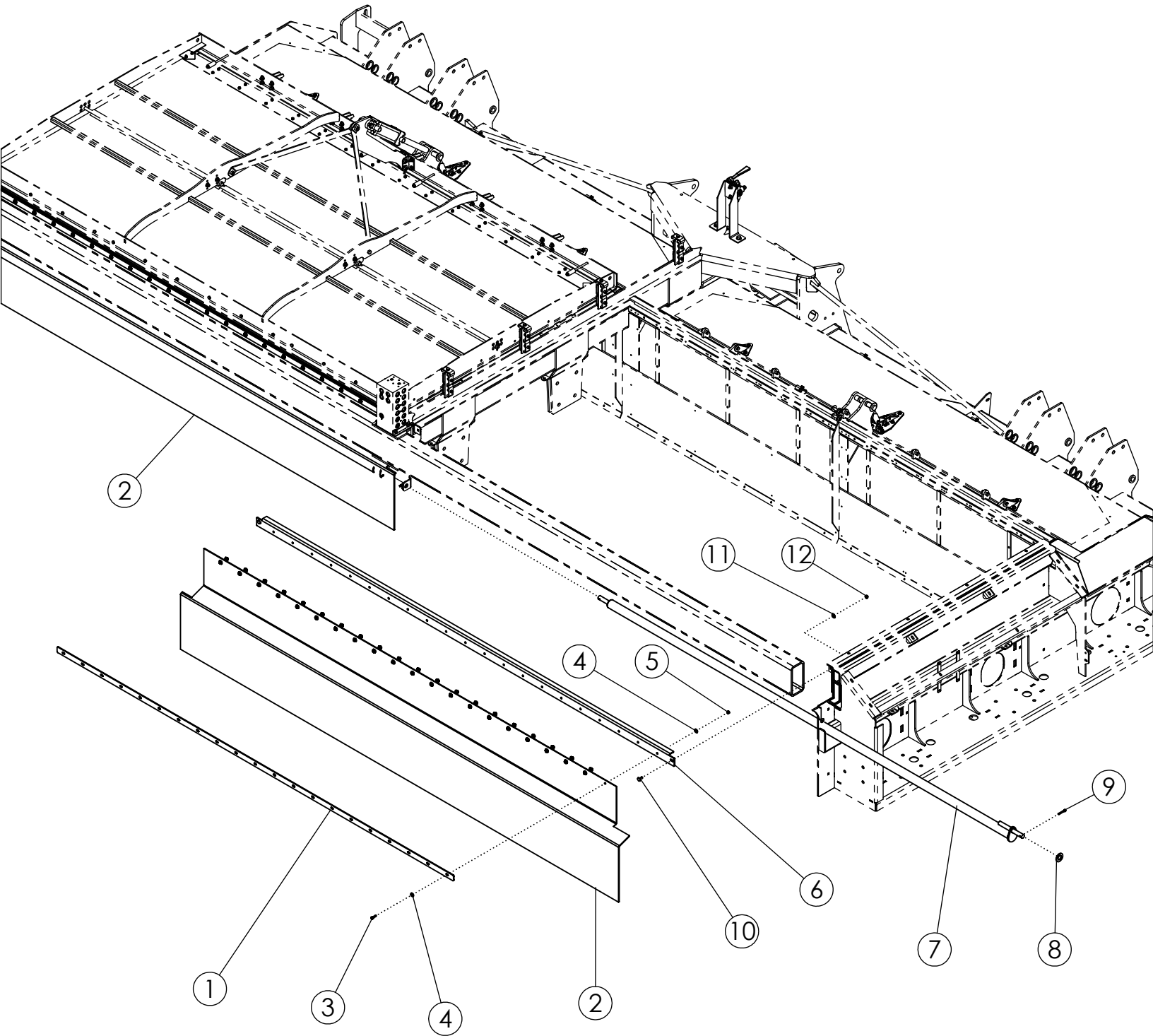

REAR FLAP (52105)

ITEM	PART NO.	DESCRIPTION	QTY
1	307661	BAR-REAR FLAP 1222 ('24-CURR)	2
2	307654	FLAP-LARGE REAR (12R22)	2
3	1011598	BOLT-HEX: .31 X 1.00 NC GR5 ZP	42
4	1011583	WASHER-FLAT: .31 ZP	84
5	1030700	NUT-TOPLOCK: .31 NC GR5 ZP	42
6	307655	PLATE-REAR SUPPORT 12R ('24-CURRENT)	2
7	307853	WLDMT-REAR FLAP HOLDER 12R	2
8	1016663	WASHER-FLAT: SAE 1.00 ZP	4
9	1016944	PIN-COTTER: .25 X 2.00 ZP	4
10	59488	BOLT-CRG: .38 X 1.00 NC GR5 ZP	4
11	1011828	WASHER-FLAT .38 ZP	4
12	1016999	NUT-TOPLOCK: .38 NC GR5 ZP	4

MAINFRAME HYD MOUNTING (305337)

PLUGS (ITEM 16)
USED AS REQUIRED

THE REST OF THE MAINFRAME
HYDRAULIC COMPONENTS
(FITTINGS, CLAMPS, VALVES, ETC.)
LISTED IN SPECIFIC HYDRAULIC
CONFIGURATION MANUALS

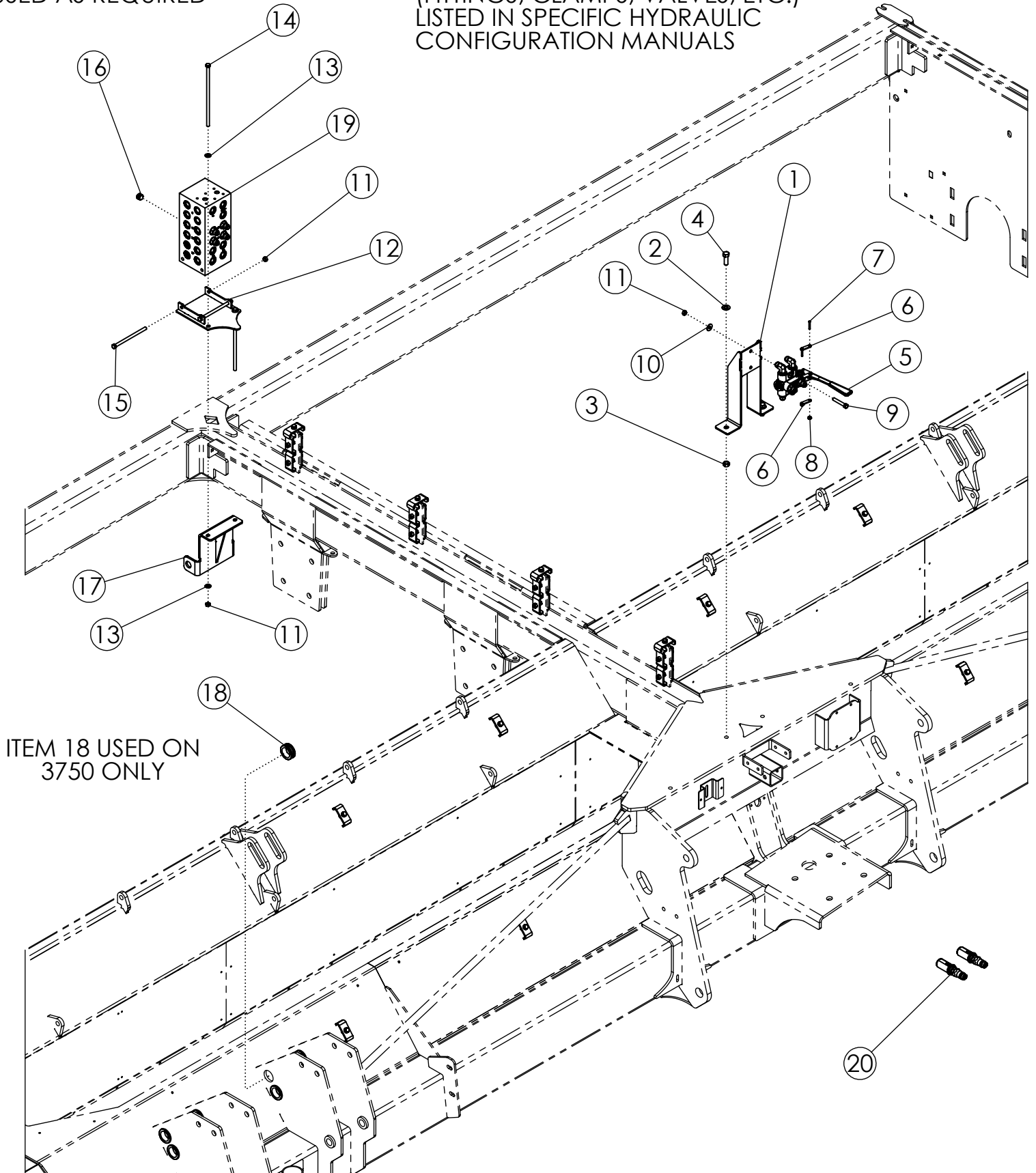

ITEM 18 USED ON
3750 ONLY

MAINFRAME HYD MOUNTING (305337)

ITEM	PART NO.	DESCRIPTION	QTY
1	305794	WLDMT-SELECTOR MOUNT	1
2	1011584	WASHER-FLAT: SAE .50 ZP	2
3	1027461	NUT-TOPLOCK: .50 NC GR5 ZP	2
4	1011607	BOLT-HEX: .50 X 1.50 NC GR5 ZP	2
5	58470	VALVE-SELECTOR (6-WAY) PC WITH LINKAGE	1
6	68060	PLATE ZP	2
7	1011303	SCREW-MACH RND SLT: #10-24 X 1.25"	2
8	65712	NUT-NYLOCK: 10-24 GR2 SS	2
9	59390	BOLT-HEX: .38 X 2.25 NC GR5 ZP	2
10	1011828	WASHER-FLAT .38 ZP	2
11	1016999	NUT-TOPLOCK: .38 NC GR5 ZP	6
12	305659	WLDMT-VALVE BLOCK MOUNT	1
13	1014608	WASHER-FLAT: SAE .38 ZP	4
14	305663	BOLT-HEX: .38 X 10.00 NC GR5 ZP	2
15	34925	BOLT-HEX: .38 X 6.00 NC GR5 ZP	2
16	305666	FTG-PLUG: 8MB PLUG ALLEN HEX SOCKET (6409-8)	AR
17	307890	WLDMT-ROD HOLDER MNT	1
18	301025	GROMMET-RUBBER 1.50" ID	16
19	307564	HYDRAULIC BLOCK REAR DEF (AHC COMPATIBLE)	1
20	304189	ASSY-TRACTOR HYD COUPLERS (GOLD)	1

LIGHT KIT (305609)

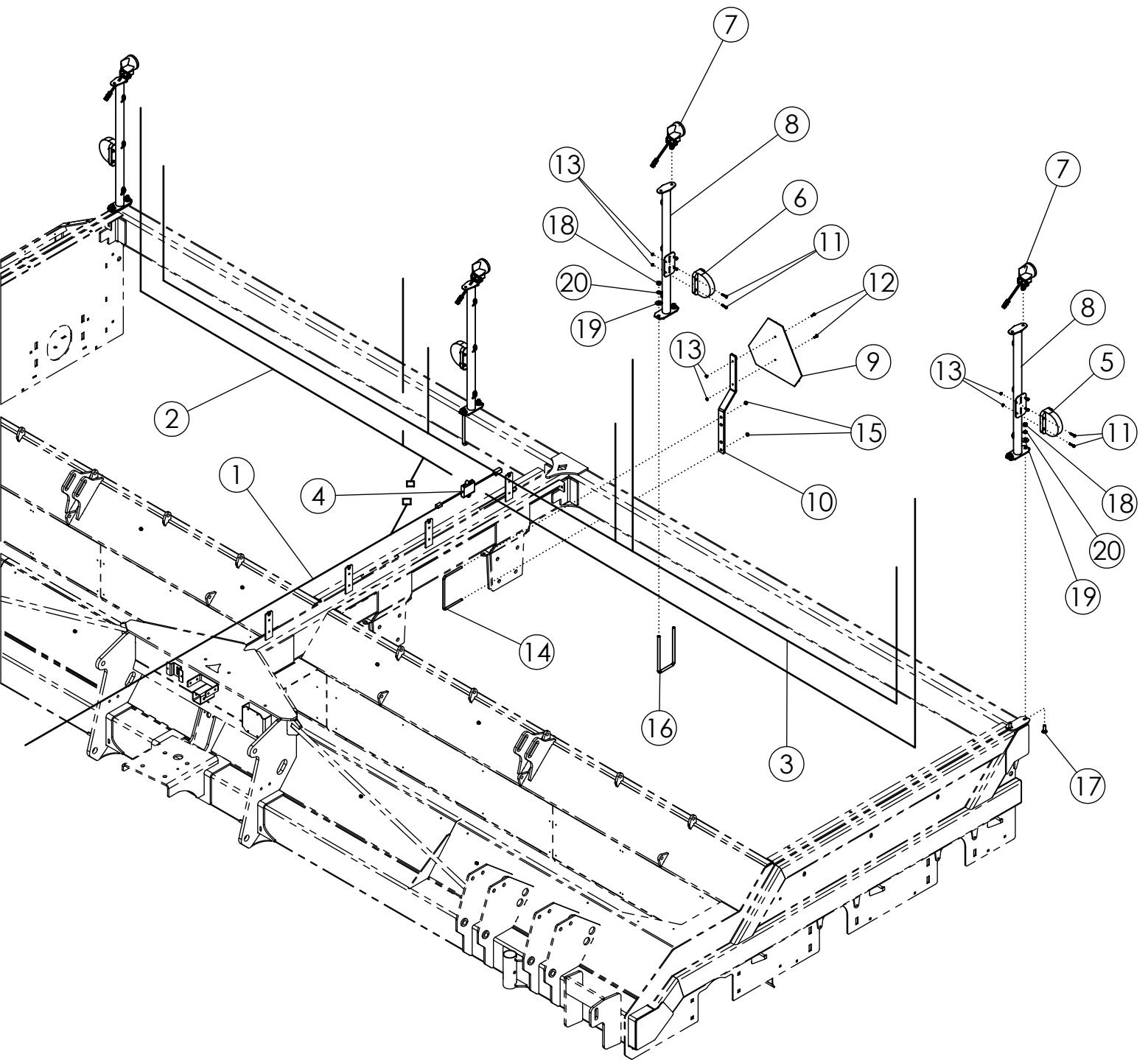

LIGHT KIT (305609)

ITEM	PART NO.	DESCRIPTION	QTY
1	305213	HARNESS-DEF MAIN 6R/8R/12R	1
2	305214	HARNESS-DEF WORK LIGHT 8R/12R	1
3	305215	HARNESS-DEF HAZARD 8R/12R	1
4	305216	HARNESS-FLASHER MODULE	1
5	305217	LIGHT-YELLOW LAMP SAE	2
6	305218	LIGHT-RED LAMP SAE	2
7	301294	LIGHT-GROTE T26 NEAR FLOOD	4
8	305219	WLDMT-LIGHT MOUNT	4
9	65329	SIGN-SMV ASAE S276.5	1
10	64246	MOUNT-SMV SIGN	1
11	1013940	BOLT-HEX: .25 X 1.25 NC GR5	16
12	1011595	BOLT-HEX: .25 X .75 NC GR5 ZP	2
13	1030946	NUT-TOPLOCK: .25 NC GR5 ZP	18
14	64244	U-BOLT: .375 X 5.125 X 8.063 X 5.125	1
15	1016999	NUT-TOPLOCK: .38 NC GR5 ZP	2
16	63458	U-BOLT: .50 X 9.25 X 4.00 X 9.25 ZP	2
17	1011660	BOLT-CRG: .50 X 1.50 NC GR5 ZP	4
18	1011577	NUT-HEX: .50 NC GR2 ZP	8
19	1014443	WASHER-FLAT: .50 ZP	8
20	1011581	WASHER-LOCK: .50 ZP	8
21	1013122	TIE-NYLON CABLE 50# X 15.50" (NOT SHOWN)	12

MANUAL STORAGE CASE DEF (64643)

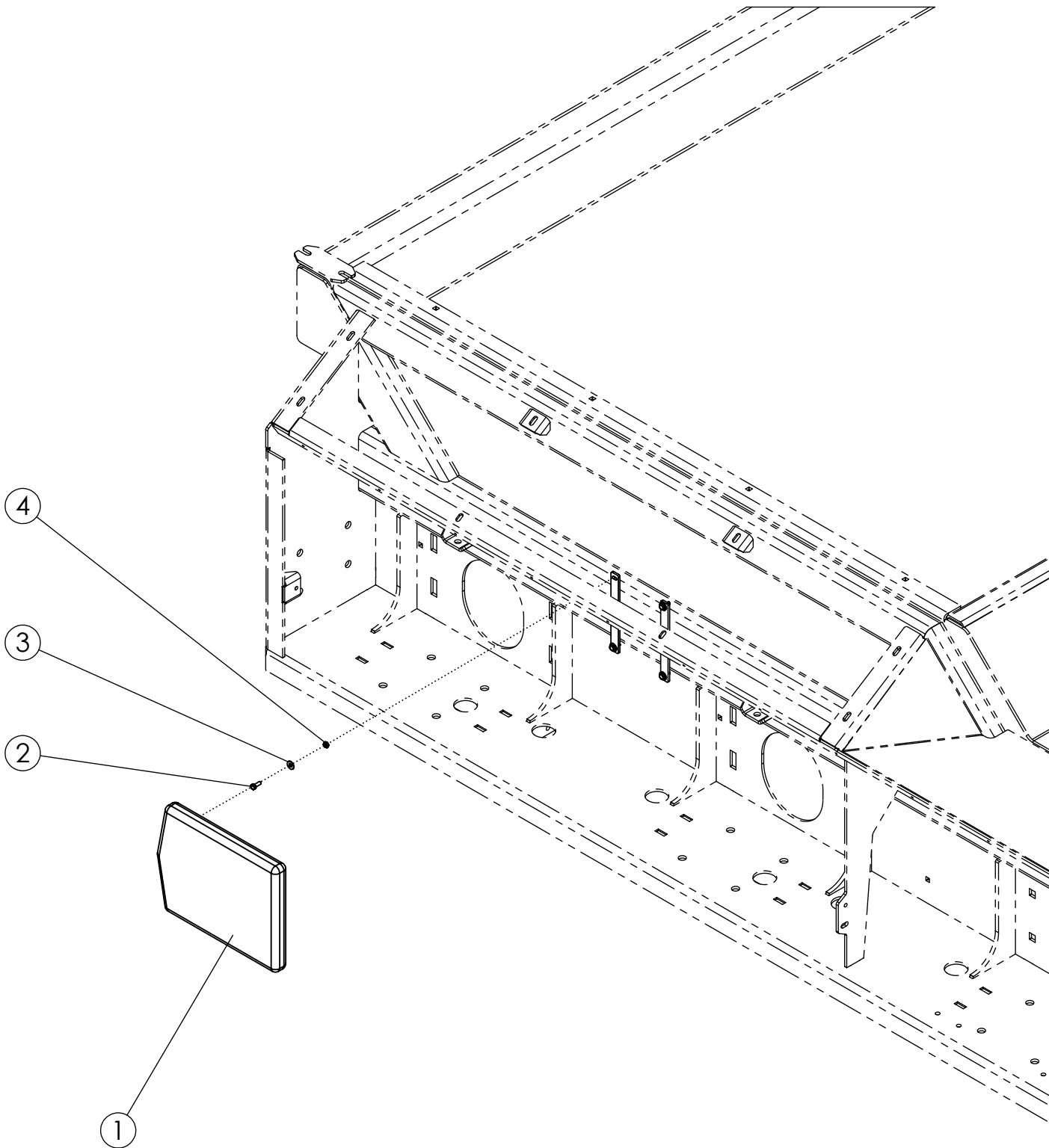

MANUAL STORAGE CASE DEF (64643)

ITEM	PART NO.	DESCRIPTION	QTY
1	64635	CASE-MANUAL STORAGE	1
2	1011595	BOLT-HEX: .25 X .75 NC GR5 ZP	4
3	1020416	WASHER-FLAT: .25 ZP	4
4	1030946	NUT-TOPLOCK: .25 NC GR5 ZP	4

WEIGHT KIT (305799)

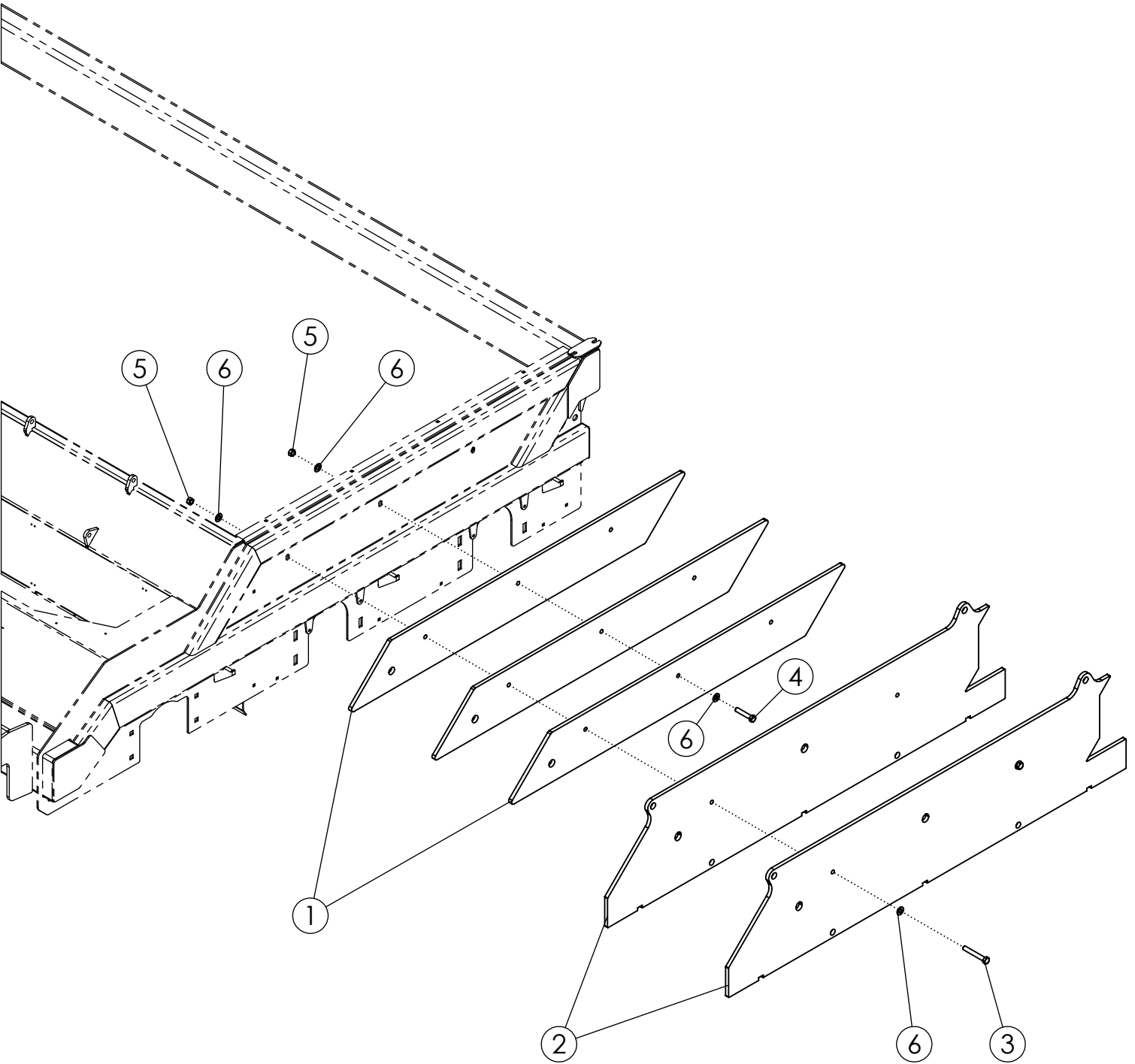

WEIGHT KIT (305799)

ITEM	PART NO.	DESCRIPTION	QTY
1	305789	PLATE-WEIGHT DEF	3
2	305798	PLATE-WEIGHT OUTER 12R DEF 50 SERIES	2
3	1013935	BOLT-HEX .63 X 4.50 NC GR5 ZP	2
4	65825	BOLT-HEX: .63 X 3.25 NC GR5 ZP	1
5	1016595	NUT-TOPLOCK: .63 NC GR5 ZP	3
6	1013004	WASHER-FLAT: SAE .63 ZP	6

AHC/FLOATING STRUT VALVE MOUNT (307016)

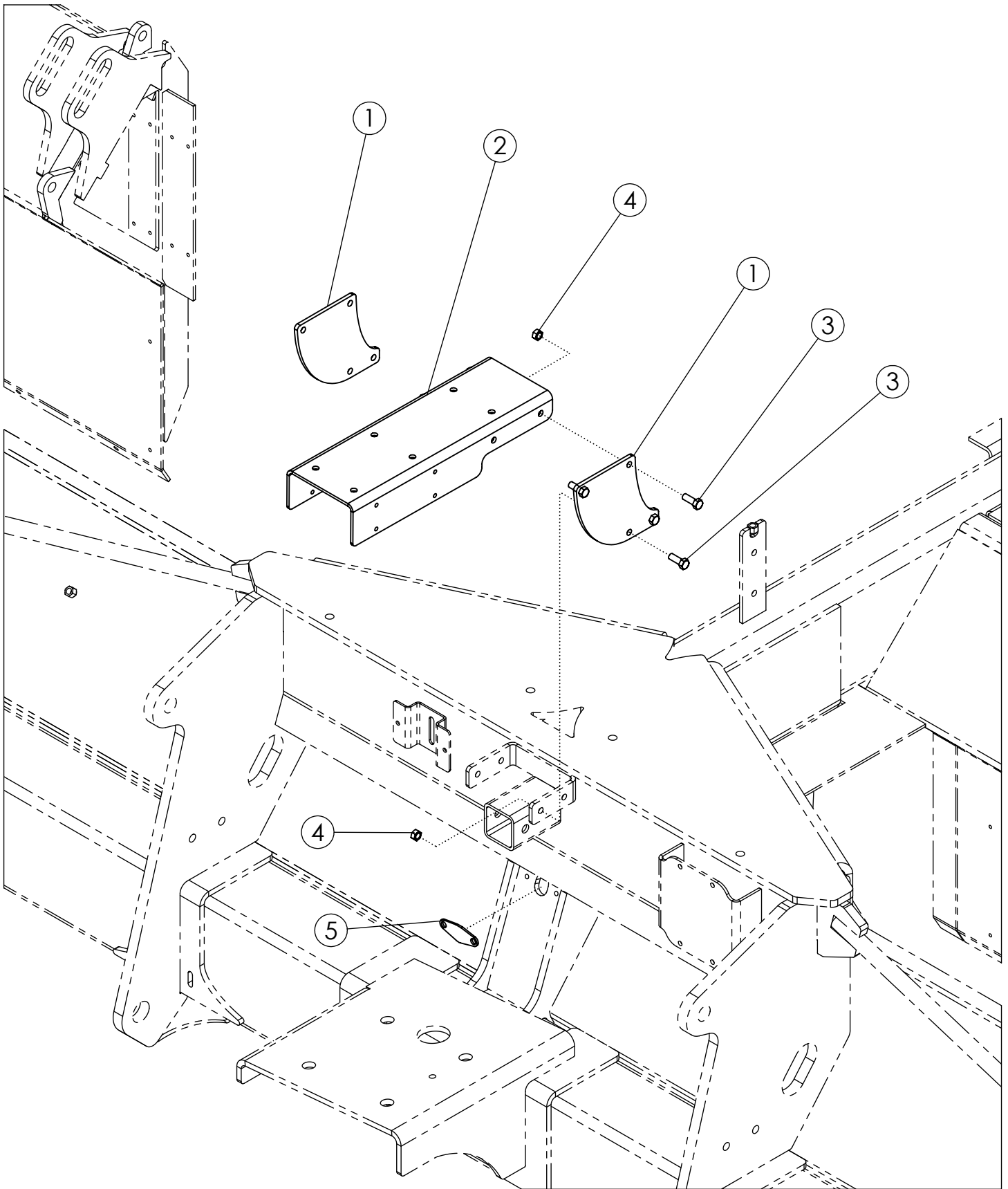

AHC/FLOATING STRUT VALVE MOUNT (307016)

ITEM	PART NO.	DESCRIPTION	QTY
1	306987	PLATE-AHC BASE EXTENDER	2
2	306988	PLATE-AHC BASE MOUNT	1
3	1011600	BOLT-HEX: .38 X 1.00 NC GR5 ZP	8
4	1016999	NUT-TOPLOCK: .38 NC GR5 ZP	8
5	307394	PLATE-HARNESS HOLE COVER	1

3750 DEF DECALS (305688)

FRONT VIEW

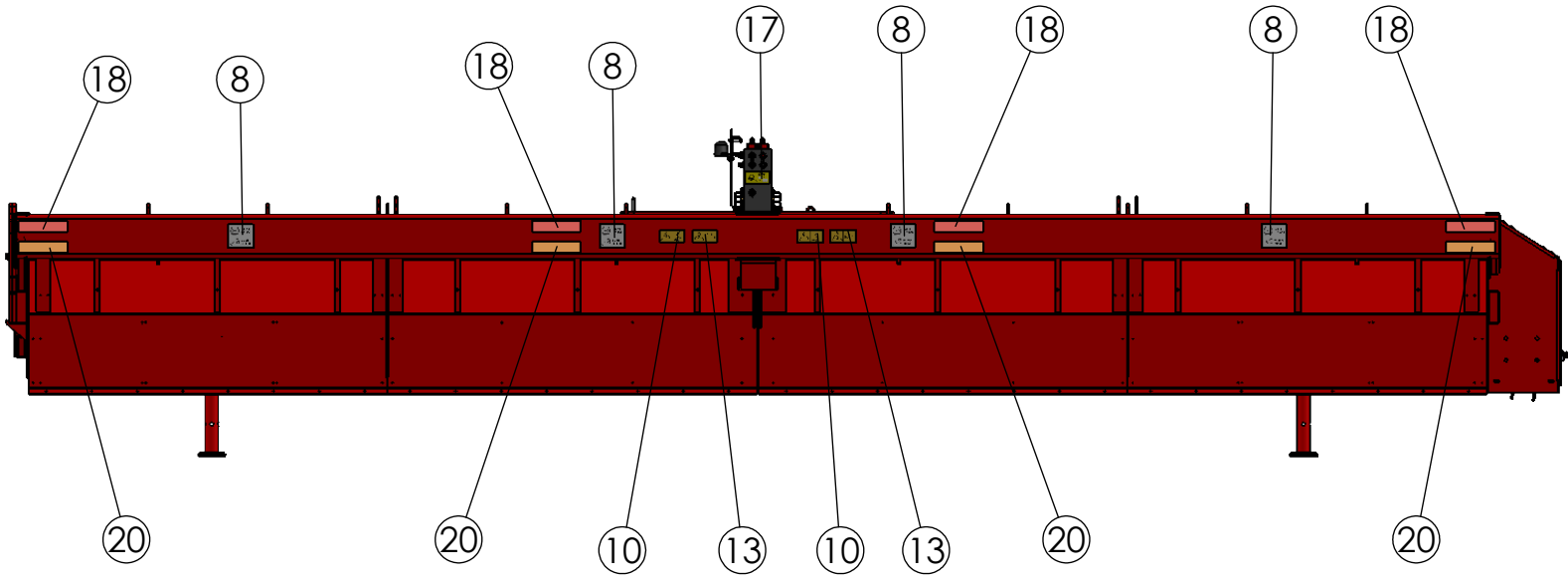
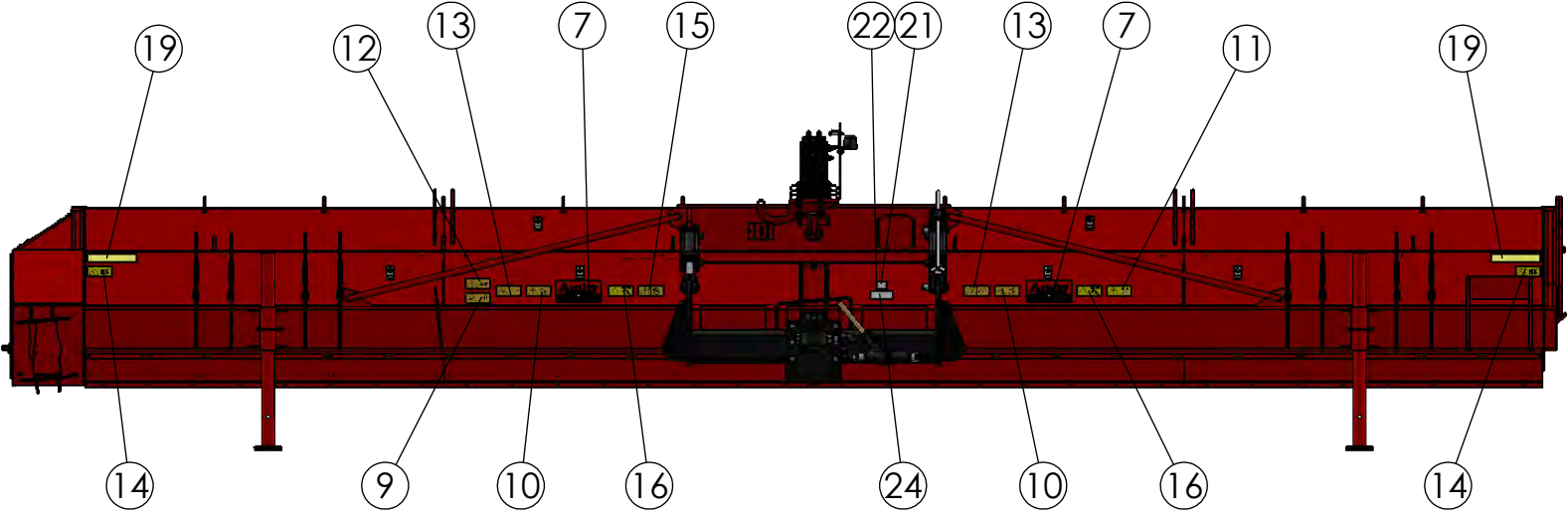

REAR VIEW

3750 DEF DECALS (305688)

ITEM	PART NO.	DESCRIPTION	QTY
1	305692	DECAL-3750 6X12	2
2	69405	DECAL-LH CURVE 7.25X22	1
3	69406	DECAL-LH STRIPE 4X63	1
4	69407	DECAL-RH CURVE 7.25X22	1
5	69408	DECAL-RH STRIPE 4X63	1
6	69399	DECAL-AMITY LOGO 12X24 (GRN GLB)	2
7	63465	DECAL-AMITY LOGO SMALL	2
8	303353	DECAL- TIRE PRESSURE DEF	4
9	9971013	DECAL-GUARD MISSING	2
10	303267	DECAL-DANGER FLAILS	4
11	997859	DECAL-ENGINE OFF	1
12	303268	DECAL-DANGER ROTATING	1
13	307165	DECAL-CAUTION DOORS	4
14	9971015	DECAL- FALL OFF HAZARD	2
15	303263	DECAL-DANGER MOVING PARTS	2
16	303265	DECAL-DANGER UNDER MACHINE	2
17	997867	DECAL- FLUID UNDER PRESSURE	1
18	65330	DECAL-RED RETROREFLECTIVE	4
19	65331	DECAL-YELLOW RETROREFLECTIVE	4
20	65332	DECAL-RED/ORANGE FLUORESCENT	4
21	1028371	TAG: SERIAL#/MODEL#/YEAR	1
22	59882	RIVET-POP: .13 X .31 ZP	2
23	307798	DECAL-HOSE COLOR CHART 50 SERIES	1
24	303769	DECAL-US PATENT QR CODE	1
25	303804	DECAL-PROUDLY MADE AT AMITY	1

3750 DEF DECALS (305688)

RH SIDE VIEW

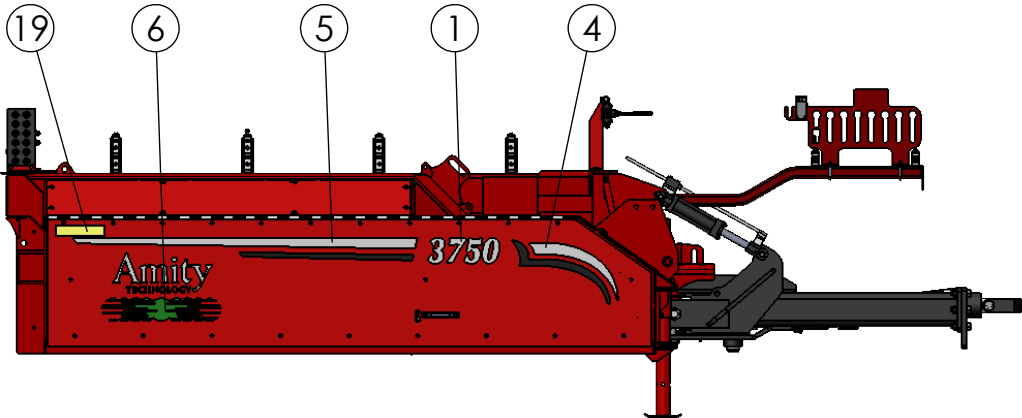

BEHIND SIDE DOOR

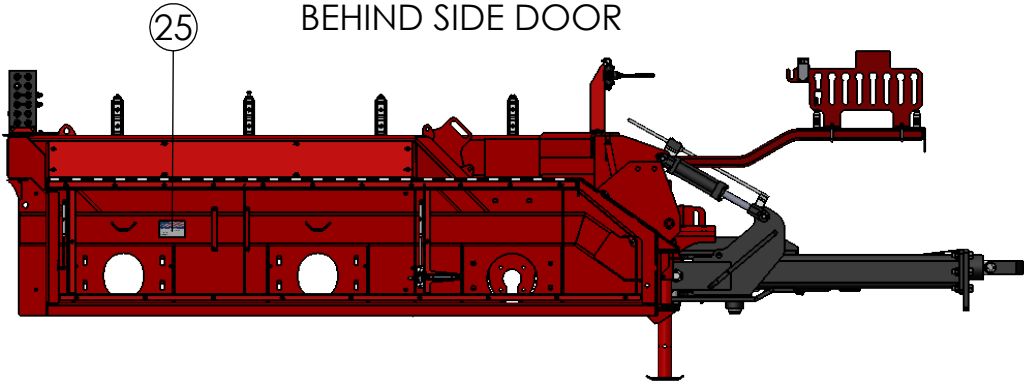

BACK OF SIDE DOOR

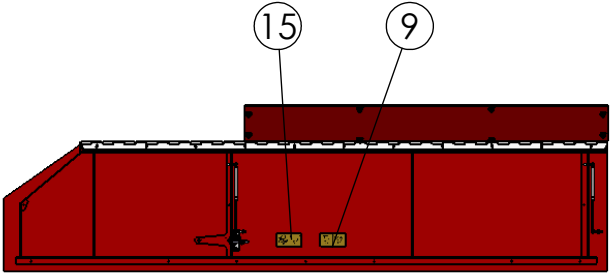

LH SIDE VIEW

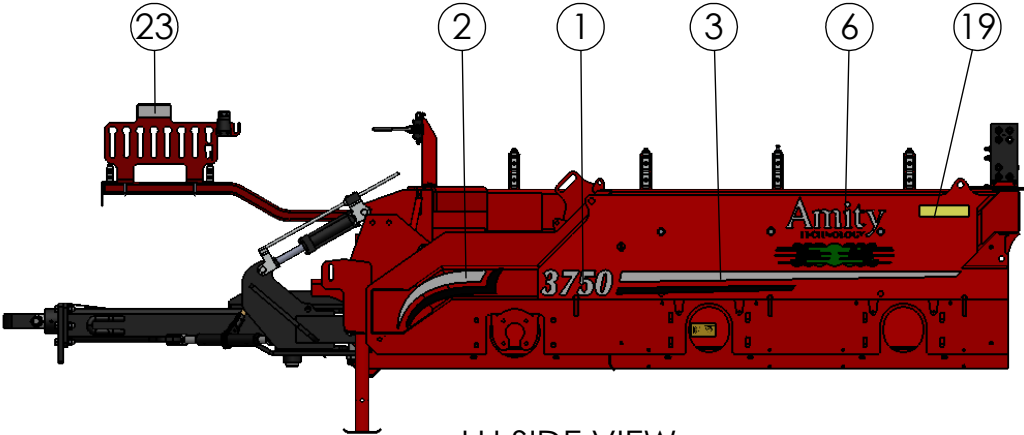

3750 DEF DECALS (305688)

ITEM	PART NO.	DESCRIPTION	QTY
1	305692	DECAL-3750 6X12	2
2	69405	DECAL-LH CURVE 7.25X22	1
3	69406	DECAL-LH STRIPE 4X63	1
4	69407	DECAL-RH CURVE 7.25X22	1
5	69408	DECAL-RH STRIPE 4X63	1
6	69399	DECAL-AMITY LOGO 12X24 (GRN GLB)	2
7	63465	DECAL-AMITY LOGO SMALL	2
8	303353	DECAL- TIRE PRESSURE DEF	4
9	9971013	DECAL-GUARD MISSING	2
10	303267	DECAL-DANGER FLAILS	4
11	997859	DECAL-ENGINE OFF	1
12	303268	DECAL-DANGER ROTATING	1
13	307165	DECAL-CAUTION DOORS	4
14	9971015	DECAL- FALL OFF HAZARD	2
15	303263	DECAL-DANGER MOVING PARTS	2
16	303265	DECAL-DANGER UNDER MACHINE	2
17	997867	DECAL- FLUID UNDER PRESSURE	1
18	65330	DECAL-RED RETROREFLECTIVE	4
19	65331	DECAL-YELLOW RETROREFLECTIVE	4
20	65332	DECAL-RED/ORANGE FLUORESCENT	4
21	1028371	TAG: SERIAL#/MODEL#/YEAR	1
22	59882	RIVET-POP: .13 X .31 ZP	2
23	307798	DECAL-HOSE COLOR CHART 50 SERIES	1
24	303769	DECAL-US PATENT QR CODE	1
25	303804	DECAL-PROUDLY MADE AT AMITY	1

FRONT DRUM 8R30 (305545)

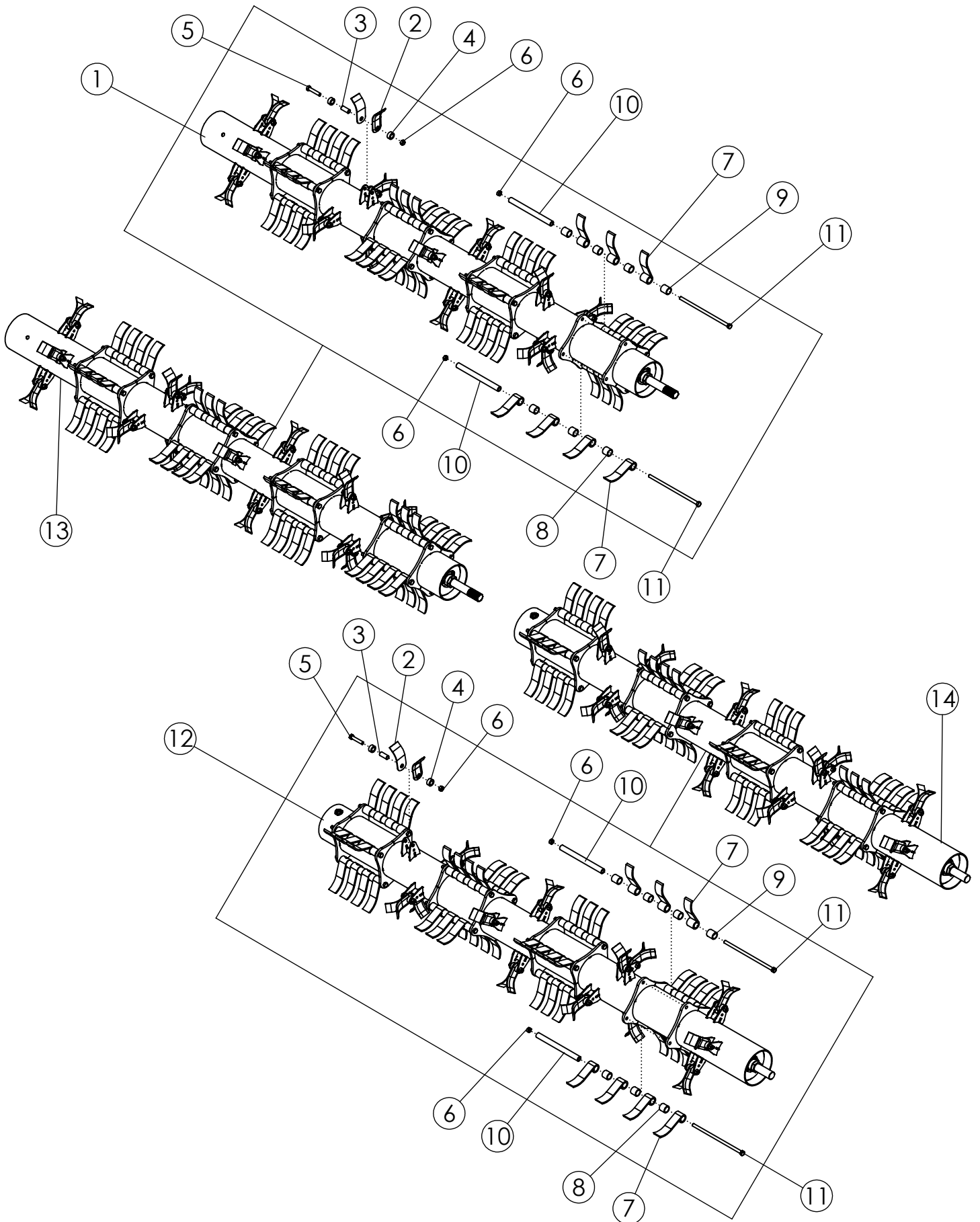

FRONT DRUM 8R30 (305545)

ITEM	PART NO.	DESCRIPTION	QTY
1	307270	WLDMT-STEEL FLAIL TUBE RH 830 HS	1
2	307236	FLAIL-STEEL 5.31" LONG	64
3	68427	BUSHING-L KNIFE	32
4	68426	SPACER-POLYURETHANE L KNIFE	64
5	65825	BOLT-HEX: .63 X 3.25 NC GR5 ZP	32
6	1016595	NUT-TOPLOCK: .63 NC GR5 ZP	64
7	307387	FLAIL-CUP 7.0" 1.25" EYE	112
8	307390	SPACER 1.45" LARGE- 1.25" EYE	80
9	307391	SPACER 1.70" LARGE- 1.25" EYE	32
10	307388	BUSHING-FLAIL 12.688" 1.13" OD HT	32
11	306766	BOLT-HEX: .63 X 14.875 NC GR8 ZP	32
12	307277	WLDMT-STEEL FLAIL TUBE-LH 830 HS	1
13	307268	ASSY-STL DRUM RH 830 HS BALANCED	1
14	307275	ASSY-STL DRUM LH 830 HS BALANCED	1

FALSE WALL 8R30 (305780)

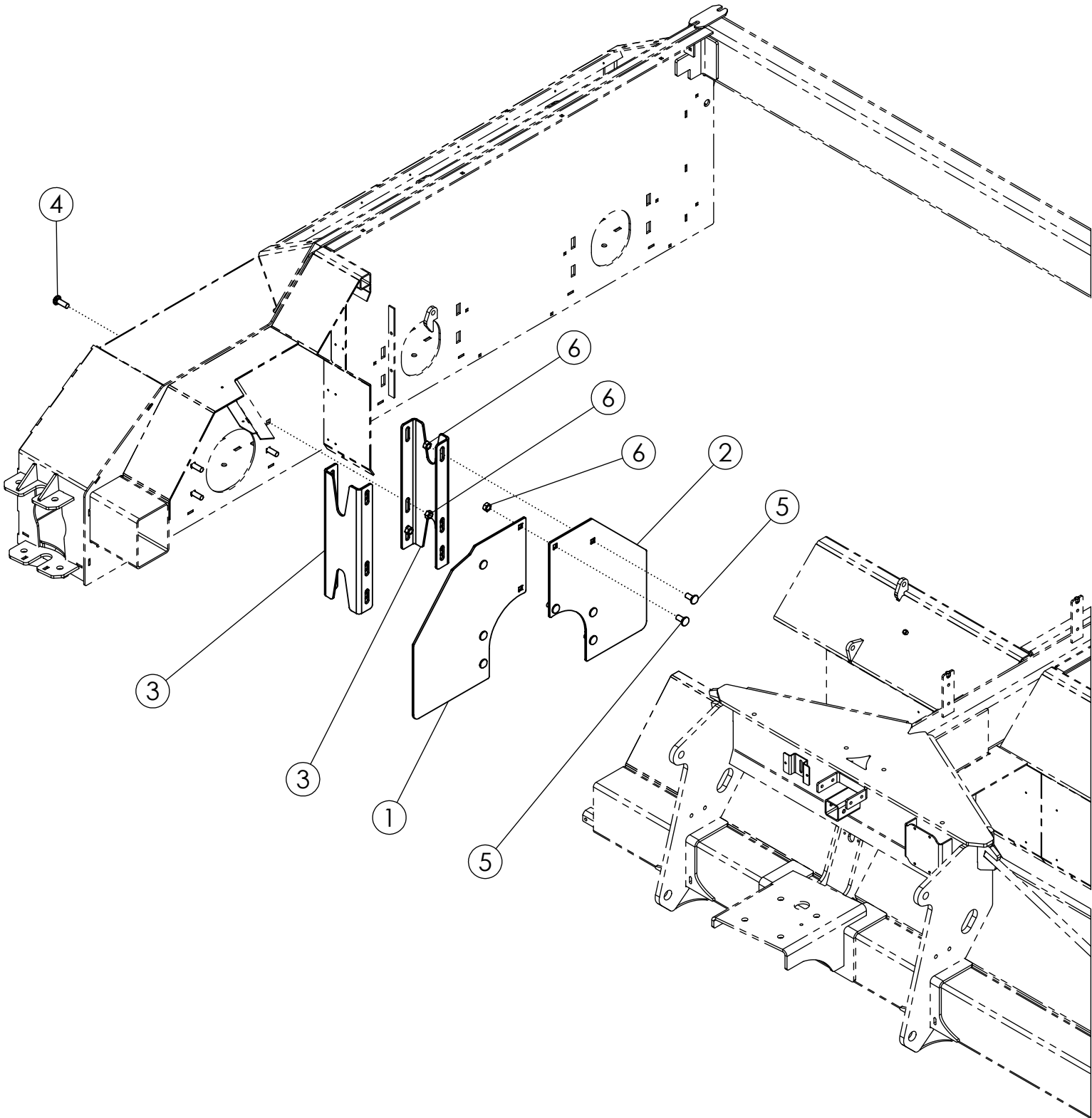

FALSE WALL 8R30 (305780)

ITEM	PART NO.	DESCRIPTION	QTY
1	307757	PLATE-FRONT HALF FALSE WALL	2
2	307758	PLATE-REAR HALF FALSE WALL	2
3	305897	PLATE-FALSE WALL SUPPORT 3750	4
4	58635	BOLT-CRG: .63 X 2.00 NC GR5 ZP	8
5	72063	BOLT-CRG: .63 X 1.50 NC GR5 ZP	16
6	1016595	NUT-TOPLOCK: .63 NC GR5 ZP	24

FRONT DRUM 12R22 (305521)

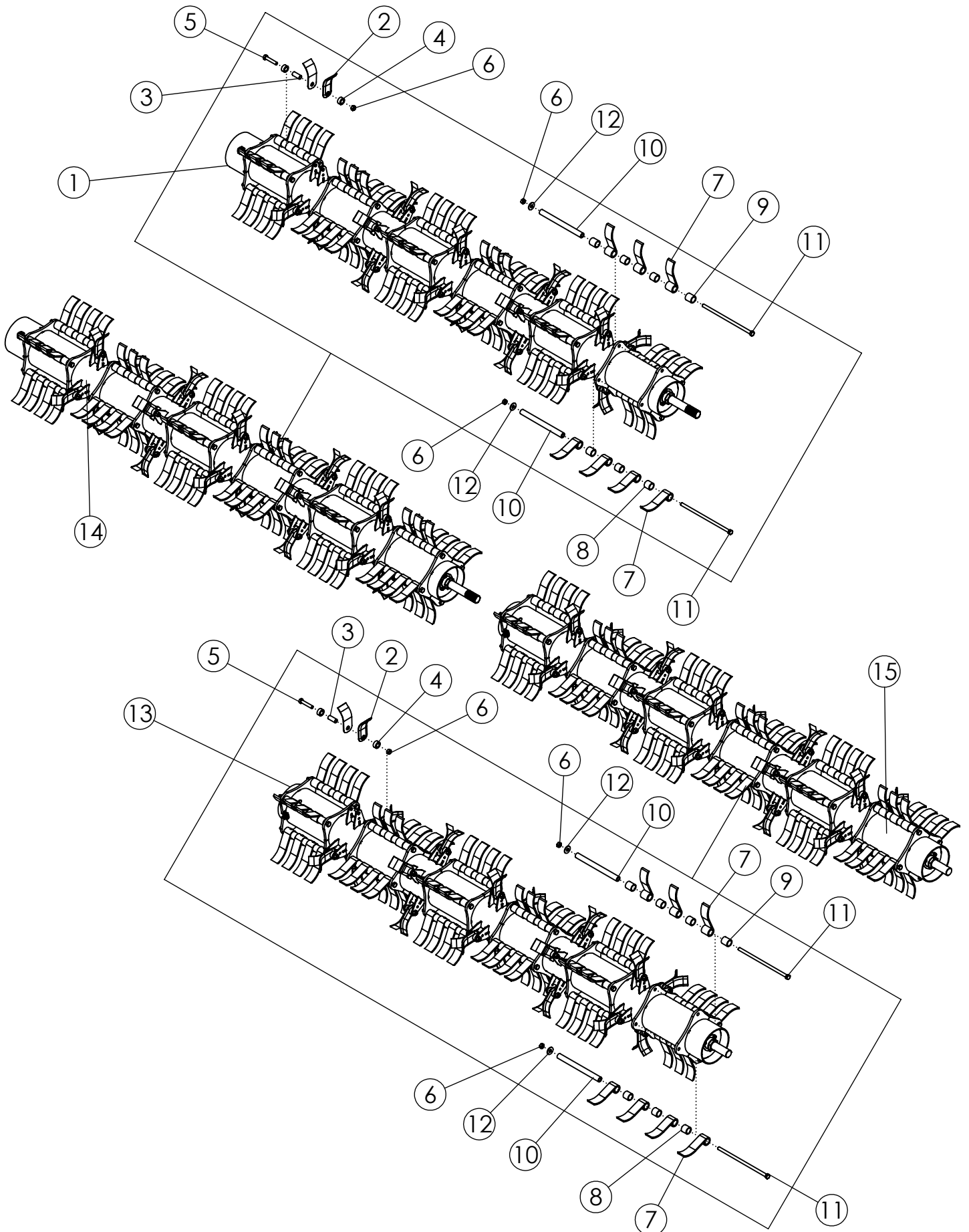

FRONT DRUM 12R22 (305521)

ITEM	PART NO.	DESCRIPTION	QTY
1	307227	WLDMT-STEEL FLAIL TUBE RH 1222 HS	1
2	307236	FLAIL-STEEL 5.31" LONG	80
3	68427	BUSHING-L KNIFE	40
4	68426	SPACER-POLYURETHANE L KNIFE	80
5	65825	BOLT-HEX: .63 X 3.25 NC GR5 ZP	40
6	1016595	NUT-TOPLOCK: .63 NC GR5 ZP	88
7	307387	FLAIL-CUP 7.0" 1.25" EYE	168
8	307390	SPACER 1.45" LARGE- 1.25" EYE	120
9	307391	SPACER 1.70" LARGE- 1.25" EYE	48
10	307388	BUSHING-FLAIL 12.688" 1.13" OD HT	48
11	306766	BOLT-HEX: .63 X 14.875 NC GR8 ZP	48
12	1013024	WASHER-FLAT: .63 ZP	48
13	307243	WLDMT-STEEL FLAIL TUBE-LH 1222 HS	1
14	307225	ASSY-STL DRUM RH 1222 HS BALANCED	1
15	307241	ASSY-STL DRUM LH 1222 HS BALANCED	1

STUDED FLAIL #2 10 ROD 22" (305776)

ITEM	PART NO.	DESCRIPTION	QTY
1	305523	WLDMT-FLAIL RING 10 ROD HINGE ZP	2
2	305522	WLDMT-FLAIL RING 10 ROD ZP	2
3	305499	WLDMT-10 FLAIL ROD	10
4	1011601	BOLT-HEX: .38 X 1.25 NC GR5 ZP	10
5	1016999	NUT-TOPLOCK: .38 NC GR5 ZP	10
6	1011607	BOLT-HEX: .50 X 1.50 NC GR5 ZP	4
7	1027461	NUT-TOPLOCK: .50 NC GR5 ZP	4
8	52356	FLAIL-STUDED 1 X 12	45
9	51547	SPACER-5/16"	10
10	51548	SPACER 1-7/16"	10

TAPERED FLAIL #2 10 ROD 22" (305696)

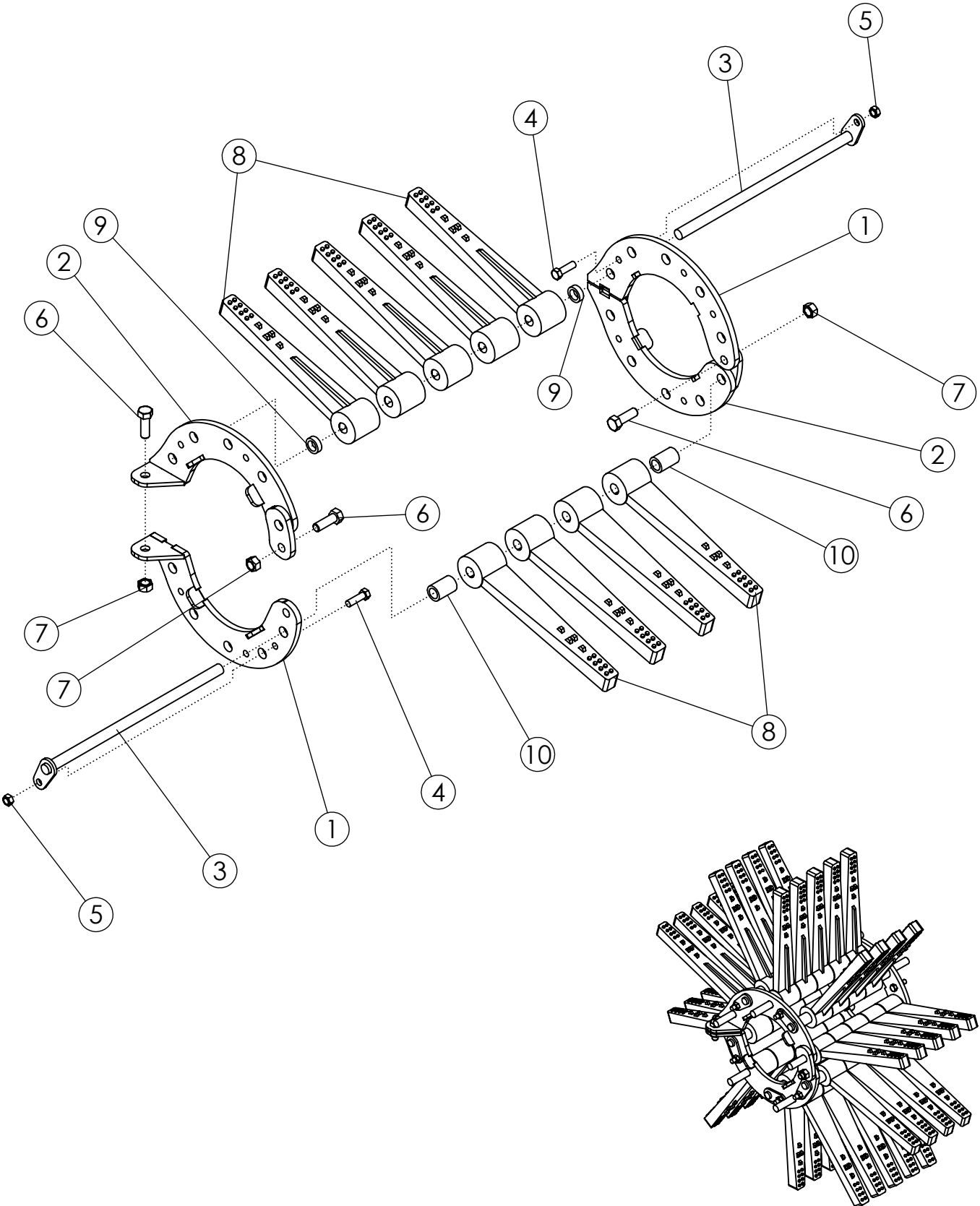

TAPERED FLAIL #2 10 ROD 22" (305696)

ITEM	PART NO.	DESCRIPTION	QTY
1	305522	WLDMT-FLAIL RING 10 ROD ZP	2
2	305523	WLDMT-FLAIL RING 10 ROD HINGE ZP	2
3	305499	WLDMT-10 FLAIL ROD	10
4	1011601	BOLT-HEX: .38 X 1.25 NC GR5 ZP	10
5	1016999	NUT-TOPLOCK: .38 NC GR5 ZP	10
6	1011607	BOLT-HEX: .50 X 1.50 NC GR5 ZP	4
7	1027461	NUT-TOPLOCK: .50 NC GR5 ZP	4
8	307259	FLAIL-RUBBER 1 X 12 TAPERED	45
9	51547	SPACER-5/16"	10
10	51548	SPACER 1-7/16"	10

SWEEP/SPLIT FLAIL #3 22" (52125)

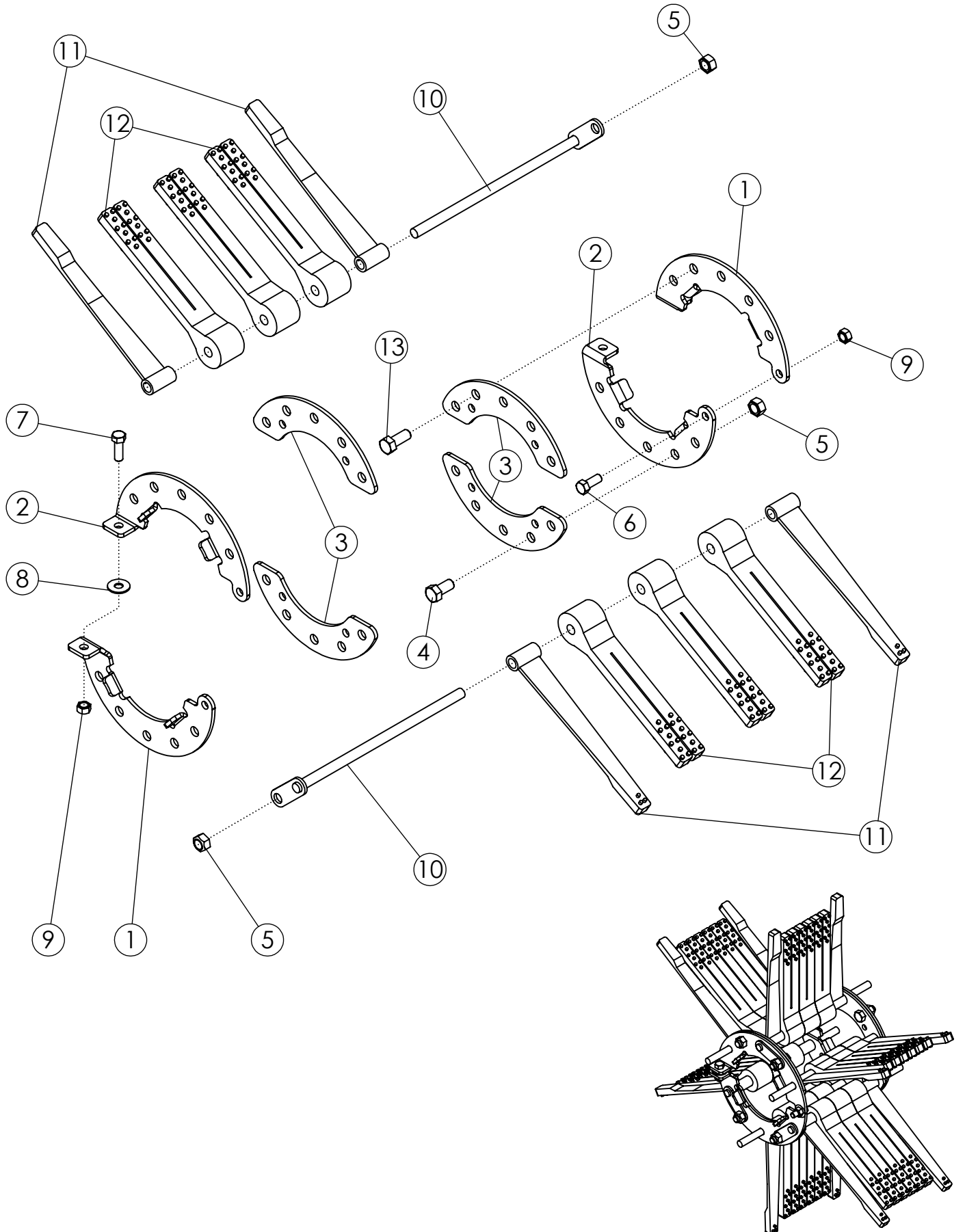

SWEEP/SPLIT FLAIL #3 22" (52125)

ITEM	PART NO.	DESCRIPTION	QTY
1	52062	FLAIL RING LH - ZP	2
2	52061	FLAIL RING RH - ZP	2
3	58084	PLATE-REINFORCEMENT ZP	4
4	1032509	BOLT-HEX: .63 X 1.25 NC GR5 ZP	2
5	1016595	NUT-TOPLOCK: .63 NC GR5 ZP	8
6	1011606	BOLT-HEX: .50 X 1.25 NC GR5 ZP	2
7	1011607	BOLT-HEX: .50 X 1.50 NC GR5 ZP	2
8	1014443	WASHER-FLAT: .50 ZP	2
9	1027461	NUT-TOPLOCK: .50 NC GR5 ZP	4
10	305557	WLDMT-6 FLAIL ROD 13.875" ZP	6
11	52355	FLAIL-SWEEP 1 X 13.25	12
12	58255	FLAIL-SPLIT TAPER 2 X 12	18
13	1014349	BOLT-HEX: .63 X 1.50 NC GR5 ZP	6

SWEEP/STUDED FLAIL #3 22" (64319)

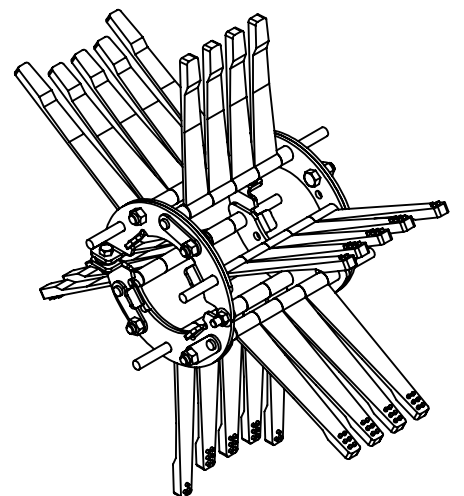
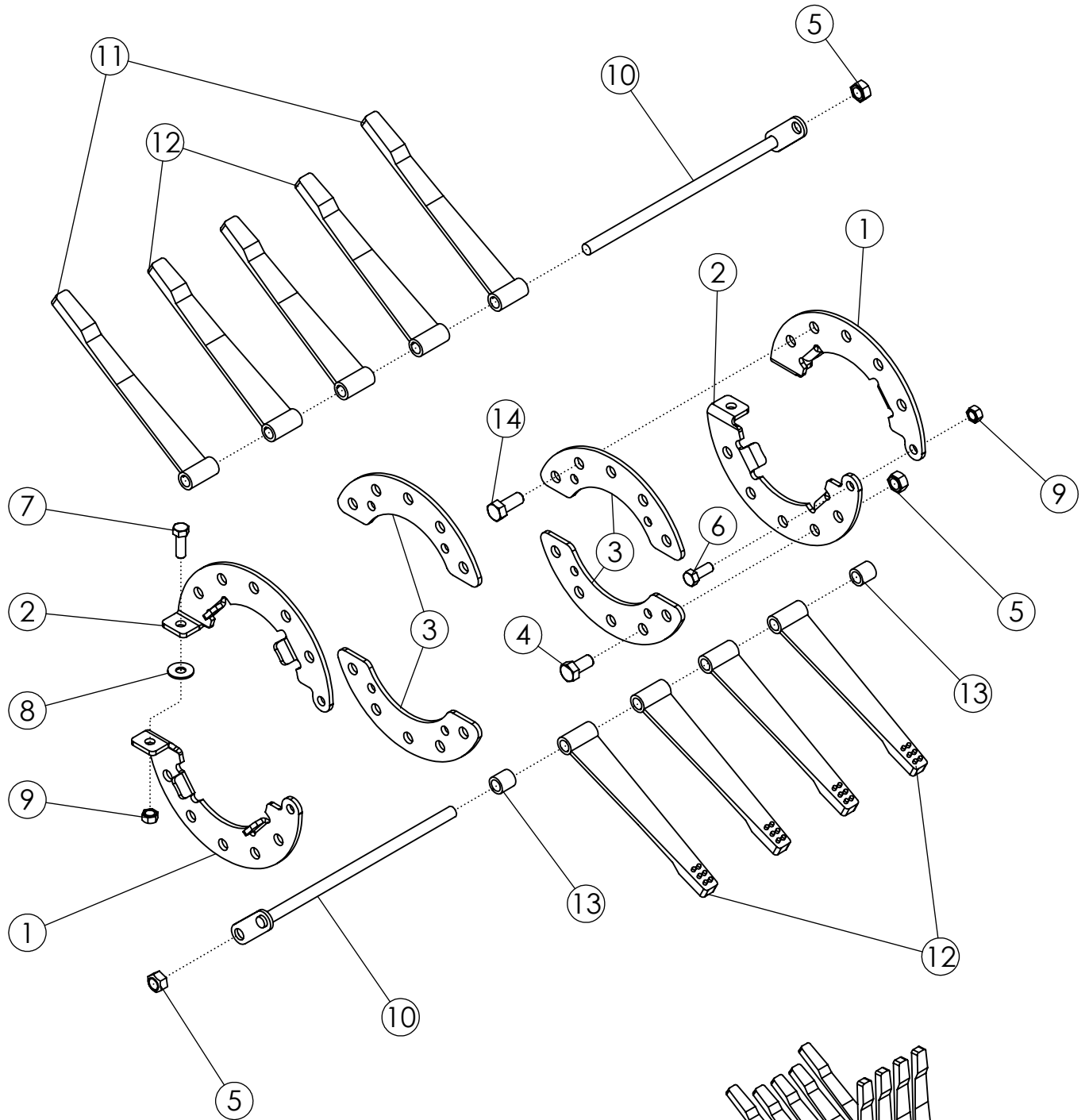

SWEEP/STUDED FLAIL #3 22" (64319)

ITEM	PART NO.	DESCRIPTION	QTY
1	52062	FLAIL RING LH - ZP	2
2	52061	FLAIL RING RH - ZP	2
3	58084	PLATE-REINFORCEMENT ZP	4
4	1032509	BOLT-HEX: .63 X 1.25 NC GR5 ZP	2
5	1016595	NUT-TOPLOCK: .63 NC GR5 ZP	8
6	1011606	BOLT-HEX: .50 X 1.25 NC GR5 ZP	2
7	1011607	BOLT-HEX: .50 X 1.50 NC GR5 ZP	2
8	1014443	WASHER-FLAT: .50 ZP	2
9	1027461	NUT-TOPLOCK: .50 NC GR5 ZP	4
10	305557	WLDMT-6 FLAIL ROD 13.875" ZP	6
11	52355	FLAIL-SWEEP 1 X 13.25	6
12	52356	FLAIL-STUDED 1 X 12	21
13	51549	SPACER-1"	6
14	1014349	BOLT-HEX: .63 X 1.50 NC GR5 ZP	6

SWEEP/TAPERED FLAIL #3 22" (68920)

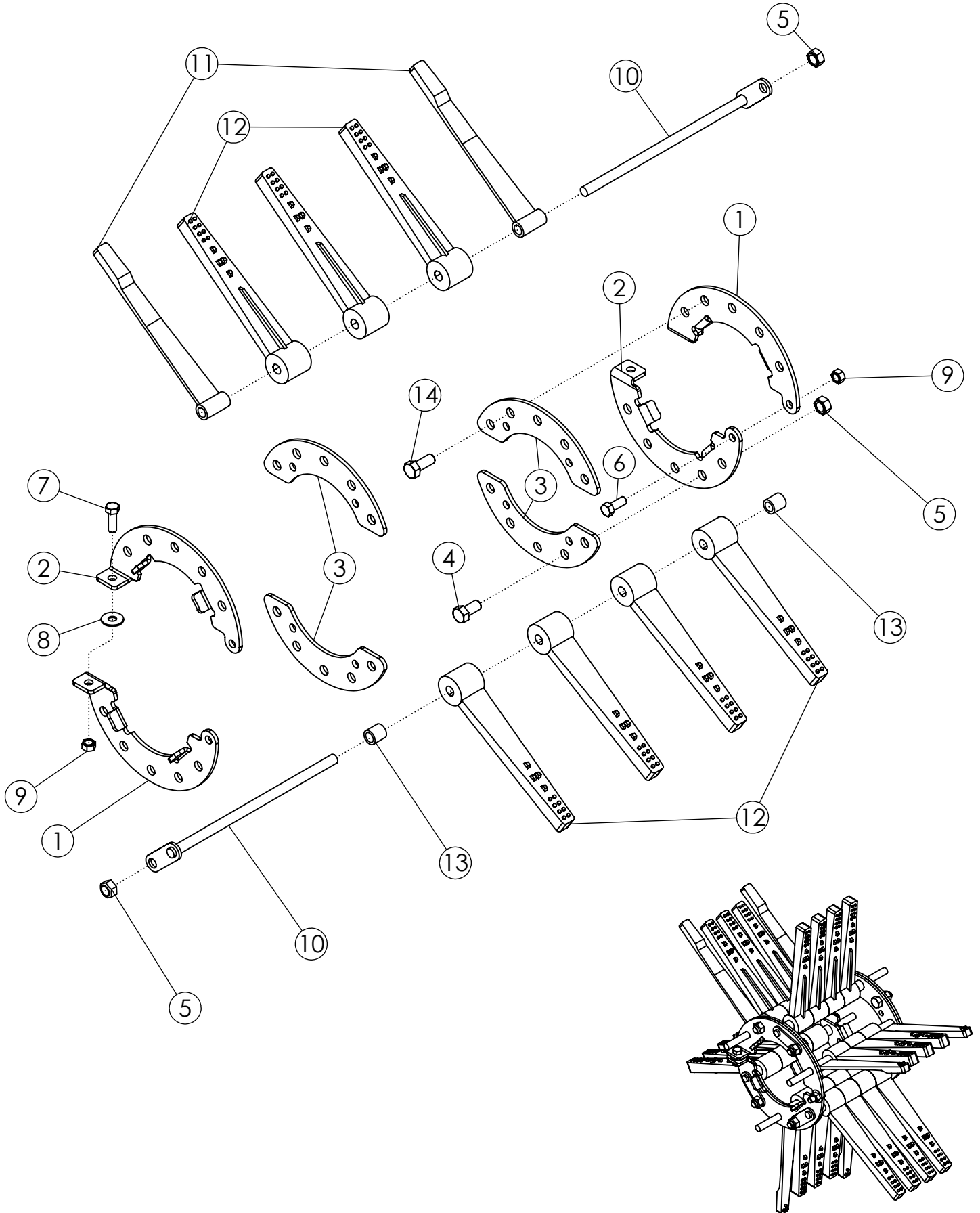

SWEEP/TAPERED FLAIL #3 22" (68920)

ITEM	PART NO.	DESCRIPTION	QTY
1	52062	FLAIL RING LH - ZP	2
2	52061	FLAIL RING RH - ZP	2
3	58084	PLATE-REINFORCEMENT ZP	4
4	1032509	BOLT-HEX: .63 X 1.25 NC GR5 ZP	2
5	1016595	NUT-TOPLOCK: .63 NC GR5 ZP	8
6	1011606	BOLT-HEX: .50 X 1.25 NC GR5 ZP	2
7	1011607	BOLT-HEX: .50 X 1.50 NC GR5 ZP	2
8	1014443	WASHER-FLAT: .50 ZP	2
9	1027461	NUT-TOPLOCK: .50 NC GR5 ZP	4
10	305557	WLDMT-6 FLAIL ROD 13.875" ZP	6
11	52355	FLAIL-SWEEP 1 X 13.25	6
12	307259	FLAIL-RUBBER 1 X 12 TAPERED	21
13	51549	SPACER-1"	6
14	1014349	BOLT-HEX: .63 X 1.50 NC GR5 ZP	6

SWEEP/TAPERED/2" FLAIL #3 22" (69413)

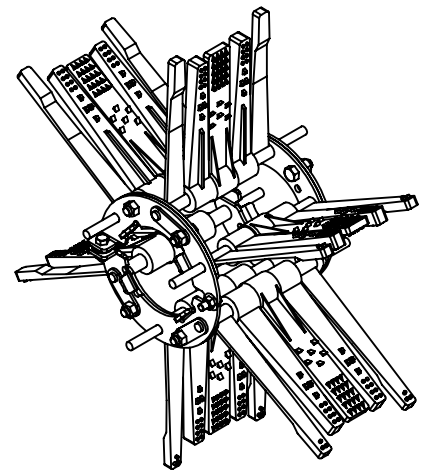
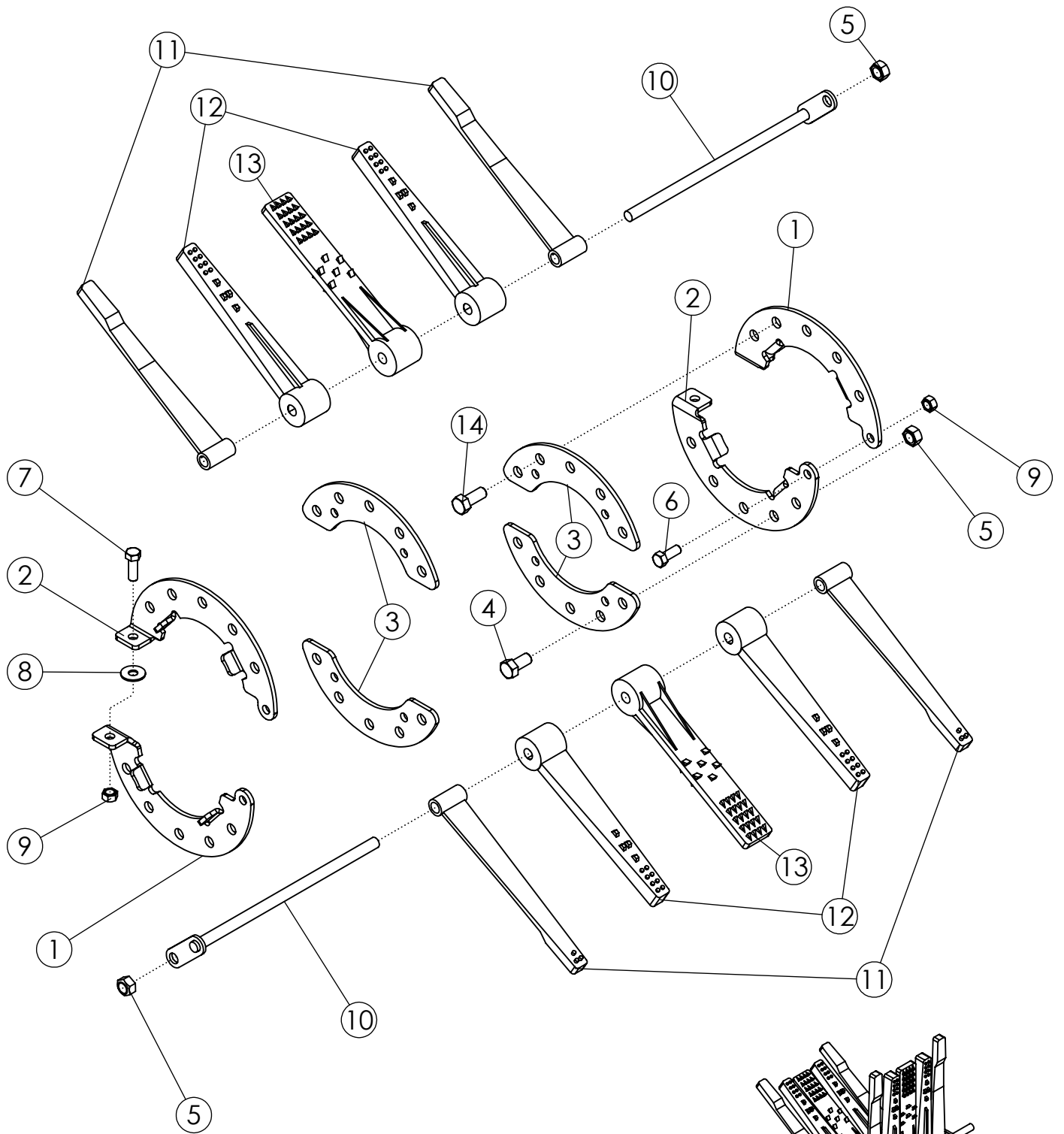

SWEEP/TAPERED/2" FLAIL #3 22" (69413)

ITEM	PART NO.	DESCRIPTION	QTY
1	52062	FLAIL RING LH - ZP	2
2	52061	FLAIL RING RH - ZP	2
3	58084	PLATE-REINFORCEMENT ZP	4
4	1032509	BOLT-HEX: .63 X 1.25 NC GR5 ZP	2
5	1016595	NUT-TOPLOCK: .63 NC GR5 ZP	8
6	1011606	BOLT-HEX: .50 X 1.25 NC GR5 ZP	2
7	1011607	BOLT-HEX: .50 X 1.50 NC GR5 ZP	2
8	1014443	WASHER-FLAT: .50 ZP	2
9	1027461	NUT-TOPLOCK: .50 NC GR5 ZP	4
10	305557	WLDMT-6 FLAIL ROD 13.875" ZP	6
11	52355	FLAIL-SWEEP 1 X 13.25	12
12	307259	FLAIL-RUBBER 1 X 12 TAPERED	12
13	307261	FLAIL-RUBBER 2 X 12	6
14	1014349	BOLT-HEX: .63 X 1.50 NC GR5 ZP	6

LONG SWEEP/TAPERED/2" FLAIL #3 22" (69555)

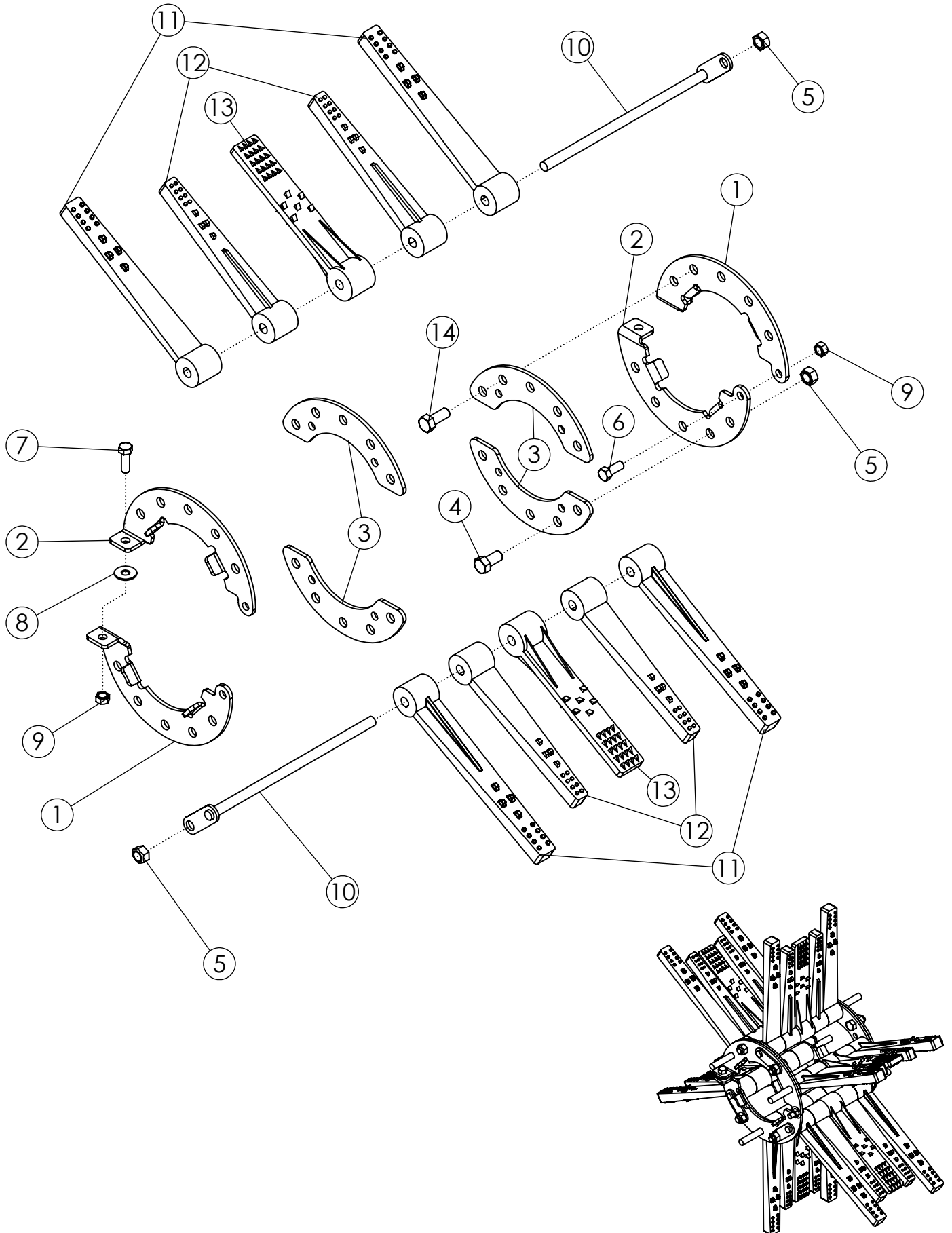

LONG SWEEP/TAPERED/2" FLAIL #3 22" (69555)

ITEM	PART NO.	DESCRIPTION	QTY
1	52062	FLAIL RING LH - ZP	2
2	52061	FLAIL RING RH - ZP	2
3	58084	PLATE-REINFORCEMENT ZP	4
4	1032509	BOLT-HEX: .63 X 1.25 NC GR5 ZP	2
5	1016595	NUT-TOPLOCK: .63 NC GR5 ZP	8
6	1011606	BOLT-HEX: .50 X 1.25 NC GR5 ZP	2
7	1011607	BOLT-HEX: .50 X 1.50 NC GR5 ZP	2
8	1014443	WASHER-FLAT: .50 ZP	2
9	1027461	NUT-TOPLOCK: .50 NC GR5 ZP	4
10	305557	WLDMT-6 FLAIL ROD 13.875" ZP	6
11	307260	FLAIL-RUBBER 1.5 X 14" SWEEP	12
12	307259	FLAIL-RUBBER 1 X 12 TAPERED	12
13	307261	FLAIL-RUBBER 2 X 12	6
14	1014349	BOLT-HEX: .63 X 1.50 NC GR5 ZP	6

SWEEP/SPLIT FLAIL #3 30" (52128)

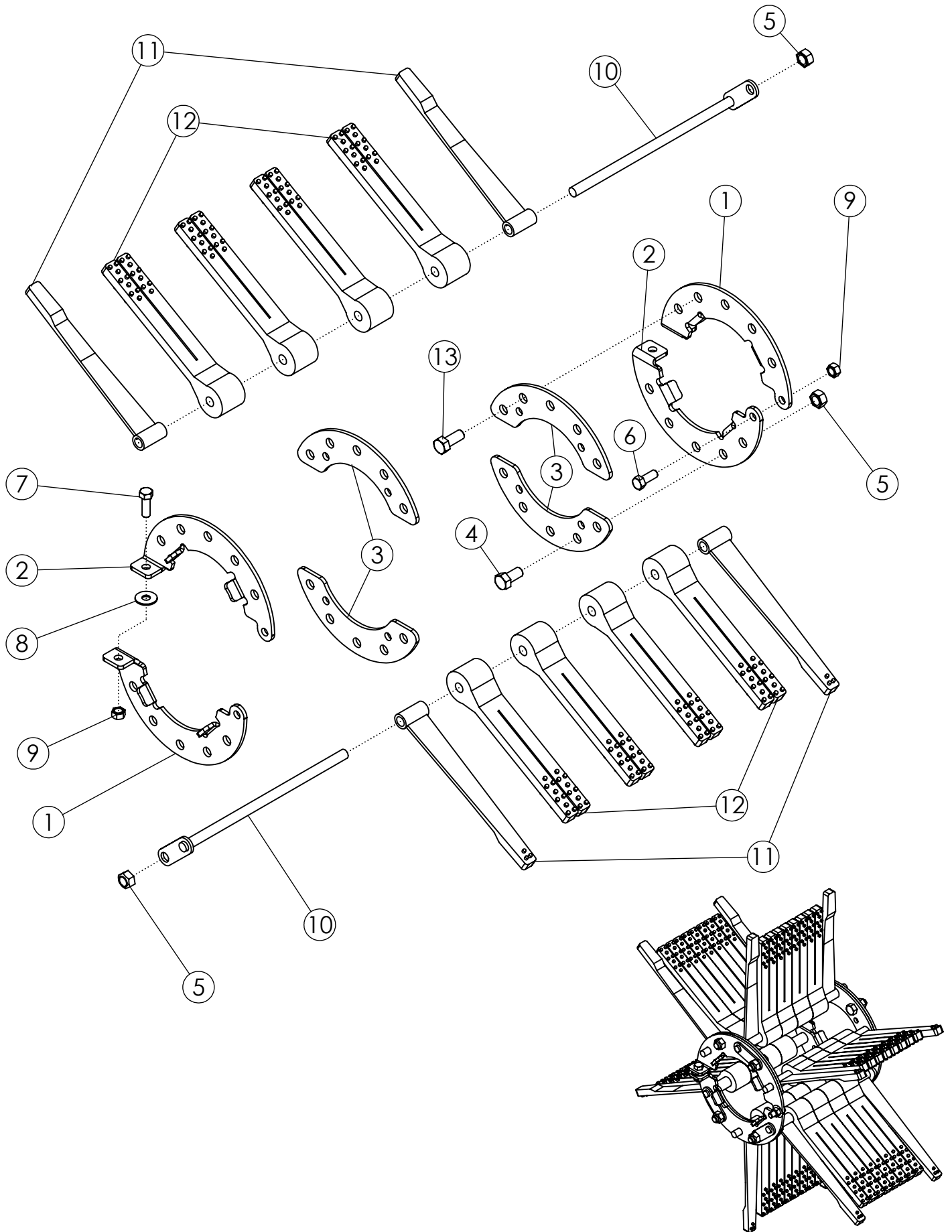

SWEEP/SPLIT FLAIL #3 30" (52128)

ITEM	PART NO.	DESCRIPTION	QTY
1	52062	FLAIL RING LH - ZP	2
2	52061	FLAIL RING RH - ZP	2
3	58084	PLATE-REINFORCEMENT ZP	4
4	1032509	BOLT-HEX: .63 X 1.25 NC GR5 ZP	2
5	1016595	NUT-TOPLOCK: .63 NC GR5 ZP	8
6	1011606	BOLT-HEX: .50 X 1.25 NC GR5 ZP	2
7	1011607	BOLT-HEX: .50 X 1.50 NC GR5 ZP	2
8	1014443	WASHER-FLAT: .50 ZP	2
9	1027461	NUT-TOPLOCK: .50 NC GR5 ZP	4
10	305557	WLDMT-6 FLAIL ROD 13.875" ZP	6
11	52355	FLAIL-SWEEP 1 X 13.25	12
12	58255	FLAIL-SPLIT TAPER 2 X 12	24
13	1014349	BOLT-HEX: .63 X 1.50 NC GR5 ZP	6

SWEEP/STUDED FLAIL #3 30" (69853)

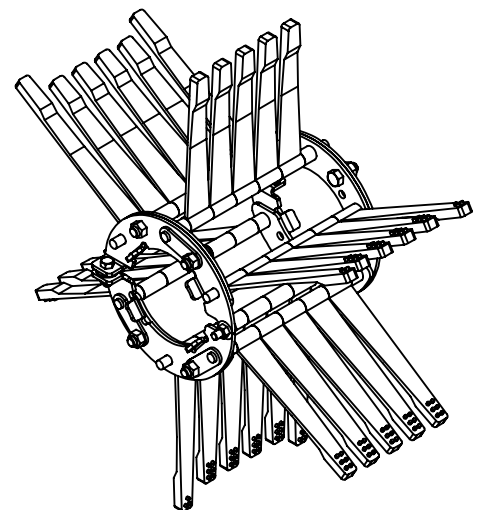
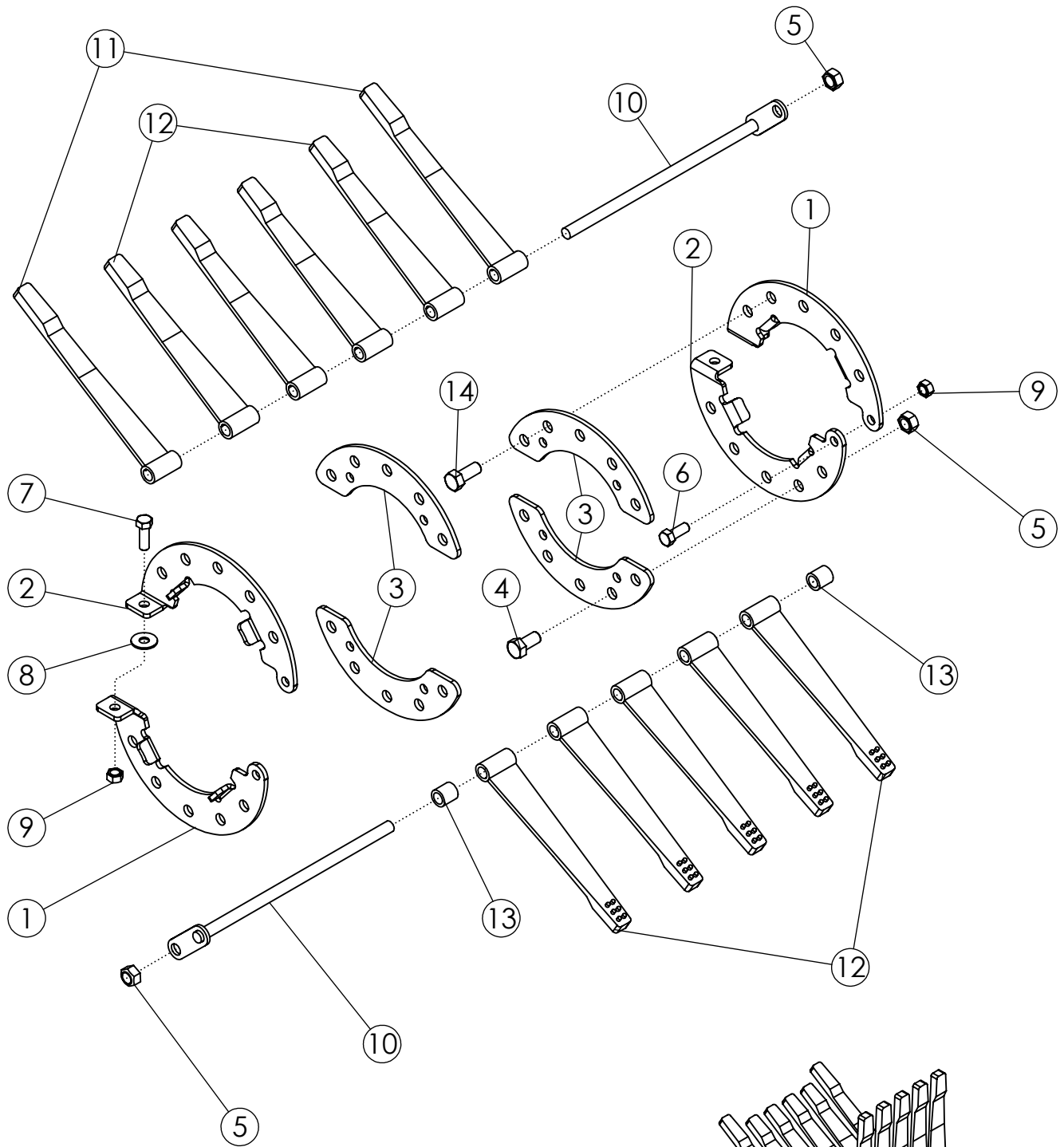

SWEEP/STUDED FLAIL #3 30" (69853)

ITEM	PART NO.	DESCRIPTION	QTY
1	52062	FLAIL RING LH - ZP	2
2	52061	FLAIL RING RH - ZP	2
3	58084	PLATE-REINFORCEMENT ZP	4
4	1032509	BOLT-HEX: .63 X 1.25 NC GR5 ZP	2
5	1016595	NUT-TOPLOCK: .63 NC GR5 ZP	8
6	1011606	BOLT-HEX: .50 X 1.25 NC GR5 ZP	2
7	1011607	BOLT-HEX: .50 X 1.50 NC GR5 ZP	2
8	1014443	WASHER-FLAT: .50 ZP	2
9	1027461	NUT-TOPLOCK: .50 NC GR5 ZP	4
10	305557	WLDMT-6 FLAIL ROD 13.875" ZP	6
11	52355	FLAIL-SWEEP 1 X 13.25	6
12	52356	FLAIL-STUDED 1 X 12	27
13	51549	SPACER-1"	6
14	1014349	BOLT-HEX: .63 X 1.50 NC GR5 ZP	6

SWEEP/TAPERED FLAIL #3 30" (68796)

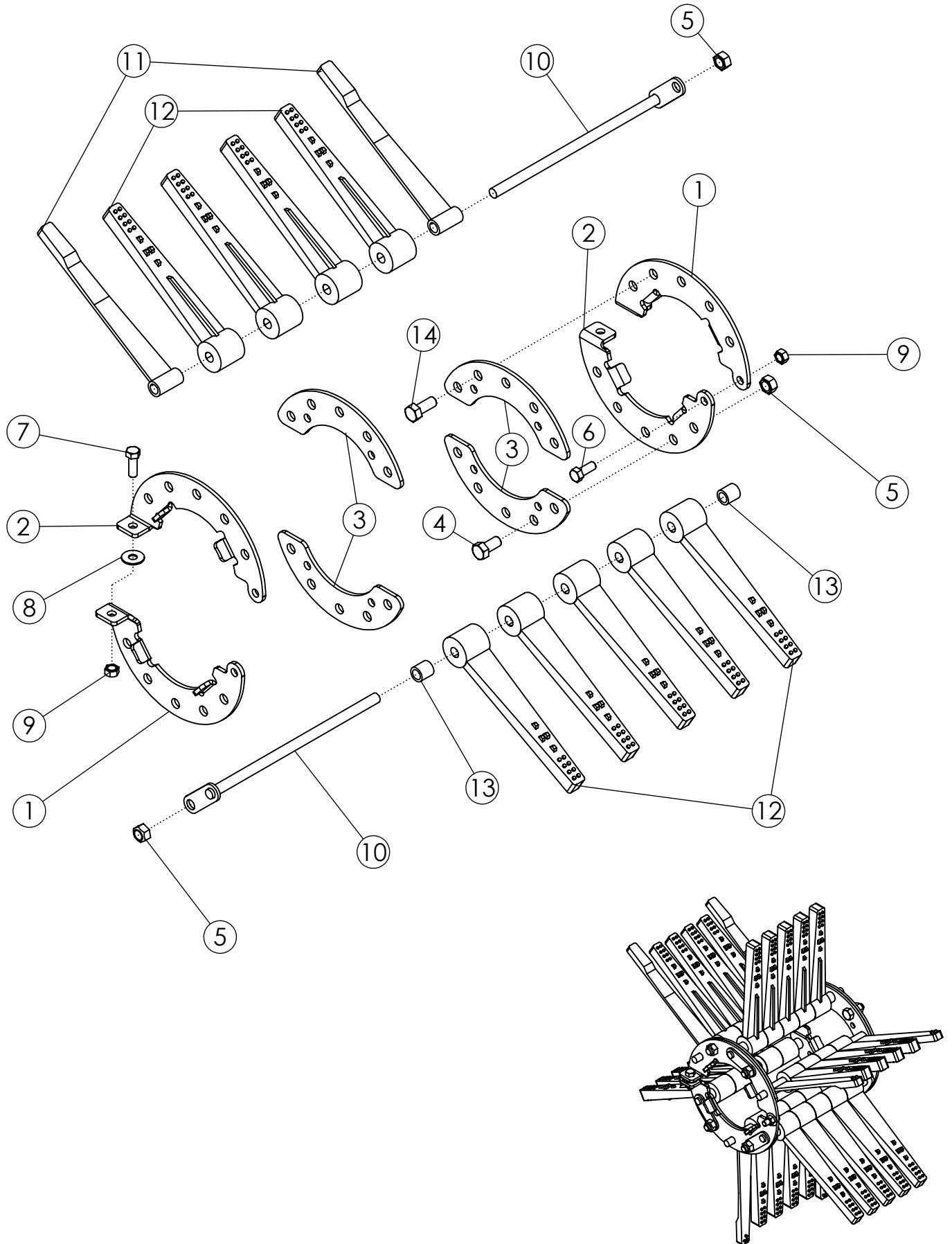

SWEEP/TAPERED FLAIL #3 30" (68796)

ITEM	PART NO.	DESCRIPTION	QTY
1	52062	FLAIL RING LH - ZP	2
2	52061	FLAIL RING RH - ZP	2
3	58084	PLATE-REINFORCEMENT ZP	4
4	1032509	BOLT-HEX: .63 X 1.25 NC GR5 ZP	2
5	1016595	NUT-TOPLOCK: .63 NC GR5 ZP	8
6	1011606	BOLT-HEX: .50 X 1.25 NC GR5 ZP	2
7	1011607	BOLT-HEX: .50 X 1.50 NC GR5 ZP	2
8	1014443	WASHER-FLAT: .50 ZP	2
9	1027461	NUT-TOPLOCK: .50 NC GR5 ZP	4
10	305557	WLDMT-6 FLAIL ROD 13.875" ZP	6
11	52355	FLAIL-SWEEP 1 X 13.25	6
12	307259	FLAIL-RUBBER 1 X 12 TAPERED	27
13	51549	SPACER-1"	6
14	1014349	BOLT-HEX: .63 X 1.50 NC GR5 ZP	6

FULL TAPERED FLAIL #3 22" (307563)

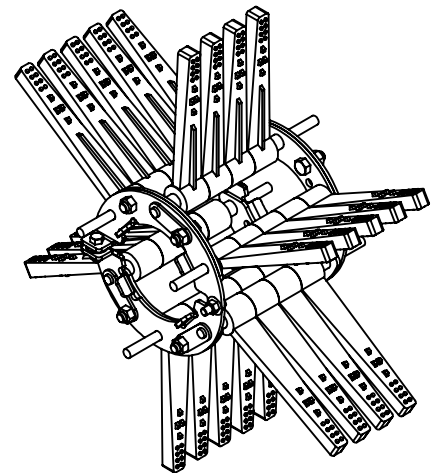
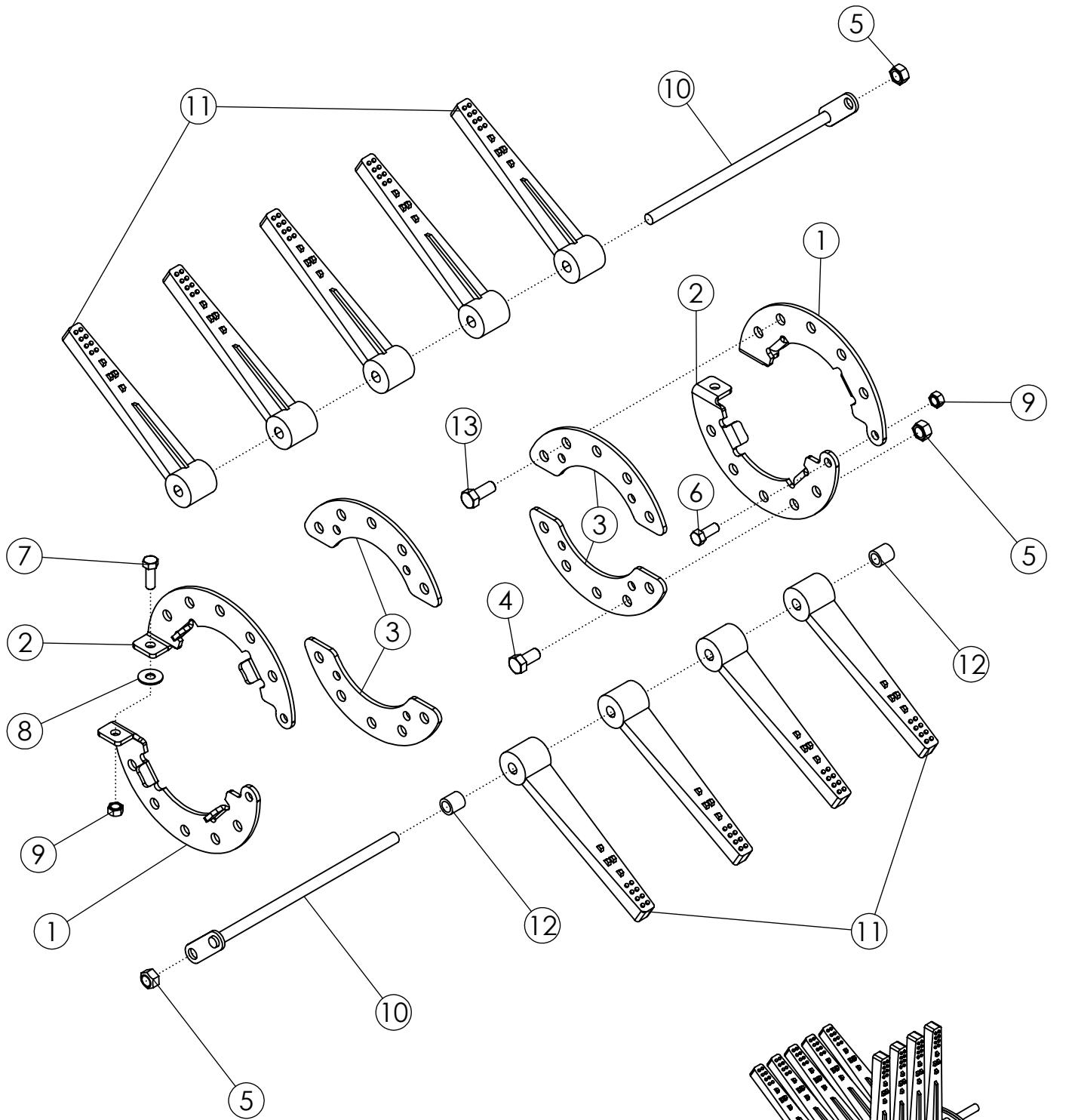

FULL TAPERED FLAIL #3 22" (307563)

ITEM	PART NO.	DESCRIPTION	QTY
1	52062	FLAIL RING LH - ZP	2
2	52061	FLAIL RING RH - ZP	2
3	58084	PLATE-REINFORCEMENT ZP	4
4	1032509	BOLT-HEX: .63 X 1.25 NC GR5 ZP	2
5	1016595	NUT-TOPLOCK: .63 NC GR5 ZP	8
6	1011606	BOLT-HEX: .50 X 1.25 NC GR5 ZP	2
7	1011607	BOLT-HEX: .50 X 1.50 NC GR5 ZP	2
8	1014443	WASHER-FLAT: .50 ZP	2
9	1027461	NUT-TOPLOCK: .50 NC GR5 ZP	4
10	305557	WLDMT-6 FLAIL ROD 13.875" ZP	6
11	307259	FLAIL-RUBBER 1 X 12 TAPERED	27
12	51549	SPACER-1"	6
13	1014349	BOLT-HEX: .63 X 1.50 NC GR5 ZP	6

STANDARD REAR STRUTS 11.2 X 24 22" (306001)

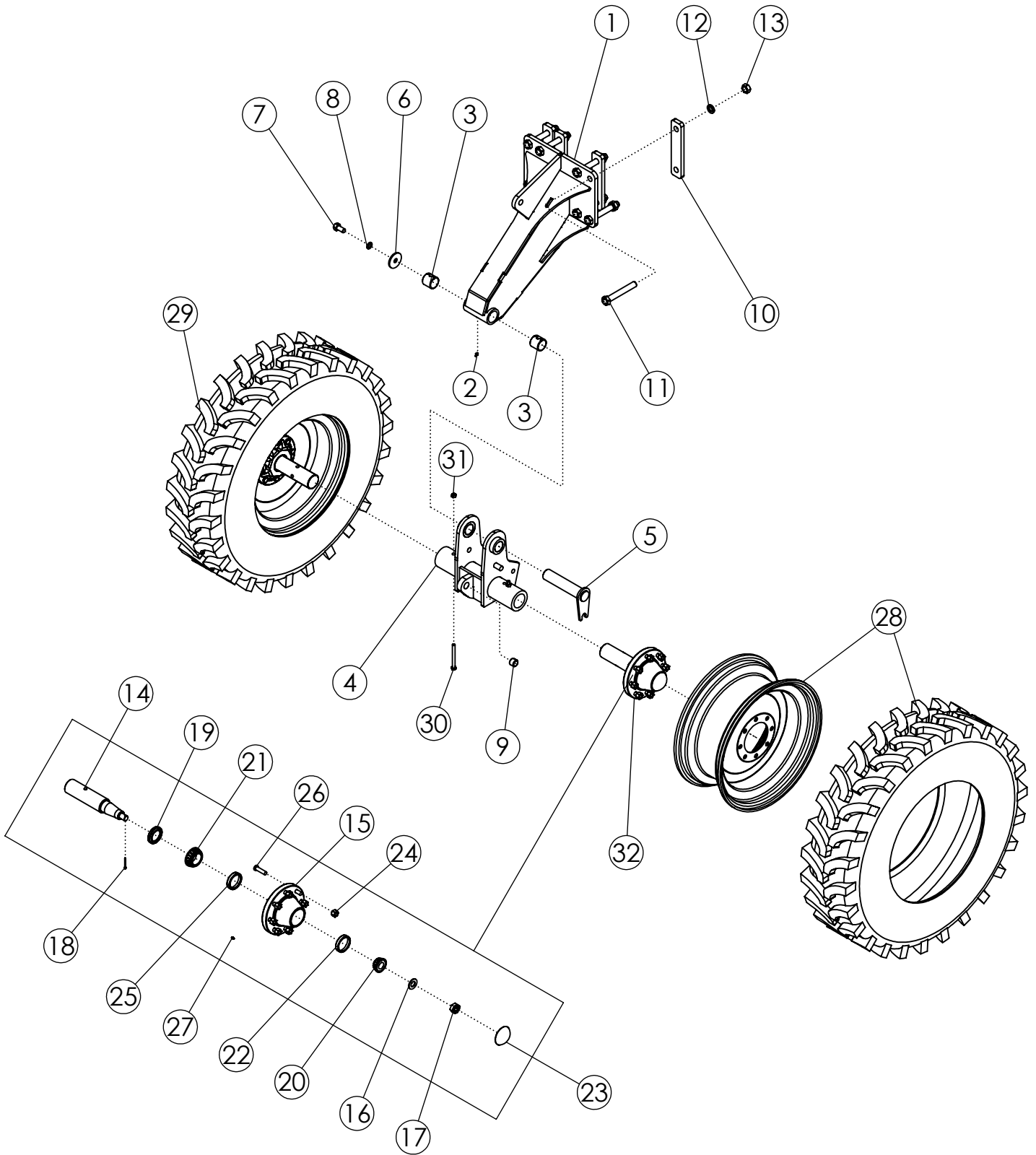

STANDARD REAR STRUTS 11.2 X 24 22" (306001)

ITEM	PART NO.	DESCRIPTION	QTY
1	306020	WLDMT-STRUT STANDARD PIVOT	2
2	1011748	ZERK-GREASE .25 UNF STRAIGHT	2
3	73466	BUSHING-SPRING 2.25 X 2.0 X 2.0 L	4
4	305561	WLDMT-SPINDLE RECEIVER 22"	2
5	305573	WLDMT-DEF STRUT FLAG PIN ZP	2
6	305575	PLATE-PIVOT POINT END CAP ZP	2
7	58367	BOLT-HEX: .75 X 1.50 NC GR5 ZP	2
8	1012061	WASHER-LOCK: .75 ZP	2
9	45572	BUSHING-SPRING 1.25 X 1 X 1	2
10	58408	BAR - BOLTING	8
11	1018839	BOLT-HEX: 1.00 X 7.00 NC GR8 ZP	16
12	1013539	WASHER-LOCK: 1.00 ZP	16
13	1012664	NUT-HEX: 1.00 NC GR2 ZP	16
14	52954	SPINDLE-STANDARD	4
15	53623	HUB-WHEEL 8 BOLT	4
16	1030728	WASHER-FLAT: SAE 1.00 ZP GR8	4
17	1030726	NUT-SPINDLE: 1.00 NF NP	4
18	1030797	PIN-COTTER: .19 X 1.75 NP	4
19	53619	SEAL 7044-116	4
20	53620	BEARING CONE-OUTER	4
21	53621	BEARING CONE-INNER	4
22	53622	BEARING CUP-INNER	4
23	53624	CAP-HUB	4
24	53625	NUT-WHEEL .625-18NF	32
25	52243	BEARING CUP-OUTER	4
26	54393	STUD-HUB BOLT 7600-6	32
27	301490	SELF TAPPING GREASE FITTING	4
28	56986	TIRE-MNTD: 11.2-24 10 PLY R1 TITAN HTL RH	2
29	63992	TIRE-MNTD: 11.2-24 10 PLY R1 TITAN HTL LH	2
30	1011618	BOLT-HEX: .50 X 5.00 NC GR5 ZP	4
31	1027461	NUT-TOPLOCK: .50 NC GR5 ZP	4
32	53167	ASSY-HUB & SPINDLE: 8 BOLT W/ZERK	4

STANDARD REAR STRUTS 11.2 X 24 44" (306002)

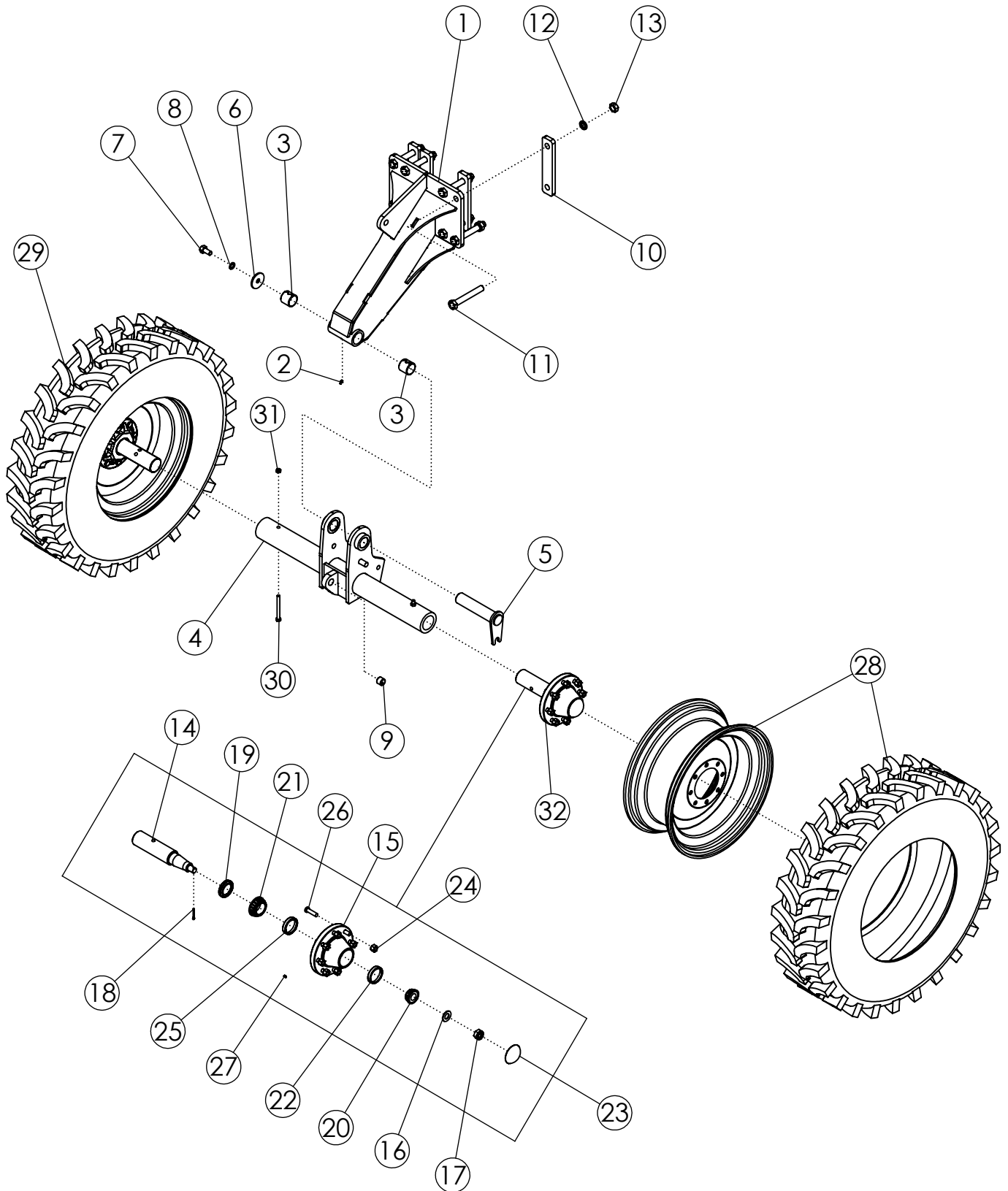

STANDARD REAR STRUTS 11.2 X 24 44" (306002)

ITEM	PART NO.	DESCRIPTION	QTY
1	306020	WLDMT-STRUT STANDARD PIVOT	2
2	1011748	ZERK-GREASE .25 UNF STRAIGHT	2
3	73466	BUSHING-SPRING 2.25 X 2.0 X 2.0 L	4
4	305562	WLDMT-SPINDLE RECEIVER 44"	2
5	305573	WLDMT-DEF STRUT FLAG PIN ZP	2
6	305575	PLATE-PIVOT POINT END CAP ZP	2
7	58367	BOLT-HEX: .75 X 1.50 NC GR5 ZP	2
8	1012061	WASHER-LOCK: .75 ZP	2
9	45572	BUSHING-SPRING 1.25 X 1 X 1	2
10	58408	BAR - BOLTING	8
11	1018839	BOLT-HEX: 1.00 X 7.00 NC GR8 ZP	16
12	1013539	WASHER-LOCK: 1.00 ZP	16
13	1012664	NUT-HEX: 1.00 NC GR2 ZP	16
14	52954	SPINDLE-STANDARD	4
15	53623	HUB-WHEEL 8 BOLT	4
16	1030728	WASHER-FLAT: SAE 1.00 ZP GR8	4
17	1030726	NUT-SPINDLE: 1.00 NF NP	4
18	1030797	PIN-COTTER: .19 X 1.75 NP	4
19	53619	SEAL 7044-116	4
20	53620	BEARING CONE-OUTER	4
21	53621	BEARING CONE-INNER	4
22	53622	BEARING CUP-INNER	4
23	53624	CAP-HUB	4
24	53625	NUT-WHEEL .625-18NF	32
25	52243	BEARING CUP-OUTER	4
26	54393	STUD-HUB BOLT 7600-6	32
27	301490	SELF TAPPING GREASE FITTING	4
28	56986	TIRE-MNTD: 11.2-24 10 PLY R1 TITAN HTL RH	2
29	63992	TIRE-MNTD: 11.2-24 10 PLY R1 TITAN HTL LH	2
30	1011618	BOLT-HEX: .50 X 5.00 NC GR5 ZP	4
31	1027461	NUT-TOPLOCK: .50 NC GR5 ZP	4
32	53167	ASSY-HUB & SPINDLE: 8 BOLT W/ZERK	4

STEERABLE REAR STRUTS 11.2 X 24 22" (305920)

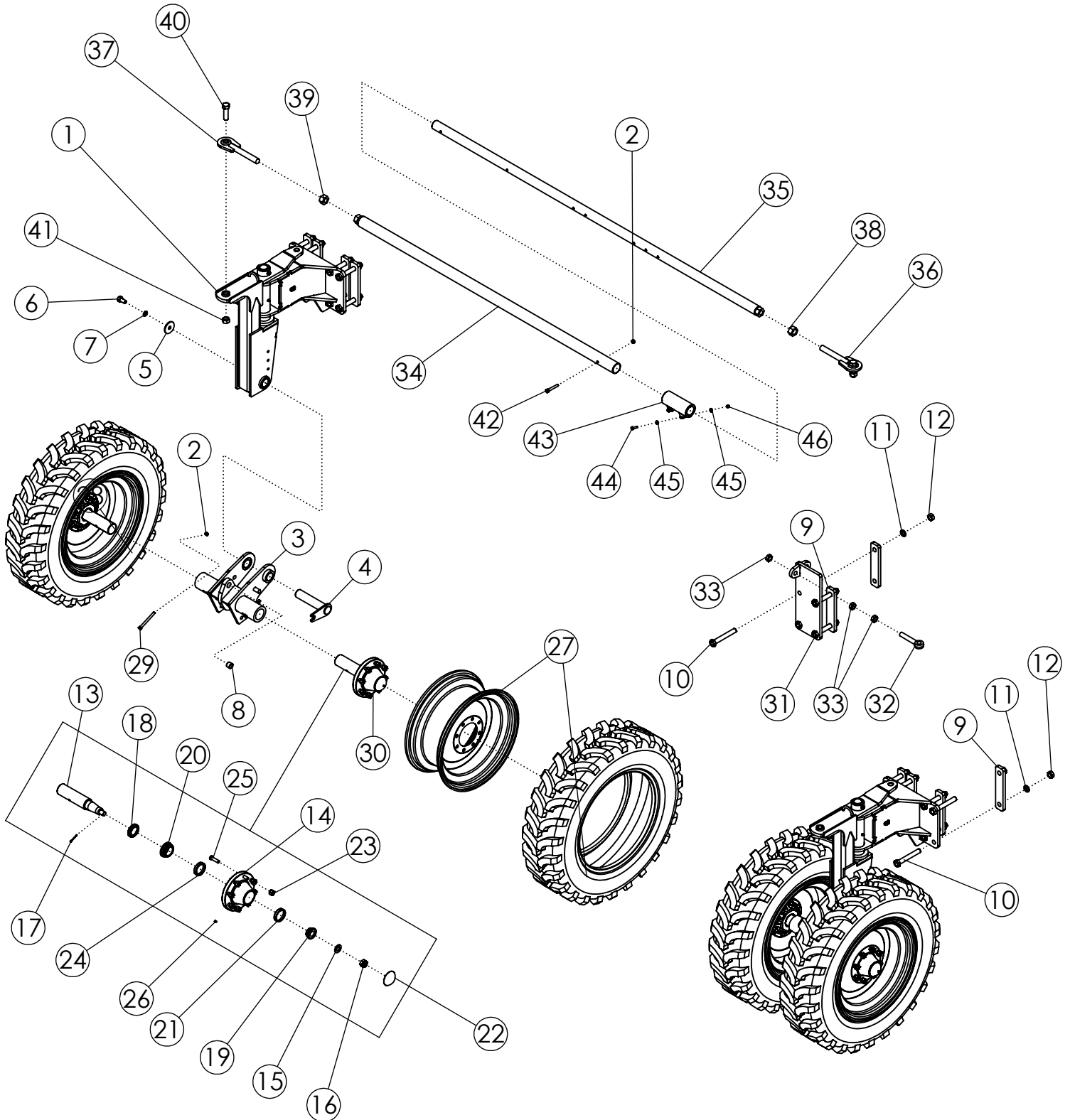

STEERABLE REAR STRUTS 11.2 X 24 22" (305920)

ITEM	PART NO.	DESCRIPTION	QTY
1	305924	ASSY-STEERABLE STRUT UPPER DLS	2
2	1027461	NUT-TOPLOCK: .50 NC GR5 ZP	5
3	305561	WLDMT-SPINDLE RECEIVER 22"	2
4	305573	WLDMT-DEF STRUT FLAG PIN ZP	2
5	305575	PLATE-PIVOT POINT END CAP ZP	2
6	58367	BOLT-HEX: .75 X 1.50 NC GR5 ZP	2
7	1012061	WASHER-LOCK: .75 ZP	2
8	45572	BUSHING-SPRING 1.25 X 1 X 1	2
9	58408	BAR - BOLTING	10
10	1018839	BOLT-HEX: 1.00 X 7.00 NC GR8 ZP	20
11	1013539	WASHER-LOCK: 1.00 ZP	20
12	1012664	NUT-HEX: 1.00 NC GR2 ZP	20
13	52954	SPINDLE-STANDARD	4
14	53623	HUB-WHEEL 8 BOLT	4
15	1030728	WASHER-FLAT: SAE 1.00 ZP GR8	4
16	1030726	NUT-SPINDLE: 1.00 NF NP	4
17	1030797	PIN-COTTER: .19 X 1.75 NP	4
18	53619	SEAL 7044-116	4
19	53620	BEARING CONE-OUTER	4
20	53621	BEARING CONE-INNER	4
21	53622	BEARING CUP-INNER	4
22	53624	CAP-HUB	4
23	53625	NUT-WHEEL .625-18NF	32
24	52243	BEARING CUP-OUTER	4
25	54393	STUD-HUB BOLT 7600-6	32
26	301490	SELF TAPPING GREASE FITTING	4
27	56986	TIRE-MNTD: 11.2-24 10 PLY R1 TITAN HTL RH	2
28	63992	TIRE-MNTD: 11.2-24 10 PLY R1 TITAN HTL LH	2
29	1011618	BOLT-HEX: .50 X 5.00 NC GR5 ZP	4
30	53167	ASSY-HUB & SPINDLE: 8 BOLT W/ZERK	4
31	306732	WLDMT-CYLINDER BRACKET ADJ	1
32	62081	BOLT-EYEBOLT: 1.00 X 6.00 ZP GR8	1
33	1026880	NUT-JAM: 1.00 NC GR2 ZP	3
34	306577	WLDMT-TIE ROD 85" FEMALE	1
35	306581	WLDMT-TIE ROD 107" MALE	1
36	58186	WLDMT-TIE ROD END RH	1

CONTINUED

STEERABLE REAR STRUTS 11.2 X 24 22" (305920)

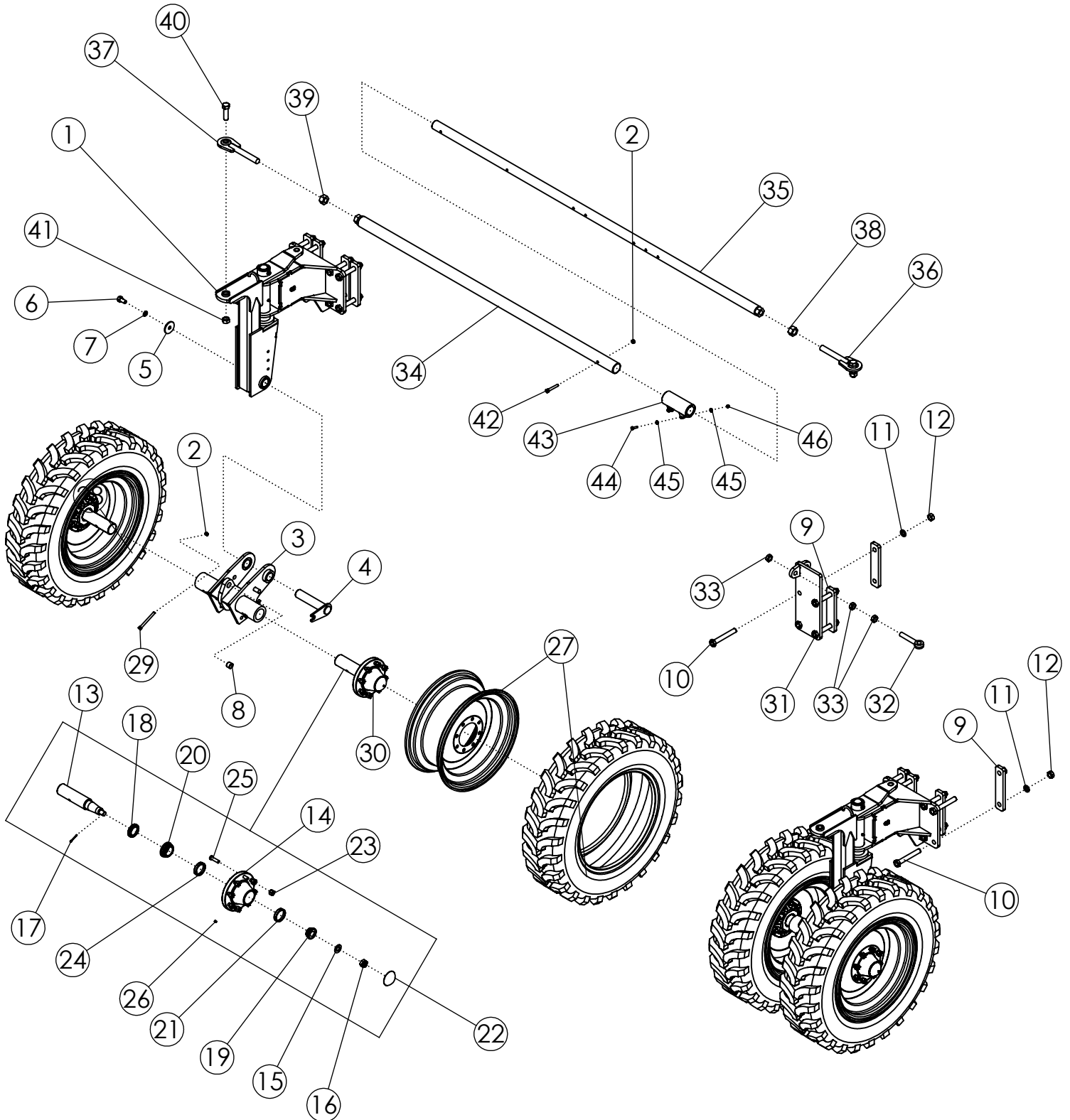

STEERABLE REAR STRUTS 11.2 X 24 22" (305920) (CONTINUED)

ITEM	PART NO.	DESCRIPTION	QTY
37	58203	WLDMT-TIE ROD END LH	1
38	1011621	NUT-HEX: 1.25 NC GR2 ZP RH	1
39	1030729	NUT-HEX: 1.25 NC GR2 ZP LH	1
40	1032276	BOLT-HEX: 1.00 X 3.50 NC GR8 ZP	2
41	1016969	NUT-TOPLOCK: 1.00 NC GR8 ZP	2
42	1017719	BOLT-HEX: .50 X 3.25 NC GR5 ZP	1
43	306579	WLDMT-TIE ROD CLAMP	1
44	1011602	BOLT-HEX: .38 X 1.50 NC GR5 ZP	2
45	1014608	WASHER-FLAT: SAE .38 ZP	4
46	1016999	NUT-TOPLOCK: .38 NC GR5 ZP	2

STEERABLE REAR STRUTS 11.2 X 24 44" (305921)

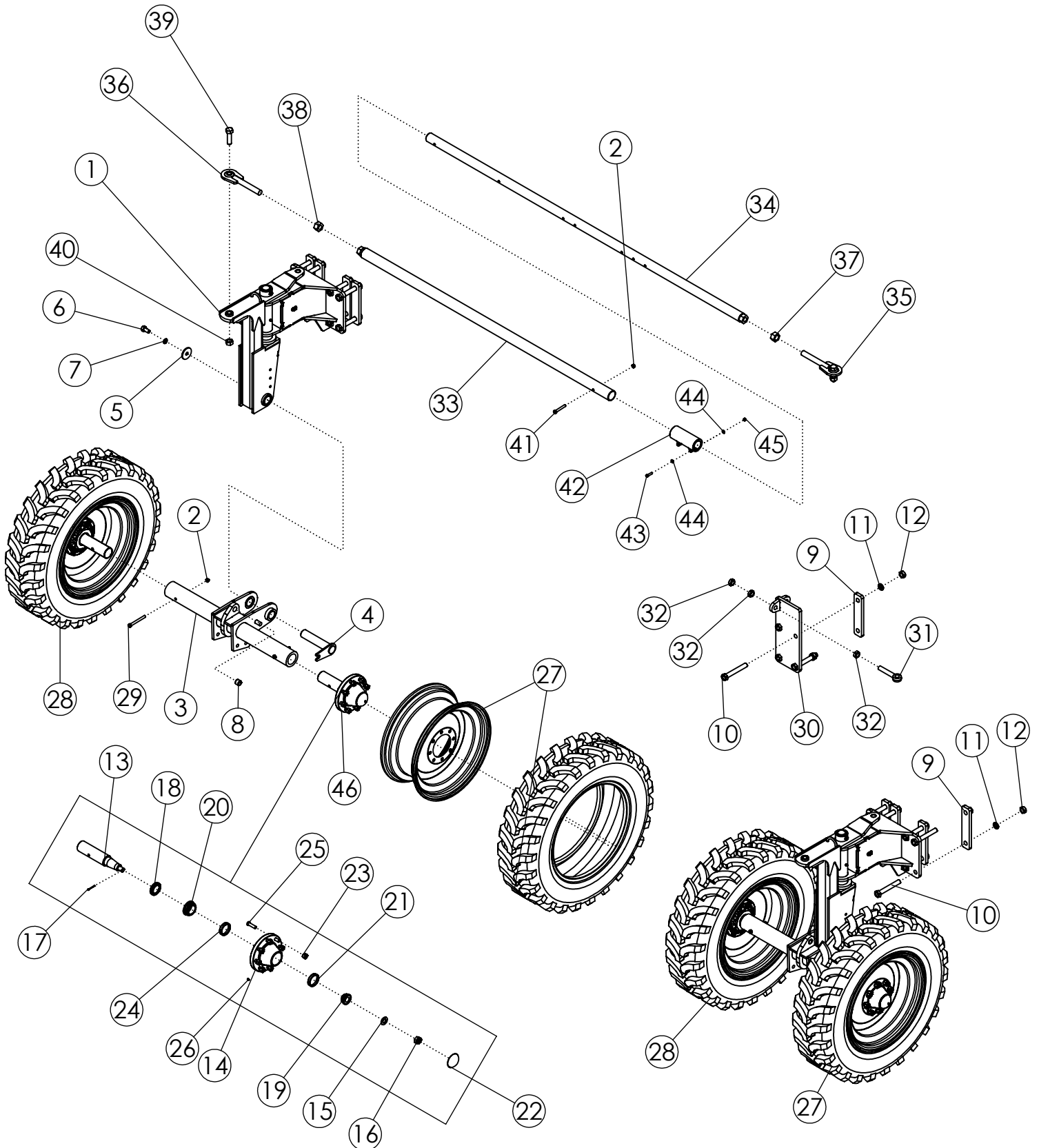

STEERABLE REAR STRUTS 11.2 X 24 44" (305921)

ITEM	PART NO.	DESCRIPTION	QTY
1	305924	ASSY-STEERABLE STRUT UPPER DLS	2
2	1027461	NUT-TOPLOCK: .50 NC GR5 ZP	5
3	305562	WLDMT-SPINDLE RECEIVER 44"	2
4	305573	WLDMT-DEF STRUT FLAG PIN ZP	2
5	305575	PLATE-PIVOT POINT END CAP ZP	2
6	58367	BOLT-HEX: .75 X 1.50 NC GR5 ZP	2
7	1012061	WASHER-LOCK: .75 ZP	2
8	45572	BUSHING-SPRING 1.25 X 1 X 1	2
9	58408	BAR - BOLTING	10
10	1018839	BOLT-HEX: 1.00 X 7.00 NC GR8 ZP	20
11	1013539	WASHER-LOCK: 1.00 ZP	20
12	1012664	NUT-HEX: 1.00 NC GR2 ZP	20
13	52954	SPINDLE-STANDARD	4
14	53623	HUB-WHEEL 8 BOLT	4
15	1030728	WASHER-FLAT: SAE 1.00 ZP GR8	4
16	1030726	NUT-SPINDLE: 1.00 NF NP	4
17	1030797	PIN-COTTER: .19 X 1.75 NP	4
18	53619	SEAL 7044-116	4
19	53620	BEARING CONE-OUTER	4
20	53621	BEARING CONE-INNER	4
21	53622	BEARING CUP-INNER	4
22	53624	CAP-HUB	4
23	53625	NUT-WHEEL .625-18NF	32
24	52243	BEARING CUP-OUTER	4
25	54393	STUD-HUB BOLT 7600-6	32
26	301490	SELF TAPPING GREASE FITTING	4
27	56986	TIRE-MNTD: 11.2-24 10 PLY R1 TITAN HTL RH	2
28	63992	TIRE-MNTD: 11.2-24 10 PLY R1 TITAN HTL LH	2
29	1011618	BOLT-HEX: .50 X 5.00 NC GR5 ZP	4
30	306732	WLDMT-CYLINDER BRACKET ADJ	1
31	62081	BOLT-EYEBOLT: 1.00 X 6.00 ZP GR8	1
32	1026880	NUT-JAM: 1.00 NC GR2 ZP	3
33	306577	WLDMT-TIE ROD 85" FEMALE	1
34	306581	WLDMT-TIE ROD 107" MALE	1
35	58186	WLDMT-TIE ROD END RH	1
36	58203	WLDMT-TIE ROD END LH	1

CONTINUED

STEERABLE REAR STRUTS 11.2 X 24 44" (305921)

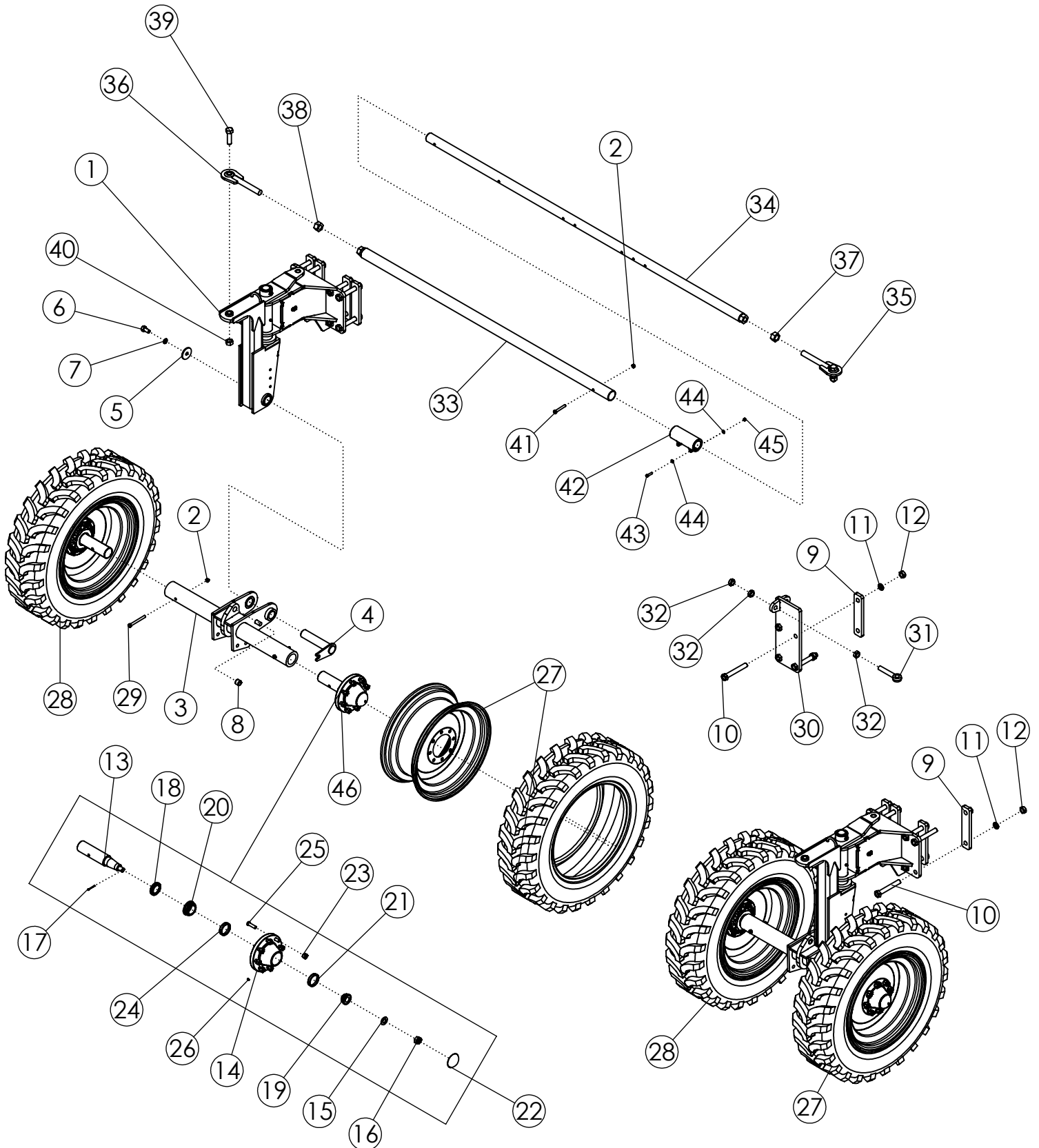

STEERABLE REAR STRUTS 11.2 X 24 44" (305921) (CONTINUED)

ITEM	PART NO.	DESCRIPTION	QTY
37	1011621	NUT-HEX: 1.25 NC GR2 ZP RH	1
38	1030729	NUT-HEX: 1.25 NC GR2 ZP LH	1
39	1032276	BOLT-HEX: 1.00 X 3.50 NC GR8 ZP	2
40	1016969	NUT-TOPLOCK: 1.00 NC GR8 ZP	2
41	1017719	BOLT-HEX: .50 X 3.25 NC GR5 ZP	1
42	306579	WLDMT-TIE ROD CLAMP	1
43	1011602	BOLT-HEX: .38 X 1.50 NC GR5 ZP	2
44	1014608	WASHER-FLAT: SAE .38 ZP	4
45	1016999	NUT-TOPLOCK: .38 NC GR5 ZP	2
46	53167	ASSY-HUB & SPINDLE: 8 BOLT W/ZERK	4

STEERABLE STRUT ASSEMBLY (305924)

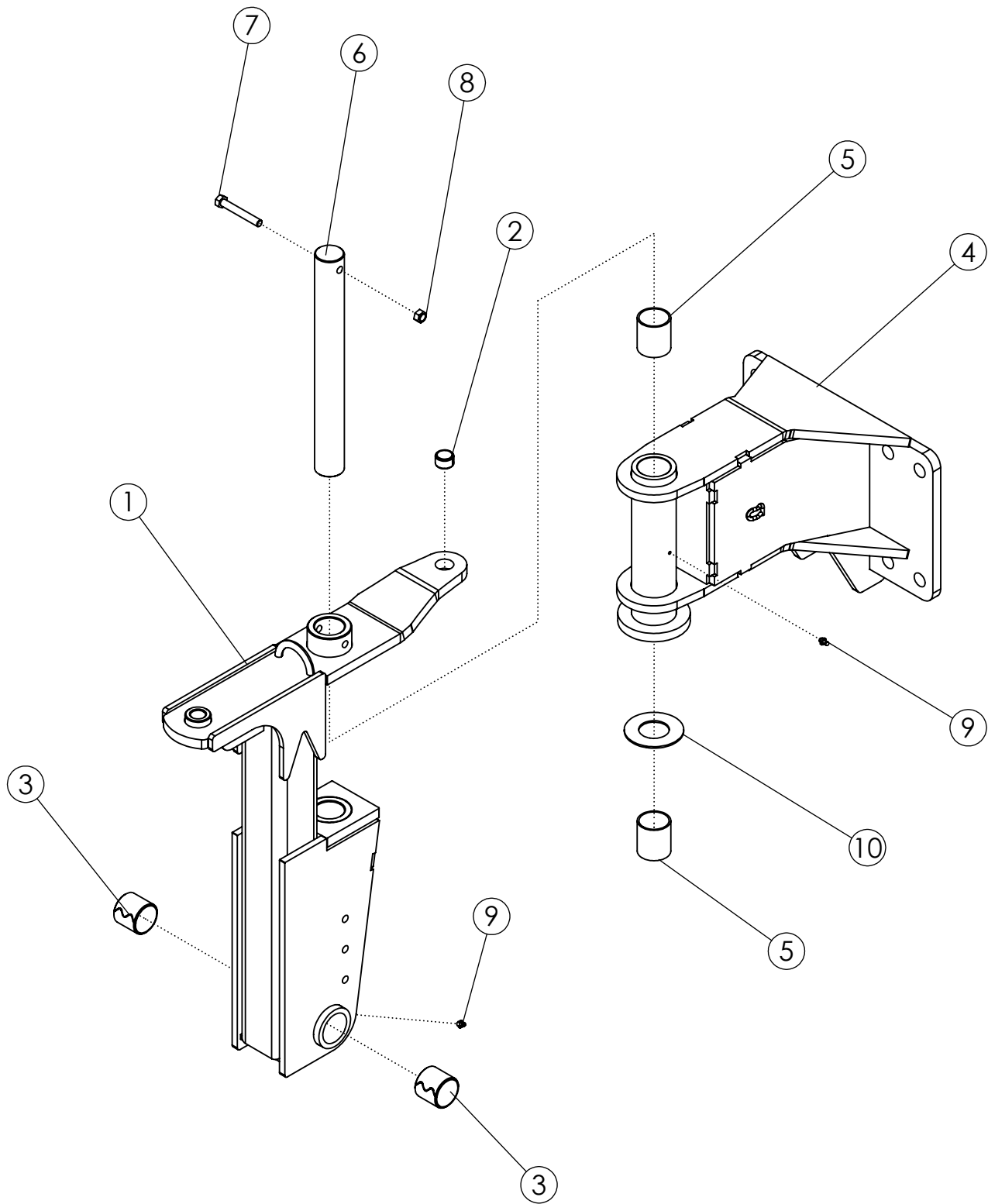

STEERABLE STRUT ASSEMBLY (305924)

ITEM	PART NO.	DESCRIPTION	QTY
1	305560	WLDMT-STRUT UPPER	1
2	307240	SPRING BUSHING 1.25 X 1 X 0.75	1
3	73466	BUSHING-SPRING 2.25 X 2.0 X 2.0 L	2
4	305925-1	WLDMT-PIVOT MOUNT DLS	1
5	59204	BUSHING-BORED 2.5 X 2.015	2
6	58274	SHAFT-STRUT PIVOT	1
7	1011612	BOLT-HEX: .50 X 3.50 GR5 ZP	1
8	1027461	NUT-TOPLOCK: .50 NC GR5 ZP	1
9	1011748	ZERK-GREASE .25 UNF STRAIGHT	2
10	305586	BUSHING-THRUST 2.062 X 4.00 X .125	1

OSC STANDARD REAR STRUTS 11.2 X 24 44" (69449)

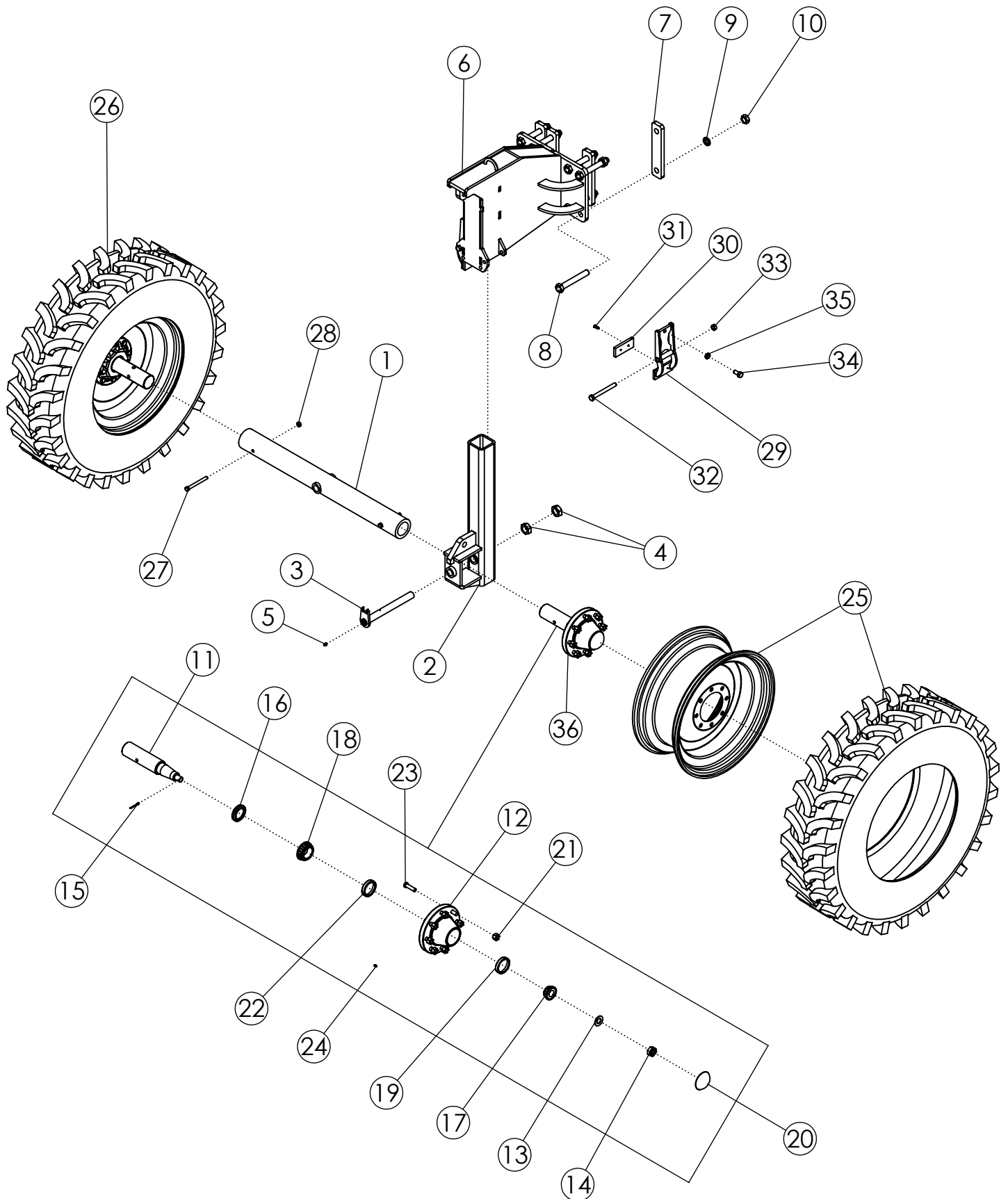

OSC STANDARD REAR STRUTS 11.2 X 24 44" (69449)

ITEM	PART NO.	DESCRIPTION	QTY
1	69438	WLDMT-OSC TUBE	2
2	69444	WLDMT-OSC STRUT	2
3	69446	WLDMT-FLAG PIN ZP	2
4	65864	NUT-JAM: 1.25 NF GR2 ZP	4
5	1011748	ZERK-GREASE .25 UNF STRAIGHT	2
6	68332	WLDMT-STD STRUT UPPER	2
7	58408	BAR - BOLTING	8
8	1018839	BOLT-HEX: 1.00 X 7.00 NC GR8 ZP	16
9	1013539	WASHER-LOCK: 1.00 ZP	16
10	1012664	NUT-HEX: 1.00 NC GR2 ZP	16
11	52954	SPINDLE-STANDARD	4
12	53623	HUB-WHEEL 8 BOLT	4
13	1030728	WASHER-FLAT: SAE 1.00 ZP GR8	4
14	1030726	NUT-SPINDLE: 1.00 NF NP	4
15	1030797	PIN-COTTER: .19 X 1.75 NP	4
16	53619	SEAL 7044-116	4
17	53620	BEARING CONE-OUTER	4
18	53621	BEARING CONE-INNER	4
19	53622	BEARING CUP-INNER	4
20	53624	CAP-HUB	4
21	53625	NUT-WHEEL .625-18NF	32
22	52243	BEARING CUP-OUTER	4
23	54393	STUD-HUB BOLT 7600-6	32
24	301490	SELF TAPPING GREASE FITTING	4
25	56986	TIRE-MNTD: 11.2-24 10 PLY R1 TITAN HTL RH	2
26	63992	TIRE-MNTD: 11.2-24 10 PLY R1 TITAN HTL LH	2
27	1011618	BOLT-HEX: .50 X 5.00 NC GR5 ZP	4
28	1027461	NUT-TOPLOCK: .50 NC GR5 ZP	4
29	69956	WLDMT- DEF STRUT CLAMP	4
30	69971	PLASTIC-STRUT CLAMP	4
31	69987	SCRWE-MACH: FH-TORX 1/4-20 X 1.00	8
32	1013068	BOLT-HEX: .63 X 6.00 NC GR5 ZP	4
33	1016595	NUT-TOPLOCK: .63 NC GR5 ZP	4
34	1030703	BOLT-HEX: .63 X 1.25 NF GR5 ZP	4
35	66336	NUT-JAM: .63 NF GR2 ZP	4
36	53167	ASSY-HUB & SPINDLE: 8 BOLT W/ZERK	4

OFFSET STEERABLE REAR STRUTS 11.2 X 24 22" (306004)

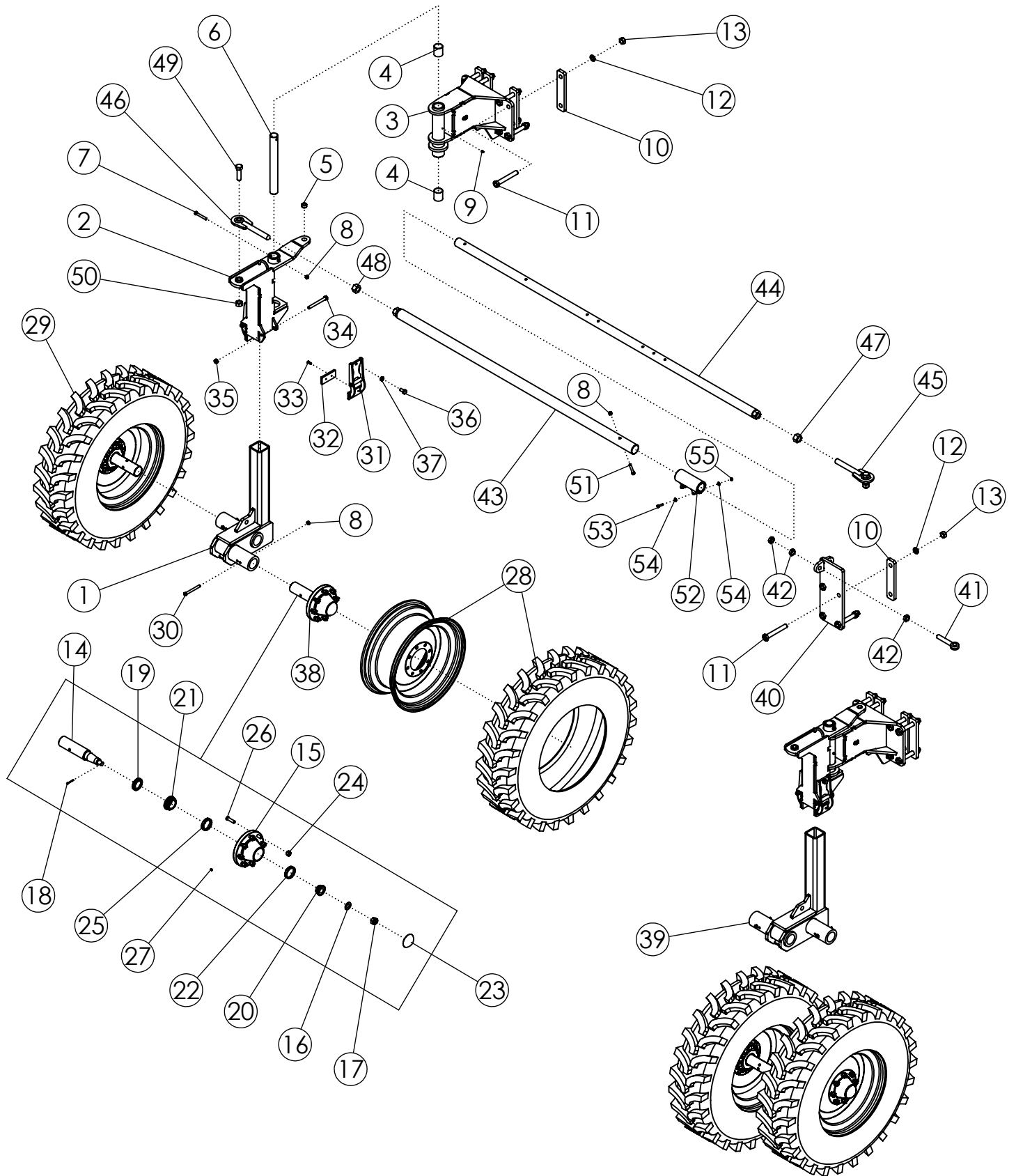

OFFSET STEERABLE REAR STRUTS 11.2 X 24 22" (306004)

ITEM	PART NO.	DESCRIPTION	QTY
1	305279	WLDMT-SPINDLE HOUSING- 8" OFFSET RH	1
2	68237	WLDMT-STEERABLE STRUT UPPER	2
3	305925-1	WLDMT-PIVOT MOUNT DLS	2
4	59204	BUSHING-BORED 2.5 X 2.015	4
5	307240	SPRING BUSHING 1.25 X 1 X 0.75	2
6	58274	SHAFT-STRUT PIVOT	2
7	1011612	BOLT-HEX: .50 X 3.50 GR5 ZP	2
8	1027461	NUT-TOPLOCK: .50 NC GR5 ZP	7
9	1011748	ZERK-GREASE .25 UNF STRAIGHT	2
10	58408	BAR - BOLTING	10
11	1018839	BOLT-HEX: 1.00 X 7.00 NC GR8 ZP	20
12	1013539	WASHER-LOCK: 1.00 ZP	20
13	1012664	NUT-HEX: 1.00 NC GR2 ZP	20
14	52954	SPINDLE-STANDARD	4
15	53623	HUB-WHEEL 8 BOLT	4
16	1030728	WASHER-FLAT: SAE 1.00 ZP GR8	4
17	1030726	NUT-SPINDLE: 1.00 NF NP	4
18	1030797	PIN-COTTER: .19 X 1.75 NP	4
19	53619	SEAL 7044-116	4
20	53620	BEARING CONE-OUTER	4
21	53621	BEARING CONE-INNER	4
22	53622	BEARING CUP-INNER	4
23	53624	CAP-HUB	4
24	53625	NUT-WHEEL .625-18NF	32
25	52243	BEARING CUP-OUTER	4
26	54393	STUD-HUB BOLT 7600-6	32
27	301490	SELF TAPPING GREASE FITTING	4
28	56986	TIRE-MNTD: 11.2-24 10 PLY R1 TITAN HTL RH	2
29	63992	TIRE-MNTD: 11.2-24 10 PLY R1 TITAN HTL LH	2
30	1011618	BOLT-HEX: .50 X 5.00 NC GR5 ZP	4
31	69956	WLDMT- DEF STRUT CLAMP	4
32	69971	PLASTIC-STRUT CLAMP	4
33	69987	SCRWE-MACH: FH-TORX 1/4-20 X 1.00	8
34	1013068	BOLT-HEX: .63 X 6.00 NC GR5 ZP	4
35	1016595	NUT-TOPLOCK: .63 NC GR5 ZP	4
36	1030703	BOLT-HEX: .63 X 1.25 NF GR5 ZP	4

CONTINUED

OFFSET STEERABLE REAR STRUTS 11.2 X 24 22" (306004)

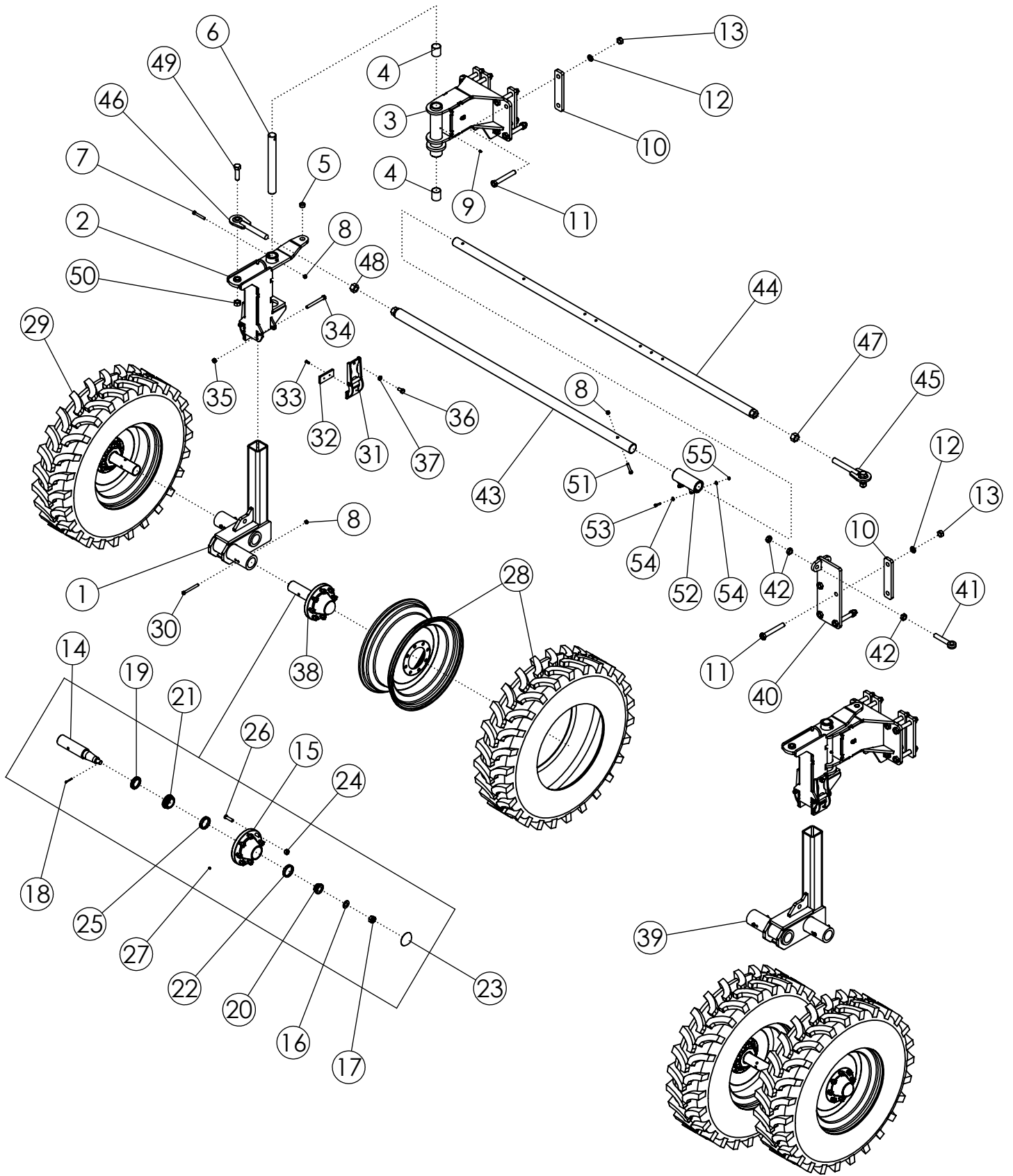

OFFSET STEERABLE REAR STRUTS 11.2 X 24 22" (306004) (CONTINUED)

ITEM	PART NO.	DESCRIPTION	QTY
37	66336	NUT-JAM: .63 NF GR2 ZP	4
38	53167	ASSY-HUB & SPINDLE: 8 BOLT W/ZERK	4
39	305280	WLDMT-SPINDLE HOUSING- 8" OFFSET LH	1
40	306732	WLDMT-CYLINDER BRACKET ADJ	1
41	62081	BOLT-EYEBOLT: 1.00 X 6.00 ZP GR8	1
42	1026880	NUT-JAM: 1.00 NC GR2 ZP	3
43	306577	WLDMT-TIE ROD 85" FEMALE	1
44	306581	WLDMT-TIE ROD 107" MALE	1
45	58186	WLDMT-TIE ROD END RH	1
46	58203	WLDMT-TIE ROD END LH	1
47	1011621	NUT-HEX: 1.25 NC GR2 ZP RH	1
48	1030729	NUT-HEX: 1.25 NC GR2 ZP LH	1
49	1011626	BOLT-HEX: 1.00 X 3.50 NC GR5 ZP	2
50	1016969	NUT-TOPLOCK: 1.00 NC GR8 ZP	2
51	1017719	BOLT-HEX: .50 X 3.25 NC GR5 ZP	1
52	306579	WLDMT-TIE ROD CLAMP	1
53	1011602	BOLT-HEX: .38 X 1.50 NC GR5 ZP	2
54	1014608	WASHER-FLAT: SAE .38 ZP	4
55	1016999	NUT-TOPLOCK: .38 NC GR5 ZP	2

STANDARD STEERING (305976)

ITEM	PART NO.	DESCRIPTION	QTY
1	58891	CYLINDER-HYDRAULIC 4 X 8" 3000	1
2	301315	SEAL KT-CYL 4 X 8, 4 X 10 3000PSI	
3	65326	STOP-CYLINDER 4" (SILVER)	1
4	307195	PLATE-STEERING DOGBONE UNIVERSAL	1

CENTERING STEERING (305996)

ITEM	PART NO.	DESCRIPTION	QTY
1	69200	CYLINDER-HYD 3X4 4PORT 24.5 CLOSED	1
2	305293	KT-CYLINDER SEALS (62344/69200) (RAM INDUS)	
3	307800	KT-CYLINDER SEALS (62344/69200) (CTD)	
4	69167	PIN-CYLINDER W/CLIPS 1.00 X 2.25	2
5	304187	ASSY-TRACTOR HYD COUPLERS (BLUE)	1
6	307195	PLATE-STEERING DOGBONE UNIVERSAL	1

ROWFINDER ASSEMBLY (306865)

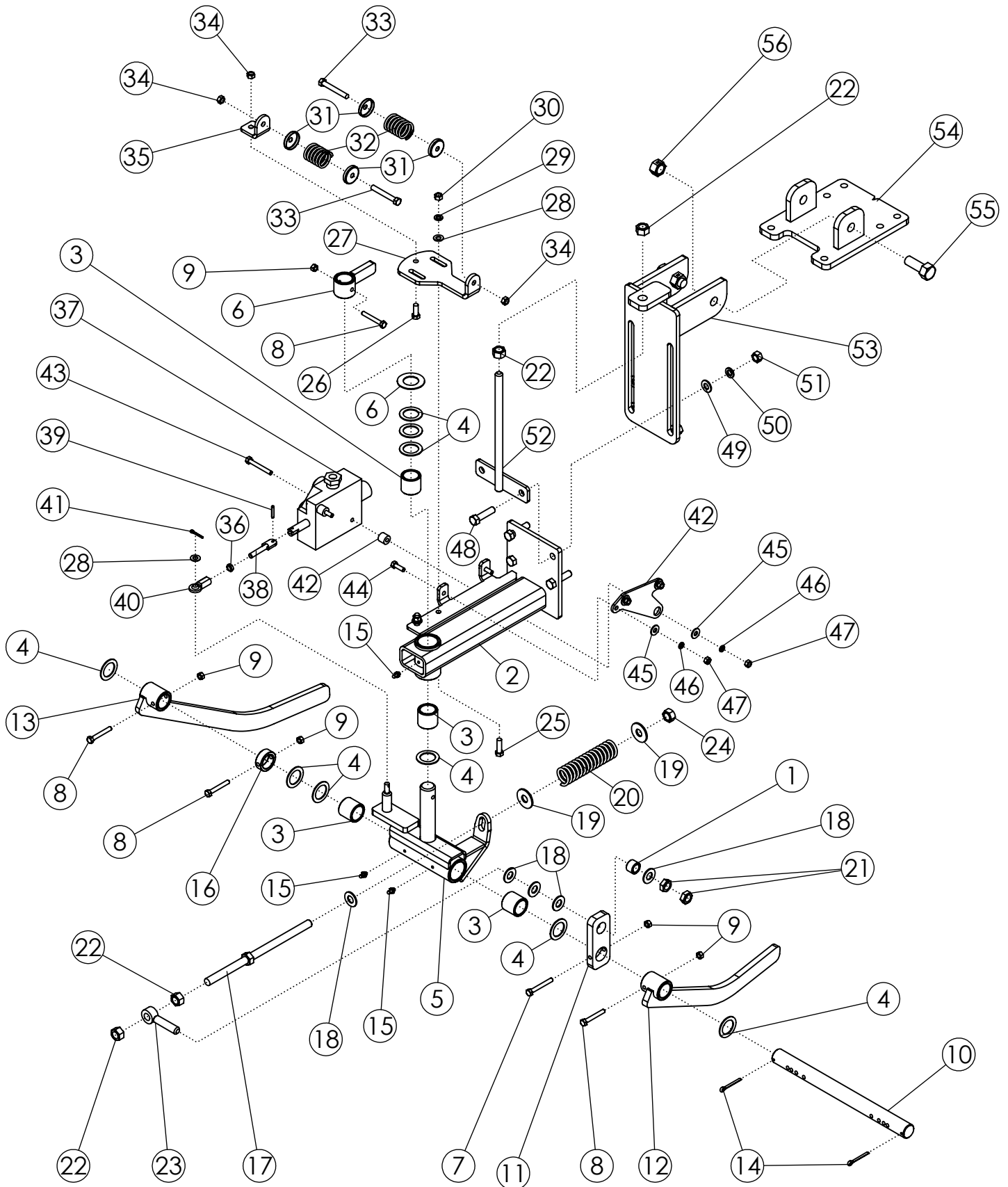

ROWFINDER ASSEMBLY (306865)

ITEM	PART NO.	DESCRIPTION	QTY
1	52567	BUSHING-ZP	1
2	62519	WLDMT-ROW FINDER MAIN FRAME	1
3	56939	BUSHING-OILITE: 1.25 X 1.625 X 1.50L	4
4	55206	BUSHING-MACH: 1.25 NR 14GA NP	9
5	56950	WLDMT - SWIVEL	1
6	51130	WLDMT-FLIPPER	1
7	301748	BOLT-HEX: .31 X 2.50 NC GR8 ZP	1
8	301258	BOLT-HEX: .31 X 2.25 NC GR8 ZP	4
9	301749	NUT-TOPLOCK: .31 NC GR8 ZP	5
10	51690	SHAFT-ROW FINDER ZP	1
11	52566	TENSIONER ARM	1
12	51131	WLDMT-SENSOR ARM LH	1
13	52564	WLDMT-SENSOR ARM RH	1
14	1030797	PIN-COTTER: .19 X 1.75 NP	2
15	1011748	ZERK-GREASE .25 UNF STRAIGHT	3
16	51137	COLLAR	1
17	52565	ADJUSTMENT BOLT	1
18	1013004	WASHER-FLAT: SAE .63 ZP	5
19	1013024	WASHER-FLAT: .63 ZP	2
20	51692	SPRING: .207 X 1.4375 OD X 6" 15 COILS	1
21	1026259	NUT-JAM: .63 NC GR2 ZP	2
22	1011578	NUT-HEX: .63 NC GR2 ZP	4
23	51691	EYEBOLT .63 X 3.25 ZP	1
24	1016595	NUT-TOPLOCK: .63 NC GR5 ZP	1
25	1011601	BOLT-HEX: .38 X 1.25 NC GR5 ZP	2
26	1011600	BOLT-HEX: .38 X 1.00 NC GR5 ZP	1
27	51129	PLATE-ADJUSTMENT	1
28	1014608	WASHER-FLAT: SAE .38 ZP	3
29	1011586	WASHER-LOCK: .38 ZP	2
30	1011576	NUT-HEX: .38 NC GR2 ZP	2
31	52582	SPRING CAP	4
32	51689	SPRING-ROW FINDER PAINTED	2
33	1019828	BOLT-HEX: .38 X 2.75 NC GR5 ZP	2
34	1016999	NUT-TOPLOCK: .38 NC GR5 ZP	3
35	51128	SPRING PLATE	1
36	1030792	NUT-JAM: .38 NF GR2 ZP	1

CONTINUED

ROWFINDER ASSEMBLY (306865)

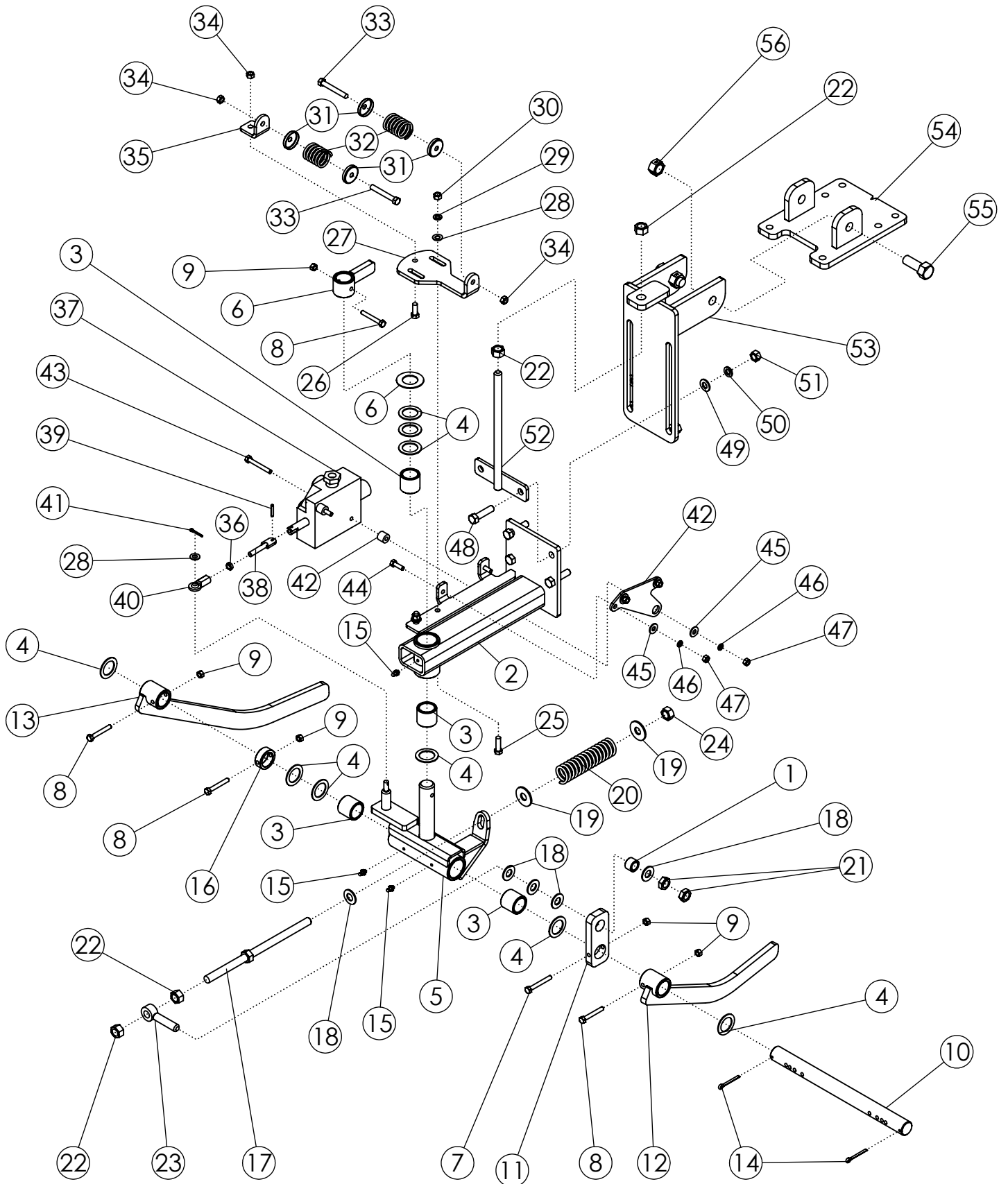

ROWFINDER ASSEMBLY (306865) (CONTINUED)

ITEM	PART NO.	DESCRIPTION	QTY
37	306698	VALVE-ROWFINDER POWER BEYOND	1
38	301750	WLDMT-STUD RF LONG ZP	1
39	64157	PIN-ROLL: .19 X 1.125 ZP	1
40	51136	UNIBALL COUPLING	1
41	1029137	PIN-COTTER: .13X 1.00 ZP	1
42	306854	WLDMT-R/F MNT PB	1
43	1027258	BOLT-HEX: .31 X 2.50 NC GR5 ZP	2
44	1011598	BOLT-HEX: .31 X 1.00 NC GR5 ZP	2
45	1011583	WASHER-FLAT: .31 ZP	4
46	1029115	WASHER-LOCK: .31 ZP	4
47	1011575	NUT-HEX: .31 NC GR2 ZP	4
48	1011609	BOLT-HEX: .50 X 2.00 NC GR5 ZP	4
49	1011584	WASHER-FLAT: SAE .50 ZP	4
50	1011581	WASHER-LOCK: .50 ZP	4
51	1011577	NUT-HEX: .50 NC GR2 ZP	4
52	62882	WLDMT-TIGHTENER 11.125" ZP	1
53	52181	WLDMT-BRACKET	1
54	301662	WLDMT-ROW FINDER BRACKET UNIVERSAL	1
55	1012060	BOLT-HEX: .75 X 2.00 NC GR5 ZP	2
56	1013537	NUT-CENTERLOCK: .75 NC ZP	2

ROWFINDER SCALPER MOUNT (306005/307539)

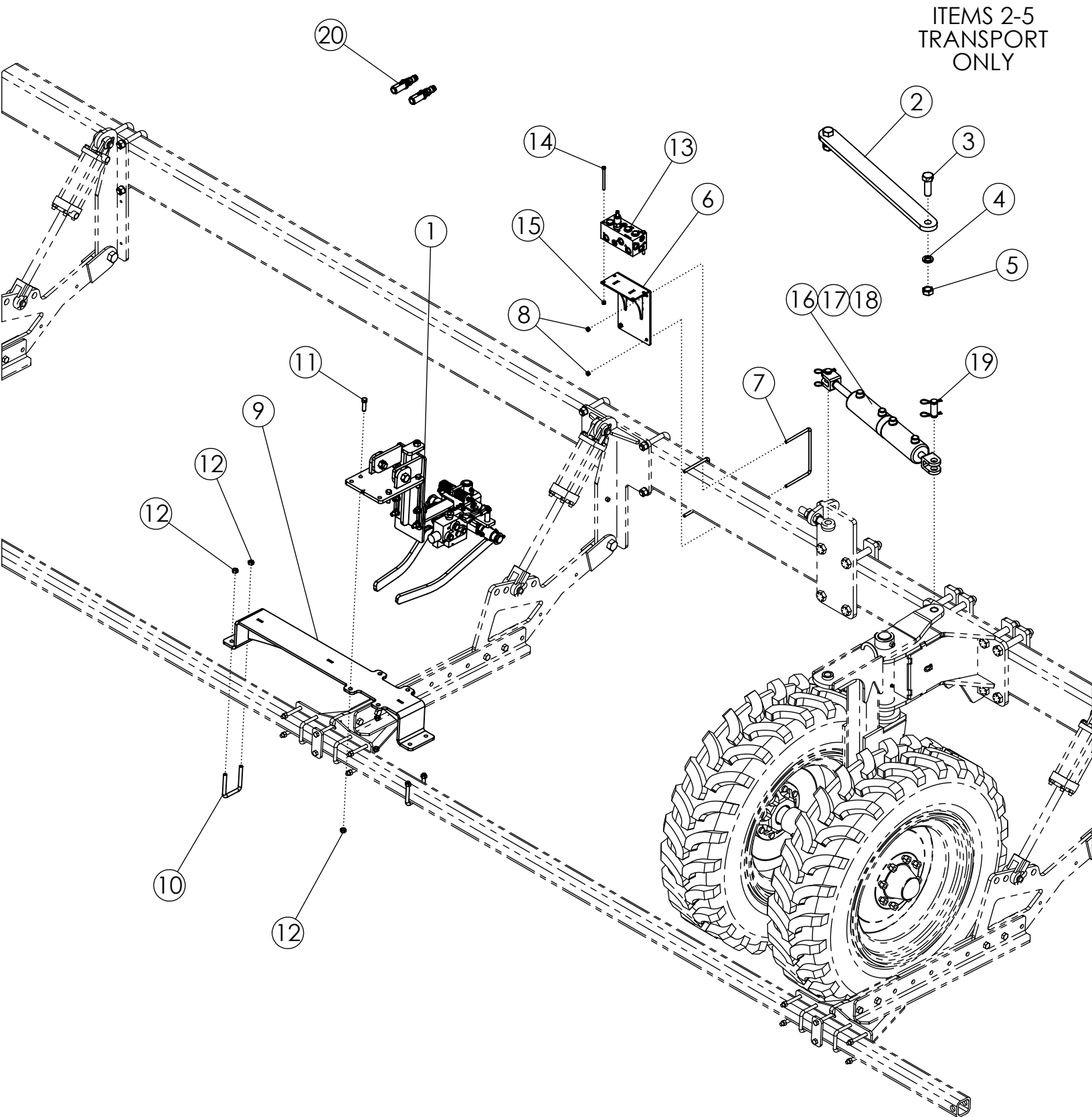

ROWFINDER SCALPER MOUNT (306005/307539)

ITEM	PART NO.	DESCRIPTION	QTY
1	306865	ASSY-ROW FINDER DEF (LESS CYL & HOSES)	1
2	306284	BAR-DEF STEERABLE TRANSPORT	1
3	1018007	BOLT-HEX: 1.0 X 3.00 NC GR5 ZP	2
4	1013539	WASHER-LOCK: 1.00 ZP	2
5	1012664	NUT-HEX: 1.00 NC GR2 ZP	2
6	69996	WLDMT-DEF RF VALVE MNT	1
7	64244	U-BOLT: .375 X 5.125 X 8.063 X 5.125	2
8	1016999	NUT-TOPLOCK: .38 NC GR5 ZP	4
9	69972	WLDMT-DEF RF MOUNT (2 ROW)	1
10	69954	U-BOLT: .500 X 4.00 X 3 X 4.00	2
11	1011608	BOLT-HEX: .50 X 1.75 NC GR5 ZP	4
12	1027461	NUT-TOPLOCK: .50 NC GR5 ZP	8
13	69999	VALVE-DEF RF RETURN	1
14	1030778	BOLT-HEX .313 X 4.00 NC GR5 ZP	2
15	1030700	NUT-TOPLOCK: .31 NC GR5 ZP	2
16	69200	CYLINDER-HYD 3X4 4PORT 24.5 CLOSED	1
17	305293	KT-CYLINDER SEALS (62344/69200) (RAM INDUS)	
18	307800	KT-CYLINDER SEALS (62344/69200) (CTD)	
19	69167	PIN-CYLINDER W/CLIPS 1.00 X 2.25	2
20	304187	ASSY-TRACTOR HYD COUPLERS (BLUE)	1

ROWFINDER FRAME MOUNT (306006/307540)

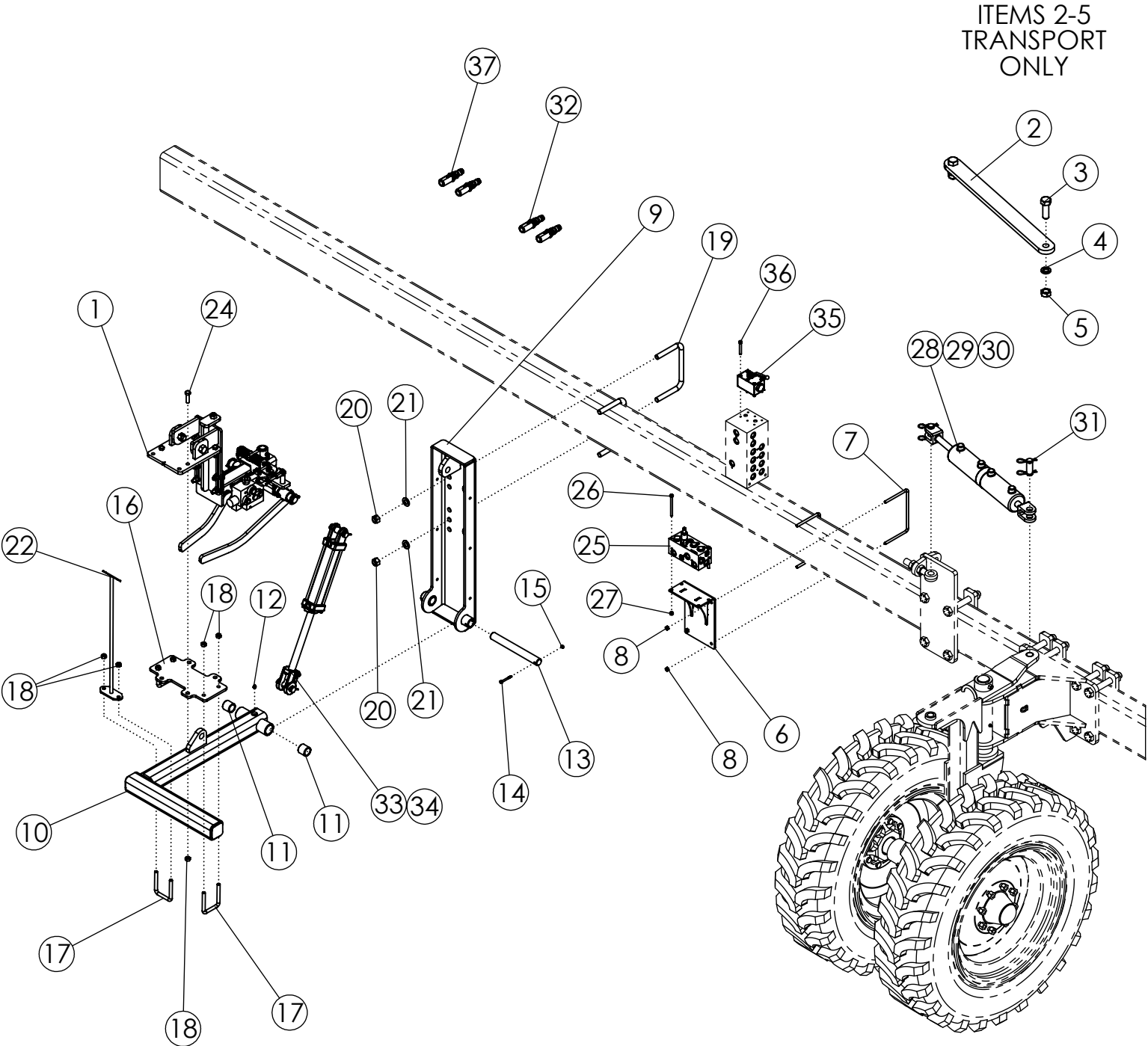

ROWFINDER FRAME MOUNT (306006/307540)

ITEM	PART NO.	DESCRIPTION	QTY
1	306865	ASSY-ROW FINDER DEF (LESS CYL & HOSES)	1
2	306284	BAR-DEF STEERABLE TRANSPORT	1
3	1018007	BOLT-HEX: 1.0 X 3.00 NC GR5 ZP	2
4	1013539	WASHER-LOCK: 1.00 ZP	2
5	1012664	NUT-HEX: 1.00 NC GR2 ZP	2
6	69996	WLDMT-DEF RF VALVE MNT	1
7	64244	U-BOLT: .375 X 5.125 X 8.063 X 5.125	2
8	1016999	NUT-TOPLOCK: .38 NC GR5 ZP	4
9	305057	WLDMT-ROW FINDER MOUNT UPPER	1
10	305058-1	WLDMT-ROW FINDER LOWER	1
11	56939	BUSHING-OILITE: 1.25 X 1.625 X 1.50L	2
12	1011748	ZERK-GREASE .25 UNF STRAIGHT	1
13	305053	SHAFT-ROW FINDER	1
14	1013942	BOLT-HEX: .25 X 2.25 NC GR5	1
15	1030946	NUT-TOPLOCK: .25 NC GR5 ZP	1
16	305056	PLATE-DEF FR MOUNT (1 ROW)	1
17	69954	U-BOLT: .500 X 4.00 X 3 X 4.00	3
18	1027461	NUT-TOPLOCK: .50 NC GR5 ZP	10
19	56263	U-BOLT: .75 X 5.5 X 8 X 5.5	2
20	1017000	NUT-TOPLOCK: .75 NC GR5 ZP	4
21	1012634	WASHER-FLAT: SAE .75 ZP	4
22	305410	WLDMT-INDICATOR RF FRAME MOUNT	1
23	65332	DECAL-RED ORANGE FLUORESCENT (NOT SHOWN)	1
24	1011608	BOLT-HEX: .50 X 1.75 NC GR5 ZP	4
25	69999	VALVE-DEF RF RETURN	1
26	1030778	BOLT-HEX .313 X 4.00 NC GR5 ZP	2
27	1030700	NUT-TOPLOCK: .31 NC GR5 ZP	2
28	69200	CYLINDER-HYD 3X4 4PORT 24.5 CLOSED	1
29	305923	KT-CYLINDER SEALS (62344/69200) (RAM INDUS)	
30	307800	KT-CYLINDER SEALS (62344/69200) (CTD)	
31	69167	PIN-CYLINDER W/CLIPS 1.00 X 2.25	2
32	304187	ASSY-TRACTOR HYD COUPLERS (BLUE)	1
33	321936	CYLINDER 2 X 8	1
34	321943	2NI SEAL KT (PRINCE)	
35	306028	VALVE-BALL MANIFOLD MOUNT	1
36	306097	BOLT-SHCS .31 X 2.25 NC ZP	6
37	304188	ASSY-TRACTOR HYD COUPLERS (GREEN)	1

REAR LIFT RATCHET JACK (307635)

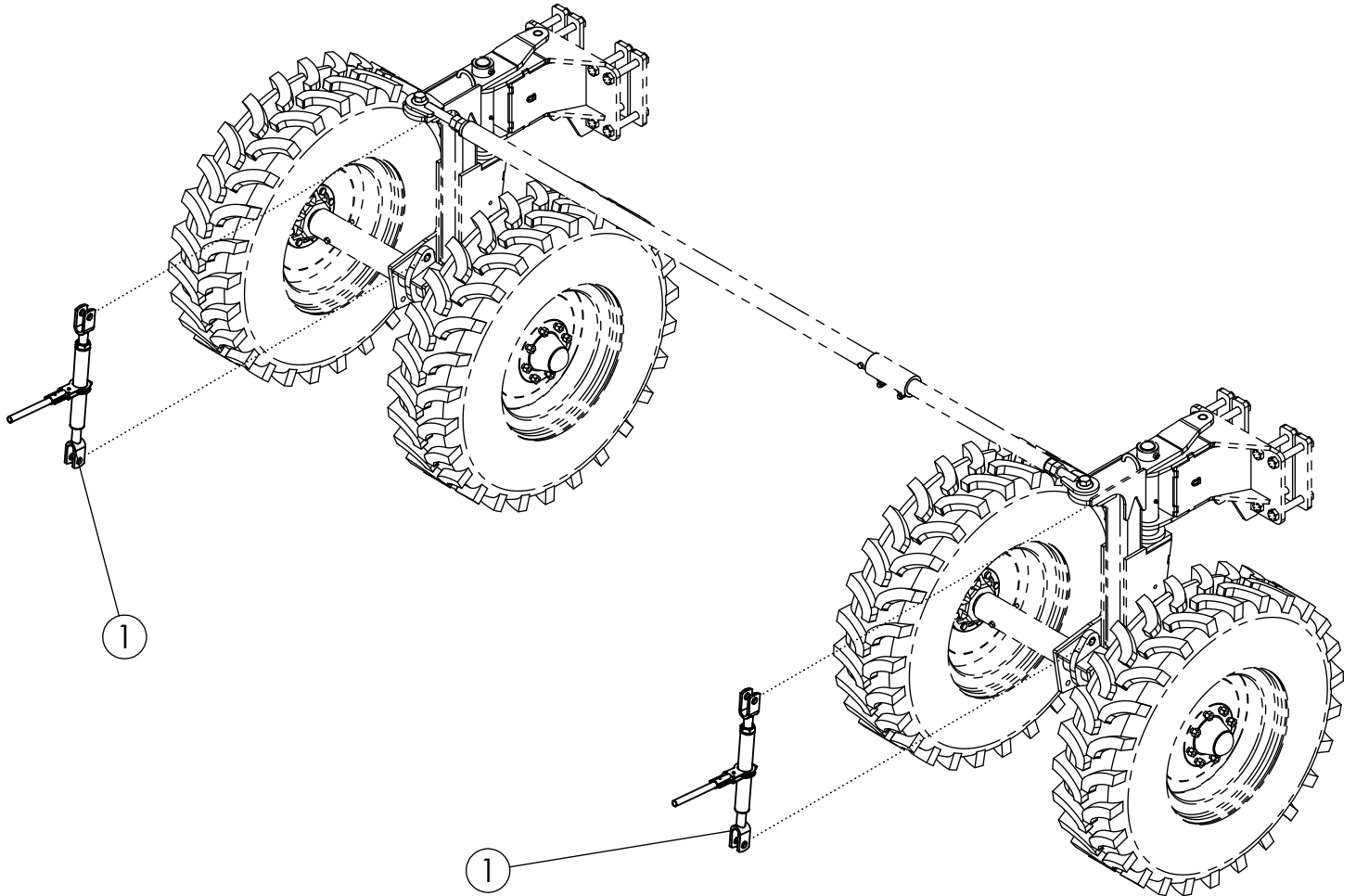

REAR LIFT RATCHET JACK (307635)

ITEM	PART NO.	DESCRIPTION	QTY
1	52407	RATCHET JACK PAINTED BLACK	2

REAR STRUT HYDRAULICS (306011)

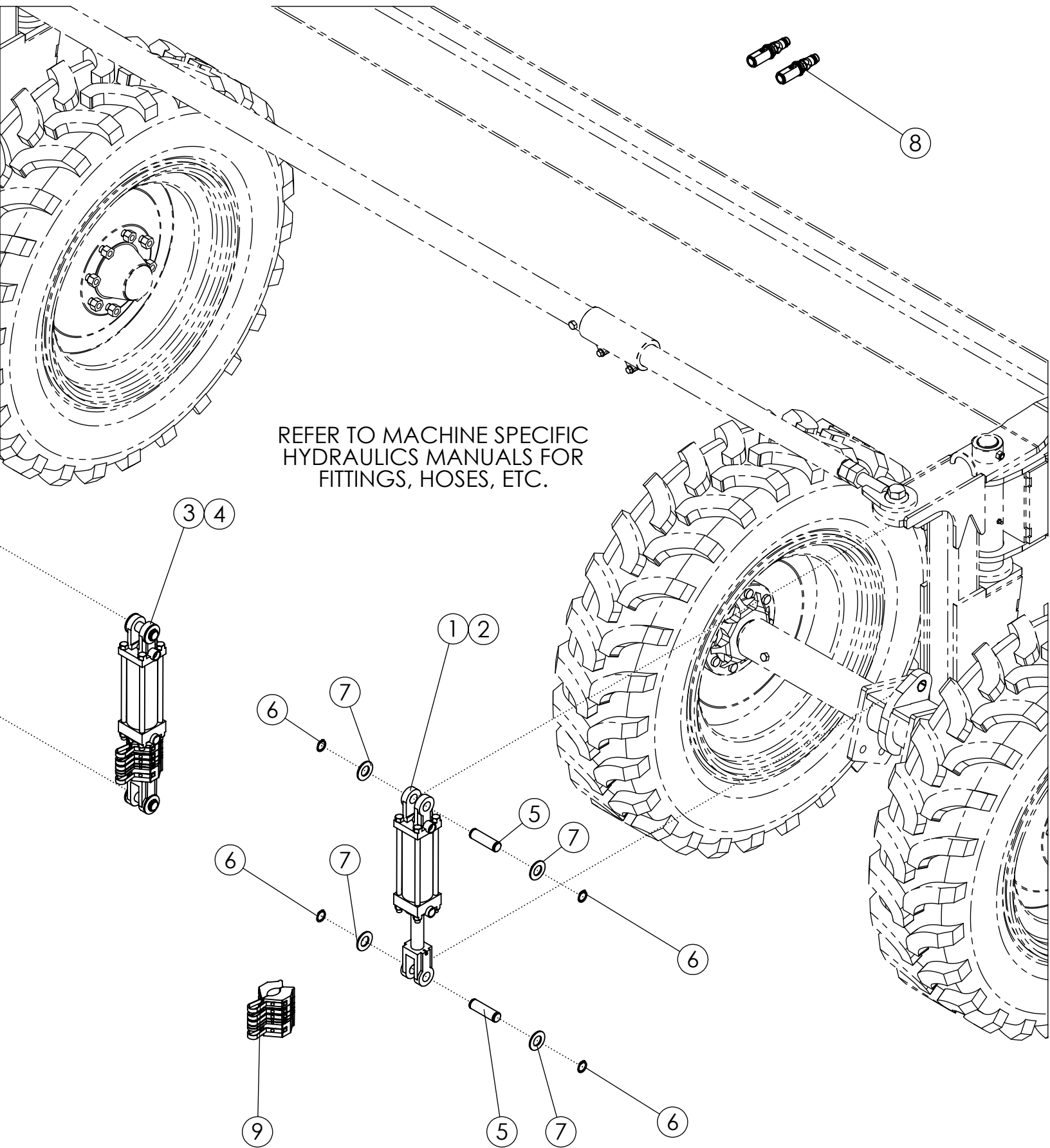

REAR STRUT HYDRAULICS (306011)

ITEM	PART NO.	DESCRIPTION	QTY
1	63499	CYLINDER-REPHASING 3.00 X 8.00	1
2	301314	SEAL KT-CYL 3 X 8 3000PSI	
3	63500	CYLINDER-REPHASING 3.25 X 8.00	1
4	66083	SEAL KT-CYL.: 3.25 X 8.0 IN #1026895	
5	311191	PIN-CYLINDER 1.00 X 3.03" W/ GROOVE ZP	4
6	36430	RING-RETAINING 1.000 ZP	8
7	1016663	WASHER-FLAT: SAE 1.00 ZP	8
8	304190	ASSY-TRACTOR HYD COUPLERS (SILVER)	1
9	51497	KT-CYLINDER STOP	2

AHC FRAME MOUNT (307248)

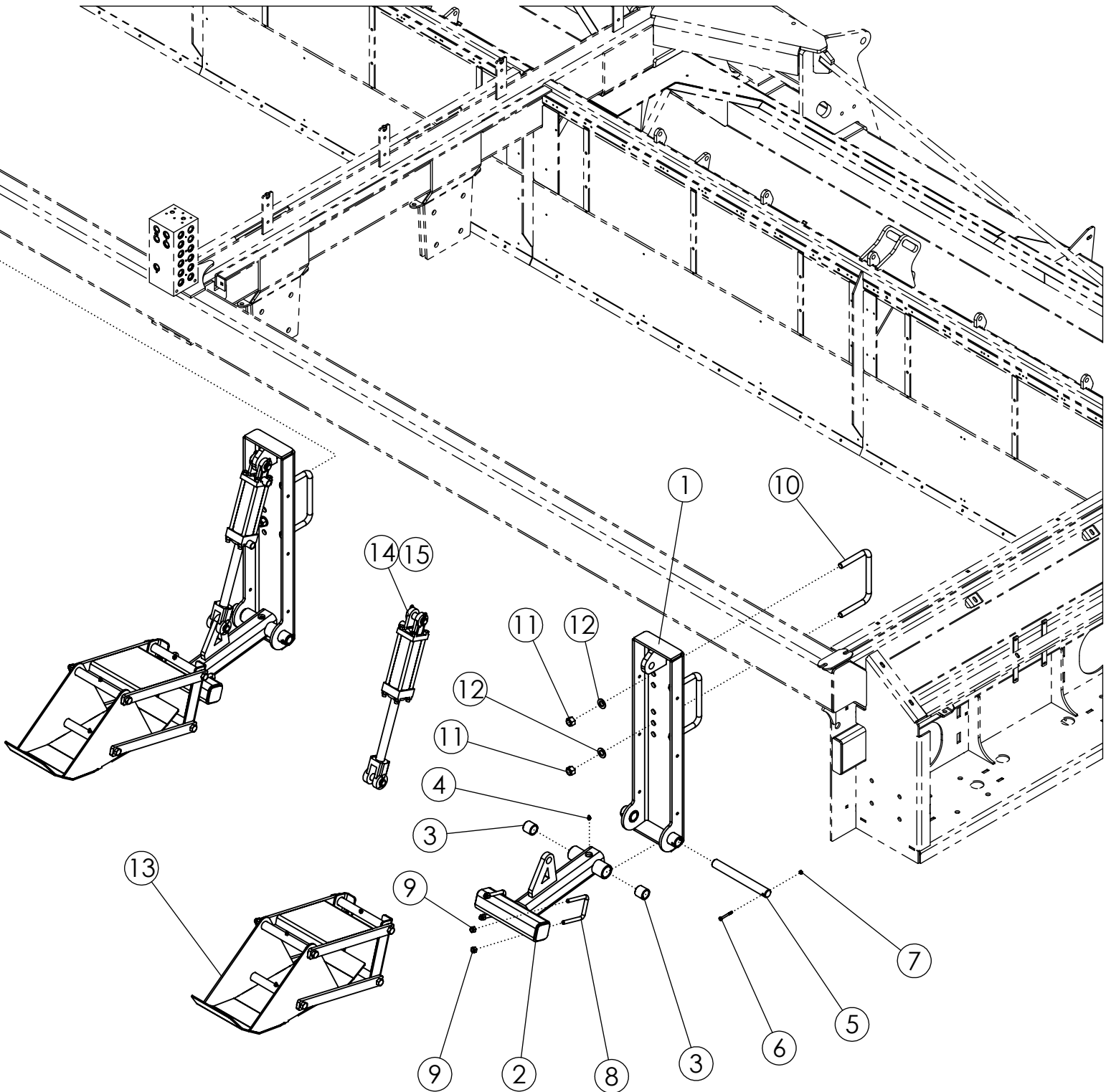

AHC FRAME MOUNT (307248)

ITEM	PART NO.	DESCRIPTION	QTY
1	305057	WLDMT-ROW FINDER MOUNT UPPER	2
2	305587	WLDMT- AHC MOUNT	2
3	56939	BUSHING-OILITE: 1.25 X 1.625 X 1.50L	4
4	1011748	ZERK-GREASE .25 UNF STRAIGHT	2
5	305053	SHAFT-ROW FINDER	2
6	1013942	BOLT-HEX: .25 X 2.25 NC GR5	2
7	1030946	NUT-TOPLOCK: .25 NC GR5 ZP	2
8	69954	U-BOLT: .500 X 4.00 X 3 X 4.00	4
9	1027461	NUT-TOPLOCK: .50 NC GR5 ZP	8
10	56263	U-BOLT: .75 X 5.5 X 8 X 5.5	4
11	1017000	NUT-TOPLOCK: .75 NC GR5 ZP	8
12	1012634	WASHER-FLAT: SAE .75 ZP	8
13	306887	ASSY-AHC SKID	2
14	58890	CYLINDER-HYDRAULIC 3 X 8" 3000	2
15	301314	SEAL KT-CYL 3 X 8 3000PSI	

AHC SKID ASSEMBLY (306887)

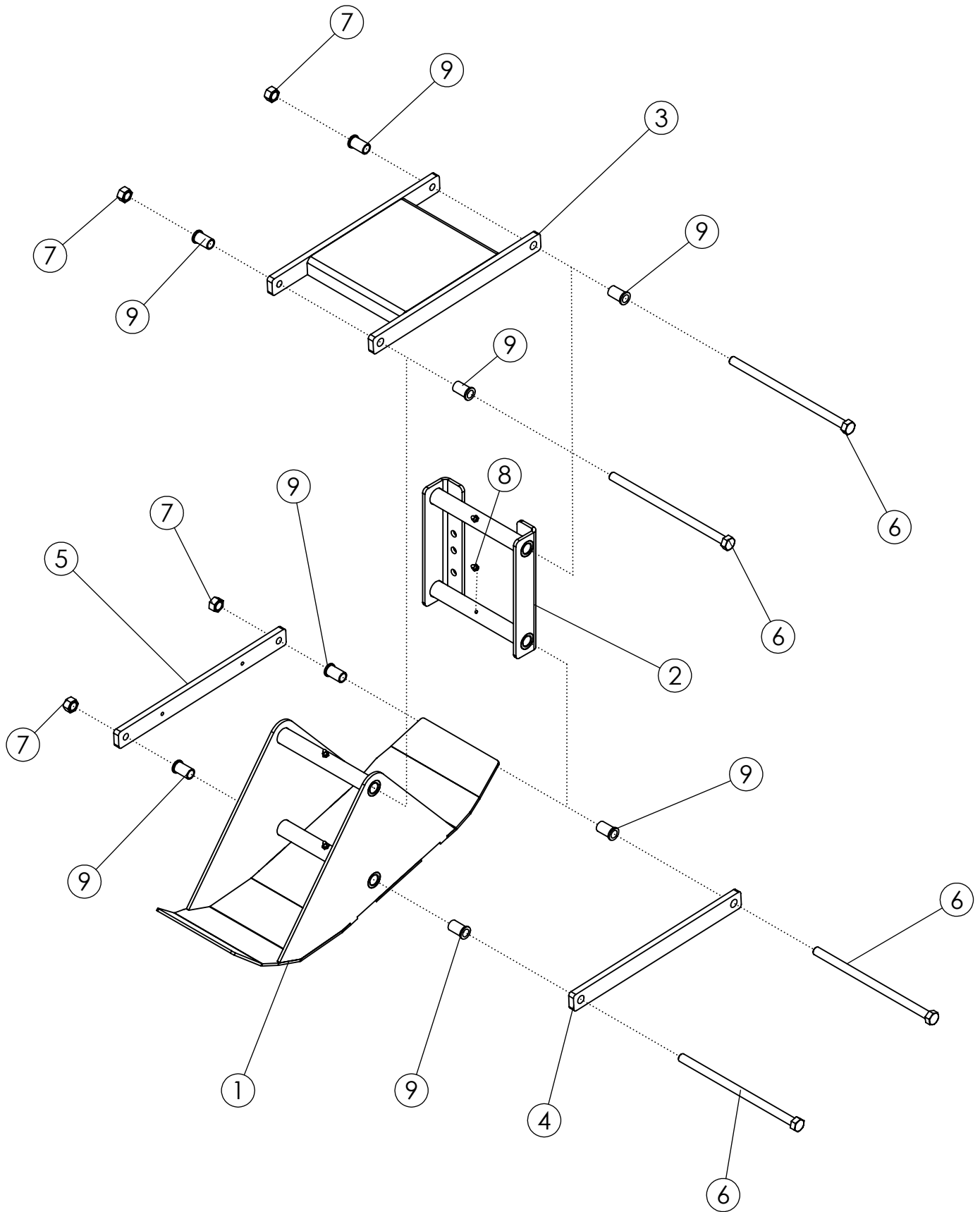

AHC SKID ASSEMBLY (306887)

ITEM	PART NO.	DESCRIPTION	QTY
1	305593	WLDMT- AHC SKID	1
2	63551	WLDMT-BASKET MOUNT	1
3	306849	WLDMT-UPPER PARALLEL LINK AHC	1
4	63555	BAR-PARALLEL LINK PAINTED	1
5	306848	BAR-PARALLEL LINK AHC THREADED PC	1
6	306752	BOLT-HEX: .63 X 11.94 NC GR5 ZP	4
7	59316	NUT-CENTERLOCK: .625 NC GR5 ZP	4
8	1011748	ZERK-GREASE .25 UNF STRAIGHT	4
9	306080	BUSHING-FLANGE: .628 X .816 X 1.4375L	8

AHC BASE COMPONENTS (307380)

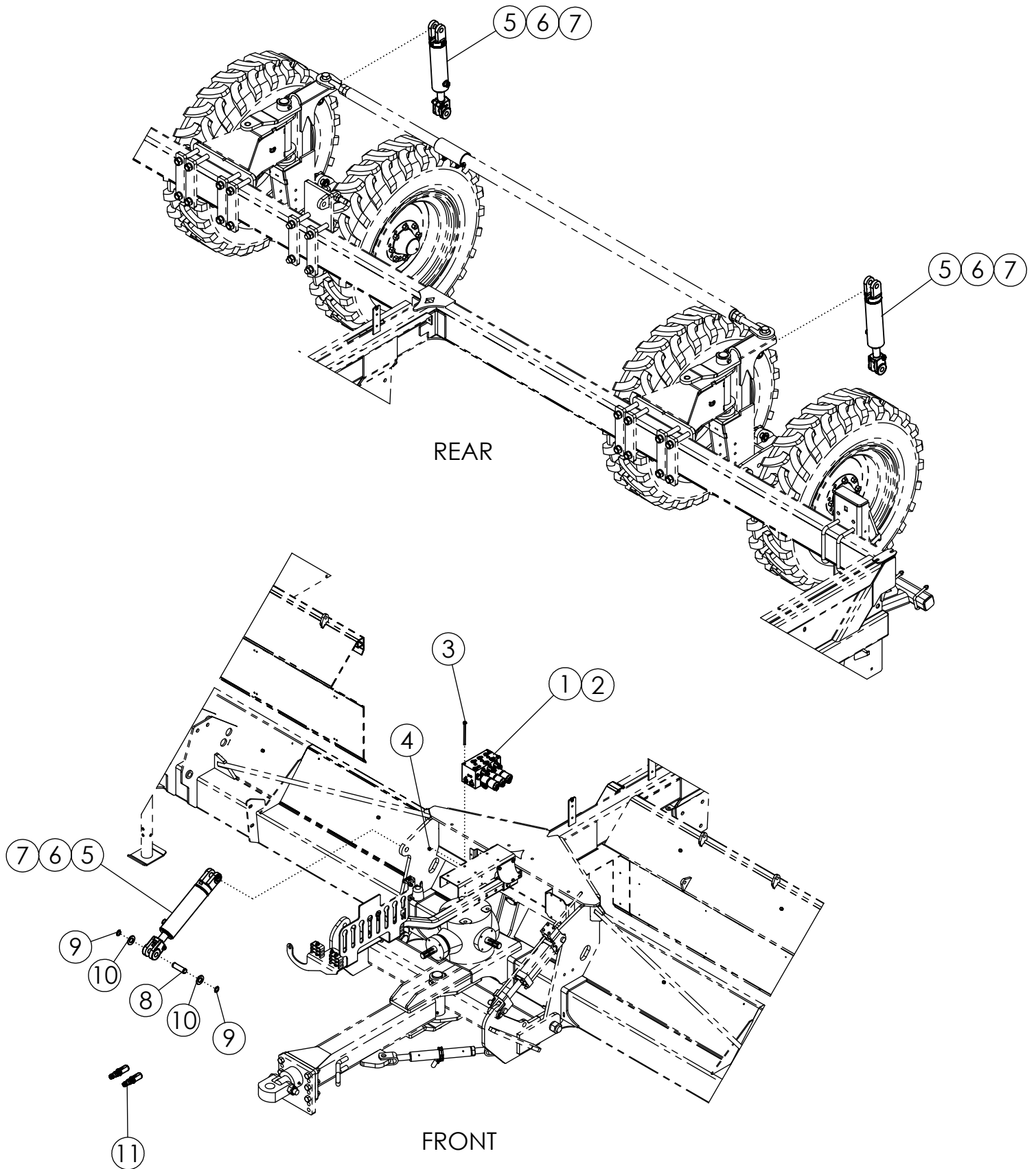

AHC BASE COMPONENTS (307380)

ITEM	PART NO.	DESCRIPTION	QTY
1	305939	VALVE-3 BANK AHC	1
2	306996	KT-SEAL FOR 305939	
3	306893	BOLT-HEX: .31 X 5.50 NC GR5 ZP	2
4	1030700	NUT-TOPLOCK: .31 NC GR5 ZP	2
5	307298	CYLINDER-HYD 3 X 8-3000-0° AHC (REPLACEABLE SENSOR)	3
6	307302	KT-SEAL FOR 307298 CYL	
7	307299	SENSOR-ROTA INTERNAL LINEAR SENSOR	
8	311191	PIN-CYLINDER 1.00 X 3.03" W/ GROOVE ZP	6
9	36430	RING-RETAINING 1.000 ZP	12
10	1016663	WASHER-FLAT: SAE 1.00 ZP	12
11	304190	ASSY-TRACTOR HYD COUPLERS (SILVER)	1

AHC ISOBUS CONTROLLER (307250)

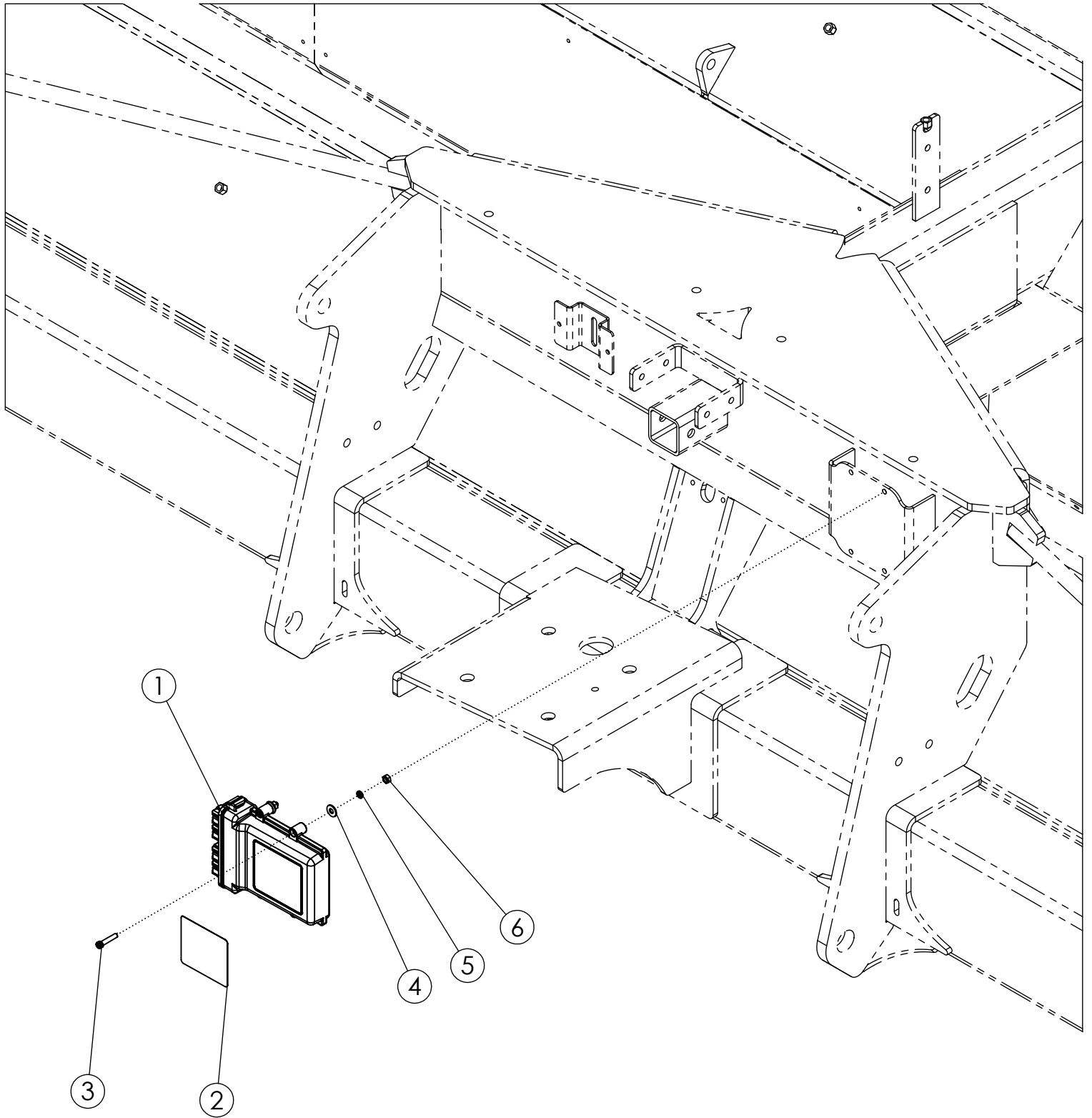

AHC ISOBUS CONTROLLER (307250)

ITEM	PART NO.	DESCRIPTION	QTY
1	307251	CONTROLLER- JCA FALCON CONTROLLER (AHC)	1
2	307252	DECAL-AHC CONTROLLER	1
3	304214	BOLT-SHCS: .25 X 1.25 NC ZP	4
4	1020416	WASHER-FLAT: .25 ZP	4
5	1013242	WASHER-LOCK: .25 ZP	4
6	1011587	NUT-HEX: .25 NC GR5 ZP	4

AHC/ADC JOYSTICK W/ MOUNT (303447)

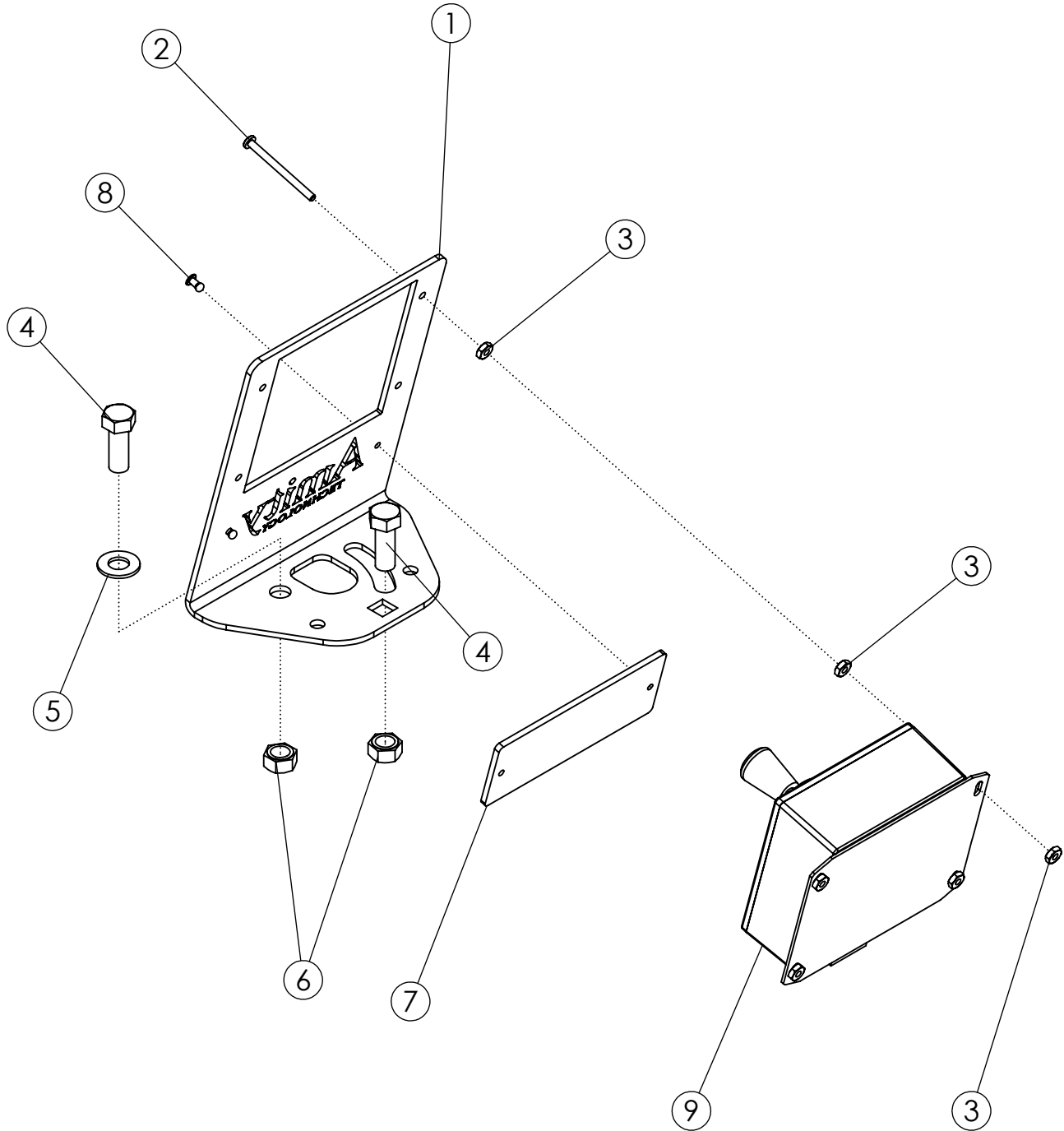

AHC/ADC JOYSTICK W/ MOUNT (303447)

ITEM	PART NO.	DESCRIPTION	QTY
1	303451	PLATE-JOYSTICK MOUNT	1
2	1019992	SCREW P-H: #6 X 1.75 NC GR5 ZP	4
3	1040448	#6 NUT	12
4	1011600	BOLT-HEX: .38 X 1.00 NC GR5 ZP	2
5	1014608	WASHER-FLAT: SAE .38 ZP	1
6	1016999	NUT-TOPLOCK: .38 NC GR5 ZP	2
7	311514	PLATE-JOYSTICK LOGO	1
8	59882	RIVET-POP: .13 X .31 ZP	2
9	301151	ASSY-JOYSTICK & ENCLOSURE	1
10	303444	HARNESS-ADC/AHC ISOBUS JOYSTICK EXT (NOT SHOWN)	1

AHC SENSOR ASSEMBLY (307567)

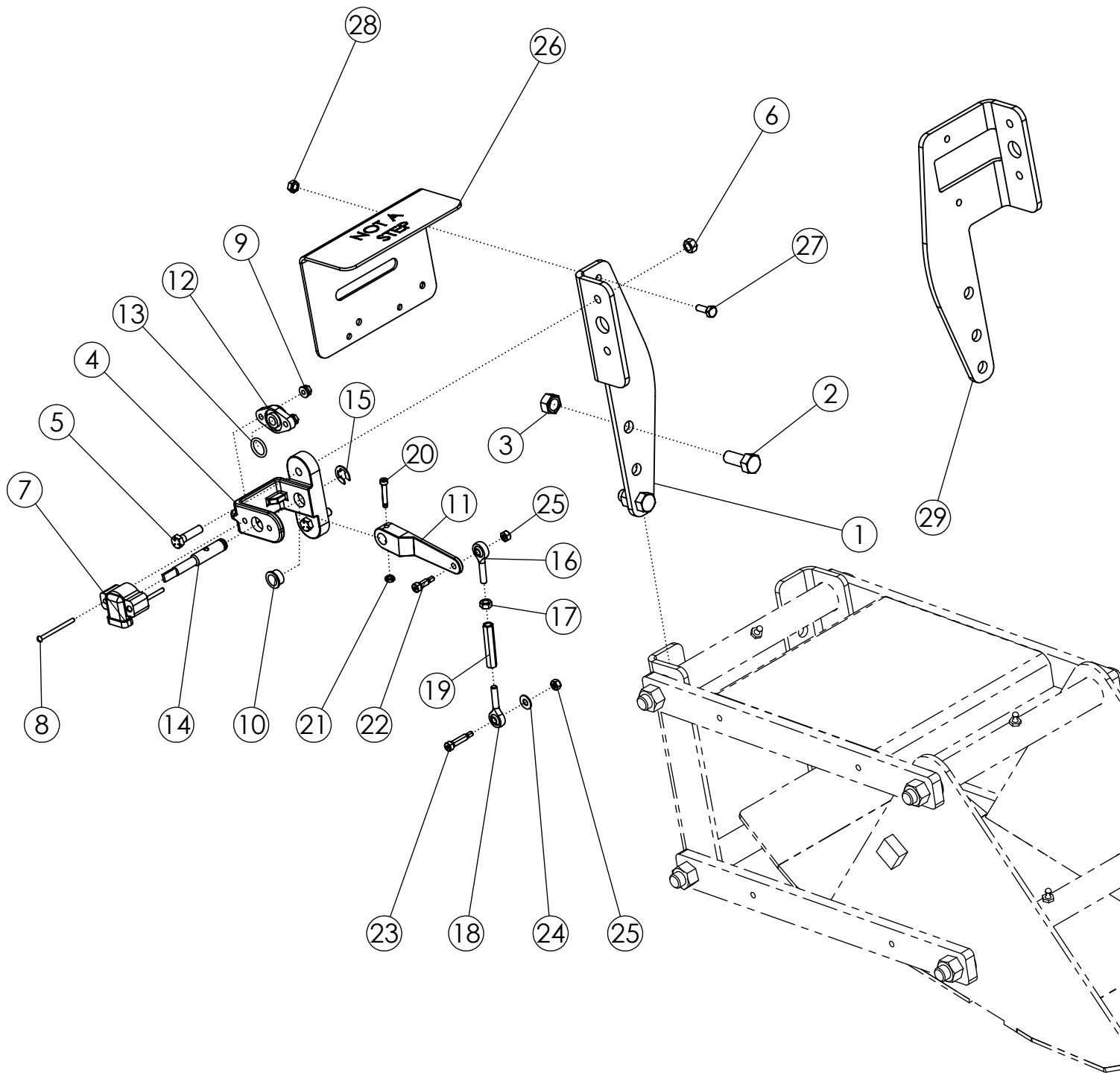

AHC SENSOR ASSEMBLY (307567)

ITEM	PART NO.	DESCRIPTION	QTY
1	306835	PLATE-AHC SENSOR MOUNT BRACKET LH	1
2	1011606	BOLT-HEX: .50 X 1.25 NC GR5 ZP	4
3	1027461	NUT-TOPLOCK: .50 NC GR5 ZP	4
4	306821	SENSOR BRACKET-AHC	2
5	1032277	BOLT-HEX: .31 X 1.25 NC GR5 ZP	4
6	1030700	NUT-TOPLOCK: .31 NC GR5 ZP	4
7	73492	SENSOR-ROTARY POSITION	2
8	306836	SCREW-MACH RND: #10-24 X 2.0" PHILLIPS	4
9	1026591	NUT-K-LOCK: #10-24 NC GR2 ZP	4
10	306822	GROMMET-AHC SHAFT	2
11	306823	LEVER-AHC	2
12	306825	SUPPORT-SHAFT AHC	2
13	306826	O-RING	2
14	306827	SHAFT-AHC ZP	2
15	306895	SNAP RING: FOR 1/2" OD- 0.46 ID X .035"	2
16	306828	BALL JOINT ROD END 1/4"-28 RH	2
17	1011579	NUT-HEX: .25 NF GR2 ZP	2
18	306829	BALL JOINT ROD END 1/4"-28 LH	2
19	306830	TURNBUCKLE 1/4"-28	2
20	306831	BOLT-SHOULDER: 3/16" X 1.0" SHLD LNGTH X #8-32 THRD	2
21	307497	NUT-LOCK: #8-32 GR2 ZP THIN	2
22	306832	BOLT-SHOULDER: 1/4" X 1/2" SHLD LNGTH X #10-24 THRD	2
23	306833	BOLT-SHOULDER: 1/4" X 1.0" SHLD LNGTH X #10-24 THRD	2
24	65695	WASHER-FLAT: .25 SS	2
25	67079	NUT-NYLOCK: #10-24 NC GR2 ZP	4
26	306926	PLATE-AHC SENSOR COVER	2
27	1011595	BOLT-HEX: .25 X .75 NC GR5 ZP	4
28	1030946	NUT-TOPLOCK: .25 NC GR5 ZP	4
29	307686	PLATE-AHC SENSOR MOUNT BRACKET RH	1

AHC SENSOR KIT (306834)

PTO SENSOR MOUNT

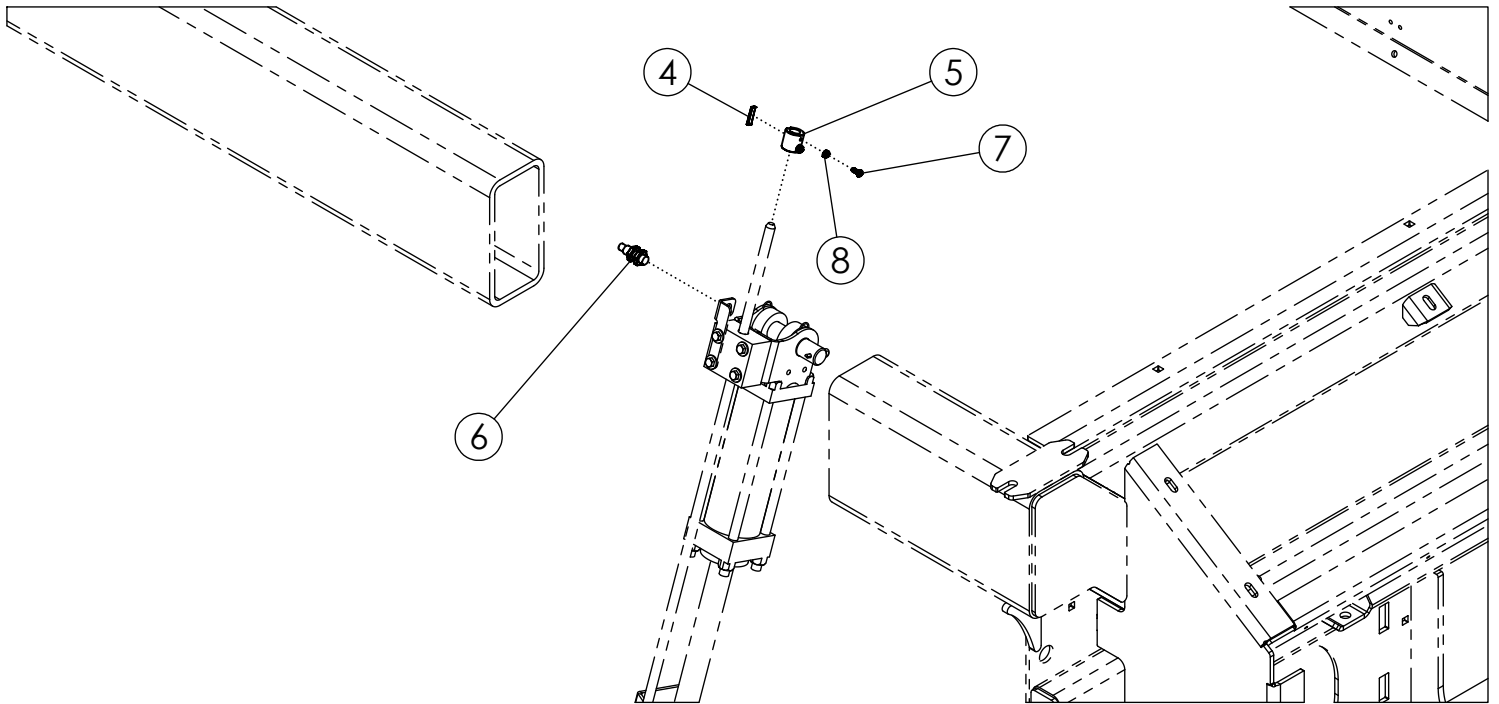

NOTE:
ASSEMBLE WORKSWITCH
TO DEPTH SENSOR ON CYL
THAT RAISES AHC BASKET;
EITHER SCALPER LIFT OR
AHC FRAME BASKET LIFT.
SENSOR SHOULD BE NEAR
TOUCHING THE MAGNET
IN THE LOWERED/DOWN
POSITION

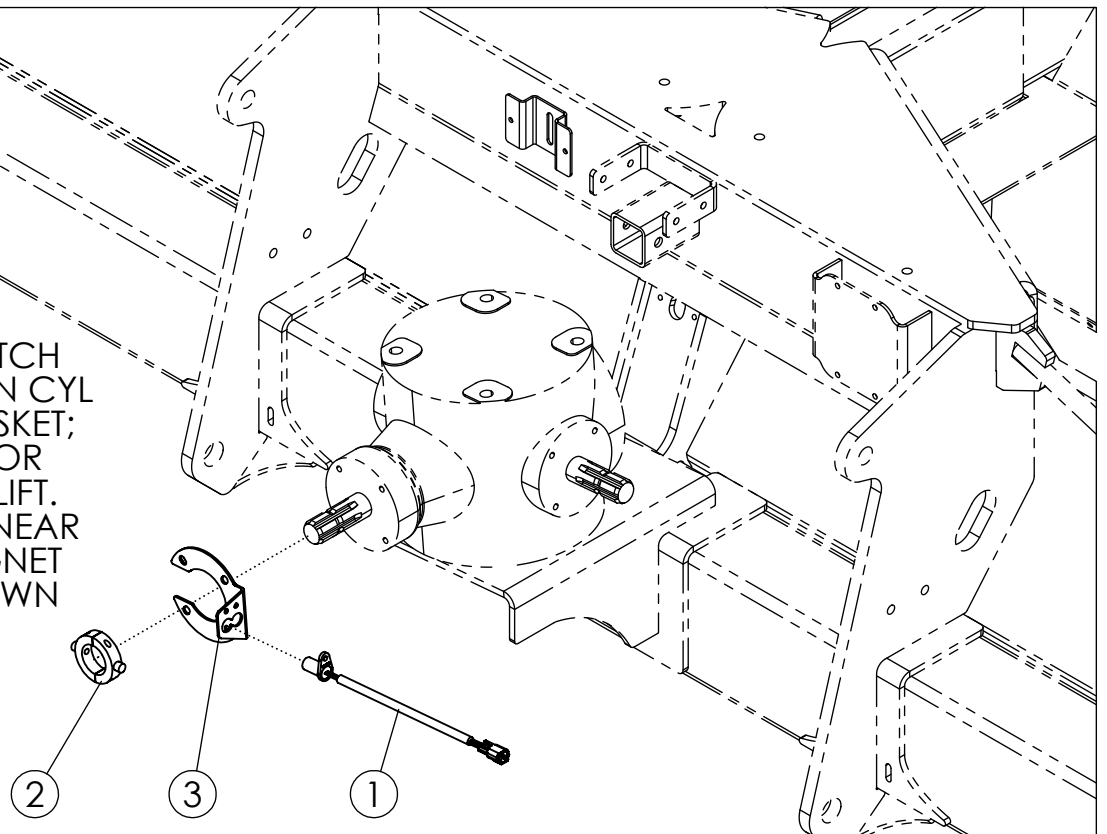

WORKSWITCH MOUNT

AHC SENSOR KIT (306834)

ITEM	PART NO.	DESCRIPTION	QTY
1	301014	SENSOR-PTO ADC	1
2	64388	WLDMT-SPLIT COLLAR 1.75"	1
3	305958	PLATE-PTO SENSOR MOUNT	1
4	305959	MAGNET-WORK SWITHC AHC	1
5	305595	TUBE-AHC MAGNET HOLDER ZP	1
6	306862	ASSY-MAGNETIC PROXIMITY SENSOR AHC	1
7	750354	SCREW-PHILLIP: #10-24 X .50	2
8	65348	NUT-HEX: SS #10-24	2

AHC DEPTH GAUGE (306976)

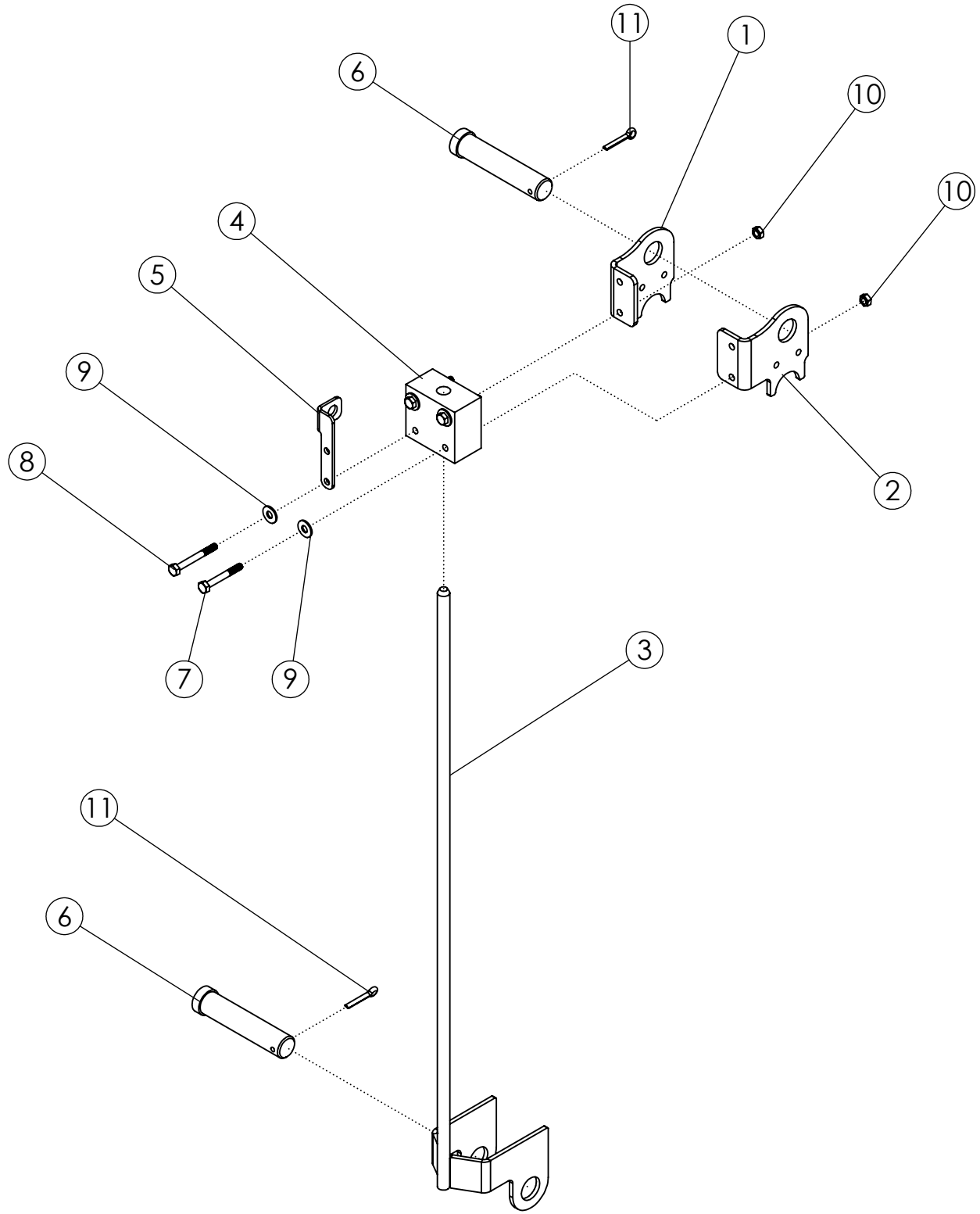

AHC DEPTH GAUGE (306976)

ITEM	PART NO.	DESCRIPTION	QTY
1	306962	PLATE-DEPTH GAUGE BRACKET RH	1
2	306963	PLATE-DEPTH GAUGE BRACKET LH	1
3	63999	WLDMT - BOTTOM BRACKET ZP	1
4	63383	POLY GUIDE BLOCK	1
5	306896	PLATE-MAGNETIC SENSOR MNT	1
6	63406	PIN-CLEVIS: 1.00 X 4.00 ZP	2
7	1016211	BOLT-HEX: .25 X 2.00 NC GR5	2
8	1013942	BOLT-HEX: .25 X 2.25 NC GR5	2
9	1020416	WASHER-FLAT: .25 ZP	4
10	1030946	NUT-TOPLOCK: .25 NC GR5 ZP	4
11	1012375	PIN-COTTER .19 X 1.50 ZP	2

AHC ELECTRICAL COMPONENTS

TOP VIEW

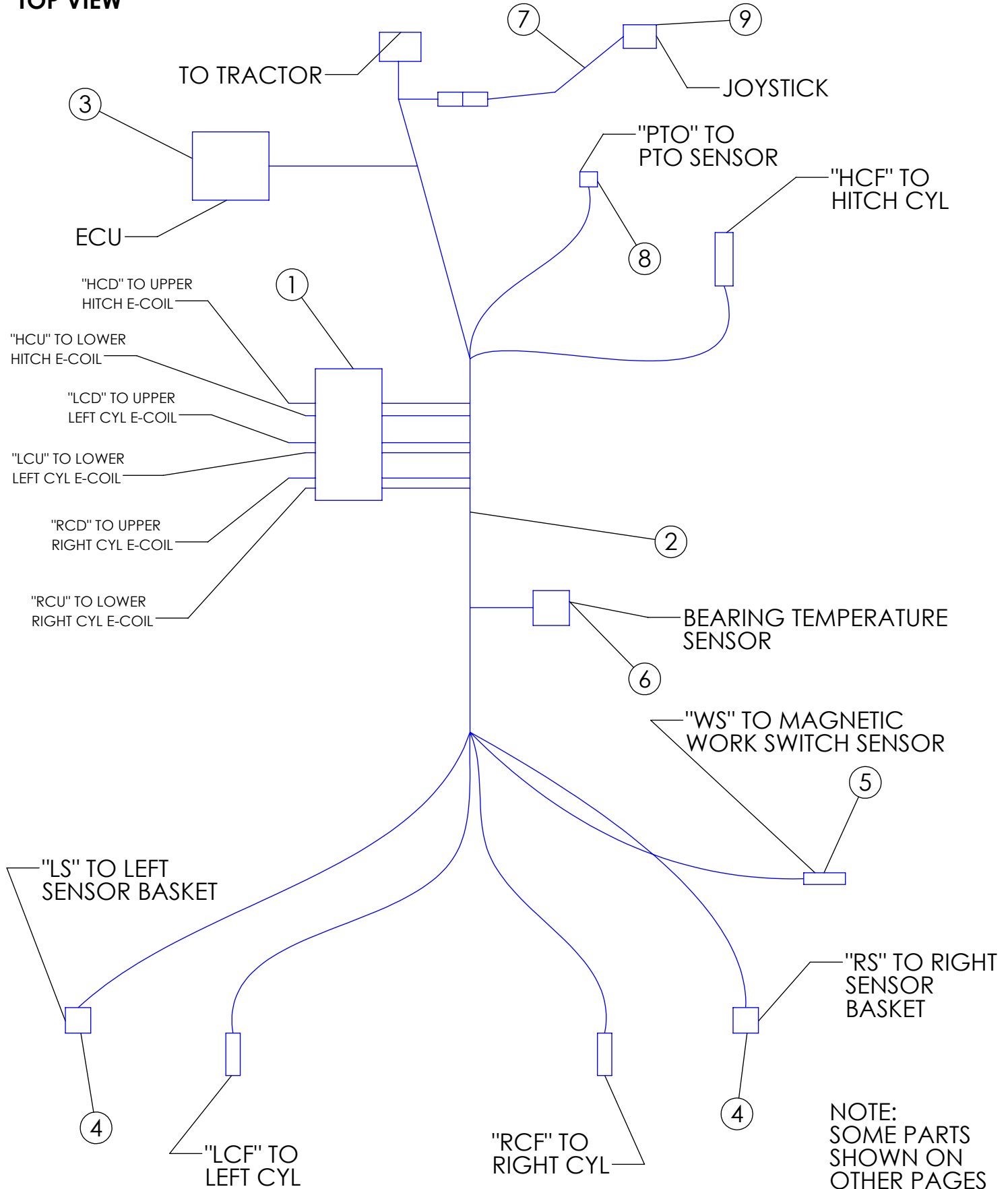

AHC ELECTRICAL COMPONENTS

ITEM	PART NO.	DESCRIPTION	QTY
1	305939	VALVE-3 BANK AHC	1
	306996	KT-SEAL FOR 305939	
2	307253	HARNESS-AHC ISOBUS MAIN	1
3	307250	ASSY-AHC ISOBUS CONTROLLER	1
4	73492	SENSOR-ROTARY POSITION	2
5	306862	ASSY-MAGNETIC PROXIMITY SENSOR AHC	1
6	307255	SENSOR-AHC TEMPERATURE SENSOR	1
7	303444	HARNESS-ADC/AHC ISOBUS JOYSTICK EXT	1
8	301014	SENSOR-PTO ADC	1
9	301151	ASSY-JOYSTICK ENCLOSURE	1

SCALPER BAR ASSEMBLY (306009/307545)

ITEMS 23 & 24 ONLY USED WITH
WIDE STANCE SCALPER KIT (305405)
TO REPLACE QTY(2) OF ITEM 1

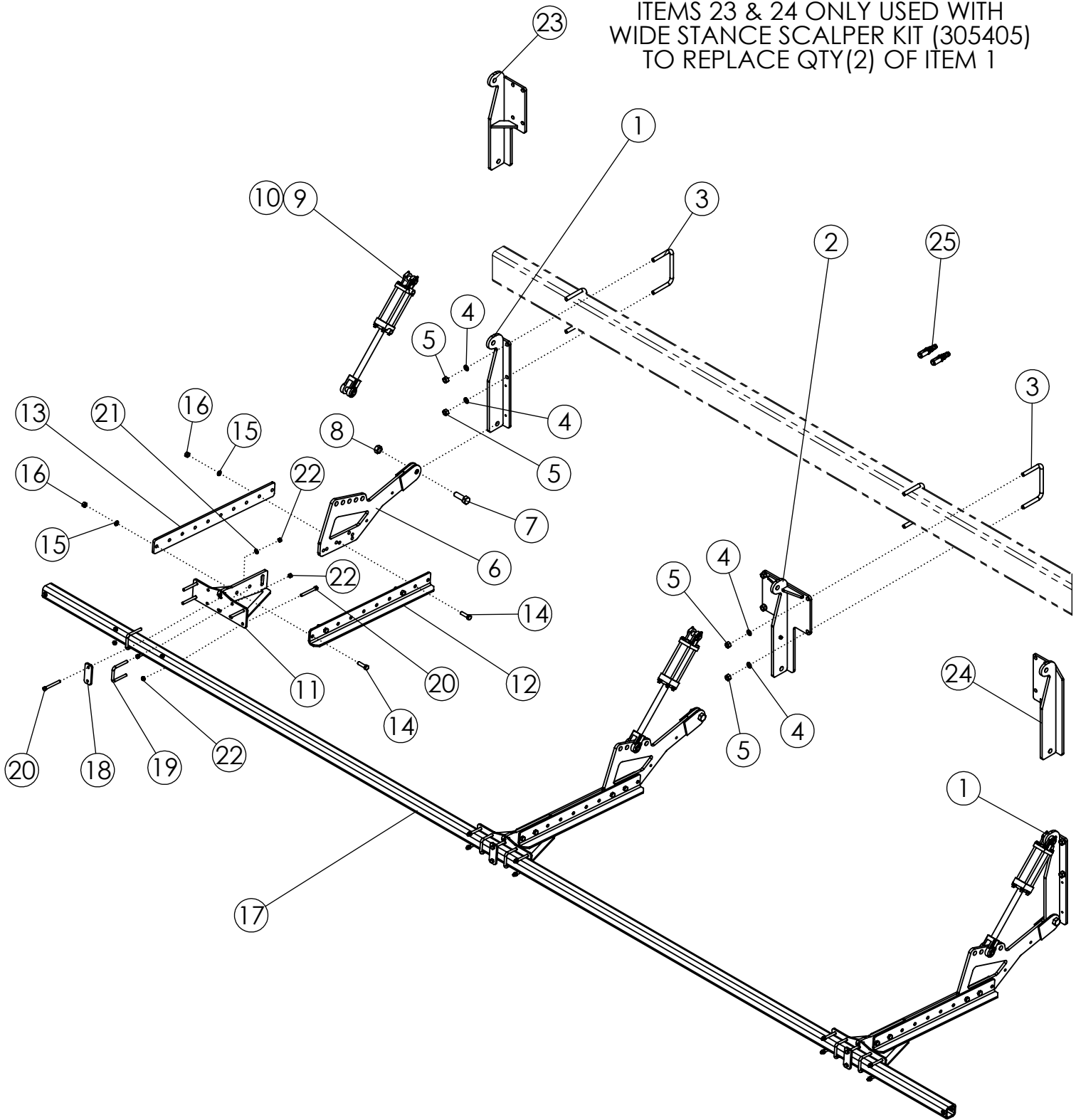

SCALPER BAR ASSEMBLY (306009/307545)

ITEM	PART NO.	DESCRIPTION	QTY
1	68239	WLDMT - MOUNT	2
2	69011	WLDMT-CENTER CYL MNT	1
3	56263	U-BOLT: .75 X 5.5 X 8 X 5.5	6
4	1012061	WASHER-LOCK: .75 ZP	12
5	1011620	NUT-HEX: .75 NC GR2 ZP	12
6	69126	WLDMT-SCALPER ARM MNT	3
7	1018007	BOLT-HEX: 1.0 X 3.00 NC GR5 ZP	3
8	1016969	NUT-TOPLOCK: 1.00 NC GR8 ZP	3
9	58890	CYLINDER-HYDRAULIC 3 X 8" 3000	3
10	301314	SEAL KT-CYL 3 X 8 3000PSI	
11	69127	WLDMT-BAR MNT BRACKET	3
12	305183	PLATE-SCALPER EXT	3
13	306101	PLATE-SCALPER EXT FLAT	3
14	1017526	BOLT-HEX .63 X 2.25 NC GR5 ZP	12
15	1011813	WASHER-LOCK: .63 ZP	12
16	1011578	NUT-HEX: .63 NC GR2 ZP	12
17	51863	BAR-SCALPER 12R-22	1
18	51551	BAR-BASKET MOUNTING	3
19	69954	U-BOLT: .500 X 4.00 X 3 X 4.00	6
20	1013682	BOLT-HEX: .50 X 4.50 NC GR5 ZP	18
21	1011584	WASHER-FLAT: SAE .50 ZP	6
22	1027461	NUT-TOPLOCK: .50 NC GR5 ZP	30
23	305406	WLDMT-MOUNT EXTENDED LH	1
24	305407	WLDMT-MOUNT EXTENDED RH	1
25	304188	ASSY-TRACTOR HYD COUPLERS (GREEN)	1

SCALPER BASKET LONG W/ HARDWARE (51475)

SCALPER BASKET LONG W/O HARDWARE
(PN 63462) ONLY INCLUDES ITEMS 1-9

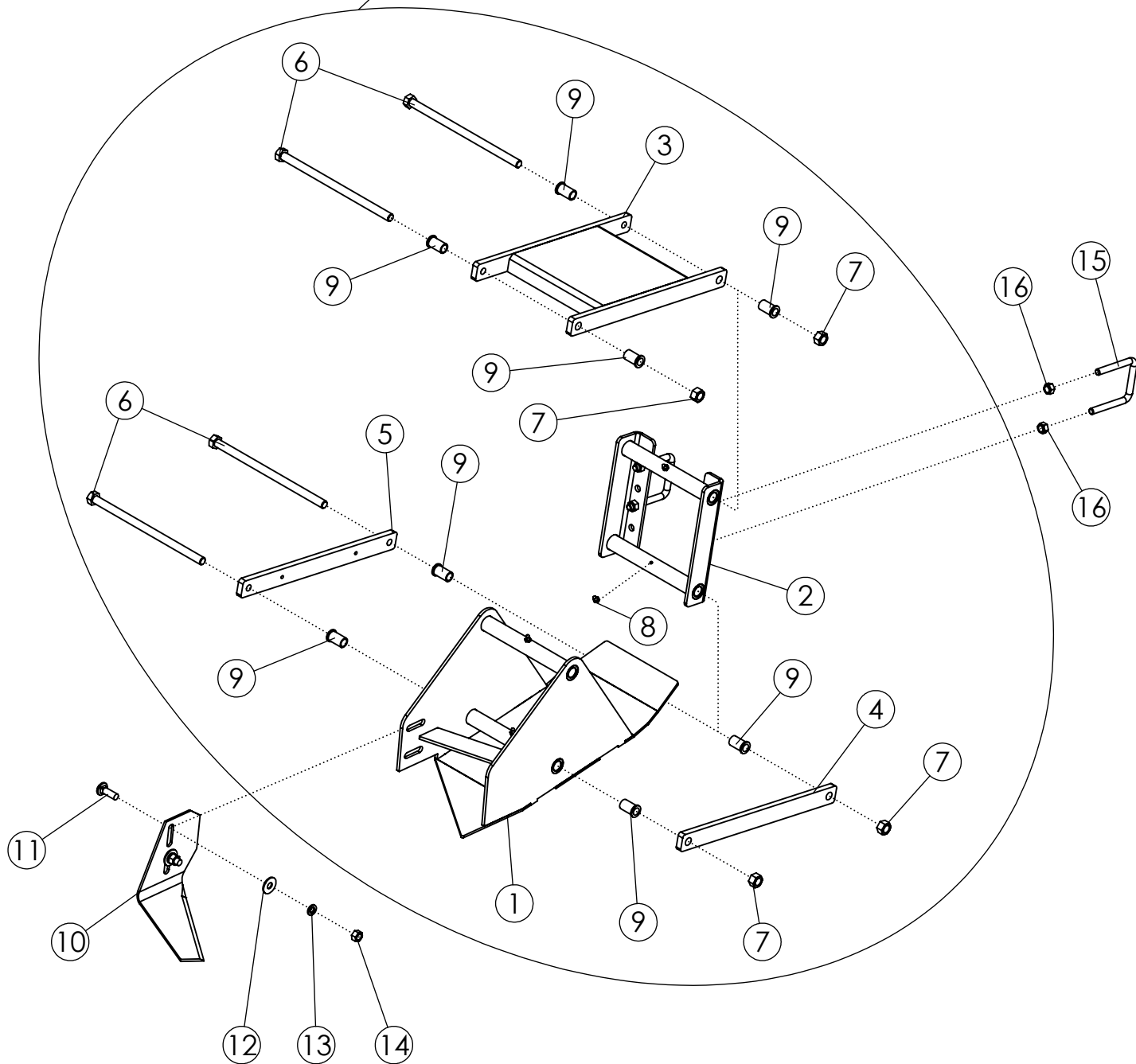

SCALPER BASKET LONG W/ HARDWARE (51475)

ITEM	PART NO.	DESCRIPTION	QTY
1	63550	WLDMT-BASKET FRAME	1
2	63551	WLDMT-BASKET MOUNT	1
3	306849	WLDMT-UPPER PARALLEL LINK AHC	1
4	63555	BAR-PARALLEL LINK PAINTED	1
5	306848	BAR-PARALLEL LINK AHC THREADED PC	1
6	306752	BOLT-HEX: .63 X 11.94 NC GR5 ZP	4
7	59316	NUT-CENTERLOCK: .625 NC GR5 ZP	4
8	1011748	ZERK-GREASE .25 UNF STRAIGHT	4
9	306080	BUSHING-FLANGE: .628 X .816 X 1.4375L	8
10	51782	SCALPER KNIFE-HEAT TREAT	1
11	1011660	BOLT-CRG: .50 X 1.50 NC GR5 ZP	2
12	1014443	WASHER-FLAT: .50 ZP	2
13	1011581	WASHER-LOCK: .50 ZP	2
14	1011577	NUT-HEX: .50 NC GR2 ZP	2
15	69954	U-BOLT: .500 X 4.00 X 3 X 4.00	2
16	1027461	NUT-TOPLOCK: .50 NC GR5 ZP	4

SCALPER BASKET SHORT W/ HARDWARE (307160)

SCALPER BASKET SHORT W/O HARDWARE
(PN 307161) ONLY INCLUDES ITEMS 1-9

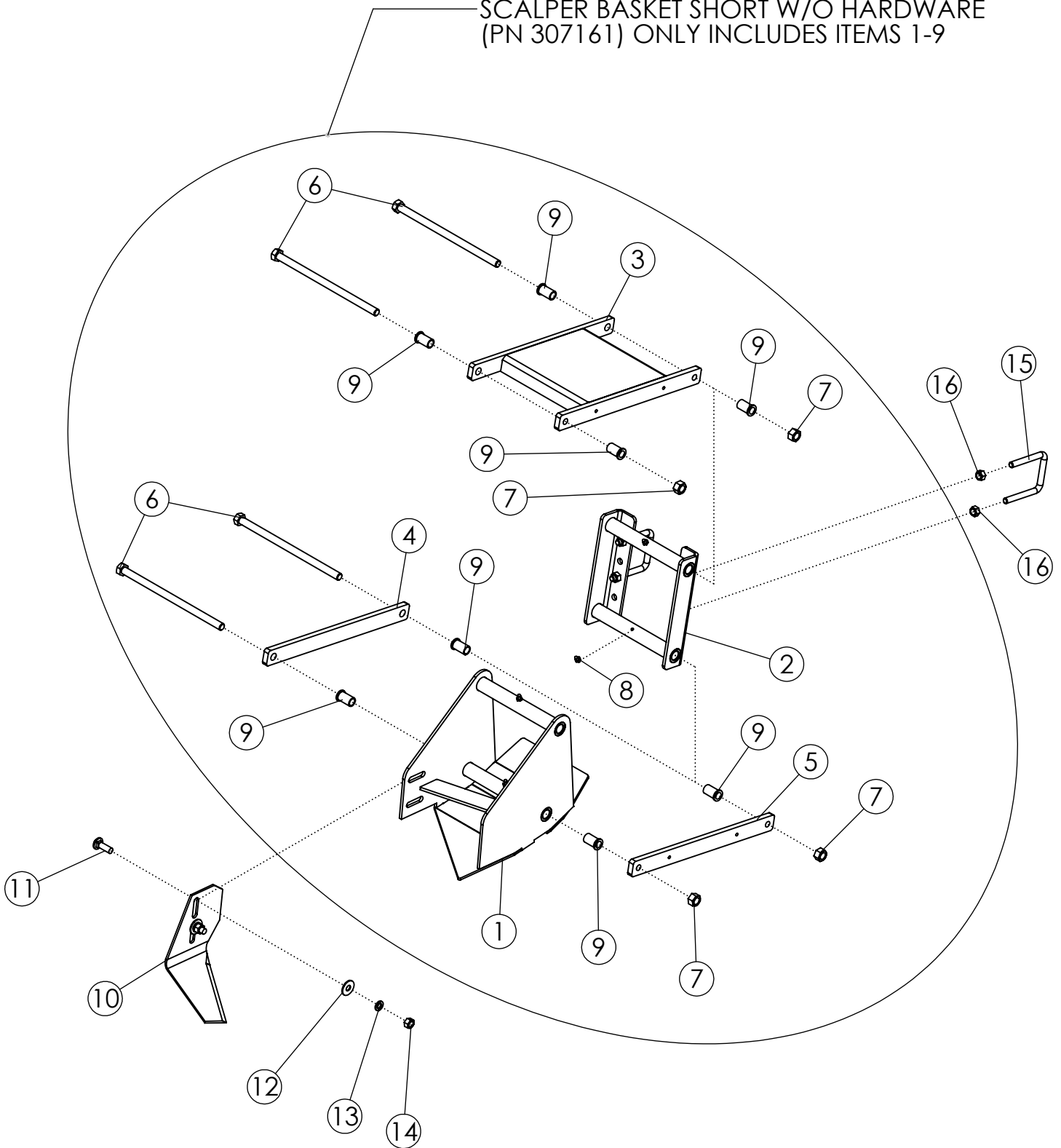

SCALPER BASKET SHORT W/ HARDWARE (307160)

ITEM	PART NO.	DESCRIPTION	QTY
1	306948	WLDMT-BASKET FRAME V2	1
2	63551	WLDMT-BASKET MOUNT	1
3	306849	WLDMT-UPPER PARALLEL LINK AHC	1
4	63555	BAR-PARALLEL LINK PAINTED	1
5	306848	BAR-PARALLEL LINK AHC THREADED PC	1
6	306752	BOLT-HEX: .63 X 11.94 NC GR5 ZP	4
7	59316	NUT-CENTERLOCK: .625 NC GR5 ZP	4
8	1011748	ZERK-GREASE .25 UNF STRAIGHT	4
9	306080	BUSHING-FLANGE: .628 X .816 X 1.4375L	8
10	51782	SCALPER KNIFE-HEAT TREAT	1
11	1011660	BOLT-CRG: .50 X 1.50 NC GR5 ZP	2
12	1014443	WASHER-FLAT: .50 ZP	2
13	1011581	WASHER-LOCK: .50 ZP	2
14	1011577	NUT-HEX: .50 NC GR2 ZP	2
15	69954	U-BOLT: .500 X 4.00 X 3 X 4.00	2
16	1027461	NUT-TOPLOCK: .50 NC GR5 ZP	4

STABILIZER WHEELS (305695/307546)

ITEM	PART NO.	DESCRIPTION	QTY
1	306055	WLDMT-STABILIZER STRUT '50	2
2	68915	TIRE-MNTD: 6.50-16 6 PLY I-1 TITAN DURALIFE	2
3	306061	HUB-STABILIZER 5000LB	2
4	306063	BEARING-CUP	4
5	306062	BEARING-CONE 1.500 BORE	4
6	306059	SEAL-OIL CR	4
7	68931	BOLT-WHEEL LUG .562-18UNF X 1.75	12
8	1011748	ZERK-GREASE .25 UNF STRAIGHT	4
9	306048	WLDMT-STABILIZER SPINDLE ZP	2
10	306054	SPACER-SPINDLE ZP	4
11	306052	NUT-HEX: SLOT 1.500 NF GR2 ZP	2
12	306034	PIN-COTTER: .25 X 3.00 ZP	2
13	306051	HUB-COMPLETE, 6 BOLT 5000LB PAINTED	2
14	68468	WLDMT-LUG MOUNT	2
15	1030866	BOLT-HEX: 1.00 X 9.00 NC GR8 ZP	2
16	62412	BOLT-HEX: .75 X 1.75 NC GR5 ZP	8
17	1017000	NUT-TOPLOCK: .75 NC GR5 ZP	8
18	1016969	NUT-TOPLOCK: 1.00 NC GR8 ZP	2
19	52407	RATCHET JACK PAINTED BLACK	2

STABILIZER WHEELS W/ HYD (306734/307547)

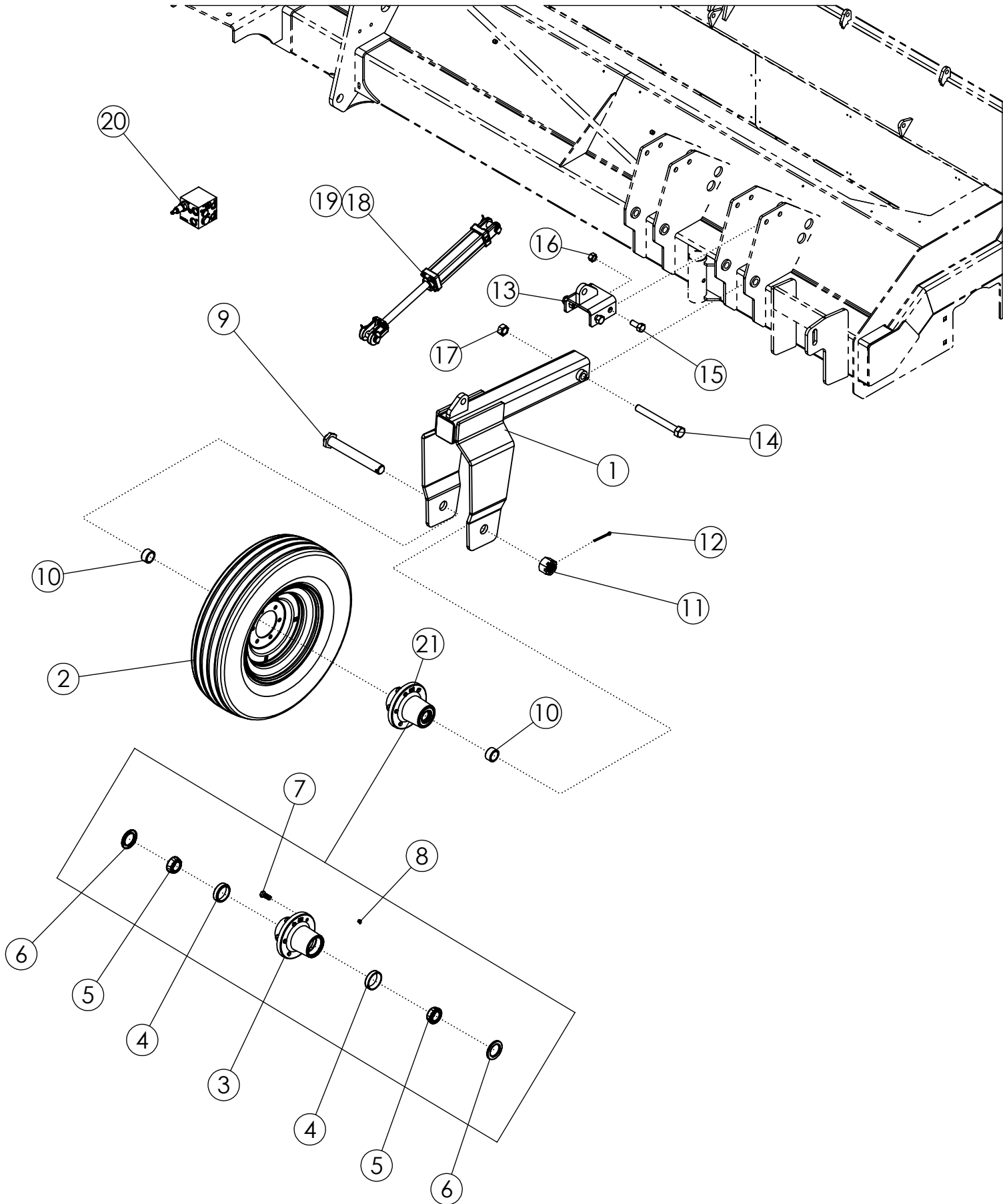

STABILIZER WHEELS W/ HYD (306734/307547)

ITEM	PART NO.	DESCRIPTION	QTY
1	306055	WLDMT-STABILIZER STRUT '50	2
2	68915	TIRE-MNTD: 6.50-16 6 PLY I-1 TITAN DURALIFE	2
3	306061	HUB-STABILIZER 5000LB	2
4	306063	BEARING-CUP	4
5	306062	BEARING-CONE 1.500 BORE	4
6	306059	SEAL-OIL CR	4
7	68931	BOLT-WHEEL LUG .562-18UNF X 1.75	12
8	1011748	ZERK-GREASE .25 UNF STRAIGHT	4
9	306048	WLDMT-STABILIZER SPINDLE ZP	2
10	306054	SPACER-SPINDLE ZP	4
11	306052	NUT-HEX: SLOT 1.500 NF GR2 ZP	2
12	306034	PIN-COTTER: .25 X 3.00 ZP	2
13	68468	WLDMT-LUG MOUNT	2
14	1030866	BOLT-HEX: 1.00 X 9.00 NC GR8 ZP	2
15	62412	BOLT-HEX: .75 X 1.75 NC GR5 ZP	8
16	1017000	NUT-TOPLOCK: .75 NC GR5 ZP	8
17	1016969	NUT-TOPLOCK: 1.00 NC GR8 ZP	2
18	307307	CYLINDER 2 X 8 CUSTOM SEAL	2
19	307565	KT-SEAL FOR 307307	
20	306758	FLOATING STRUTS VALVE	1
21	306051	HUB-COMPLETE, 6 BOLT 5000LB PAINTED	2

CASTERING STABILIZER WHEELS W/ HYD (306735/307548)

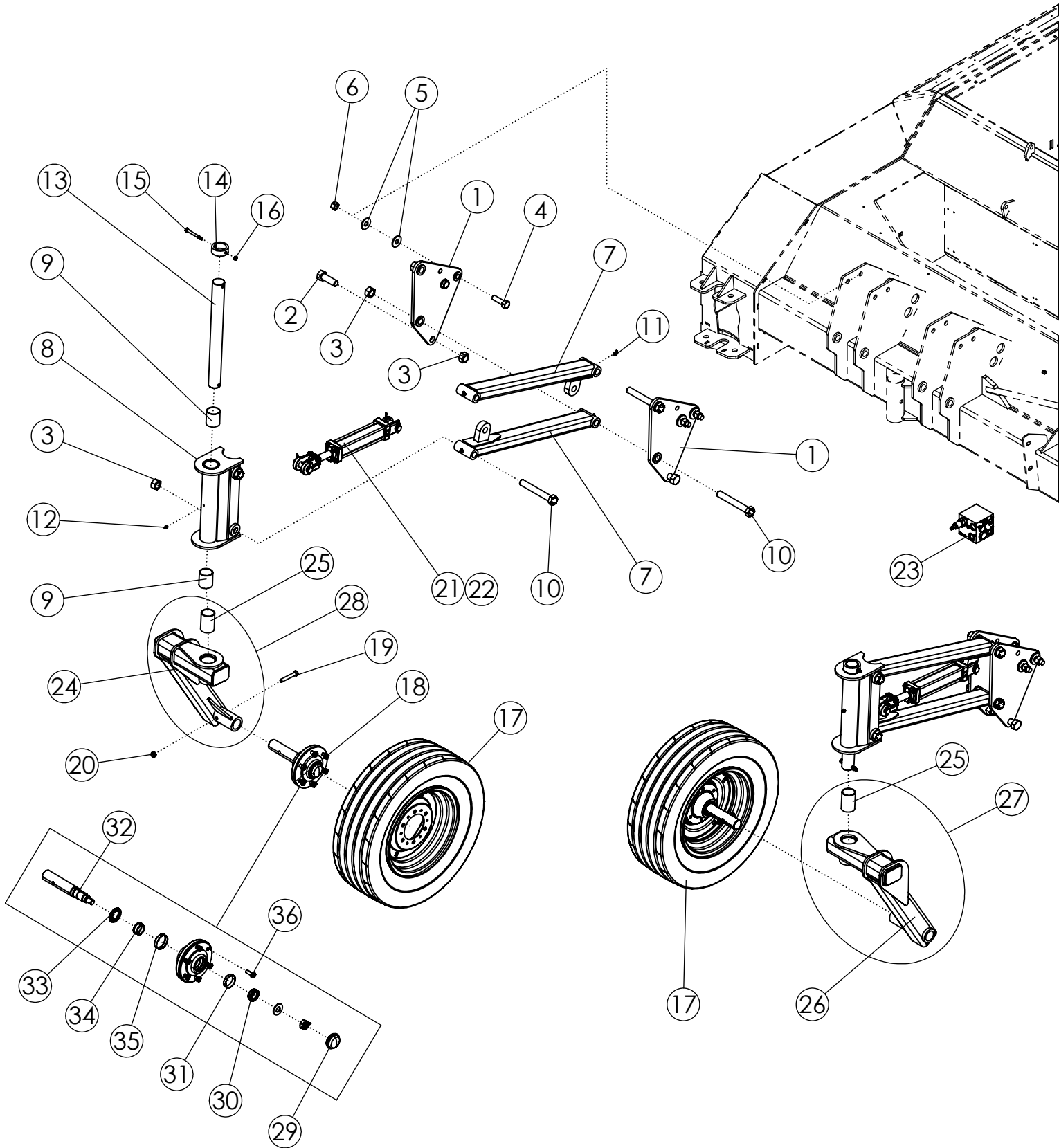

CASTERING STABILIZER WHEELS W/ HYD (306735/307548)

ITEM	PART NO.	DESCRIPTION	QTY
1	306689	WLDMT-STAB WHL EXT (50 SERIES)	4
2	1018008	BOLT-HEX: 1.00 X 3.00 NC GR8 ZP	4
3	1016969	NUT-TOPLOCK: 1.00 NC GR8 ZP	12
4	1016598	BOLT-HEX: .75 X 2.50 NC GR5 ZP	8
5	1030702	WASHER-FLAT .75 ZP	16
6	1017000	NUT-TOPLOCK: .75 NC GR5 ZP	8
7	306675	WELDMT-LINK ARM	4
8	306670	WELDT-ROTATION PIVOT	2
9	59204	BUSHING-BORED 2.5 X 2.015	4
10	1018839	BOLT-HEX: 1.00 X 7.00 NC GR8 ZP	8
11	1011747	ZERK-GREASE: .25 UNF 90 DEG	8
12	1011748	ZERK-GREASE .25 UNF STRAIGHT	2
13	306673	PIN-CASTER STRUT	2
14	306692	TUBE-CAP	2
15	58176	BOLT-HEX: .38 X 3.50 NC GR5 ZP	4
16	1016999	NUT-TOPLOCK: .38 NC GR5 ZP	4
17	307015	TIRE-MNTD: IF210/75R15 115D FIRESTONE DESTINATION FARM	2
18	WR41234	1.75" HUB AND SPINDLE	2
19	1017719	BOLT-HEX: .50 X 3.25 NC GR5 ZP	2
20	1027461	NUT-TOPLOCK: .50 NC GR5 ZP	2
21	307307	CYLINDER 2 X 8 CUSTOM SEAL	2
22	307565	KT-SEAL FOR 307307	
23	306758	FLOATING STRUTS VALVE	1
24	306682	WLDMT-SINGLE ARM RH	1
25	306769	BUSHING: 2.0" ID COMPOSITE	2
26	307168	WLDMT-SINGLE ARM LH	1
27	307169	ASSY-CASTER ARM W/ BUSHING LH	1
28	306781	ASSY-CASTER ARM W/ BUSHING RH	1
29	WR11381	CAP-DUST FOR WR41234	2
30	52245	BEARING CONE-INNER(TIMKEN ONLY)	2
31	52244	BEARING CUP-OUTER(TIMKEN ONLY)	2
32	WR41232	SPINDLE 1-3/4" DIA X 11.12 LONG	2
33	WR26121	SEAL KIT FOR 41234	2
34	WR11378	BEARING, INNER CONE	2
35	WR11379	CUP, INNER BEARING	2
36	WR88142	1/2-20 X 1.0 WHEEL BOLT GR8 ZP 3/4" HXHD	12

SIDE LINER KIT (305777)

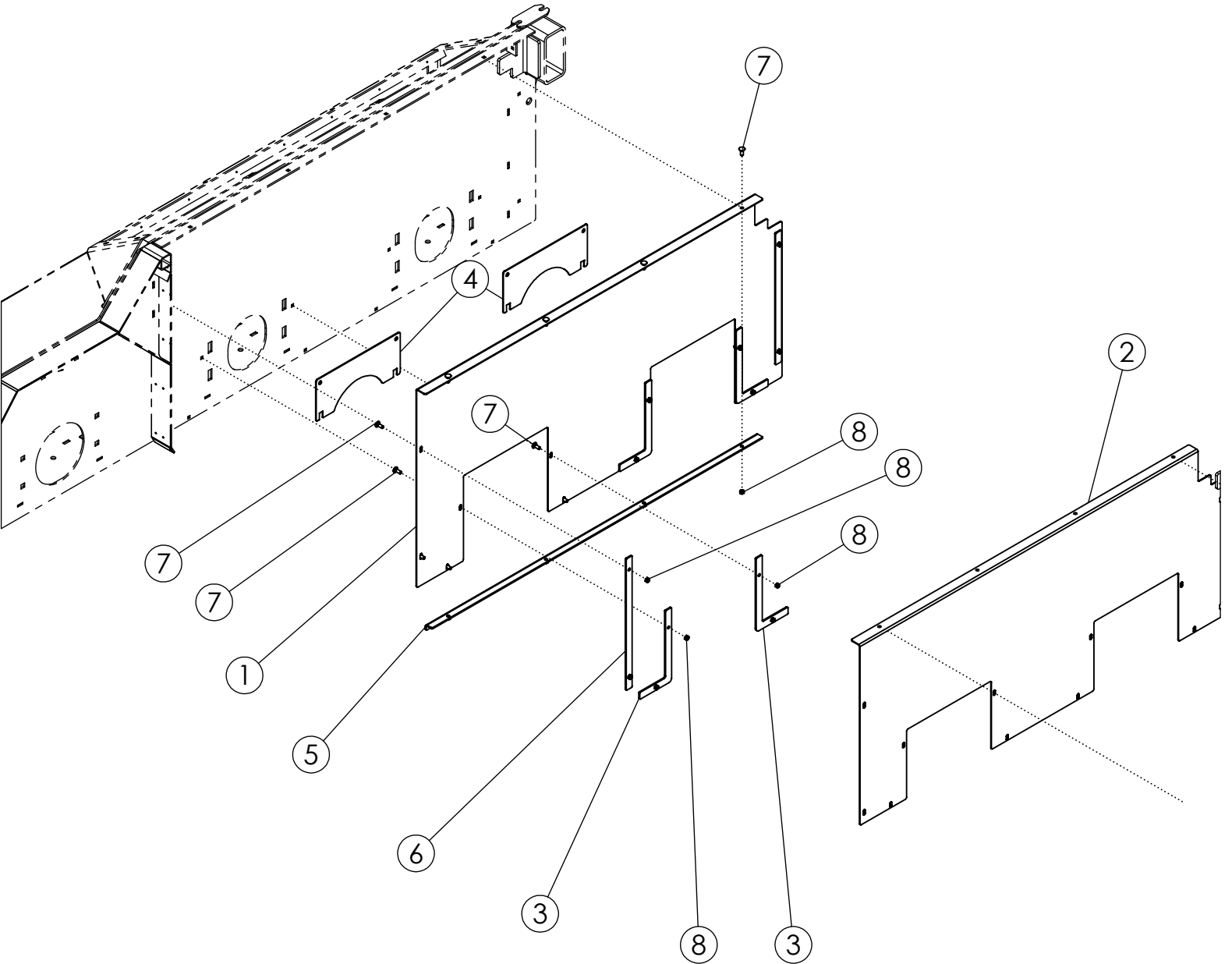

SIDE LINER KIT (305777)

ITEM	PART NO.	DESCRIPTION	QTY
1	307657	LINER-RH 3750 DEF PLASTIC	1
2	307658	LINER-LH 3750 DEF PLASTIC	1
3	307692	PLATE-RETAINER BOTTOM	8
4	307693	PLATE-LINER RETAINER DRUM	4
5	305286	PLATE- TOP RETAINER	2
6	69968	PLATE-RETAINER VERT	4
7	59488	BOLT-CRG: .38 X 1.00 NC GR5 ZP	32
8	1016999	NUT-TOPLOCK: .38 NC GR5 ZP	32

CYLINDER STOP KIT (51497)

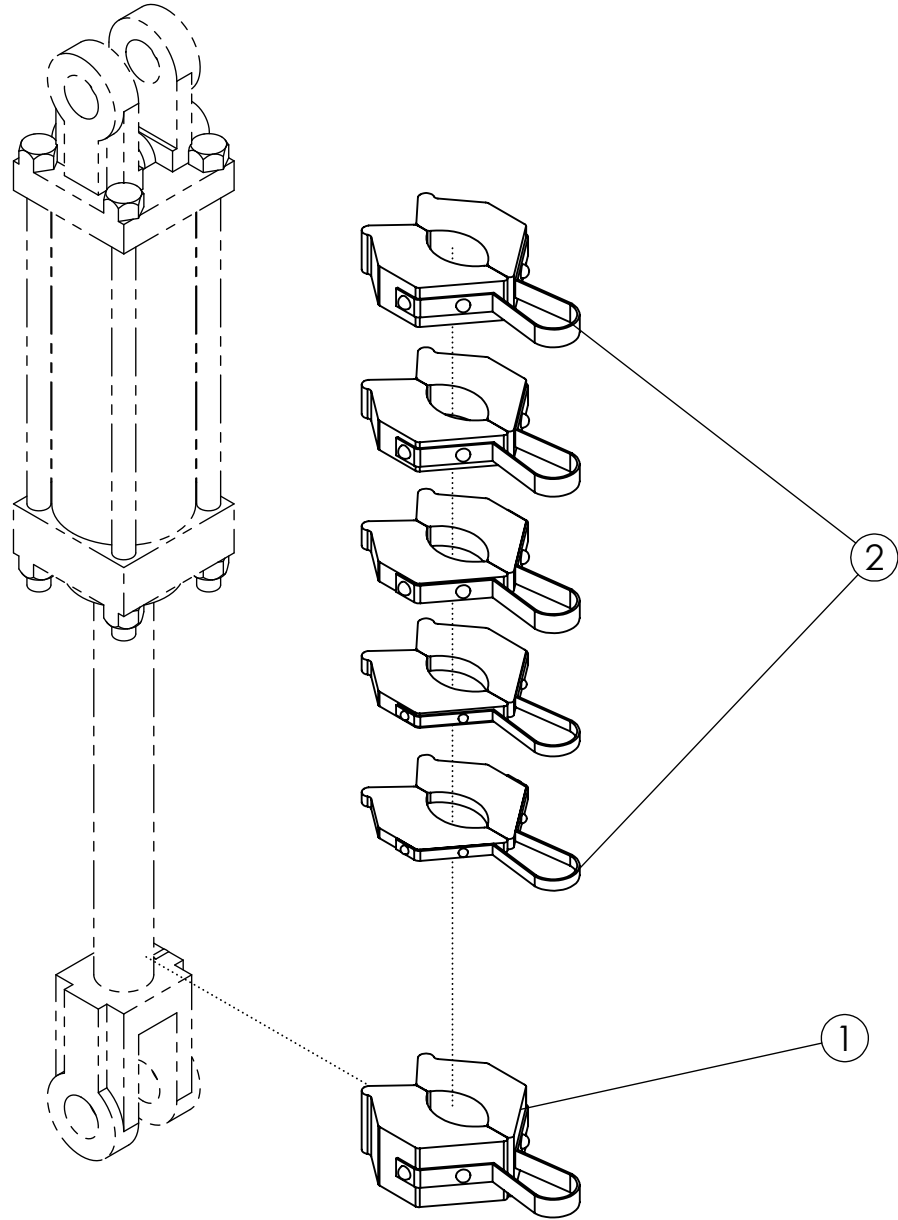

CYLINDER STOP KIT (51497)

ITEM	PART NO.	DESCRIPTION	QTY
1	54004	STOP-CYLINDER 1.5" (SILVER)	1
2	52320	CYLINDER STOP A-KT (.25 X 1.00)	1

REAR TIRE SCRAPERS (305779)

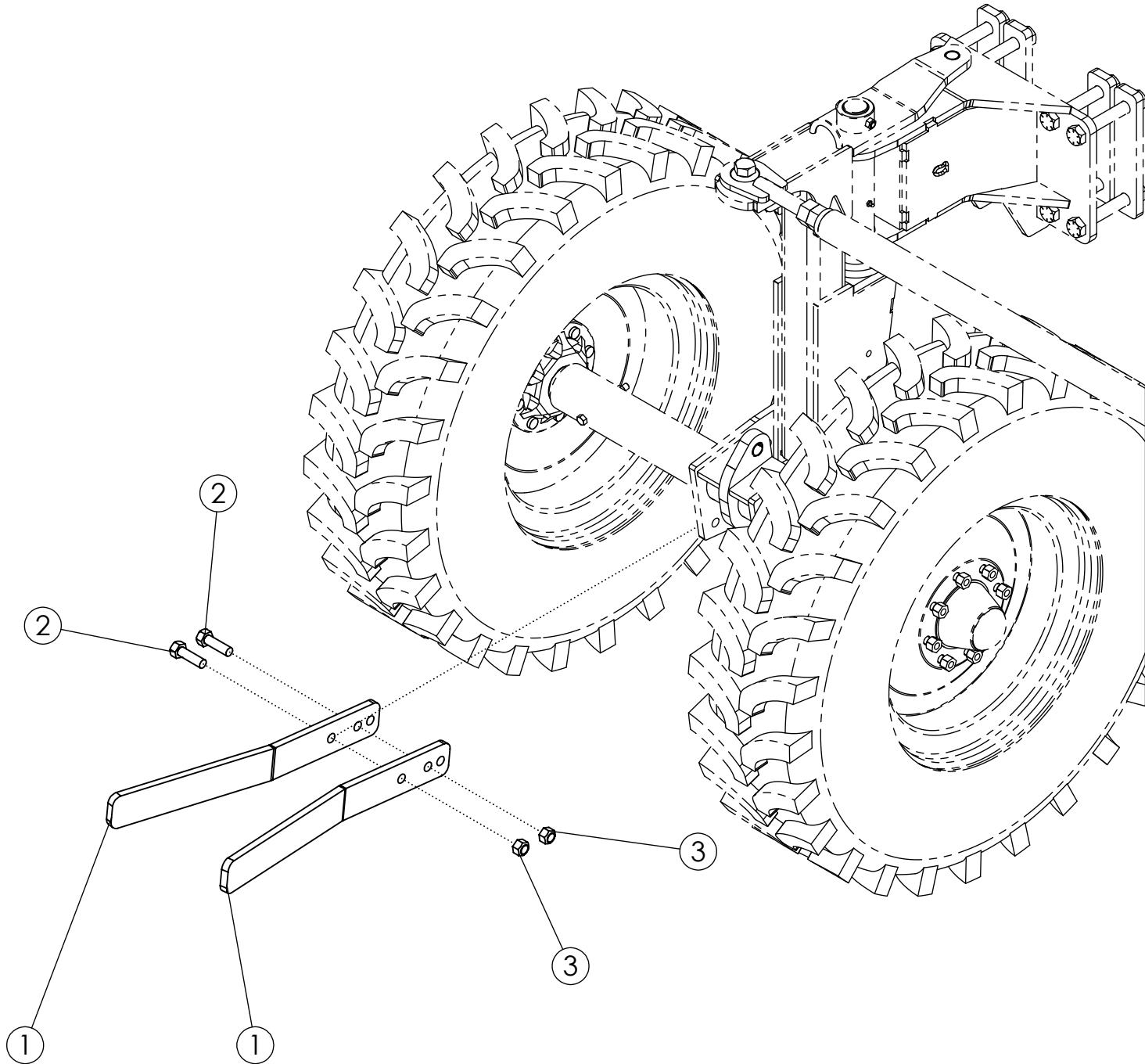

REAR TIRE SCRAPERS (305779)

ITEM	PART NO.	DESCRIPTION	QTY
1	305640	PLATE-SCRAPER 11.2-24 DEF	4
2	1016598	BOLT-HEX: .75 X 2.50 NC GR5 ZP	8
3	1017000	NUT-TOPLOCK: .75 NC GR5 ZP	8

SCALPER LOCK UP KIT (307257)

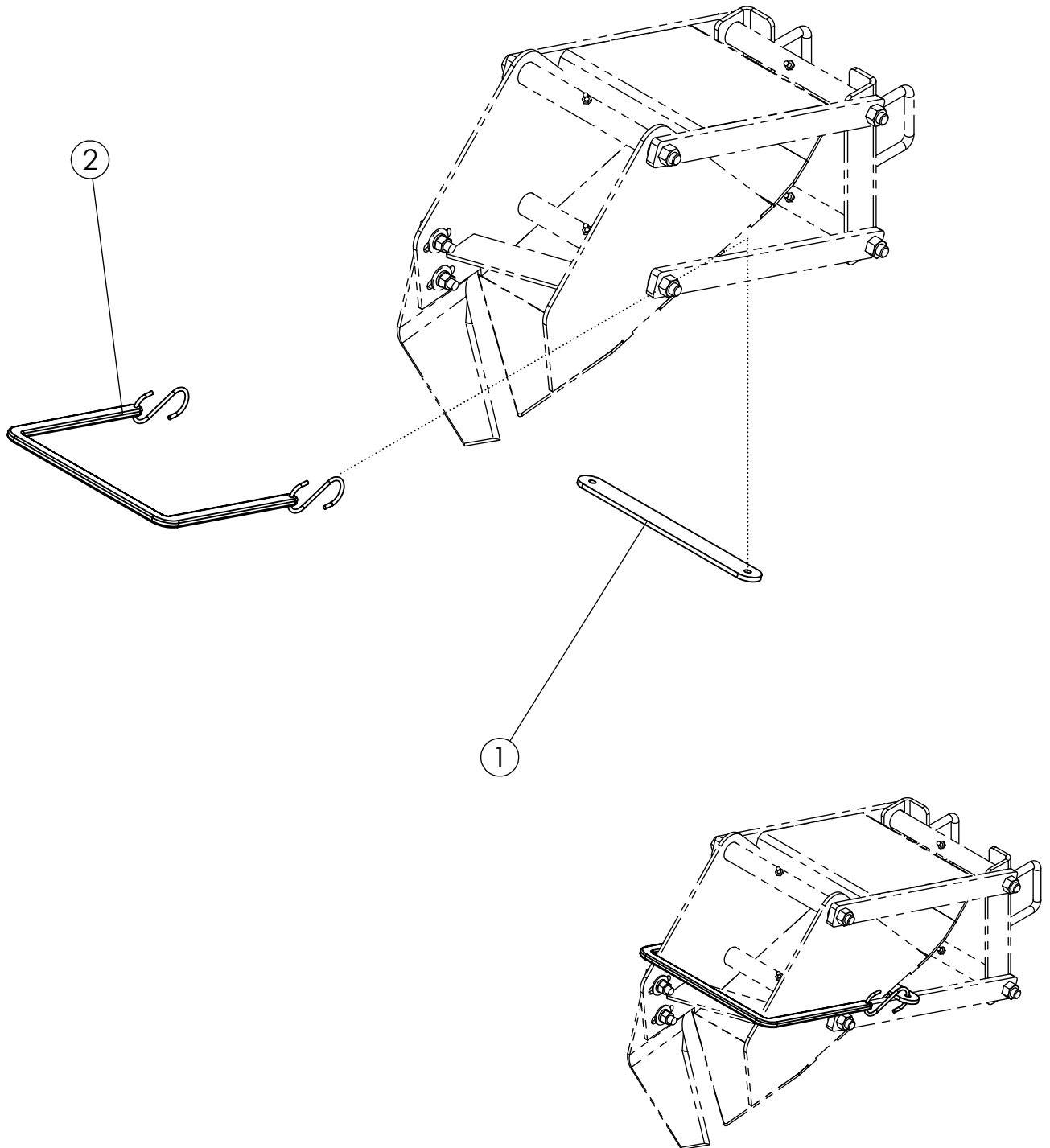

SCALPER LOCK UP KIT (307257)

ITEM	PART NO.	DESCRIPTION	QTY
1	306947	PLATE-SCALPER LOCK UP V2	1
2	306974	BUNGEE STRAP FOR SCALPER	1

JD GPS GUIDANCE MOUNTS (307875)

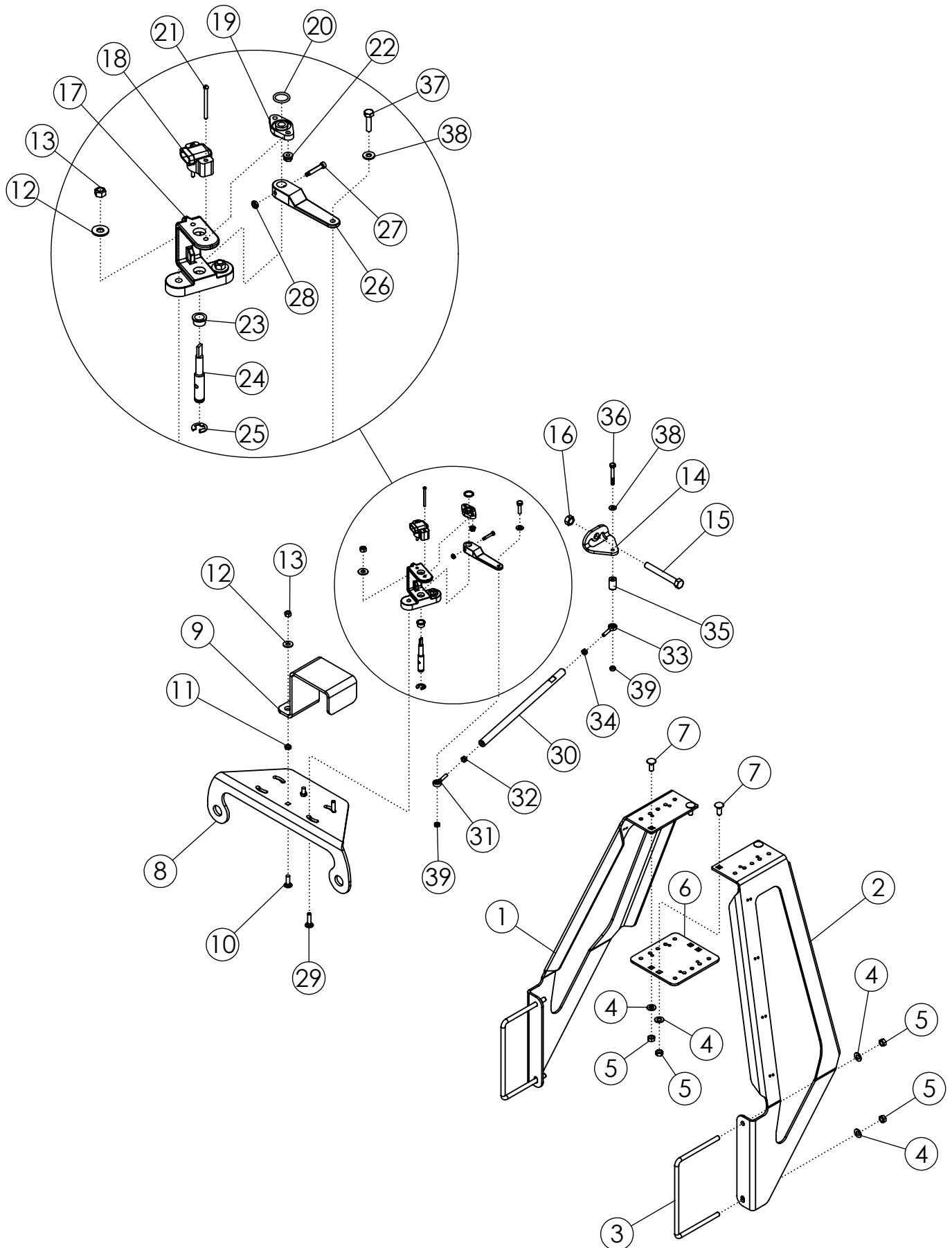

JD GPS GUIDANCE MOUNTS (307875)

ITEM	PART NO.	DESCRIPTION	QTY
1	307876	PLATE-GLOBE MOUNT RH	1
2	307877	PLATE-GLOBE MOUNT LH	1
3	64244	U-BOLT: .375 X 5.125 X 8.063 X 5.125	2
4	1014608	WASHER-FLAT: SAE .38 ZP	8
5	1016999	NUT-TOPLOCK: .38 NC GR5 ZP	8
6	307878	PLATE-GLOBE MOUNT CONNECTION	1
7	59488	BOLT-CRG: .38 X 1.00 NC GR5 ZP	4
8	307879	PLATE-SENSOR MOUNT	1
9	307880	PLATE-SENSOR SHEILD	1
10	1017255	BOLT-CRG: .31 X 1.00 NC GR5 ZP	2
11	1020506	NUT-JAM: .31 NC GR2 ZP	2
12	1011583	WASHER-FLAT: .31 ZP	4
13	301749	NUT-TOPLOCK: .31 NC GR8 ZP	4
14	307881	PLATE-SENSOR PIVOT ARM	1
15	1032507	BOLT-HEX: .50 X 4.00 NC GR5 ZP	1
16	1027461	NUT-TOPLOCK: .50 NC GR5 ZP	1
17	306821	SENSOR BRACKET-AHC	1
18	73492	SENSOR-ROTARY POSITION	1
19	306825	SUPPORT-SHAFT AHC	1
20	306826	O-RING	1
21	306836	SCREW-MACH RND: #10-24 X 2.0" PHILLIPS	2
22	1026591	NUT-K-LOCK: #10-24 NC GR2 ZP	2
23	306822	GROMMET-AHC SHAFT	1
24	306827	SHAFT-AHC ZP	1
25	306895	SNAP RING: FOR 1/2" OD- 0.46 ID X .035"	1
26	306823	LEVER-AHC	1
27	306831	BOLT-SHOULDER: 3/16" X 1.0" SHLD LNPTH X #8-32 THRD	1
28	307497	NUT-LOCK: #8-32 GR2 ZP THIN	1
29	307885	BOLT-CRG: .31 X 1.25 NC GR5 ZP	2
30	307883	ROD-SENSOR TURNBUCKLE	1
31	306829	BALL JOINT ROD END 1/4"-28 LH	1
32	307884	NUT-HEX: .25 NF GR5 ZP LH	1
33	306828	BALL JOINT ROD END 1/4"-28 RH	1
34	1011579	NUT-HEX: .25 NF GR2 ZP	1
35	307882	TUBE-SENSOR PIVOT ARM SPACER	1
36	1016211	BOLT-HEX: .25 X 2.00 NC GR5	1
37	1013423	BOLT-HEX: .25 X 1.00 NC GR5 ZP	1
38	0100979	WASHER-FLAT: SAE .25 ZP	2
39	1030946	NUT-TOPLOCK: .25 NC GR5 ZP	2

PTO CV 1-3/4" - 20 (305690)

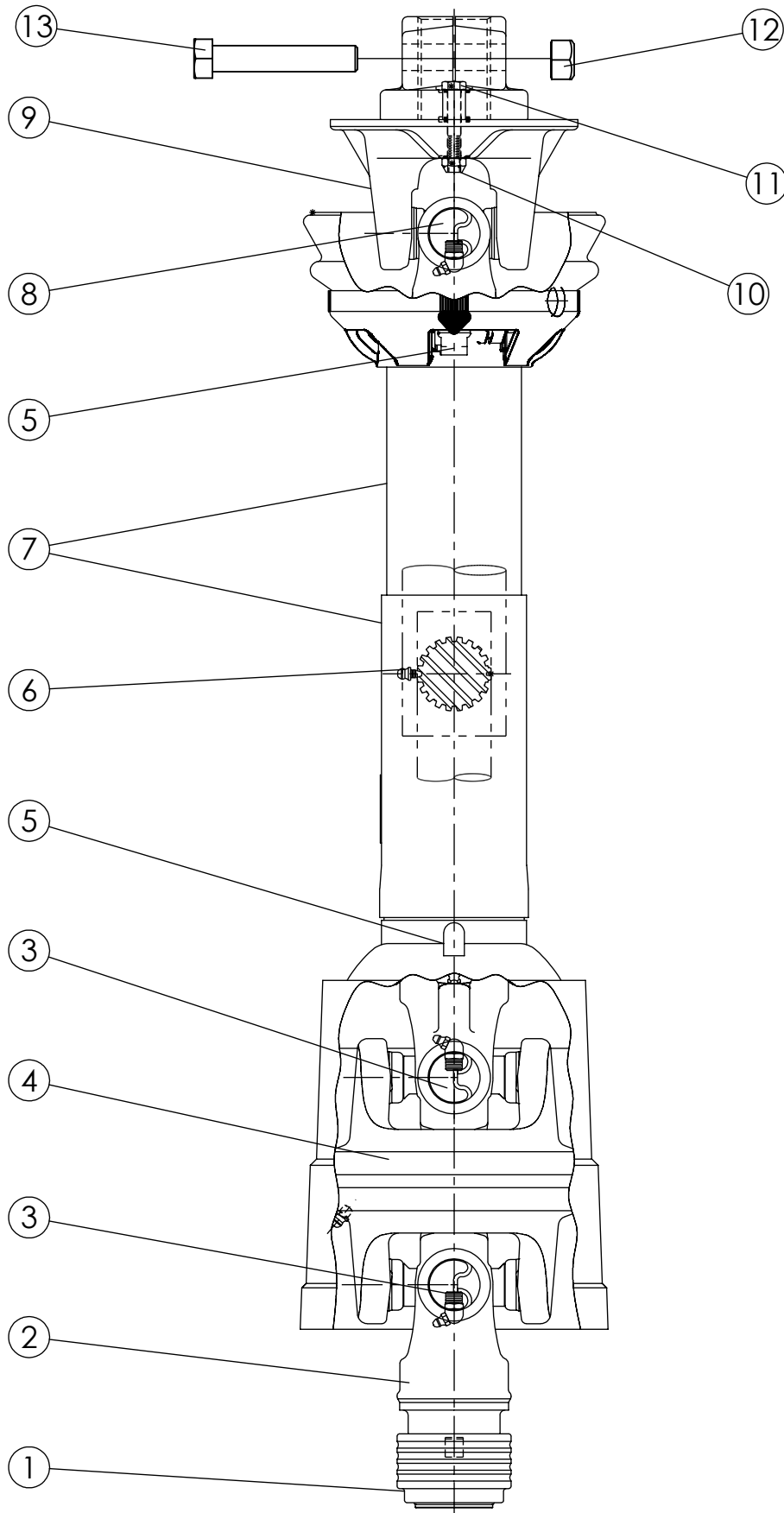

PTO CV 1-3/4" - 20 (305690)

ITEM	PART NO.	DESCRIPTION	QTY
1	62123	KT-SAFETY SLIDE LOCK REPAIR 1.750"	1
2	305902	YOKE ASSY-SAFETY SLIDE LOCK 1.750" CAT 6 CV	1
3	301841	KT-CROSS & BEARING CAT 6	2
4	305904	HOUSING-CV CENTER ASSY CAT 6	1
5	64398	KT-NYLON REPAIR UNIVERSAL	2
6	54161	ZERK-DRIVE LUBE FTG (PRESSED IN)	4
7	305906	GUARD SET-CV PTO DEF	1
8	305910	KT-CROSS & BEARING 55E SERIES	1
9	305911	ASY-BALL SHEAR DEF	1
10	1018706	NUT-TOPLOCK: .44 NC GR5 ZP	1
11	1011616	BOLT-HEX: .44 X 2.25 NC GR5 ZP	1
12	305913	NUT-FLG TOPLOCK: .625 NC GR8 ZP	2
13	305914	BOLT-FLG: .625 X 3.50 NC GR8 ZP	2

PTO STD 1-3/4" - 20 (305691)

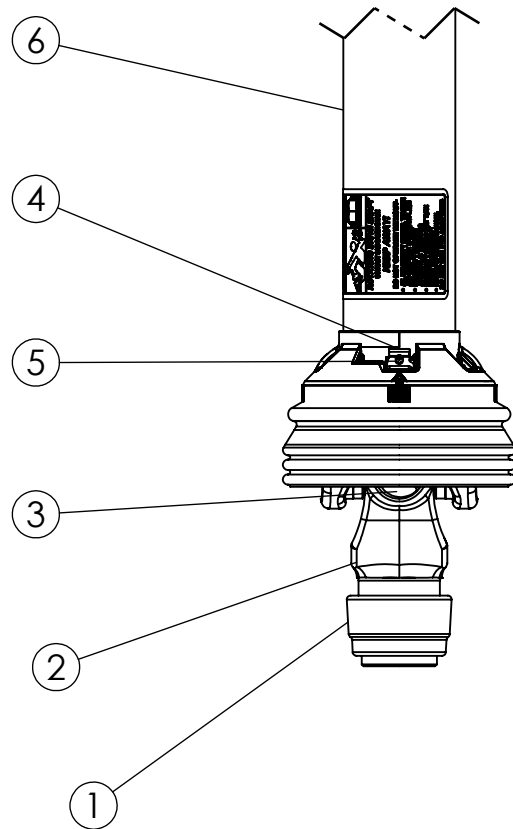
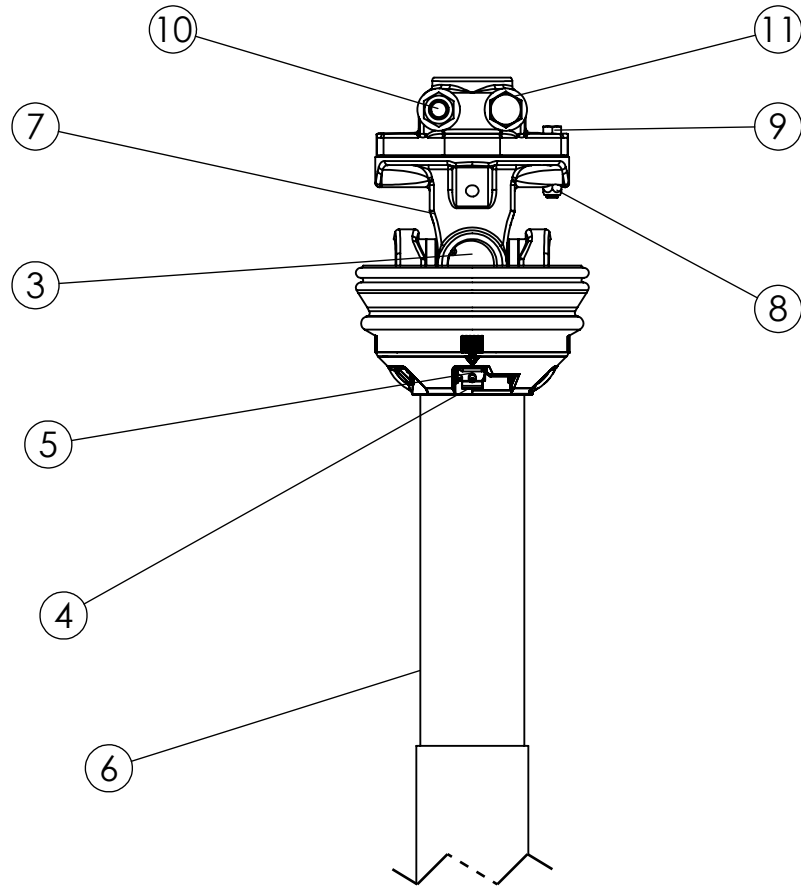

PTO STD 1-3/4" - 20 (305691)

ITEM	PART NO.	DESCRIPTION	QTY
1	62123	KT-SAFETY SLIDE LOCK REPAIR 1.750"	1
2	305915	YOKE ASSY-SAFETY SLIDE LOCK 1.750" CAT 6 STD	1
3	305910	KT-CROSS & BEARING 55E SERIES	2
4	64398	KT-NYLON REPAIR UNIVERSAL	2
5	54161	ZERK-DRIVE LUBE FTG (PRESSED IN)	4
6	305917	GUARD SET-STD PTO DEF	1
7	305911	ASSY-BALL SHEAR DEF	1
8	1018706	NUT-TOPLOCK: .44 NC GR5 ZP	1
9	1011616	BOLT-HEX: .44 X 2.25 NC GF5 ZP	1
10	305913	NUT-FLG TOPLOCK: .625 NC GR8 ZP	2
11	305914	BOLT-FLG: .625 X 3.50 NC GR8 ZP	2

GEARBOX 1:25:1 L (305601)

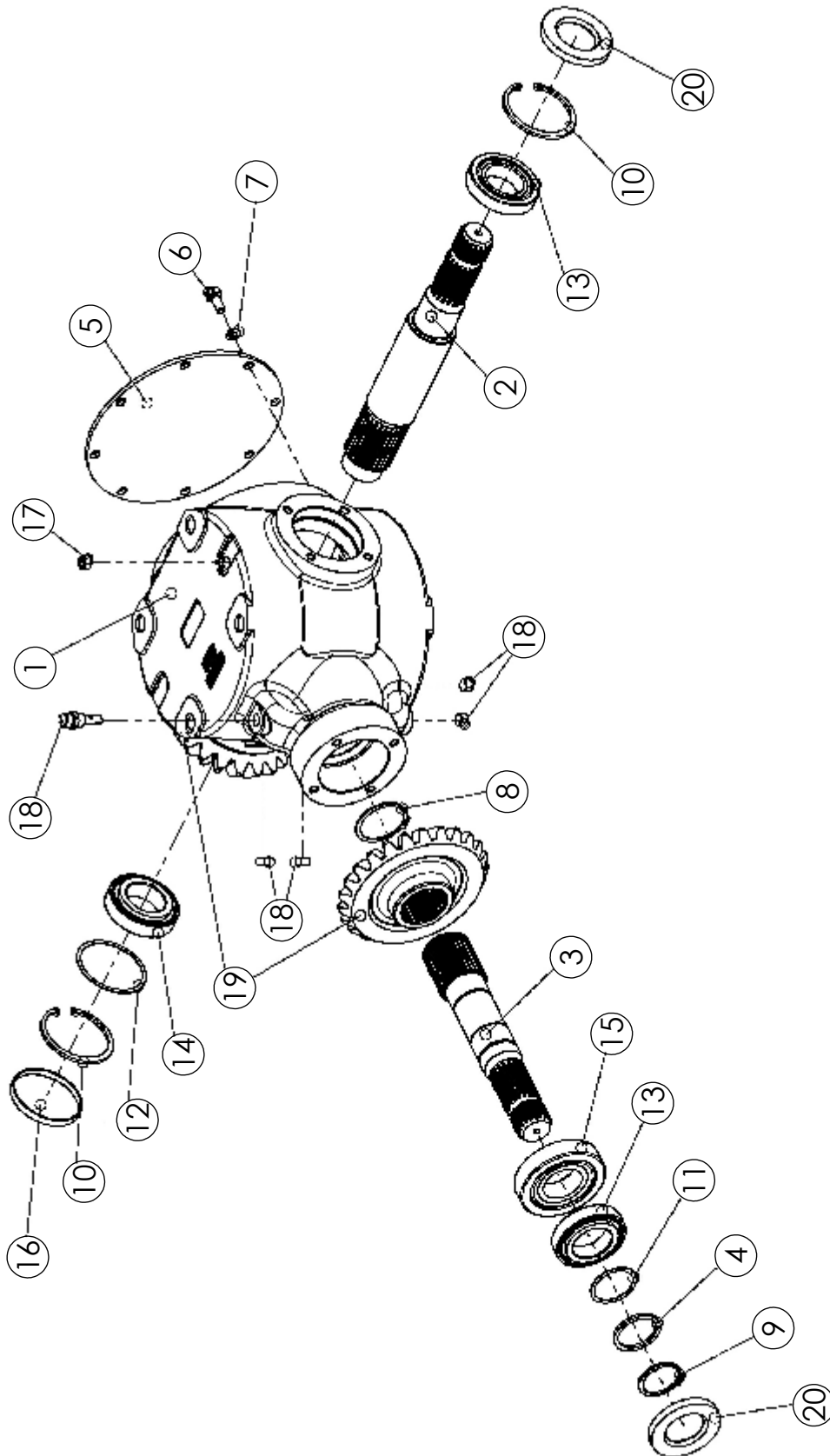

GEARBOX 1:25:1 L (305601)

ITEM	PART NO.	DESCRIPTION	QTY
1	305823	HOUSING	1
2	305826	SHAFT	1
3	305825	SHAFT Z-2155	1
4	305829	2155 G-BOX SPACER 50.2X60.3X4	1
5	305830	COVER Ø254 S2150	1
6	68185	SCREW-BOLT HEX M10 X 25 CL8.8	8
7	68186	WASHER	8
8	305832	CIRCLIP EXTERNAL 60X2.00 DIN471	1
9	305834	CIRCLIP EXTERNAL 50X3.00 DIN471/2 THICK	1
10	305835	INTERNAL SNAP RING 90X4	2
11	305836	SHIM KIT Ø50MM SHAFT (59.8X50.2)	1
12	305837	SHIM KIT Ø90MM BORE (89.8X80.2)	1
13	305839	T. ROLLER BEARING 50X90X21.75 30210	2
14	305840	T. ROLLER BEARING 50X90X24.75 32210	1
15	305841	T. ROLLER BEARING 50X110X29.25 30310	1
16	305845	OIL SEAL CAP 90X10	1
17	305846	BREATHER PLUG	1
18	54215	1025075 OIL PLUG - 3/8" BSPT (TAPERED)	5
19	305849	BEVEL GEAR SET R=1.25 S2150	1
20	305899	OIL SEAL 50X90X10	2

GEARBOX 1:1 L W/ OVERRUN CLUTCH (305602)

ITEM	PART NO.	DESCRIPTION	QTY
1	305823	HOUSING	1
2	305827	SHAFT-DLS	1
3	305825	SHAFT Z-2155	1
4	305828	SPACER 8MM S2155 W/RL	1
5	305829	2155 G-BOX SPACER 50.2X60.3X4	1
6	305830	COVER Ø254 S2150	1
7	305831	RATCHET S2155 W/RL L=60	6
8	68185	SCREW-BOLT HEX M10 X 25 CL8.8	8
9	68186	WASHER	8
10	305832	CIRCLIP EXTERNAL 60X2.00 DIN471	1
11	305833	CIRCLIP EXTERNAL 72X2.50 DIN471	1
12	305834	CIRCLIP EXTERNAL 50X3.00 DIN471/2 THICK	1
13	305835	INTERNAL SNAP RING 90X4	2
14	305836	SHIM KIT Ø50MM SHAFT (59.8X50.2)	1
15	305837	SHIM KIT Ø90MM BORE (89.8X80.2)	1
16	59960	SPRING-GEARBOX SHAFT	18
17	305839	T. ROLLER BEARING 50X90X21.75 30210	2
18	305840	T. ROLLER BEARING 50X90X24.75 32210	1
19	305841	T. ROLLER BEARING 50X110X29.25 30310	1
20	305845	OIL SEAL CAP 90X10	1
21	305846	BREATHER PLUG	1
22	54215	1025075 OIL PLUG - 3/8" BSPT (TAPERED)	5
23	305848	BEVEL GEAR SET R=1.1 -2155- RL	1
24	305899	OIL SEAL 50X90X10	2

GEARBOX 1:1.35 T (305603)

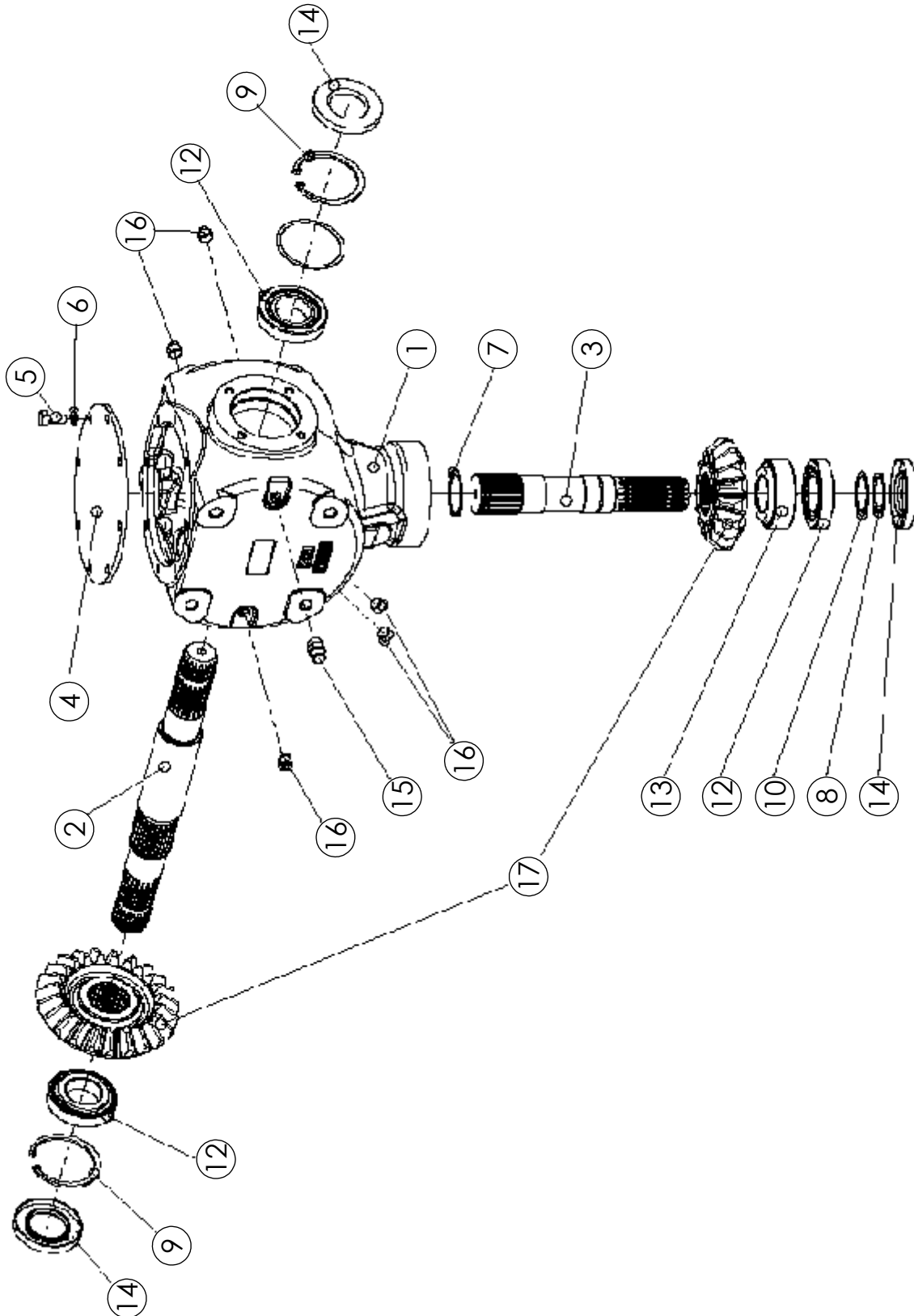

GEARBOX 1:1.35 T (305603)

ITEM	PART NO.	DESCRIPTION	QTY
1	68181	HOUSING-GEARBOX	1
2	68193	SHAFT-THRU	1
3	68194	SHAFT	1
4	68184	SLEEVE	1
5	68185	SCREW-BOLT HEX M10 X 25 CL8.8	8
6	68186	WASHER	8
7	52521	SNAP RING: EXTERNAL	1
8	54209	SNAP RING	1
9	54210	SNAP RING	2
10	64421	KT-SPACER RING	1
11	64422	KT-SPACER RING	1
12	54212	1025072 BEARING ROLLER	3
13	68187	BEARING-ROLLER	1
14	54214	1025074 SEALING RING	3
15	54204	VENT PLUG	1
16	54215	1025075 OIL PLUG - 3/8" BSPT (TAPERED)	5
17	68188	GEAR SET	1

GEARBOX 1.93:1 T (305604)

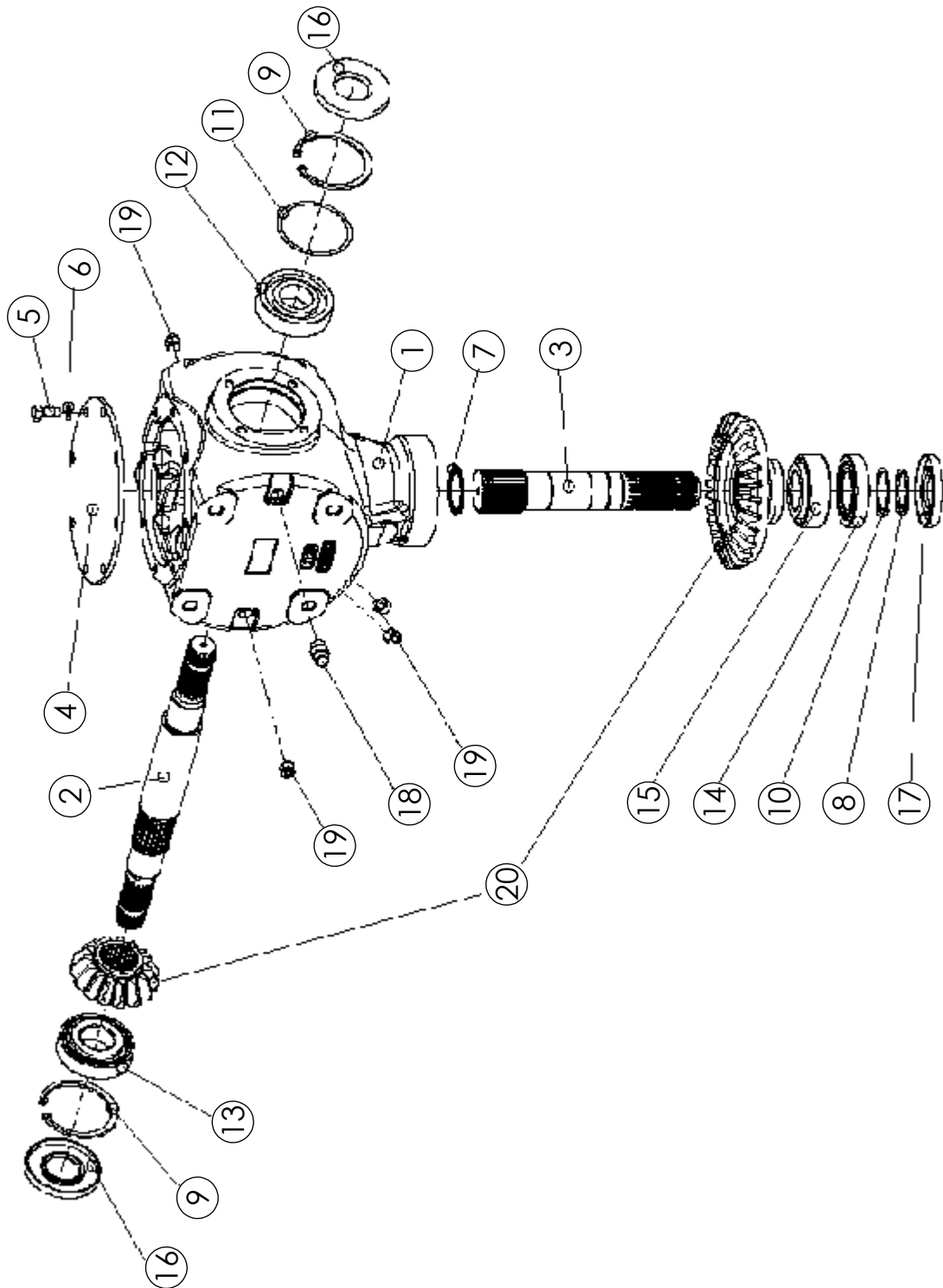

GEARBOX 1.93:1 T (305604)

ITEM	PART NO.	DESCRIPTION	QTY
1	305822	HOUSING	1
2	305824	SHAFT	1
3	68194	SHAFT	1
4	68184	SLEEVE	1
5	68185	SCREW-BOLT HEX M10 X 25 CL8.8	8
6	68186	WASHER	8
7	52521	SNAP RING: EXTERNAL	1
8	54209	SNAP RING	1
9	305835	INTERNAL SNAP RING 90X4	2
10	64421	KT-SPACER RING	1
11	305837	SHIM KIT Ø90MM BORE (89.8X80.2)	1
12	305838	BALL BEARING 40X90X23 6308	1
13	305842	T. ROLLER BEARING 40X90X25.25 30308	1
14	54212	1025072 BEARING ROLLER	1
15	68187	BEARING-ROLLER	1
16	305843	OIL SEAL 40X90X10	2
17	54214	1025074 SEALING RING	1
18	305845	OIL SEAL CAP 90X10	1
19	54215	1025075 OIL PLUG - 3/8" BSPT (TAPERED)	5
20	305847	BEVEL GEAR	1

SIDE DRIVELINE 1 3/8" - 1 3/8" (305611)

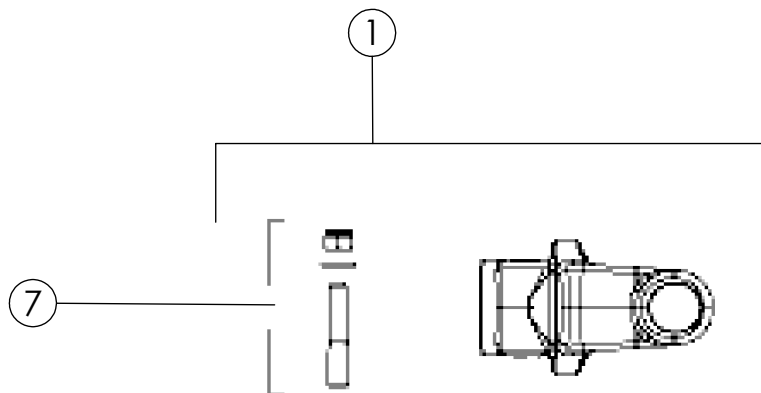
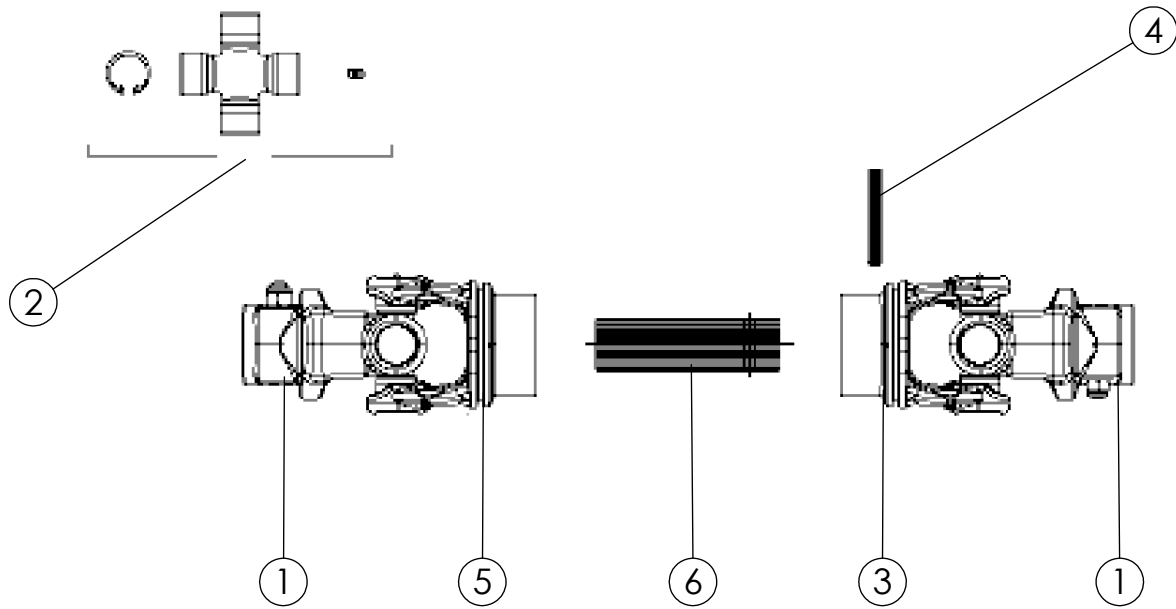

SIDE DRIVELINE 1 3/8" - 1 3/8" (305611)

ITEM	PART NO.	DESCRIPTION	QTY
1	305444	YOKE COUPLER TAPER PIN 1.375	2
2	305445	CROSS KIT	2
3	305447	YOKE S9	1
4	305446	PIN-ROLL	1
5	305448	YOKE TUBE-OUTER S9	1
6	305449	TUBE-CARDAN	1
7	305546	KT-TAPER PIN	2

SIDE DRIVELINE 1 3/4" - 1 3/8" (305612)

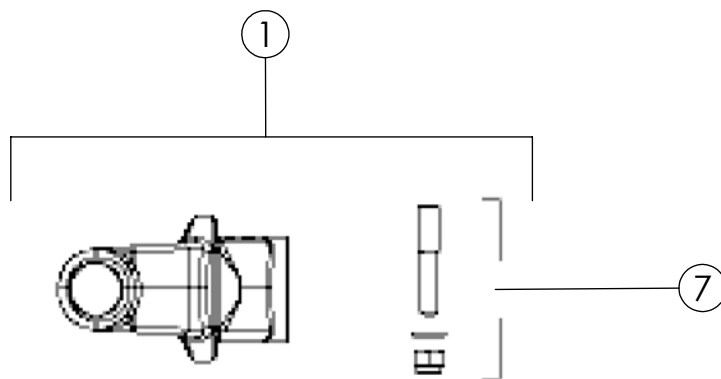
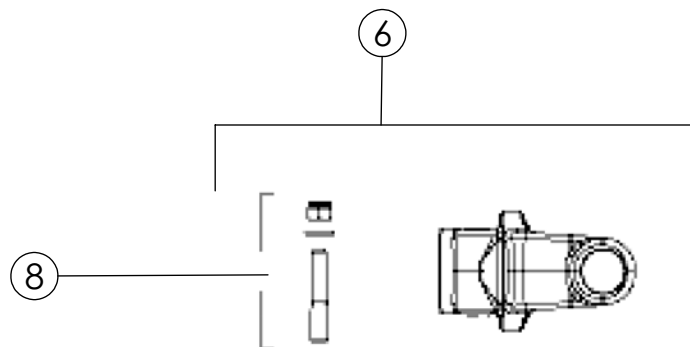
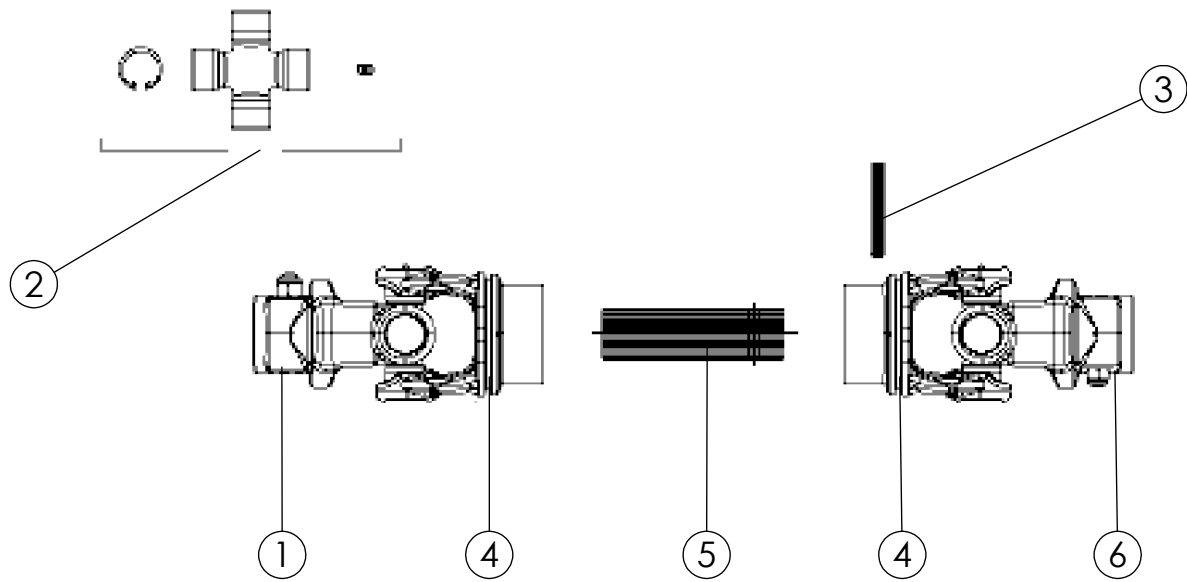

SIDE DRIVELINE 1 3/4" - 1 3/8" (305612)

ITEM	PART NO.	DESCRIPTION	QTY
1	68731	YOKE-COUPLER TAPER PIN 1.750	1
2	305445	CROSS KIT	2
3	305446	PIN-ROLL	1
4	305448	YOKE TUBE-OUTER S9	2
5	305549	TUBE-CARDAN	1
6	305444	YOKE COUPLER TAPER PIN 1.375	1
7	68782	KT-TAPER PIN 1.750	1
8	305546	KT-TAPER PIN	1

U-JOINT COUPLER (68443)

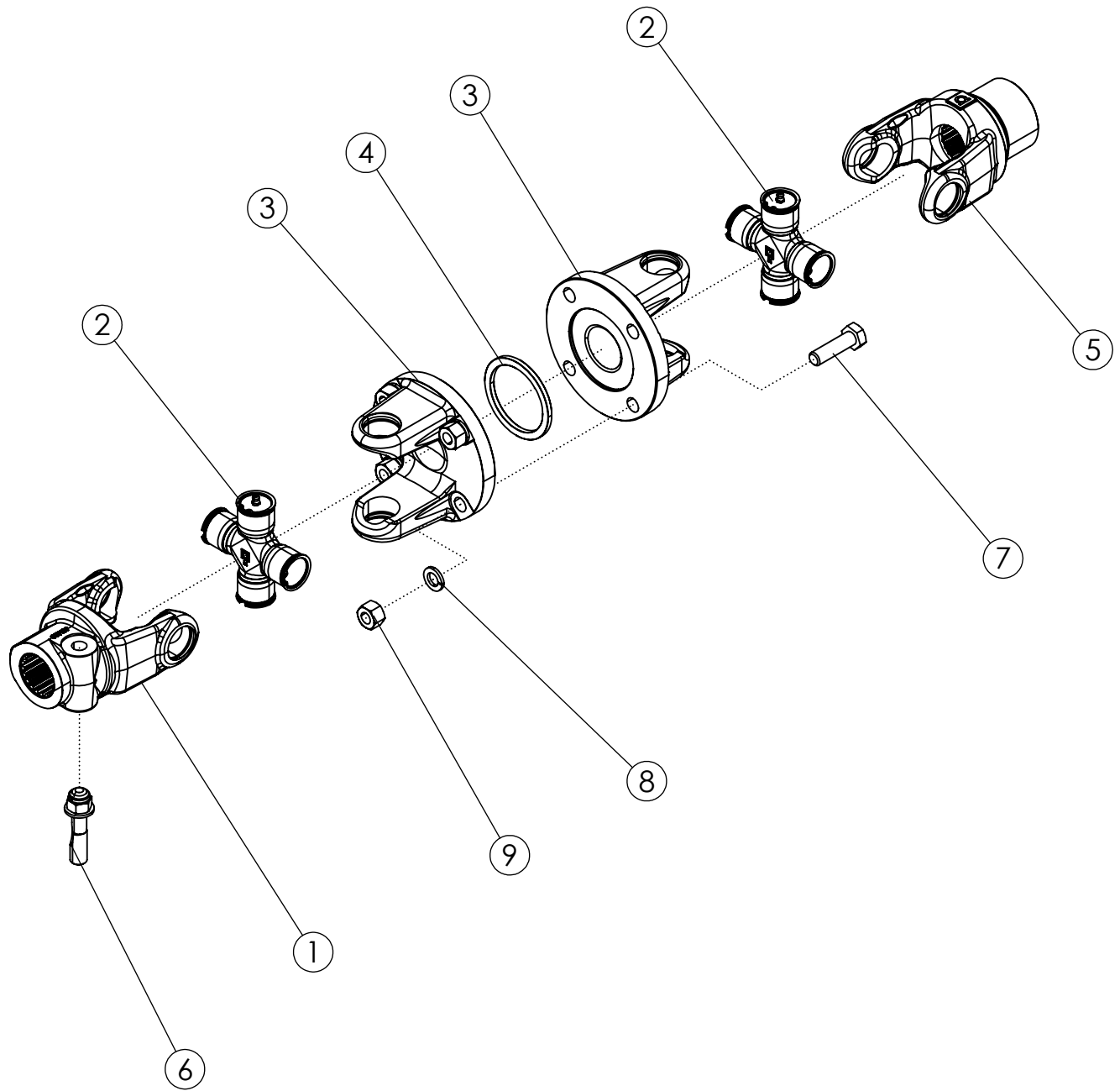

U-JOINT COUPLER (68443)

ITEM	PART NO.	DESCRIPTION	QTY
1	68731	YOKE-COUPLER TAPER PIN 1.750	1
2	54235	1025104 CROSS KT	2
3	68780	FLANGE-YOKE COUPLER	2
4	68781	PLATE-LINER COUPLER	1
5	68732	YOKE COUPLER 1.750	1
6	68782	KT-TAPER PIN 1.750	1
7	69019	BOLT-HEX: M14 X 2.0 X L50 CL8.8 ZP	4
8	68591	WASHER-LOCK: M14	4
9	68444	NUT-HEX: M14	4

HYDRAULIC COUPLER ASSEMBLY

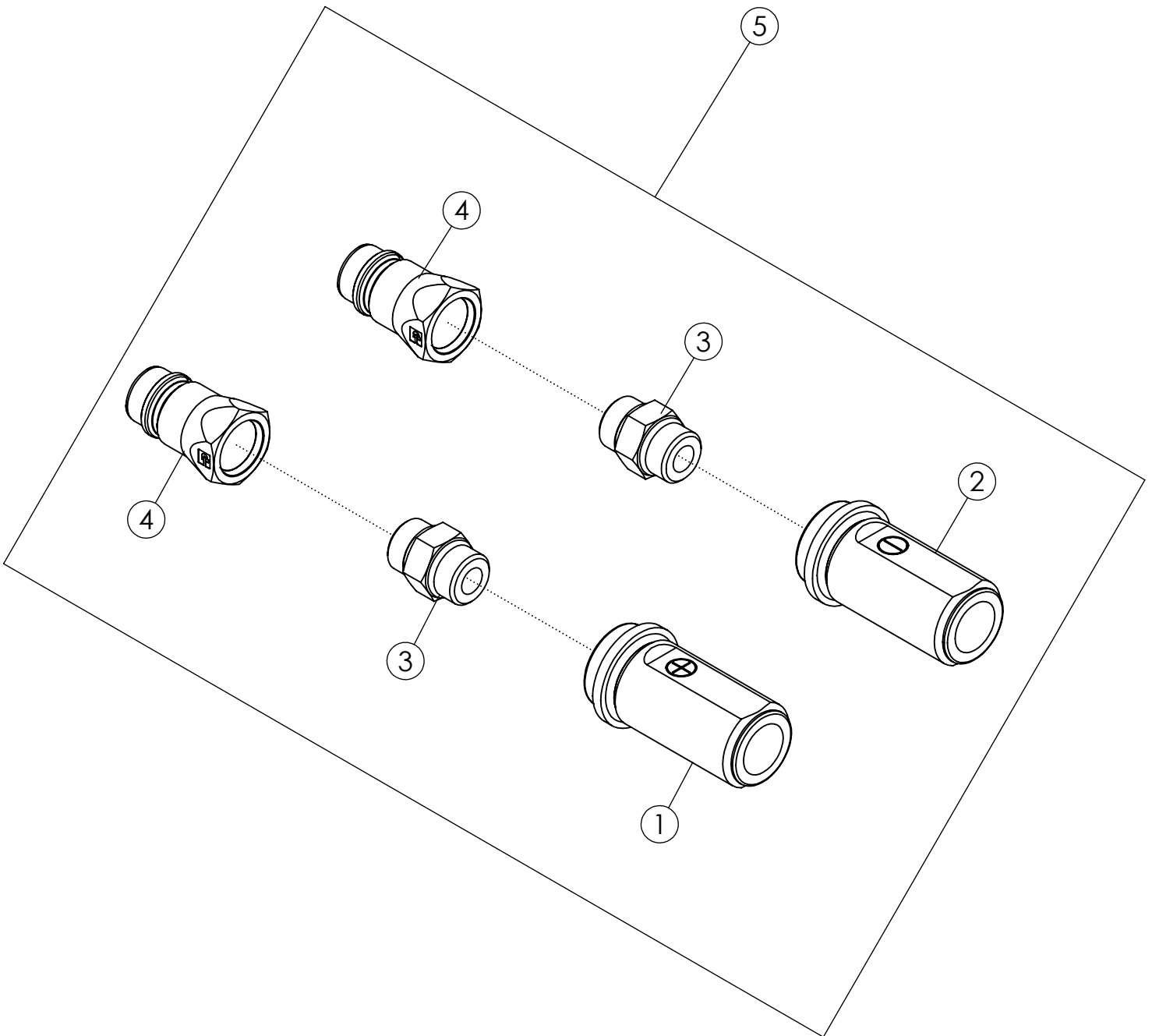

HYDRAULIC COUPLER ASSEMBLY

ITEM	PART NO.	DESCRIPTION	QTY
1	304170	HYD LABEL: 8FB-8FB RED (+)	1
	304172	HYD LABEL: 8FB-8FB BLACK (+)	1
	304174	HYD LABEL: 8FB-8FB BLUE (+)	1
	304176	HYD LABEL: 8FB-8FB GREEN (+)	1
	304178	HYD LABEL: 8FB-8FB GOLD (+)	1
	304180	HYD LABEL: 8FB-8FB SILVER (+)	1
	304182	HYD LABEL: 8FB-8FB PURPLE (+)	1
2	304171	HYD LABEL: 8FB-8FB RED (-)	1
	304173	HYD LABEL: 8FB-8FB BLACK (-)	1
	304175	HYD LABEL: 8FB-8FB BLUE (-)	1
	304177	HYD LABEL: 8FB-8FB GREEN (-)	1
	304179	HYD LABEL: 8FB-8FB GOLD (-)	1
	304181	HYD LABEL: 8FB-8FB SILVER (-)	1
	304183	HYD LABEL: 8FB-8FB PURPLE (-)	1
3	304184	FTG-ADAPTER: 8MB-8MB SOLID	2
4	36290	PIONEER TIP 8010-15P (#8 ORB)	2
5	304185	ASSY-TRACTOR HYD COUPLERS (RED)	1
	304186	ASSY-TRACTOR HYD COUPLERS (BLACK)	1
	304187	ASSY-TRACTOR HYD COUPLERS (BLUE)	1
	304188	ASSY-TRACTOR HYD COUPLERS (GREEN)	1
	304189	ASSY-TRACTOR HYD COUPLERS (GOLD)	1
	304190	ASSY-TRACTOR HYD COUPLERS (SILVER)	1
	304191	ASSY-TRACTOR HYD COUPLERS (PURPLE)	1

SNAP RING PLIERS (69055)

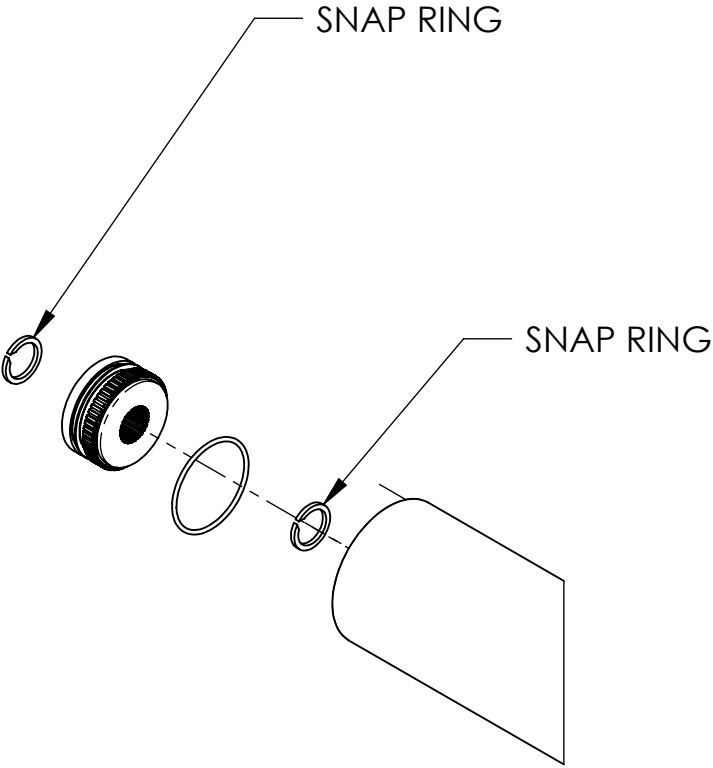
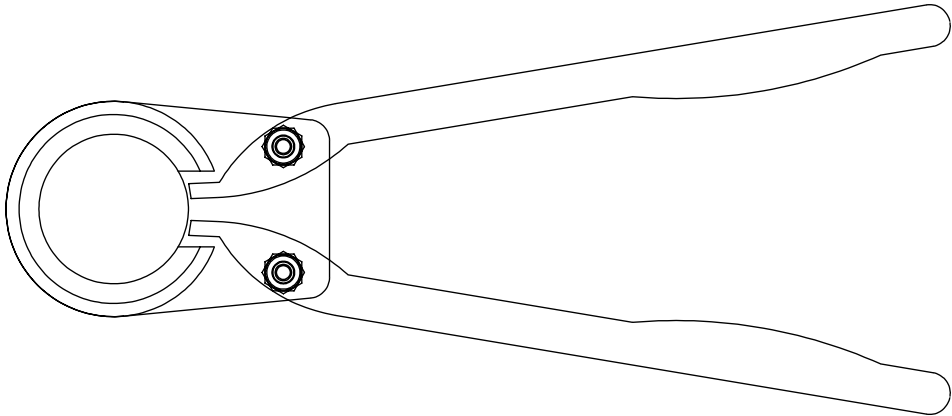

SHAFT REMOVED FOR CLARITY