

# OPERATING MANUAL

2026  
BEET CART



2800 7<sup>th</sup> Avenue North  
Fargo, ND 58108

Phone: (701) 232-4199  
Fax: (701) 234-1716  
[www.amitytech.com](http://www.amitytech.com)

This page is intentionally left blank.

AMITY TECHNOLOGY LLC LIMITED WARRANTY TERMS AND CONDITIONS – UNITED STATES

EFFECTIVE FOR EQUIPMENT RETAILED AND DELIVERED AFTER JUNE 1, 2020

**WHAT IS WARRANTED** Amity Technology warrants its new equipment to be free of defects in material and workmanship at time of delivery to the first retail purchaser, renter, or lessee. Amity Technology warrants any new or unused part which is manufactured by Amity Technology for use in an Amity Technology machine, jointly referred to as "Products", whether such Product is purchased through an authorized Amity Technology dealer or directly from Amity Technology. Under this Warranty, Amity Technology will repair or replace, as it chooses in its sole discretion, any covered Product, or any component thereof, which Amity determines to be defective. These terms apply to all Amity Technology brands of new equipment originally marketed in the United States.

**WARRANTY PERIOD**

- 12 Months from the date of delivery to the first retail purchaser, renter or lessee.

**EXCEPTIONS FROM THIS WARRANTY**

- **Freight Charges** - This warranty does not cover freight charges.
- **Improvements, Changes, or Discontinuance** Amity Technology reserves the right to make changes and improvements in design or changes in specifications at any time to any product without incurring any obligations to owners of products previously sold.
- **Repairs and Maintenance Not Covered Under Warranty** - This warranty does not cover conditions resulting from misuse, natural calamities, use of non-Amity Technology parts, negligence, alteration, accident, use of unapproved attachments, usage which is contrary to the intended purposes, or conditions caused by failure to perform required maintenance. Replacement of Wear or Maintenance items (unless defective) such as but not limited to, filters, hoses, belts, lubricants, light bulbs, wheel alignment, tightening of nuts, belts, bolts, and fittings, service tune-up, computer parameter adjustments and general adjustments which may from time to time be required are not covered.
- **Rubber Tire Warranty** - Rubber tires are warranted directly by the respective manufacturer only and not by Amity Technology.

**OWNER'S OBLIGATION**

It is the responsibility of the Owner to transport the equipment or parts to the service shop of an authorized Amity Technology Dealer or alternatively to reimburse the Dealer for any travel or transportation expense involved in fulfilling this warranty. This Warranty does NOT cover rental of replacement equipment during the repair period, damage to products which have been declared a total loss and subsequently salvaged, overtime labor charges, freight charges for replacement parts, or special handling requirements (such as, but not limited to, the use of cranes).

**EXCLUSIVE EFFECT OF WARRANTY AND LIMITATION OF LIABILITY**

THIS WARRANTY IS IN LIEU OF ALL WARRANTIES OF MERCHANTABILITY, FITNESS FOR A PURPOSE OR OTHER REPRESENTATIONS, WARRANTIES OR CONDITIONS, EXPRESSED OR IMPLIED. The remedies of the Owner set forth herein are exclusive. The Company neither assumes nor authorizes any person to assume for it any other obligation or liability in connection with the sale of covered machines. Correction of defects, in the manner and for applicable period of time provided above, shall constitute fulfillment of all responsibilities of Amity Technology to the Owner, and Amity Technology shall not be liable for negligence under contract or in any manner with respect to such machines. IN NO EVENT SHALL THE OWNER BE ENTITLED TO RECOVER FOR INCIDENTAL, SPECIAL OR CONSEQUENTIAL DAMAGES SUCH AS BUT NOT LIMITED TO, LOSS OF CROPS, LOSS OF PROFITS OR REVENUE, OTHER COMMERCIAL LOSSES, INCONVENIENCE OR COST OF RENTAL OR REPLACEMENT EQUIPMENT.

Some States or Provinces do not permit limitations or exclusions of implied warranties or incidental or consequential damages, so the limitations or exclusions in this warranty may not apply.

**Additional Warranty Information**

**New Equipment Warranty** - Equipment is eligible for warranty service only if it qualifies under the provisions of the New Equipment Warranty. The selling dealer will deliver this Warranty to the original retail purchaser at the time of sale, and the dealer will register the sale and Warranty with Amity Technology LLC.

**Subsequent Owners** - This Warranty covers the first retail purchaser and all subsequent owners of the equipment during the specified warranty period. Should the Amity Technology Dealer sell this equipment to a subsequent owner, the Dealer must deliver the warranty document to the subsequent owner so the subsequent owner can register ownership with Amity Technology and obtain the remaining warranty benefits, if available, with no intermission in the Warranty Period. Subsequent Owner Procedure will apply. It is the responsibility of the subsequent owner to transport the equipment to the service shop of an authorized Amity Technology Dealer or alternatively to reimburse the Dealer for any travel or transportation expense involved in fulfilling this warranty. This Warranty does NOT cover charges for rental or replacement equipment during the repair period, products which have been declared a total loss and subsequently salvaged, overtime labor charges, freight charges for replacement parts, or units sold at auction.

**Warranty Service** - To be covered by Warranty, service must be performed by an authorized Amity Technology Dealer. It is recommended that you obtain warranty service from the Dealer who sold you the equipment because of that Dealer's continued interest in you as a valued customer. In the event this is not possible, warranty service may be performed by any other authorized Amity Technology Dealers in the United States or Canada. It is the responsibility of the Owner to transport the equipment to the service shop of an authorized Amity Technology Dealer or alternatively to reimburse the Dealer for any travel or transportation expense involved in fulfilling this warranty.

**Maintenance Service** - The Owner's Manual furnished to you with the equipment at the time of delivery contains important maintenance and service information. You must read the manual carefully and follow all the maintenance and service recommendations. Doing so will result in greater satisfaction with your equipment and help avoid service and warranty problems. Please remember that failures due to improper maintenance of your equipment are not covered by warranty.

**Maintenance Inspections** - To insure the continued best performance from your agricultural equipment, we recommend that you arrange to make your equipment available to your selling Dealer for a maintenance inspection 30 days prior to warranty expiration.

This page is intentionally left blank.

## TABLE OF CONTENTS

---

<b>WARRANTY</b> .....	ii	<b>7.0 ADJUSTMENTS</b> .....	7-1
<b>TABLE OF CONTENTS</b> .....	iv	7.1 Floor Chain.....	7-1
<b>1.0 INTRODUCTION</b> .....	1-1	7.2 Elevator.....	7-2
1.1 General Information.....	1-1	7.2.1 Belted Chain .....	7-2
1.2 Serial Number.....	1-1	7.2.2 Tension System.....	7-3
<b>2.0 SAFETY</b> .....	2-1	7.2.3 Beet Deflector.....	7-4
2.1 Recognizing Safety Information in Manual.....	2-1	7.2.4 Stop Bolts.....	7-4
2.2 General Harvester Safety.....	2-1	7.2.5 Plastic Puck.....	7-5
2.3 Maintenance and Operating Safety.....	2-2	7.2.6 Feed Roller.....	7-5
2.4 Hydraulic Safety.....	2-3	7.3 Floors.....	7-6
2.5 Transport Safety.....	2-3	7.3.1 Floor Shaft.....	7-6
2.6 Safety Decals.....	2-4	7.3.2 Floor Rubber Guards.....	7-6
<b>3.0 SPECIFICATIONS</b> .....	3-1	<b>8.0 TRANSPORTATION</b> .....	8-1
3.1 Cart Specifications.....	3-1	8.1 Warning Lights.....	8-1
3.1.1 Track Size.....	3-1	8.2 Preparing for Transport.....	8-1
3.2 Tractor Specifications.....	3-1	<b>9.0 CLEANING</b> .....	9-1
<b>4.0 PREPARATION</b> .....	4-1	9.1 Elevator Drive Sprocket.....	9-1
4.1 Tractor Preparation.....	4-1	9.2 Center/Feed Roller Drive Area.....	9-1
4.1.1 Three-Point Hitch Position.....	4-1	9.3 Floor Chain.....	9-1
4.2 Cart Preparation.....	4-1	<b>10.0 STORAGE</b> .....	10-1
4.2.1 Elevator Hydraulic Value Control Box.....	4-1	10.1 End of Season.....	10-1
4.2.2 Shield Placement.....	4-1	10.2 Beginning of Season.....	10-1
4.2.3 Gearbox Oil Level.....	4-1	<b>11.0 LUBRICATION AND MAINTENANCE</b> .....	11-1
4.2.4 Greasing.....	4-1	11.1 General Maintenance Information.....	11-1
<b>5.0 ATTACHING AND DETACHING</b> .....	5-1	11.1.1 Grease.....	11-1
5.1 Attaching Hydraulic and Electrical Systems.....	5-1	11.2 U Joints.....	11-1
5.2 Attaching Cart to Tractor Drawbar.....	5-1	11.3 Floor Drag Chain.....	11-1
5.3 Using Stands.....	5-2	11.4 Gearbox Oil Level.....	11-2
<b>6.0 OPERATING THE HARVESTER</b> .....	6-1	11.5 Breather.....	11-2
6.1 Cart Components.....	6-1	11.6 Servicing Intervals.....	11-3
6.1.1 Front and Rear Floors.....	6-1	11.7 Lubrication Chart.....	11-8
6.1.2 Center Floor.....	6-1	<b>12.0 OPTIONS</b> .....	12-1
6.1.3 Feed Roller.....	6-1	12.1 Scale.....	12-1
6.1.4 Elevator.....	6-2	12.2 PTO.....	12-1
6.1.5 Beet Deflector.....	6-3	<b>13.0 APPENDICES</b> .....	13-1
6.1.6 Stands.....	6-3	13.1 Conversions.....	13-1
6.2 Field Start Up.....	6-4	13.2 Belted Chain Splice Procedure.....	13-1
6.2.1 Regular Field Start Up.....	6-4	13.3 Torque Wrench Effective Length.....	13-2
6.2.2 Cold Start Up.....	6-4		
6.3 Field Operating Speed.....	6-5		
6.4 Turning Radius.....	6-5		
6.5 Unloaded Into Trucks.....	6-5		
6.6 Unloading Onto the Ground.....	6-6		
6.7 Break-in Period.....	6-7		
6.8 Field Cleaning.....	6-7		
6.9 Field Shutdown.....	6-7		

# **1.0 INTRODUCTION**

## **1.1 General Information**

Read this manual carefully to learn how to operate and service your machine correctly. Failure to read this manual can result in personal injury or equipment damage.

This manual is a permanent part of your machine and should remain with the machine when you sell it.

Measurements in this manual are given in both customary U.S. units and metric equivalents. Use only correct replacement parts and fasteners. Metric and inch fasteners require appropriate tools to install.

**NOTE:** Right- and left-hand sides are determined by facing in the direction the implement will travel when moving forward.

## **1.2 Serial Number**

Record the serial number, model number, and model year of your cart to help trace the machine in the event that it is stolen. Your dealer also needs these numbers for all warranty claims and for when you order parts.

The cart serial number is found on the serial number plate, which is located on the front of the machine as shown in Figure 1-1.

Record your serial number, model number, and model year in the space provided below.

**Serial Number:**

\_\_\_\_\_

**Model Number:**

\_\_\_\_\_

**Model Year:**

\_\_\_\_\_



Figure 1-1: Serial Number Plate Location

## **2.0 SAFETY**

### **2.1 Recognizing Safety Information in Manual**

Figure 2-1 is the safety-alert symbol. When you see this symbol on your machine or in this manual, be alert to the potential for personal injury.

Follow recommended precautions and safe operating practices.



Figure 2-1: Safety-Alert Symbol

### **2.2 General Safety**

You are responsible for the safe operation and maintenance of your Amity implement. You and anyone else who will operate, maintain, or work around the machine should be familiar with the operating and maintenance procedures and safety information in this manual.

Safety practices protect you and the people around you, so make them a working part of your safety program.

Equipment owners must give operating instructions annually to operators or employees before allowing them to operate the machine, per OSHA regulation 1928.57.

The most important element of safety for this equipment is a safe operator. It is the operator's responsibility to read and follow all safety and operating instructions in the manual. All accidents can be avoided.

A person who has not read and understood all operating and safety instructions is not qualified to operate the machine. An untrained operator exposes himself and bystanders to serious injury or death.

Do not modify the equipment in any way. Unauthorized modification may impair the function or safety, or both, and could alter the life and warranty of the product.

The following list is a set of safety guidelines to adhere to:

1. Read and understand the Operator's Manual and all safety signs before operating, maintaining, or adjusting the machine.
2. Install and properly secure all shields and guards before operating.
3. Have a first-aid kit available and know how to use it.
4. Have a fire extinguisher available and know how to use it.
5. Clear the area of people and remove foreign objects from the machine before starting and operating.
6. Shift to park, disengage PTO, lower machine to ground, relieve hydraulic pressure, stop engine, remove ignition key, and wait for all moving parts to stop before servicing, adjusting, repairing, or disconnecting.

7. Annually review safety guidelines with all operators.
8. Wear suitable ear protection for prolonged exposure to excessive noise.

Think **SAFETY!** Work **SAFELY!**

### **2.3 Maintenance and Operating Safety**

1. Read and understand all information contained in the Operator's Manual regarding maintenance, adjustment, and operation of the machine.
-  2. Shift to park, disengage PTO, lower machine to ground, relieve hydraulic pressure, stop engine, remove ignition key, and wait for all moving parts to stop before servicing, adjusting, repairing, or disconnecting the machine.
3. Keep hands, feet, clothing, and hair away from all moving and/or rotating parts.
4. Ensure that all tractor controls are in neutral before starting.
5. Never wear ill-fitting, baggy, or frayed clothing when working on or around the machine.
6. Make sure that all guards and shields are properly installed and secured before operating the machine.
7. Clear the area of all bystanders, especially children, when carrying out any maintenance or making adjustments on the systems or components.
8. Place stands or blocks under the frame before working beneath the machine.
9. Do not allow riders on the implement or tractor during field operation or transport.
10. Never operate the machine inside a closed building.
11. Stay away from overhead obstructions and power lines during setup and operation. Electrocution can occur without direct contact.

## **2.4 Hydraulic Safety**

1. Always place all tractor hydraulic controls in neutral before dismounting.
2. Make sure that all components in the hydraulic system are kept in good condition and are clean and tight.
3. Replace any worn, cut, abraded, flattened or crimped hoses and metal lines.
4. Do not attempt any makeshift repairs to the hydraulic lines, fittings, or hoses by using tape, clamps, or cements. The hydraulic system operates under extremely high pressure. Such repairs may fail suddenly, creating a hazardous and unsafe condition.
5. Wear proper hand and eye protection when searching for a high-pressure hydraulic leak. Use a piece of wood or cardboard as a backstop instead of hands to isolate and identify a leak.
6. If injured by a concentrated high pressure stream of hydraulic fluid, seek medical attention immediately. Serious infection or toxic reaction can develop from hydraulic fluid piercing the skin's surface.
7. Before applying pressure to the system, make sure all components are tight and that lines, hoses, and couplings are not damaged.
8. On self-contained hydraulic systems, make sure that shut off valves are in open position before engaging PTO.

## **2.5 Transport Safety**

1. Read and understand all information in the Operator's Manual regarding procedures and safety when operating the machine in the field or on the road.
2. Make sure the Slow Moving Vehicle (SMV) emblem and required lights and reflectors are in place, clean, and can be seen clearly by all overtaking and oncoming traffic.
3. Do not allow riders on any part of the machine during either field operation or travel.
4. Attach the machine to the tractor using only a drawbar pin with provisions for a mechanical retainer.
5. Always attach a safety chain.
6. Always use hazard warning flashers when transporting unless prohibited by law.
7. Always move all parts of the machine to transport position when travelling on a road.
8. Stay away from overhead obstructions, such as power lines.
9. For max transport speed on smooth roads, see section 3.3.

## 2.6 Safety Decals

The types of decals on the equipment are shown in the illustration below. Proper safety requires that you familiarize yourself with the various safety decals, the type of warning, and the area, or particular function related to that area, that requires your safety awareness.

**REMEMBER:** If safety decals have been damaged or removed, become illegible, or parts are replaced without decals, then new decals must be applied. New decals are available from your authorized dealer.



PN: 9971013

**Hazard:** Moving Parts

**Avoidance:** Keep shields and doors in place at all times when operating the machine.

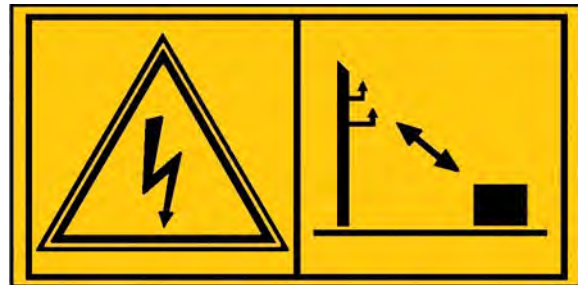

PN: 9971021

**Hazard:** Electrical Shock

**Avoidance:** Stay clear of overhead power lines and other obstructions.



PN: 303265

**Hazard:** Crushing from Above

**Avoidance:** Never crawl or work under machine unless it is properly supported.



PN: 9971011

**Hazard:** Moving Parts

**Avoidance:** Keep hands, feet, hair, and clothing away from moving parts.



PN: 9971015

**Hazard:** Falling off Machine

**Avoidance:** Do not climb on the machine.



PN: 997859

**Hazard:** General Safety Alert

**Avoidance:** Shut off engine and remove key before performing maintenance or repair work.



PN: 303277

**Hazard:** Falling off Machine

**Avoidance:** Do not climb on the machine.



PN: 997861

**Hazard:** General Safety Alert

**Avoidance:** Read and understand the Operator's Manual before operating the machine.

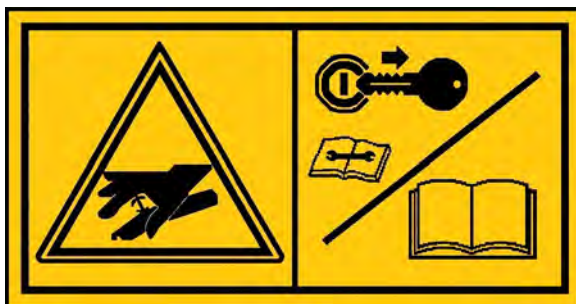

PN: 997867

**Hazard:** High Pressure Fluid

**Avoidance:** Relieve pressure on system before repairing, adjusting, or disconnecting. Wear proper hand and eye protection when searching for leaks. Use wood or cardboard instead of hands. Keep all components in good repair.



PN: 303263

**Hazard:** Getting Limbs or Clothing Stuck in Machine

**Avoidance:** Keep hands, feet, hair, and clothing away from moving parts.

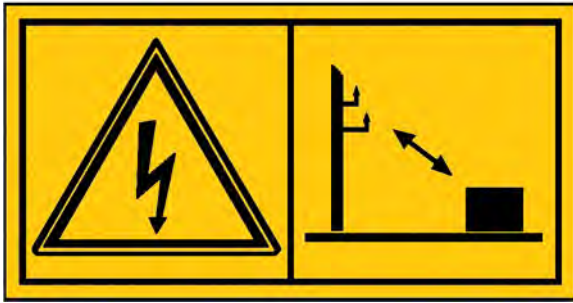

PN: 997863

**Hazard:** Electrical Shock

**Avoidance:** Keep the machine clear of overhead electrical power lines.



PN: 303268

**Hazard:** Rotating Part

**Avoidance:** Keep clothing, yourself, and others clear.



PN: 9971025

**Hazard:** Crushing from Above

**Avoidance:** Stay clear of this area while engine and machine are operating.



PN: 311206

**Hazard:** Whole Body Entanglement

**Avoidance:** Do not remove safety shield while engine is running.



PN: 307165

**Hazard:** Flying Debris

**Avoidance:** Keep top door closed when flails are rotating.



PN: 303267

**Hazard:** Rotating Flails

**Avoidance:** Do not approach machine until flail rotation has stopped.



PN: 311207

**Hazard:** Pinch Point

**Avoidance:** Keep hands clear of any moving parts around the pinch point.



PN: 997841

**Hazard:** Crushing from Moving Parts

**Avoidance:** Stay clear of this area while engine and machine are operating.



PN: 997853

**Hazard:** Negative Tongue Weight

**Avoidance:** Stay clear of the tongue when disconnecting the implement from the tractor. Read the Operator's Manual or safety information and operating instructions before operating the machine.



PN: 997857

**Hazard:** Loss of Machine Control

**Avoidance:** Install the safety chains when attaching the implement to the tractor. Read the Operator's Manual for safety information and operating instructions before

## 3.0 SPECIFICATIONS

### 3.1 Cart Specifications

Table 3-1: Cart Specifications

<b>Weight (Approx.)</b>	38,000 lbs [15,875 kg]
<b>Tank Capacity</b>	35 US Tons [31.8 Metric Tons]
<b>Max Road Travel Speed (Unloaded)</b>	20 mph [32 kmh]
<b>Transport Height</b>	12ft [3.66 m]
<b>Tip Top Height</b>	12.5 ft [3.81 m]
<b>Field Position Height</b>	20.5 ft [6.25 m]
<b>Load Side Height</b>	10.75 ft [3.28 m]
<b>Transport Width</b>	11.4 ft [3.48 m]
<b>Field Position Width</b>	11.4 ft [3.48 m]
<b>Unloading Width</b>	26 ft [7.92 m]
<b>Length</b>	35 ft [10.7 m]

Table 3-2: Track Size

<b>Width (Each)</b>	3 ft [0.9 m]
<b>Length</b>	12.3 ft [3.8 m]
<b>Height</b>	3.4 ft [1m]
<b>Width [Center to Center]</b>	8.3 ft [2.5 m]

**3.1.1 Hydraulic Flow Rates:** Each hydraulic circuit for the cart has a designated flow rate; approximate values for different unloading situations are listed in the table below.

Table 3-3: Hydraulic Flow Rates

	<b>Ground Unload</b>	<b>Short Truck Unload</b>	<b>Tall Truck Unload</b>
<b>Front and Rear Floors</b>	15 GPM [56.8 L/m]	12 GPM [45.4 L/m]	10 GPM [37.9 L/m]
<b>Center Floor and Feed Roller</b>	15 GPM [56.8 L/m]	12 GPM [45.4 L/m]	10 GPM [37.9 L/m]
<b>Elevator</b>	30 GPM [114 L/m]	30 GPM [114 L/m]	30 GPM [114 L/m]
<b>Elevator Fold</b>	5 GPM [18.9 L/m]	-	-
<b>Hydraulic Jack</b>	5 GPM [18.9 L/m]	-	-

**NOTE:** Values listed are a good starting point; however, flow rates should be fine-tuned to allow the smallest flow rate possible while still providing enough power to run the cart efficiently.

### 3.2 Tractor Specifications

Table 3-3: Tractor Specifications

<b>Minimum Horsepower</b>	300 hp [223.7 kW]
<b>PTO Output</b>	1000 RPM
<b>Spline Size</b>	1 $\frac{3}{4}$ " - 20 spline
<b>Minimum Hydraulic Capacity*</b>	40 GPM [151 L/m]
<b>Hydraulic Pressure</b>	2700 PSI [18.6 MPa]
<b>Minimum Number of Remotes</b>	4

\*40 GPM (151 L/min) is the minimum hydraulic capacity however it is recommended to use a tractor with a higher capacity to increase the efficiency especially when unloading into tall trucks.

**Note:** If the tractor in use cannot produce the required hydraulic capabilities there is an optional PTO pump system that can be added. The PTO pump will then be used to drive the elevator hydraulic motors instead of being run by the tractor's hydraulics.

## **4.0 PREPARATION**

### **4.1 Tractor Preparation**

**4.1.1 Three-Point Hitch Position:** Three-point hitches cannot be connected to the hitch when using an Amity beet cart. It must be fully raised or removed.

**NOTE:** Amity recommends removing three-point hitches.



Figure 4-1: Fully Raised Three-Point Hitch

### **4.2 Cart Preparation**

**4.2.1 Elevator Hydraulic Valve Control Box:** The elevator control box must be correctly wired and securely fastened in the tractor cab.



**4.2.2 Shield Placement:** Before starting, be sure to secure the shields in operating position (closed position).



Figure 4-2: Elevator Control Box

**4.2.3 Gearbox Oil Level:** Check all gearbox oil levels before operating. Refer to section 11.0, Lubrication and Maintenance, for oil type and fill level information.

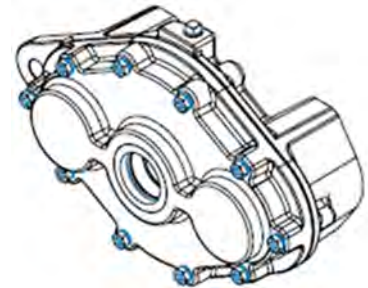

Figure 4-3: Gearbox

**4.2.4 Greasing:** Refer to section 11.0, Lubrication and Maintenance, for grease type and frequency requirements.

**IMPORTANT:** Use only hand held grease guns. Air-powered grease guns can damage your seals. Over greasing may also damage bearing seals. If damage due to over greasing occurs, replace the damaged seals immediately.

## **5.0 ATTACHING AND DETACHING**

### **5.1 Attaching Hydraulic and Electrical Systems**

**!** **CAUTION:** To avoid injury from escaping fluid under pressure, relieve the pressure in the system before disconnecting or connecting hydraulic or other lines. Tighten all connections before applying pressure.

1. Connect all hydraulic lines to tractor as shown in Figure 5-1.
2. Connect the cart warning light harness to the tractor. Make sure the cart warning lights operate with the tractor warning lights and turn signals.
3. Connect the elevator valve control box, and if equipped, the scale monitors to the harness routed into the tractor cab.



Figure 5-1: Attaching Hydraulic Lines

### **5.2 Attaching Cart to Tractor Drawbar**

1. Remove the tractor hitch pin.
2. Adjust the hitch height.
3. Line up the pull plate with the drawbar.
4. Shift to park, shut off the engine, and remove the ignition key before getting out of tractor.
5. Lubricate and reinstall the hitch pin.
- !** 6. Connect the safety chain to the drawbar supporting structure.



Figure 5-2: Attaching Cart to Tractor Drawbar

### 5.3 Using Stands

**CAUTION:** Always use stands when working on, near, or underneath the harvester.

Make sure cart is on level ground and will not roll down any hill or sloped surface.

To raise, use the hydraulic jack remote to supply oil to extend the jack cylinder. Position the jack stand so that the pad lifts on level ground. Ensure all remotes are seated into their ports or completely removed and that there are no leaks in the hydraulic lines or fittings before working near a unit on the jack.

To lower, use the hydraulic jack remote to supply oil to the retract end of the jack cylinder until weight is completely off the jack. Retract the jack stand completely to avoid any potential collision during transport or operation

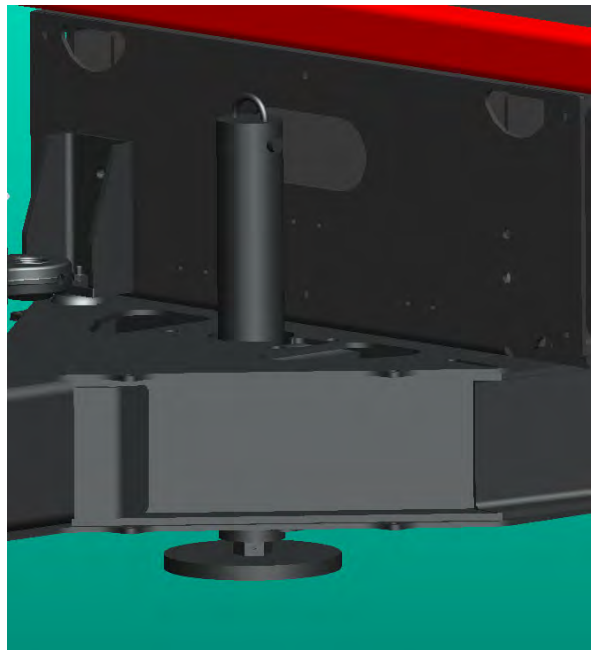

Figure 5-3: Cart Stand

## **6.0 OPERATING THE CART**

### **6.1 Cart Components**

#### **6.1.1 Front and Rear Floors**

The front and rear floors are solid planked floors that use slatted drag chain to pull beats into the center section.



Figure 6-1: Front / Rear Floor

#### **6.1.2 Center Floor**

The center floor changes the direction of beat flow from the front and rear floors and transfers the beat to the feed roller. The center floor also use slatted drag chain.



Figure 6-2: Center Floor

#### **6.1.3 Feed Roller**

The feed roller is an assembly of different sized rubber octagon shaped wheels that spins at a higher rate than the floors with the purpose of feeding beats from the center floor to the elevator.

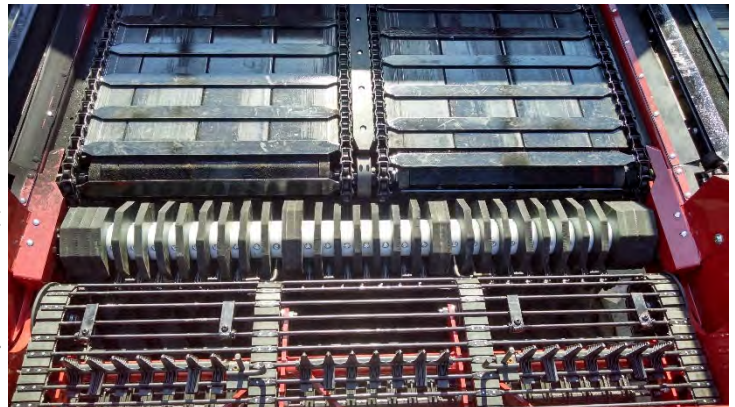

Figure 6-4: Assembled Feed Roller



Figure 6-3: Feed Roller

### 6.1.4 Elevator

The cart elevator is a two part elevator that folds in the middle to transition from transportation position and field position. The elevator uses belted chain with fingers to grab the beets and pull them up the elevator to unload the beets at the desired height and location.



Figure 6-5: Elevator

### Terminology:

Transportation Position-refers to when the elevator is folded to fit inside the tank walls as shown in Figure 6-6.

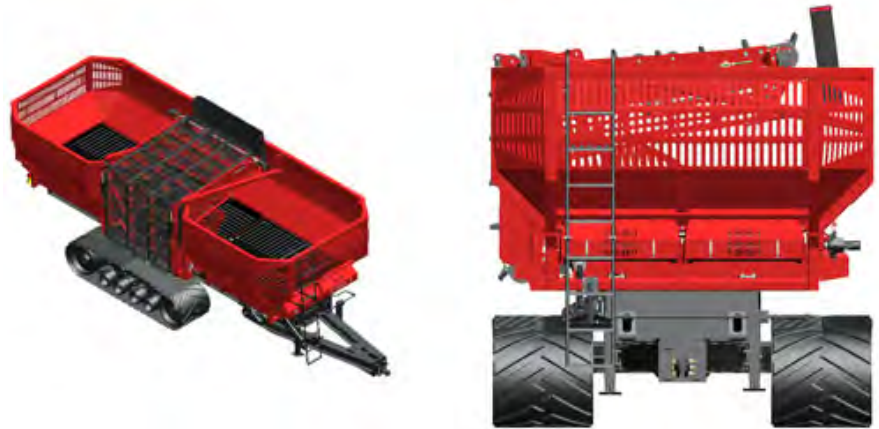

Figure 6-6: Transportation Position

Field Position-refers to when the elevator is in a vertical position as shown in Figure 6-7.



Figure 6-7: Field Position

### 6.1.5 Beet Deflector

The beet deflector is the adjustable rubber back stop at the end of the elevator and is used to stop the beets from overshooting allowing the elevator to run at the maximum speed.



Figure 6-8: Beet Deflector

### 6.1.6 Stands

The cart's stands are shown in Figure 6-9 and is used keep the cart level when it's not connect to the tractor and adjust the height of the hitch for attaching and detaching.

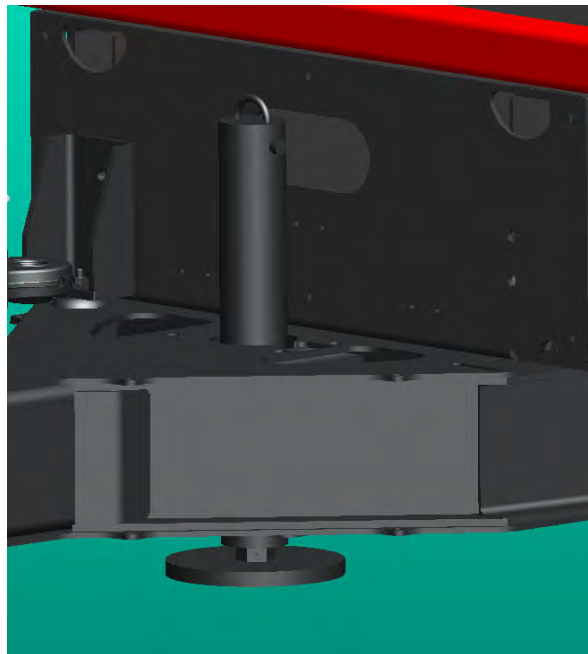

Figure 6-9: Stands

## 6.2 Field Start Up

### 6.2.1 Regular Field Start Up

After entering a field the cart elevator needs to be transitioned from transportation position to field position before being loaded with beets. To make this transition follow the following steps.



1. Ensure that you, bystanders, and all objects are clear of the cart before starting.
2. Pressurize the large elevator cylinders and unfold the entire elevator until the cylinders reach their maximum.
3. Flip and **Hold** the elevator hydraulic valve control switch to transfer the flow of hydraulic fluid from the large cylinders to the small middle fold cylinders.
4. Unfold the upper section of the boom until it becomes aligned with the lower section of the boom
5. Exit the tractor and insert the elevator locking pins to ensure the upper section cannot unintentionally collapse. (There are 2 pins, one on each side) If holes do not line up refer to Section 7.2.2 for adjustment.
6. Fold the entire boom until it hits the stops on the center section and the elevator is standing straight up. Refer to Section 7.2.4 for stop adjustments.

### 6.2.2 Cold Start Up – For Temperatures Near Freezing

If temperatures are near freezing be sure to follow these additional steps for best results.

1. Clean mud from elevator and floors to prevent possible damage upon start up.
2. Run elevator and floors while cart is empty to warm up hydraulic oil so maximum performance is obtained and hydraulic motors do not stall.



**IMPORTANT:** Never fold or unfold the upper section of the elevator when the elevator is standing straight up. Always extend the large hydraulic cylinders as far as possible before transferring flow to the smaller cylinders.



**IMPORTANT:** Upon annual first use raise and lower each section of the elevator multiple times to ensure the cylinders and lines are completely filled with hydraulic fluid and air free.

 **CAUTION:** Never unfold or operate the cart with the elevator extend near overhead obstruction or overhead power lines.

### 6.3 Field Operating Speed

The cart operating speed when being loaded in depend on the harvester speed; typical speeds are 3 -5 mph (4.8-8 kmh).

The maximum speed of the cart is 20 mph (32 kmh).

### 6.4 Turning Radius

Turning the cart requires a wide area. A minimum turning radius of three times the length of the tractor plus the length of the cart is recommended (3x Tractor + 35 feet (10.67 meters)). When executing a sharp turn it is import to watch to make sure the tractor tire to not come in contact with any part of the cart.

**IMPORTANT:** Failure to provide a sufficient turning radius for the tractor and cart may lead to damage of the cart, the tracks, or the tractor.

### 6.5 Unloading Into Trucks

To unload into a truck follow the following instruction.

-  1. Ensure that you, bystanders, and all objects are clear of the cart before starting this process and remain clear throughout the process.
2. Pull up parallel to the truck and align the cart the correct distance from the side of the truck which will be dependent on the height of the truck and the elevation of the elevator.
3. Position the cart front to back so that the elevator drop zone is entirely inside the truck box.
4. Lower the elevator until it resides approximately 1 foot higher than the truck box. The beet deflector should be centered between the truck box side walls.
5. Start the elevator hydraulic motor using the corresponding remote and leave it detent.
6. Once the flow of beets out the end of the elevator starts to diminish start the center floor using its corresponding remote and leave it in detent.
7. Once the pile of beets in the truck box reaches the top of the box walls slowly start to pull forward or backward, depending which side of the truck you are one, building the pile to the same height as you go.

8. When the flow of beets out the end of the elevator starts diminish again start the front and rear floors using its corresponding remote and leave it detent.
9. When the elevator reaches the end of the truck box stop moving forward finish building the pile to the correct height and then stop the cart in the following order.
  - a) Stop the front and rear floors
  - b) Stop the center section
  - c) Stop the elevator

**IMPORTANT:** Always follow the steps in this order when stopping the cart hydraulic or beet damage could occur

10. If beets still remain in the cart tank find the next truck and repeat steps 3 through 9. If the tank is empty raise the elevator to field position and return to the field to be refilled by a harvester.

## 6.6 Unloading Onto the Ground

To unload onto the ground follow the following instruction.

-  1. Ensure that you, bystanders, and all objects are clear of the cart before starting this process and remain clear throughout the process.
2. Lower the elevator as far as possible. This will help achieve the fastest unloading speed.
3. Pull up parallel to the unloading zone.
4. Start the elevator hydraulic motor using the corresponding remote and leave it detent.
5. Once the flow of beets out the end of the elevator starts to diminish start the center floor using its corresponding remote and leave it in detent.
6. When the flow of beets out the end of the elevator starts diminish again start the front and rear floors using its corresponding remote and leave it in detent.
7. As the pile grows taller the elevator will need to be raised so the elevator tip remains at least 1 foot above the pile at all times.
8. Once the pile has reached the desired height slowly pull forward building the pile to the same height along the way.
9. When the cart becomes empty stop all the hydraulic motors (front, rear, center, and elevator) and fold the boom back into field position.

## 6.7 Break- in Period

After an initial 5 hours of normal field operation, check to make sure all the major components are adjusted correctly and working properly. Refer to Section 11 for more details.

## 6.8 Field Cleaning

The cart will collect mud at different rates during operation depending on soil conditions. It is important to clean the machine every two hours or more often if the conditions demand.

**IMPORTANT:** If left unclean, mud will clog the machine and cause imminent damage. Frequently clean the machine to avoid damage, especially in temperatures near freezing.

## 6.9 Field Shutdown

Before exiting a field the elevator needs to be returned to its transportation position. To make this transition follow the following steps.

- 
1. Ensure that you, bystanders, and all objects are clear of the cart before starting.
  2. Unload any beets that remain within the cart.
  3. Lower the elevator to the lowest position possible.
  4. Exit the tractor and remove the elevator locking pins. (There are 2 pins, one on each side)
  5. Flip and **Hold** the elevator hydraulic value control switch to transfer the flow of hydraulic fluid from the large cylinders to the small middle fold cylinders.
  6. Slowly raise the upper section of the elevator until it hits the stops on the lower section.
  7. Release the elevator hydraulic value control switch to transfer the flow back to the large cylinders.
  8. Slowly raise the entire elevator until it hits the stop on the center section and the elevator is fully folded into the tank. Refer to Section 7 for stop adjustments.

**IMPORTANT:** Never fold or unfold the upper section of the elevator when the elevator is standing straight up. Always extend the large hydraulic cylinders as far as possible before transferring flow to the smaller cylinders.

- 
- CAUTION:** Never fold or operate the cart with the elevator extend near overhead obstruction or overhead power lines.

## 7.0 ADJUSTMENTS

**!** **IMPORTANT:** Before making any adjustments, shift to park, relieve hydraulic pressure, stop the engine, remove the ignition key, and wait for all moving parts to stop before dismounting.

### 7.1 Floor Chain

All three floors, front, rear, and center, use slated drag chains. Over time as the cart is used the chain will elongate due to wear which will cause excess slack in the chain. To prolong the life of the chain and sprocket this slack will need to be removed by tensioning the chain.

Figure 7-1 shows the correct slack wanted during use. Dimension (A) is measured from the bottom of the slacked chain to the underside of the floor panels off the side of the second to end floor joist, on the side facing the adjustment rod. When the machine is not running and at a standstill Dimension (A) should measure 8.75 inches (22.23 cm). A quick reference guide can be seen in Figure 7-1b, if the chain is visible in the hourglass cutout then chain tension is within tolerance. For exact tension, however, refer to previously stated dimension (A).

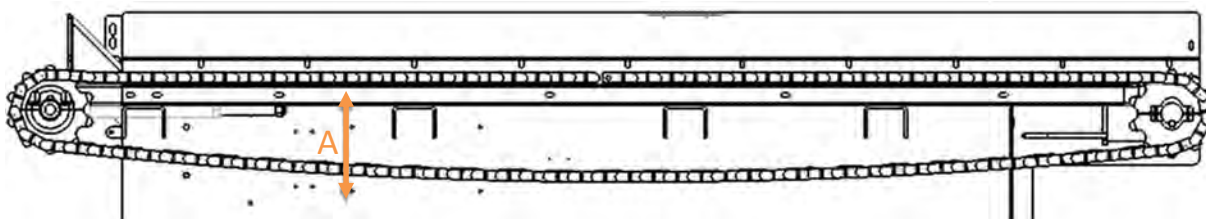

Figure 7-1a: Sectioned Side View of Floor Chain

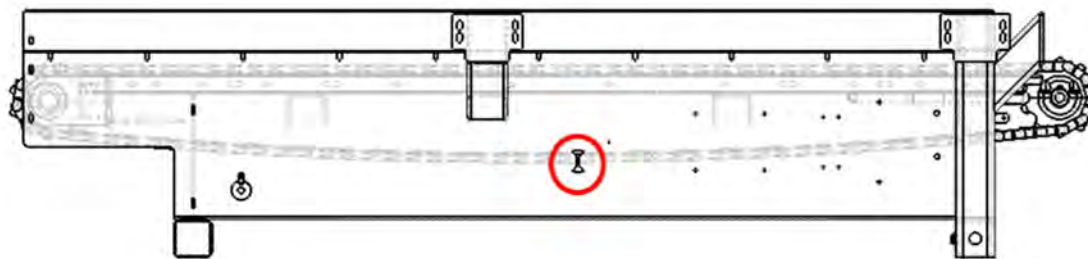

Figure 7-1b: Floor with Hourglass Cutout Visible

If the slack does not match Dimension A (Figure 7-1a) the chain needs to be tensioned. To remove a small amount of excess slack follow the following procedure.

1. Under the floors at the end there is a tensioning system that uses two,  $\frac{3}{4}$ " adjustment rods (A) as show in Figure 7-2. To start tensioning loosen the hex nuts (B).
2. Drive the adjustment rods (A) in small amounts at a time while measuring the slack until it reaches the preferred level.

**NOTE:** There are two adjustment rods for every section of chain and these rods need to be adjusted to the same tension throughout the process.

If the adjustment rod reaches the end of its threads a link in both the chains will need to be removed.

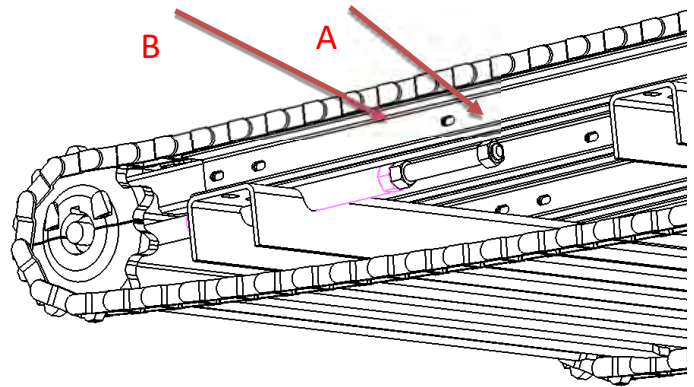

Figure 7-2: Sectioned View of the Floor Chains with Adjustment Rods

## 7.2 Elevator

### 7.2.1 Belted Chain

A quick reference guide to aid in proper chain tensioning can be found on the motor mounts as shown in Figure 7-3a. All the arrows on the tension guides should be set to 5" when the belt is installed. To ensure proper belt tension, use the detailed instructions in the previous paragraph.

As with the floor chain, the belted chain on the elevator needs to be correctly tensioned for smooth operation and prolonged life. To correctly tension the belt, position the elevator in the unloading position, as it would be in the field, and measure the distance over 20 pitches of the belting on the cam side of the belt (not on top of the rods). The belt should be tensioned to 1001mm over 20 pitches with the max being 1002mm.

**NOTE:** Ensure all three bearings are in alignment. Misalignment can result in damage or premature wear.

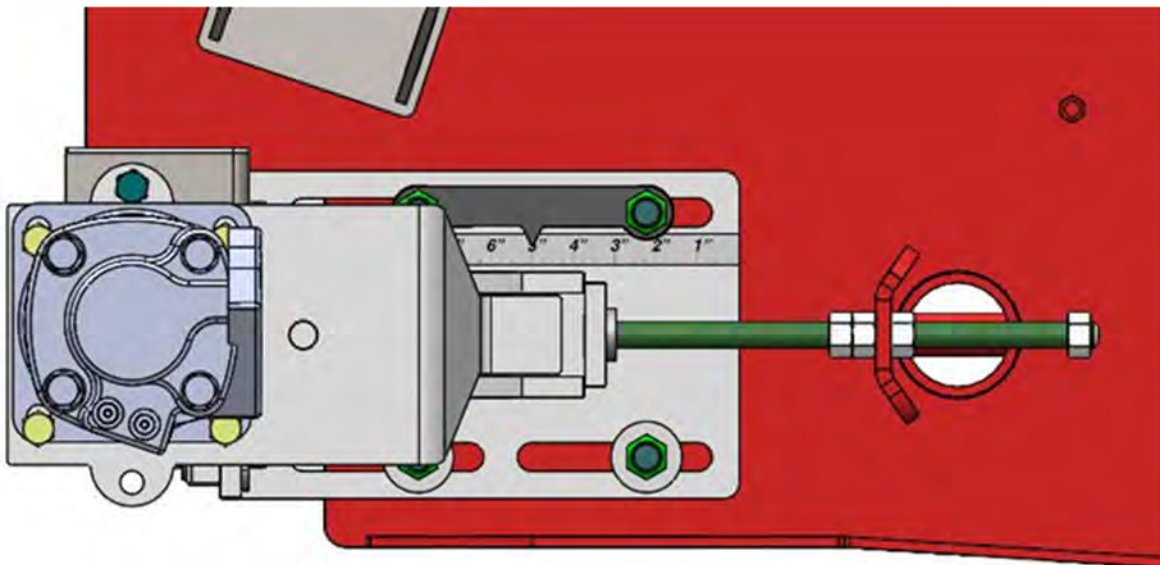

Figure 7-3a: Elevator Chain Tensioning

1. Loosen the four ½” nuts (C) on the slide plate on each side of the elevator.
2. Loosen the four ½” nut and bolts (C2) on the middle support.
3. Loosen the single 5/8” nuts (E2) on the adjustment rods.
4. Drive the adjustment rods (D) in while using a wrench to hold the two 5/8” nut (E1) on motor side. Drive the rod in with small increments making sure to make the same adjustments on either side of the elevator and in the middle.

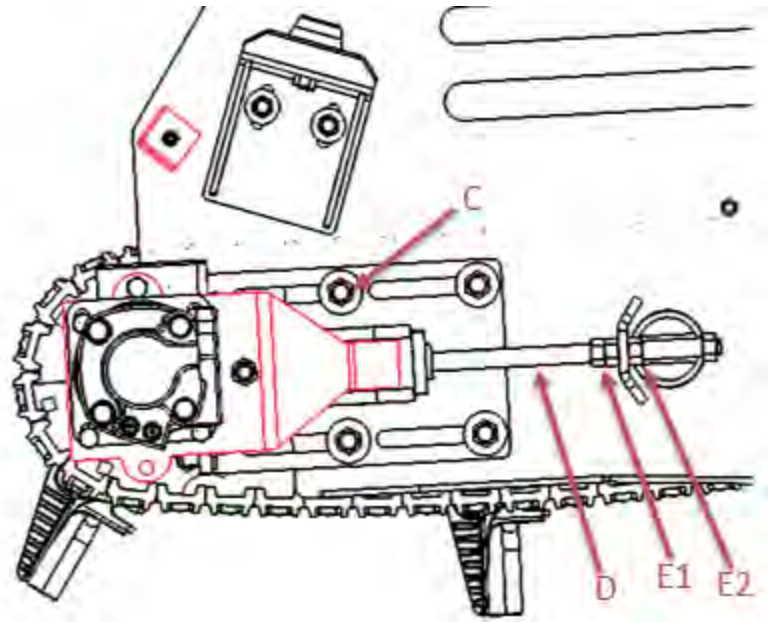

Figure 7-3b: Elevator Chain Tensioning

5. Retighten the four ½” nuts (C) on the slide plates on each side of the elevator and the four nuts and bolts on the middle support.
6. Retighten all the 5/8” nuts on the adjustment rods.

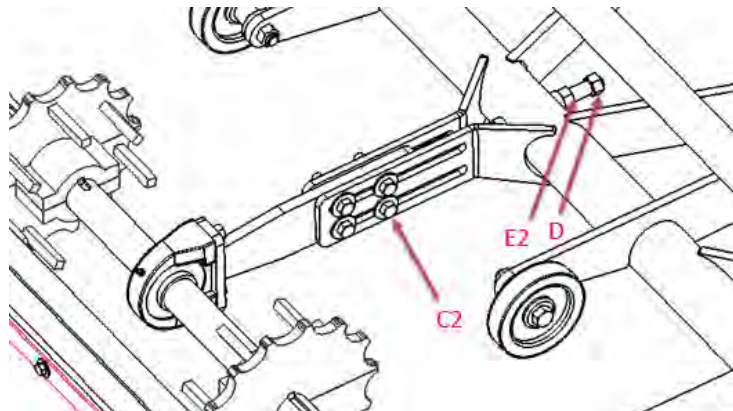

Figure 7-4: Elevator Drive Shaft Middle Support

### 7.2.2 Tension System

The tension system is mounted on the top of the elevators and is used to tension the belted chain when folded for transportation and to take pressure off the short hydraulic cylinders when folded out. The tension system needs to be correctly adjusted so the elevator locking pin holes line up. To line up the holes follow these steps.

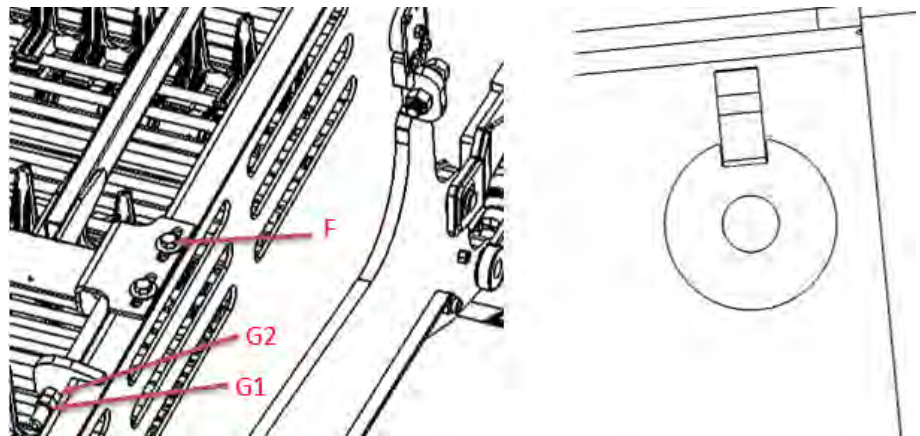

Figure 7-5: Tension System and Hole Line Up

1. Loosen four ½” nuts and bolts (F), two on each side of the elevator and loosen the end 5/8” nuts (G1) on both sides of the elevator.
2. Use the second 5/8” nut(G2) to line up the holes as shown in Figure 7-5 by either tightening the nut to draw the upper section of the elevator up or loosen to drop it down.
3. Once the holes line up retighten the ½” and 5/8” nuts to lock the tension system into place.

### 7.2.3 Beet Deflector

The beet deflector can be adjusted to provide more accurate beet placement. The adjustment of the deflector will vary depending unload height and speed. As the elevator decreases in unload height the deflector should be adjusted closer to the elevator. Vis-versa as the elevator increases in unload height the deflector needs to be adjusted outwards to provide clearance.

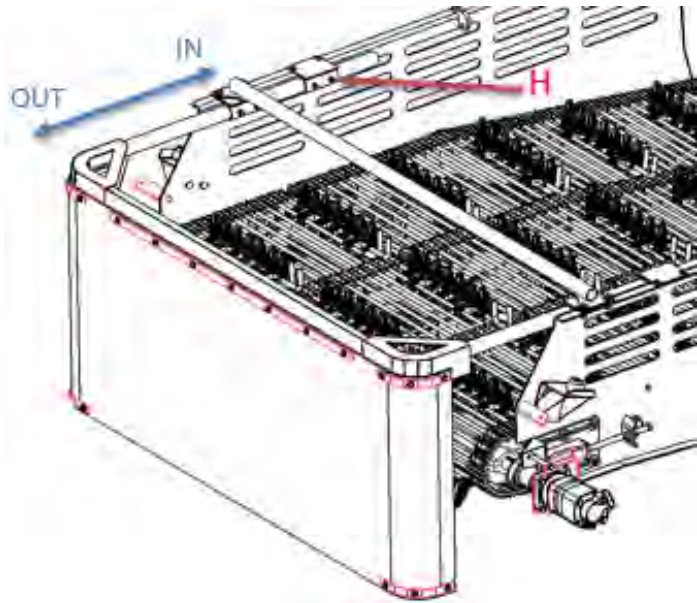

Figure 7-6: Beet Deflector Adjustment

To adjust the deflector follow these steps:

1. Loosen eight 3/8” bolts (H), four on each side of the elevator.
2. Slide the deflector to the desired position (Be sure to adjust both sides of the deflector evenly).
3. Retighten the 3/8” bolts (H).

### 7.2.4 Stop Bolts

There are stop bolts on the elevator that are used to stop folding before reaching the end of the hydraulic cylinder range. The purpose of these stops is to prolong the life of the hydraulic cylinders and to prevent unintended contact between moving parts. Figure 7-7 shows the stop bolts on one side of the elevator. Stop Bolt “B” is the middle fold stop and is factory set at a distance of  $1 \frac{11}{16}$ ” (42.86 mm) from the bolt head to the plate. To make any further adjustments loosen the nuts, adjust the bolts, and then retighten the nuts.

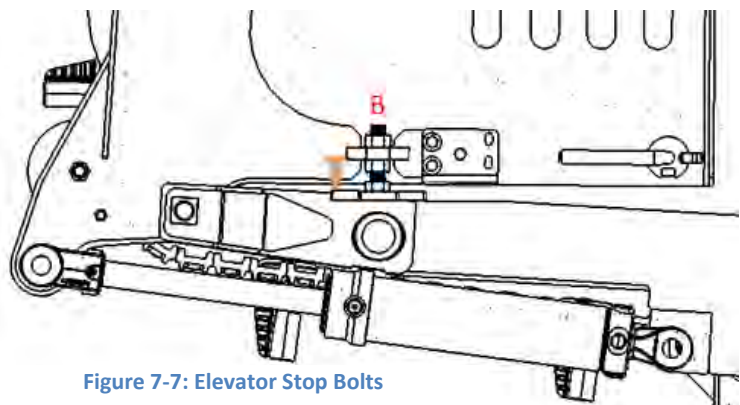

Figure 7-7: Elevator Stop Bolts

### 7.2.5 Plastic Puck

There is a plastic puck (I) that sits inside a hole on the upper section of the elevator which has pressure applied to it via a 3/8" Bolt (J) to create a gap between the walls of the upper and lower section. The purpose of this plastic puck is for it to slide up and down the side of the lower section and prevent contact of the metal side walls of the elevator.

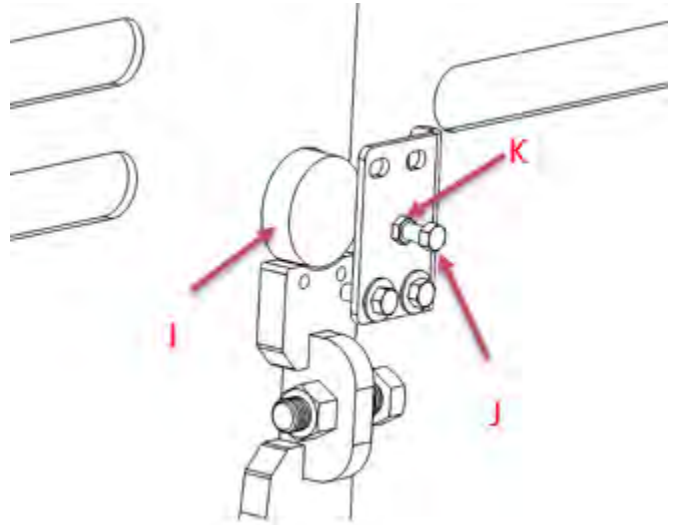

Figure 7-8: Plastic Puck

As this plastic puck is slid up and down as you fold in and out the upper section of the elevator it will cause the plastic to wear. This wear needs to be adjusted for to ensure the metal side walls don't come into contact with each other.

To adjust the plastic puck follow these steps.

1. Loose the Jam Nut (K).
2. Drive the 3/8" Bolt (J) in until there is a 0.125 Inch (0.3175 cm) gap between the side walls
3. Retighten the Jam Nut (K)

### 7.2.6 Feed Roller

The gearbox weldment can be positioned properly by following the dimension displayed (9.375") in Figure 7-9.

For optimum performance and prolonged life of the feed roller:

1. The fingers on the elevator chain must align between each of the sections of the roller.
2. The roller must never come in contact with the floor chain.

As shown in Figure 7-10, the back side of the bearing to the vertical tube in the center section should be around 8".

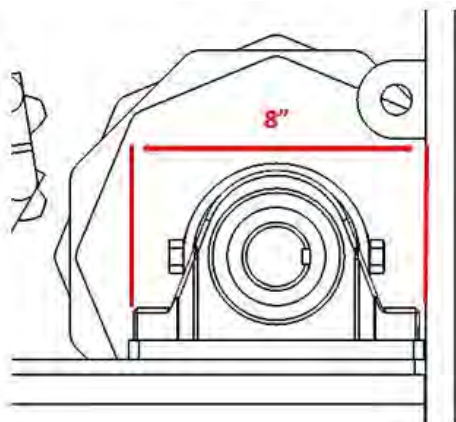

Figure 7-10: Feed Roller

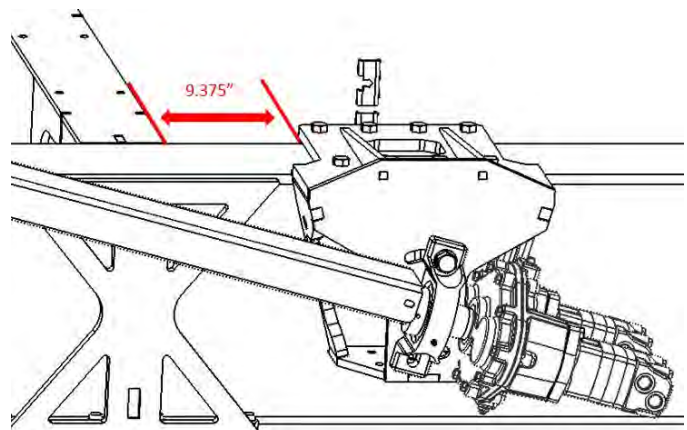

Figure 7-9: Gearbox Weldment

## 7.3 Floors

### 7.3.1 Floor Shaft

It is important to have proper floor shaft alignment for ideal performance of the gearbox that is mounted on the shaft. Referring to Figure 7-11a, there is to be a distance of 10.50" between the end of the shaft (A) and the outside wall of the floor (B).

On the opposite side of the shaft there is to be a spacing of 0.25" between the shaft end (C) and the sprocket (D). This is depicted in Figure 7-11b.

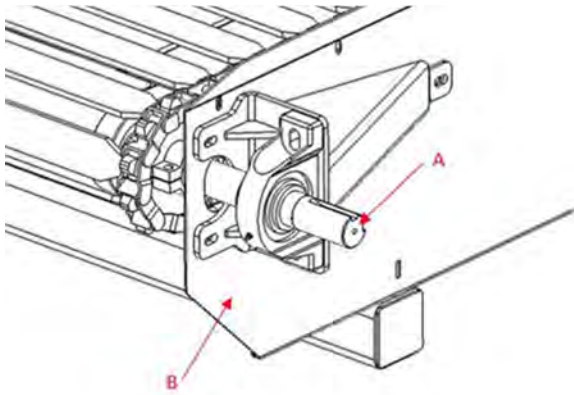

Figure 7-11a: Floor Shaft

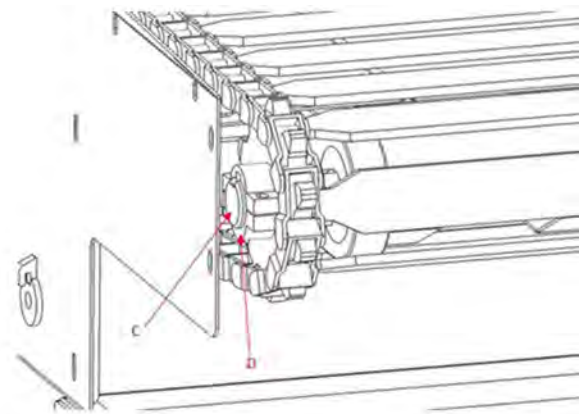

Figure 7-11b: Floor Shaft

### 7.3.2 Floor Rubber Guards

Ensure that the flat plates of the floor chain are .25" from the floor rubber guards at all times. This space allows for proper floor chain function. Figure 7-12 displays the location of this dimension.

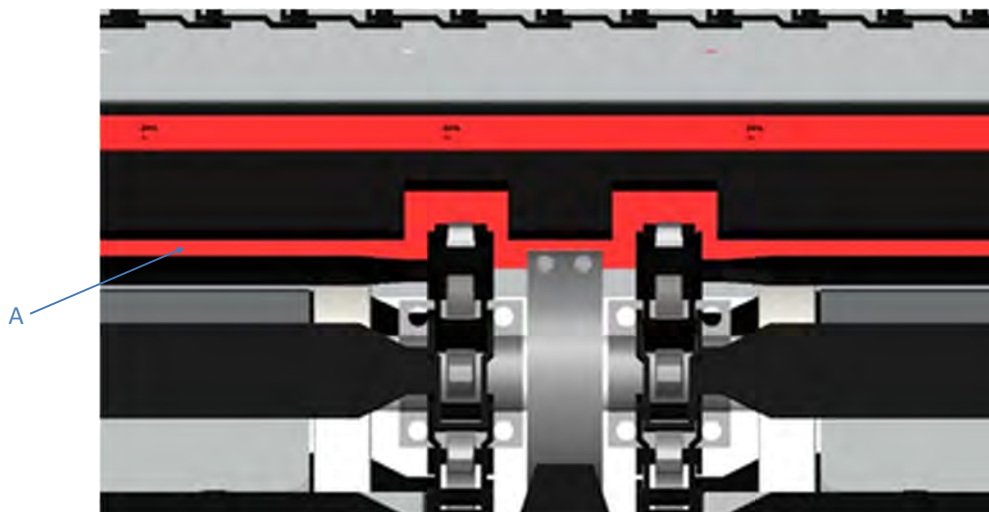



Figure 7-12: Floor Rubber Guard

## 8.0 TRANSPORTATION

### 8.1 Warning Lights

 **CAUTION:** Prevent collisions between other road users, slow moving tractors with attachments or towed equipment, and self-propelled machines on public roads. Frequently check for traffic from the rear, especially in turns, and use turn signal lights or hand signals.

Use headlights, flashing warning lights, and turn signals day and night. Follow local regulations for equipment and marking. Keep lighting and marking visible and in good working order. Replace or repair lighting and marking that has been damaged or lost.

### 8.2 Preparing for Transport

1. Run the machine until it is clear of beets and the tank is empty.
2. Clean all soil and debris off the machine.
3. Fold in the elevator. Refer to Section 6.19.
4. Make sure all safety decals and lights are clean and visible and all tail lights and turn signals function properly.

 **CAUTION:** Always use warning lights when transporting. Braking distance is greatly increased when towing a cart.

**NOTE:** See section 3.3 for maximum transport speeds.

 **CAUTION:** Be aware of overhead obstructions.

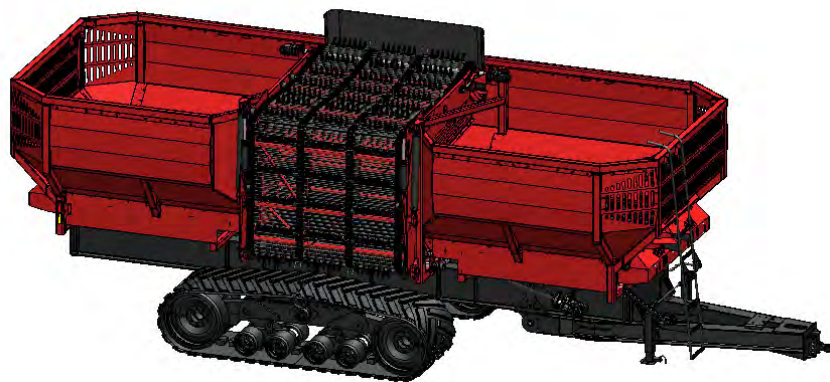

Figure 8-1: Transportation Position

## **9.0 CLEANING**

Cleaning is an important part of cart maintenance. The entire cart should be annually clean at the end of the season to remove dirt and debris. Dirt and debris will attract moisture which will cause rust to form. The rest of this section illustrates a few points where mud will routinely build up and need to be cleaned.

### **9.1 Elevator Drive Sprocket**

The elevator drive sprockets will become packed with mud and should be cleaned routinely.

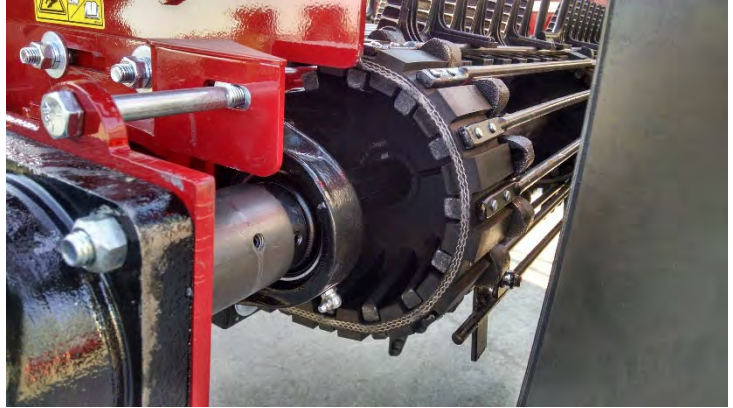

Figure 9-1: Elevator Drive Sprocket

### **9.2 Center/Feed Roller Drive Area**

On both sides of the elevator, under the floors, debris will collect around the feed roller bearings, drive coupler, and the U-joint. This debris needs to be frequently cleaned out to prolong the life of those components.



Figure 9-2: Feed Roller and Center Floor Drive Shafts

### **9.3 Floor Chain**

As the floor chain is dragged over the floor, mud can become wedged between the two. If too much mud collects it will cause the slats to raise off the floor and/or bow up in the middle which will cause an increase in needed torque to start the floor chains.

**!** **IMPORTANT:** It is also very important to routinely clean off any safety decals that become unreadable.

## **10.0 STORAGE**

### **10.1 End of Season**

1. Thoroughly clean the cart inside and out. Debris and dirt will draw moisture and cause rust.
2. Inspect the cart for any damaged or worn components; repair or replace as required.
3. Touch up paint on all parts from which paint has been worn to prevent rusting.
4. Clean all chains by washing with diesel fuel. Dry well and lubricate (see Lubrication and Maintenance, section 11.0).
5. Fold in the elevator.
6. Move the cart to a level, dry, and clean area.
7. Put blocking material under the stands to prevent sinking.

### **10.2 Beginning of Season**

1. Attach the cart to the tractor (see section 5.0).
2. Remove all support blocks from the stands.
3. Lubricate the entire machine (see Lubrication and Maintenance, section 11.0). This will force any collected moisture out of the bearings. Replace the gearbox oil (see Lubrication and Maintenance, section 11.0).
4. Run the cart to ensure proper function.
5. Tighten all loose components including guards and shields.
6. Review the operator's manual prior to operation.

**IMPORTANT:** All components that are damaged or worn must be repaired or replaced before operating the cart (see parts book for part numbers).

## **11.0 LUBRICATION AND MAINTENANCE**

### **11.1 General Maintenance Information**

Perform each lubrication and service illustrated in this section at the beginning and end of each season.

**IMPORTANT:** The period for recommended lubrication and maintenance is based on normal conditions. Severe or unusual conditions may require more frequent lubrication or oil changes.

**IMPORTANT:** The items listed separately from the lubrication chart and the servicing interval pages are of extra importance. These items must be well maintained and checked routinely to maximize their lifespan.

**11.1.1 Grease:** SAE multipurpose high temperature/extreme pressure grease with less than 1% molybdenum disulfide grease should be used.

Clean grease fittings before using a grease gun. Replace any lost or broken fittings immediately. If a new fitting fails to take grease, remove it and check for failure of adjoining parts.

### **11.2 U Joints**

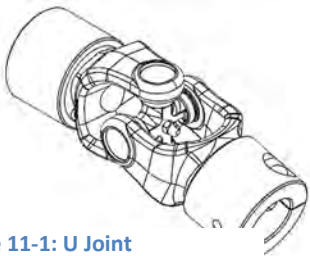

Figure 11-1: U Joint

**IMPORTANT:** On needle bearings, use of grease with more than 1% molybdenum disulfide content may lead to premature U joint failure.

### **11.3 Floor Drag Chain**

The floor chains work in an aggressive environment and needs to be well serviced to maximize its life span. To prolong the life the chain should be regularly cleaned when in use, frequency will depend on the environmental conditions. At the end of the season the chain should be thoroughly cleaned and then well lubricated. At the beginning of the each season the chain should be again well lubricated before its 1<sup>st</sup> use.

The chain will also need to remain properly tensioned when in use and should be routinely monitored. See Section 7 for adjustments if necessary.

## 11.4 Gearbox Oil Level

Gearbox oil levels should be checked routinely and filled to line (A) or 1 Quart (0.95 Liters) as shown in Figure 11-2.

Side plugs (B) can be found on all gearboxes and can be used to measure the correct fill level.

When gearboxes are filled with the proper amount of oil, the level should be just below the threads of side plug (B). Excess oil can be drained from the gearbox using side plug (B).

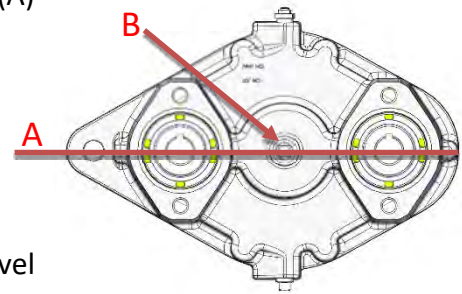

Figure 11-2: Gearbox Oil Level

The oil in the gearbox should be drain and replaced after the first 12 hours of use, then be changed on an annual schedule.

## 11.5 Breather Cleaning

The breather must be able to vent atmospheric conditions during heating and cooling cycles of operation. If it cannot vent, oil will seep out seals and run low. Prolonged operation with low oil levels will damage the internal components. To clean the breather:

1. Remove breather (C).
2. Stop up the breather opening using a plastic plug or a clean rag to prevent contaminants from entering the gearbox.
3. Soak the breather in solvent for one hour.
4. Use a pointed instrument or wire to remove any residue from breather passages.
5. Blow out the breather with high pressure air.
6. Blow through the breather to ensure the passages are clear.
7. Reinstall and tighten breather (C) in the gearbox.

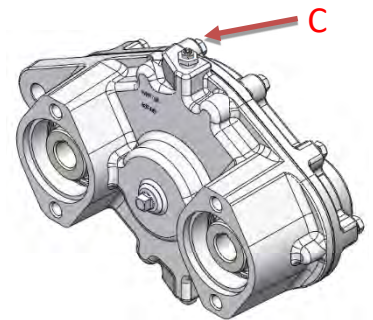

Figure 11-3: Gearbox Breather

## 11.6 Servicing Intervals

### Before 1<sup>st</sup> Use:

1. Check floor and elevator chain for correct tensioning
2. Check all gearbox oil levels
3. Grease Hitch

### 12 Hours\*:

1. Grease hitch and bearings
2. Change oil in gearboxes (after Initial 12 hours only)
5. Check belted elevator chain splices

### 24 Hours\*:

1. Grease U-Joint
2. Check wear on elevator bogey wheel bearings, and replace as necessary
3. Check floor chain tension and wear; check sprockets for proper tension and alignment.  
Adjust as required.
4. Lubricate floor drag chains.

### 250 Hours\* or Annually:

1. Grease all bearings
3. Change oil in gearboxes, rinse gearbox when oil is replaced.
4. Clean gearbox breathers.
3. Check wear on elevator bogey wheel bearings, and replace as necessary.
5. Lubricate floor drag chains.

\*These hours are working hours not field hours, meaning only unloading time is counted

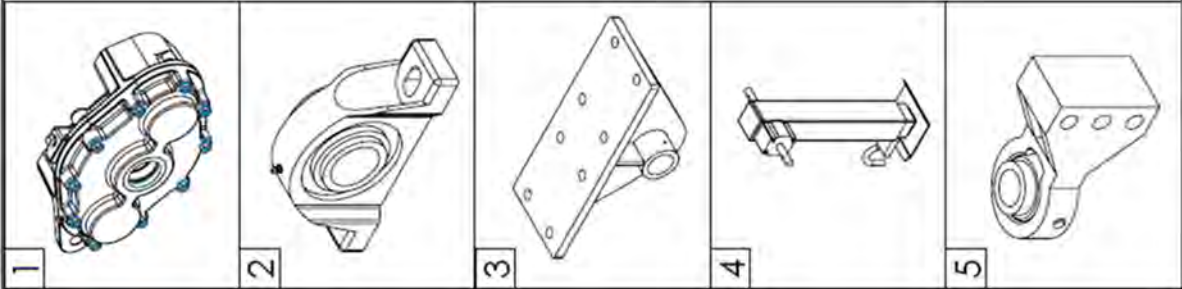
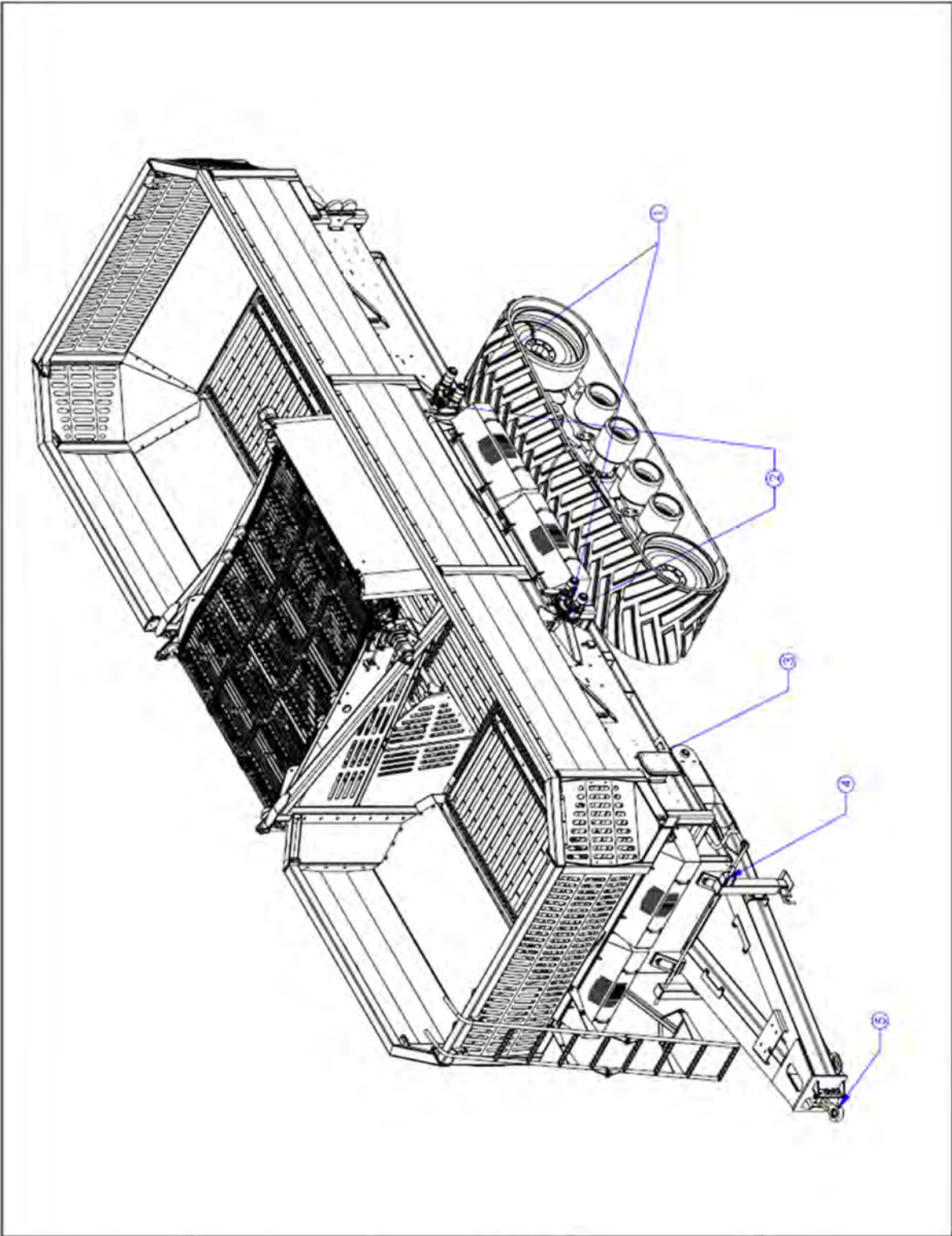

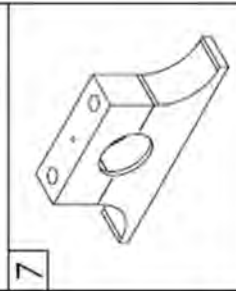
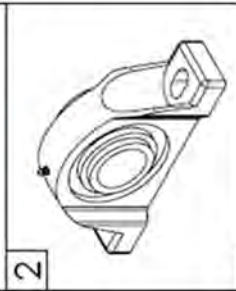
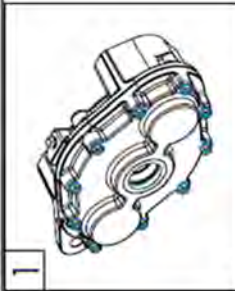
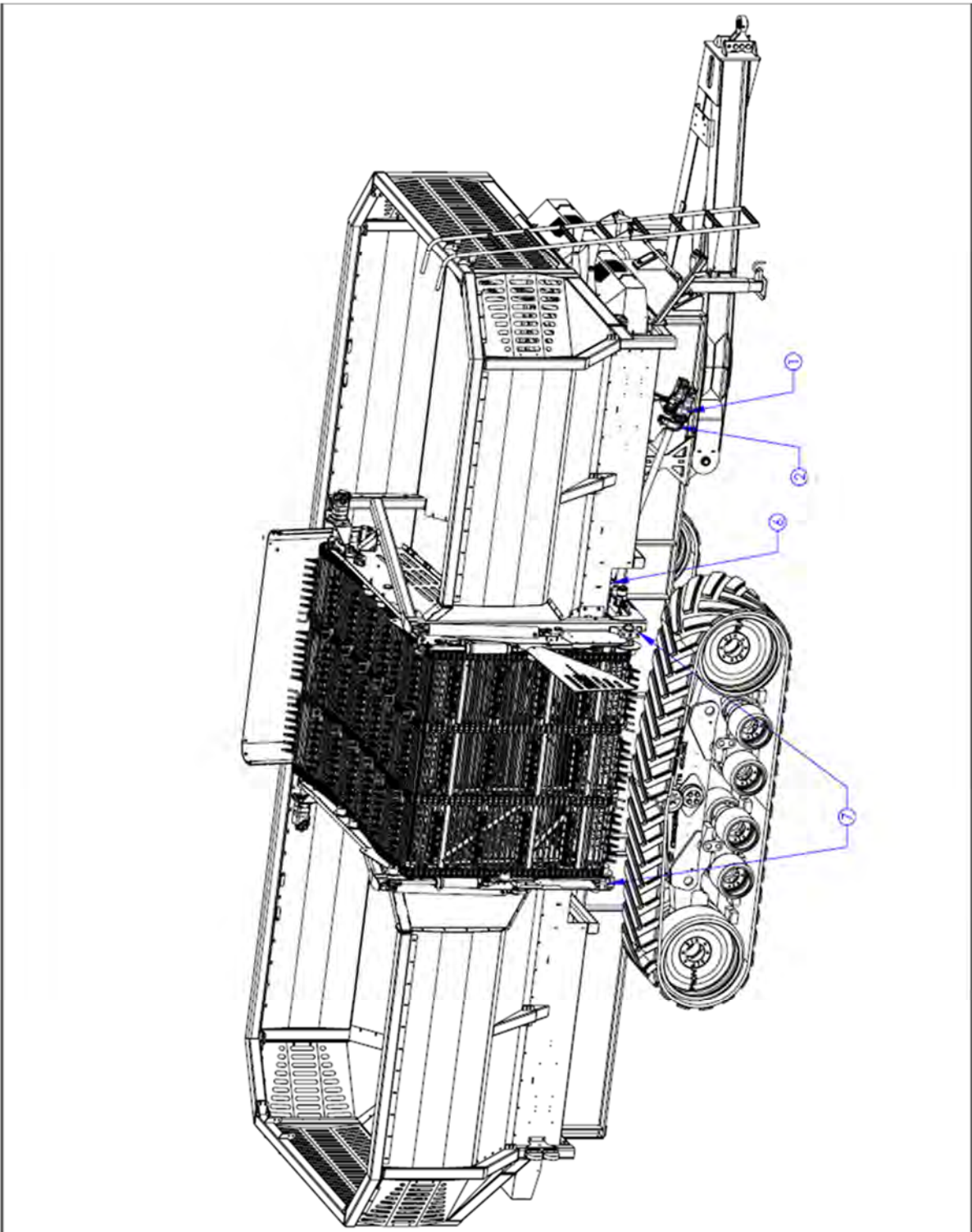

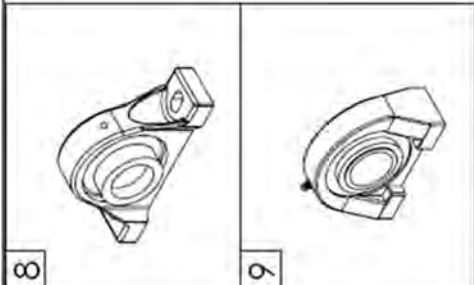
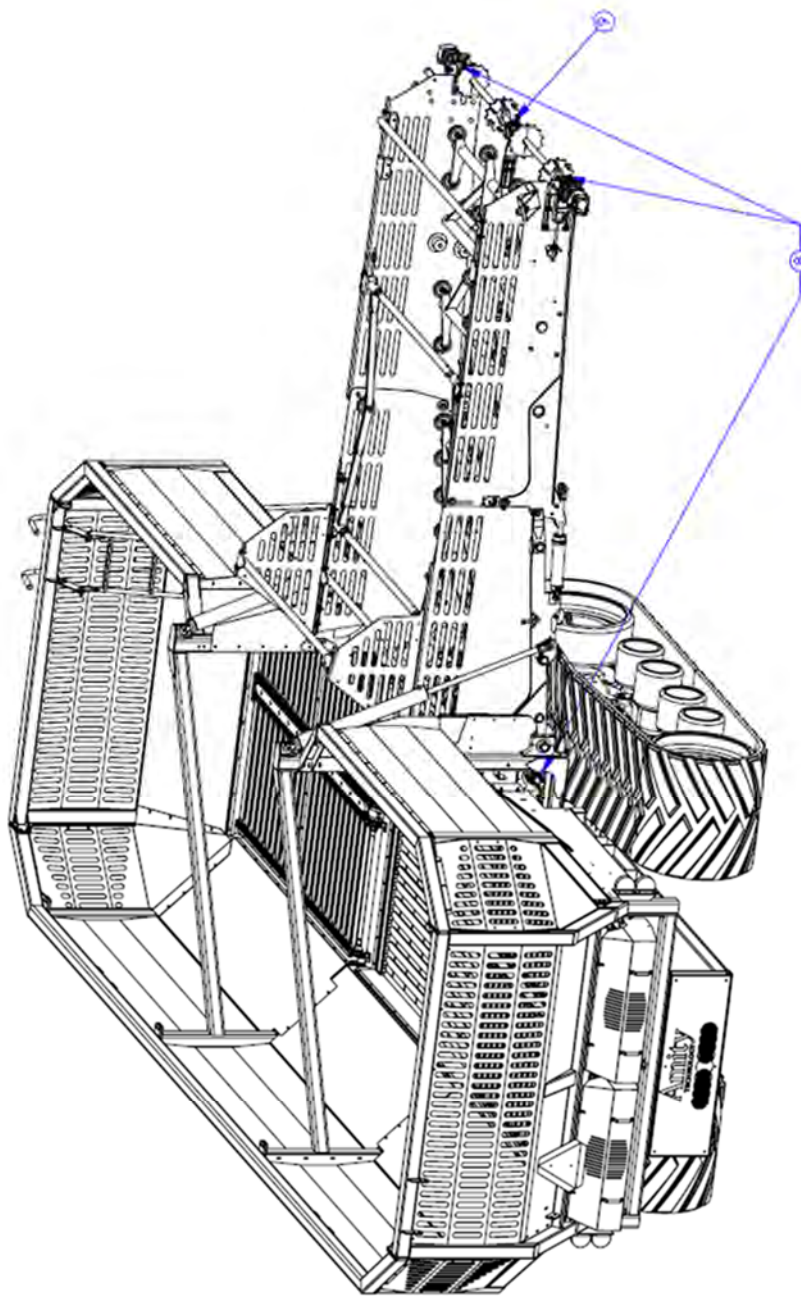

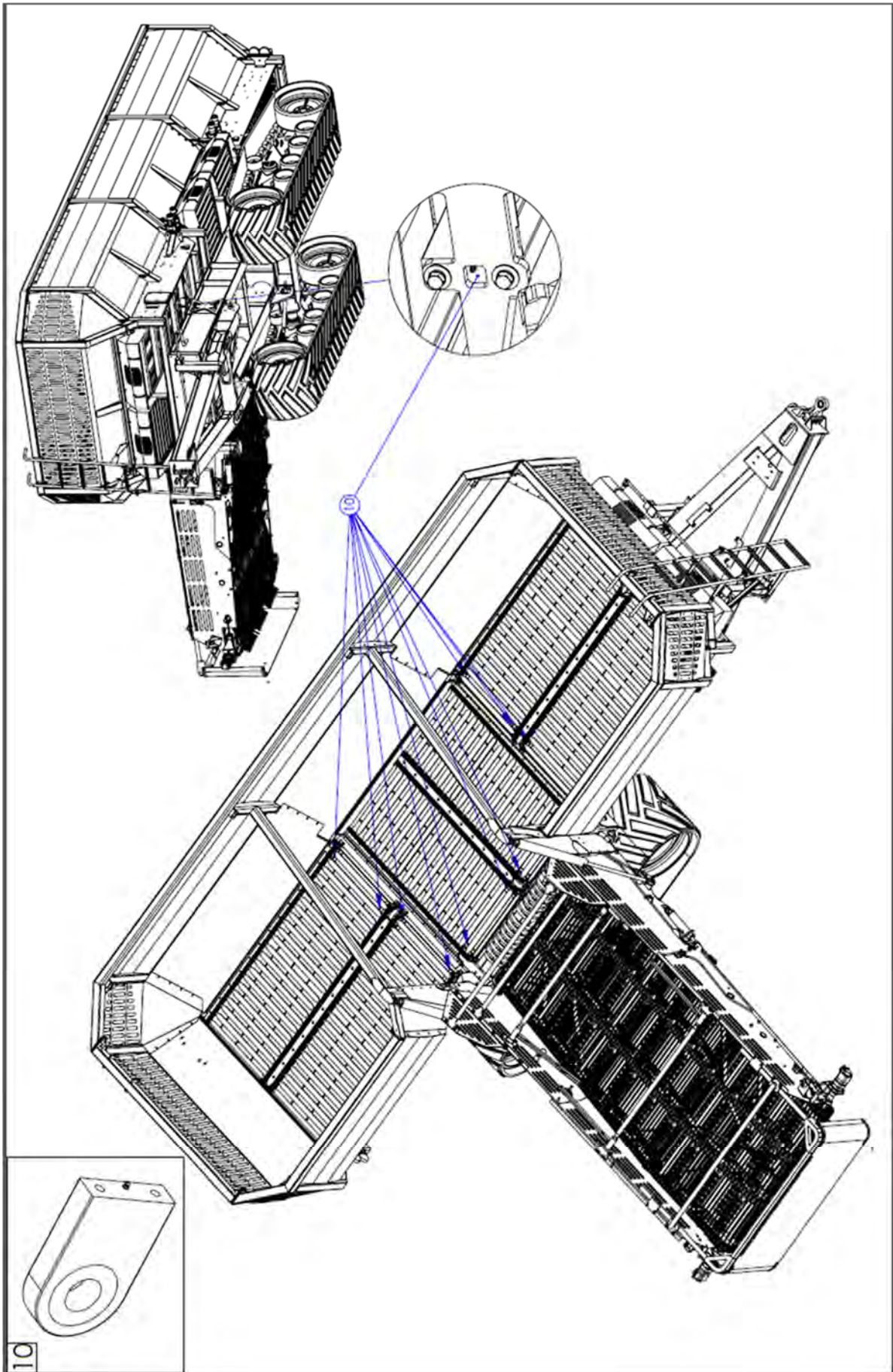

## 11.7 Lubrication Chart

Ref #	Description	Lubrication Type	Frequency	Quantity	Number of Instances
1	Floor Gearbox (PN 310807)	SAE 80W-90 EP	250 Hours/ Annually	1 Quart	3
2	Floor Ball Bearing (PN 57997)	Multi-Purpose Grease	12 Hours	1-2 Pumps	3
3	Hitch Pivot (PN 310796)	Multi-Purpose Grease	250 Hours/ Annually	1-2 Pumps	2
4	Planetary Gear Jack Stand (PN 310742)	Multi-Purpose Grease	250 Hours	1-2 Pumps	1
5	Hitch Pin Receiver (PN 310028)	Multi-Purpose Grease	12 Hours	1-2 Pumps	1
6	Universal Joint (PN 310893)	Multi-Purpose Grease	24 Hours	2-3 Pumps	1
7	Elevator Pivot Bearing (PN 310013)	Multi-Purpose Grease	250 Hours/ Annually	1-2 Pumps	2
8	Ball Bearing (PN 52405)	Multi-Purpose Grease	12 Hours	1-2 Pumps	4
9	Ball Bearing (PN 62135)	Multi-Purpose Grease	12 Hours	1-2 Pumps	1
10	Taped Base Bearing (PN 310396)	Multi-Purpose Grease	12 Hours	1-2 Pumps	12
N/A	Floor Drag Chain	SAE 20 (20 to 40 °F) SAE 30 (20 to 100 °F)	250 Hours/ Annually	As Needed	6
N/A	Tracks	Refer to Track Manual			2
N/A	Hydraulic System	SAE 10W Hydraulic Oil	N/A	70 Gallons	1

## 12.0 OPTIONS

If any options were purchased, please reference the following information regarding said option.

### 12.1 Scale

The scale system calibration code is: **07430**. All other needed information regarding the scale system can be found in the manual provided with the scale. If that manual is not available, you can reference: [http://www.agsscales.com/literature/640\\_u\\_en\\_43108\\_0019.pdf](http://www.agsscales.com/literature/640_u_en_43108_0019.pdf)

### 12.2 PTO

The PTO drive option is available for all model year Amity 35T beet carts. This option eliminates the need for high hydraulic flow to the unloading elevator chain in situations where the tractor does not have sufficient hydraulic flow capacity to unload the cart quickly. The unloading elevator drive circuit is driven from the pump that is mounted to the hitch of the cart and powered by a PTO connected to the tractor. The floor circuits are still operated by the tractor hydraulics. See your Amity Technology dealer for additional information on this option.

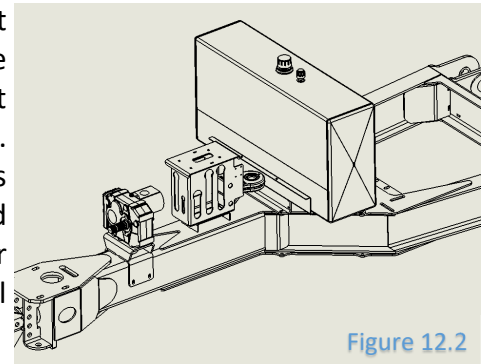



Figure 12.2

 **Important:** It is vital to use prescribed oils and oil quantities to ensure ideal performance of the PTO option, as well as to avoid any damages that could occur from misuse.

When operating the cart with PTO option always signal with tractor horn when engaging the PTO to let those near the machine know.

Be sure to never run the PTO without having the drive shaft installed properly, with the coupler hooked on tractor end and clamping bolt securing the shaft to the gear box. The hydraulic tank on purchased PTO option has a capacity of 70 gallons (250 Liters) of SAE 10W (ISO 32) hydraulic oil. Along with the tank, the gearbox holds its own 1.5 quarts (1.5 Liters) of SAE 80W90 (ISO 100) gearbox oil.

Tip tops are an option to increase capacity of your tank by 2-5 tons. Contact your local dealer or Amity technology for further assistance on information and aftermarket installation.

**NOTE:** Tip tops increase the transport height of your cart by approximately 6 inches as they sit above the folded elevator in the tank.

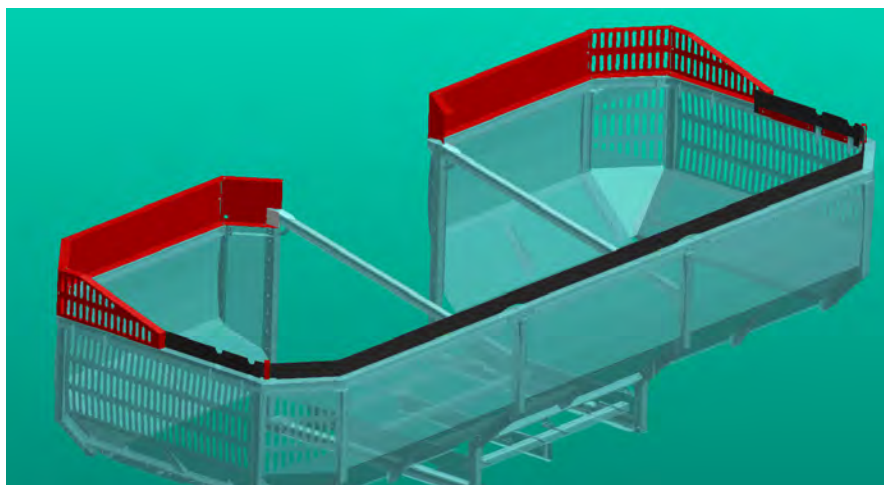

Figure: 12.3: Tip Tops

## 13.0 APPENDICES

### 13.1 Conversions

Table 12-1: Conversions

1 acre = 0.404 hectares	1 mph = 1.609 kph
1 acre = 43,560 square feet	1 mile = 1.609 km
1 inch = 2.54 cm	1 psi = 6.895 kPa
1 foot = 0.3048 m	1 GPM = 3.785 LPM
1 lb = 0.45359 kg	1 hp = 0.746 kw
1 lb = 16 oz	1 ft-lb = 1.356 N·m

### 13.2 Belted Chain Splice Procedure

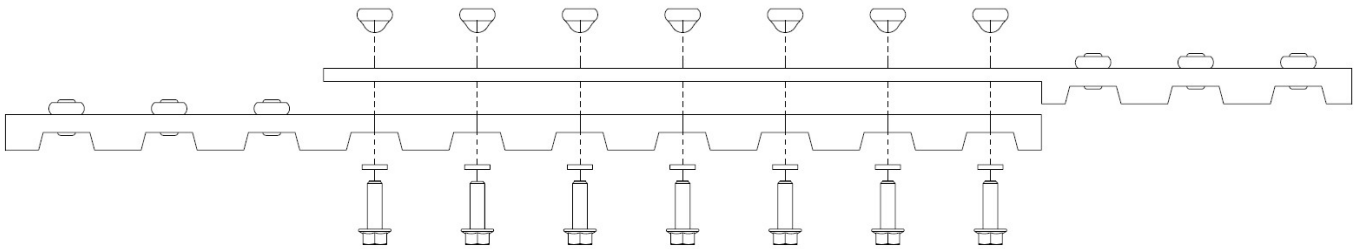

Figure 13.2: Belted Chain Splice Procedure

**NOTE:** Once the belt has been properly assembled and the clamping bolts have been torqued to the recommended 15 lb-ft (20 N-m), it is important to grind down the bolts on the plate side to eliminate any possible interference with the drive sprockets.

### 13.3 Torque Wrench Effective Length

To recalculate a torque reading when using a torque adapter, use the following formula, and refer to Figure 98:

$$TW = \frac{TA * L}{L + A}$$

**TW** is the torque setting or dial reading on the wrench.

**TA** is the torque specification (The actual amount of torque that should be applied to the fastener).

**A** is the amount that the adapter increases (or reduces) the effective lever length as measured along the centerline of the torque wrench.

**L** is the lever length of the wrench as measured from the center of the drive to the center of the grip.

The effective length of the torque wrench, measured along the centerline of the torque wrench, is the sum of **L** and **A**.

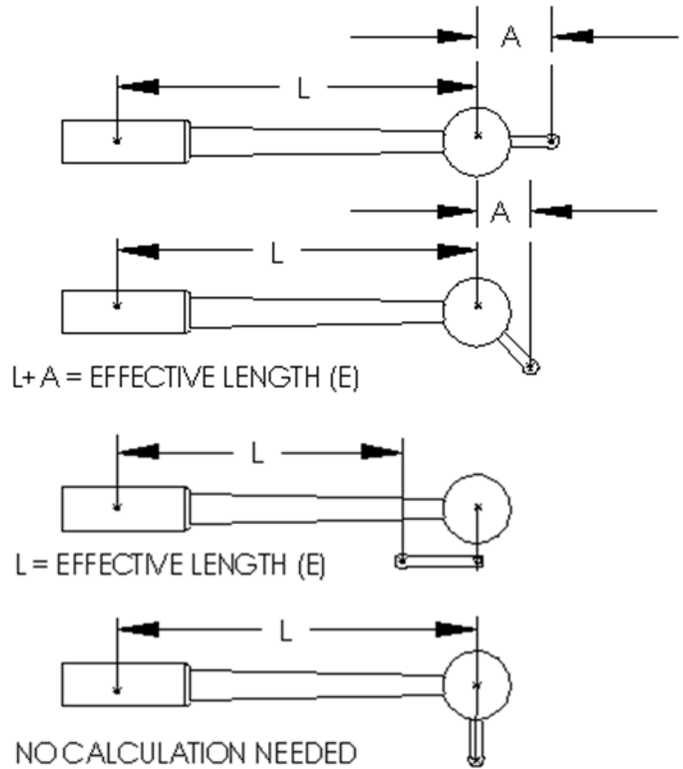

Figure 12-2: Torque Wrench Effective Length