

OPERATING MANUAL

2026

CAMSO 100TTS



2800 7th Avenue North
Fargo, ND 58108

Phone: (701) 232-4199
Fax: (701) 234-1716
www.amitytech.com

This page intentionally left blank

OPERATION AND MAINTENANCE MANUAL

TRAILED TRACK SYSTEM (TTS)

70 Series (236" Track, Including: 70-2516, 70-2517, 70-3011, 70-3012, 70-3611, & 70-3612)

80 & 100 Series (302" Track, Including: 80-3013, 80-3014, 100-3014, 100-3015, 100-3613 & 100-3614)

100 & 110 Series (324" Track, Including: 100-3612, 110-3614, 110-3615)

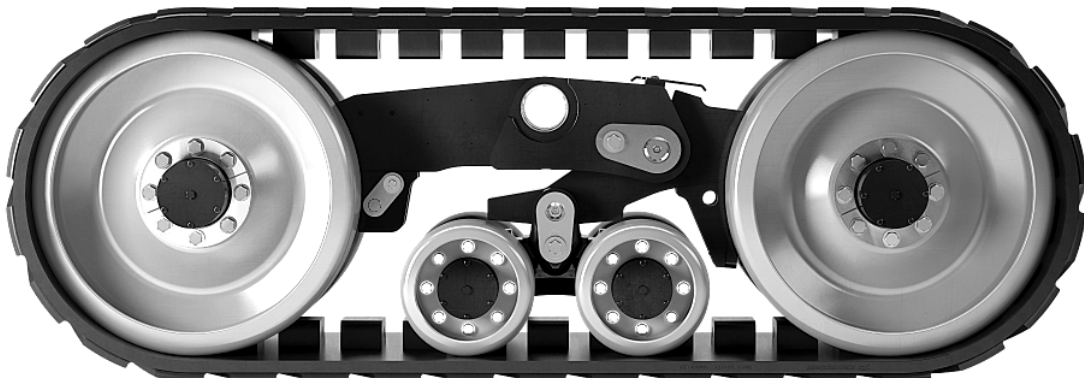

This page intentionally left blank

Table of Contents

1.0 FOREWARD	4
1.1 Literature Information.....	4
1.2 Maintenance Intervals.....	4
1.3 Camso Product Identification Number.....	4
2.0 SAFETY	5
2.1 Important Safety Information	5
3.0 GENERAL INFORMATION	5
3.1 Technical Description	5
3.2 Track System Components	6
3.3 Specifications and Dimensions.....	8
3.5 Transport Limitations	10
3.6 Minimum Turning Radius Limitations	11
3.7 Operational Guidelines	11
3.8 Track Break-in Procedures.....	12
4.0 TRACK SYSTEM INSTALLATION	12
4.1 Handling of the Track System	12
4.2 Track System Installation.....	13
5.0 SCHEDULED MAINTENANCE	17
5.1 General information	17
5.2 Lubricant Table	17
5.3 Maintenance Schedule	18
5.3.1 Daily maintenance or every 10 working hours	18
5.3.2 Weekly maintenance or every 50 working hours	19
5.3.3 Monthly maintenance or every 100 working hours.....	19
5.3.4 Annual maintenance or every 500 working hours.....	20
5.3.5 Every 5 years or 2000 working hours.....	20
5.9 Off Season Storage	21
6.0 ROUTINE MAINTENANCE	21
6.1 Check Track Alignment.....	21
6.2 Track Alignment Procedure	22
6.3 Track system inspection	23
6.4 Adjusting track tension.....	24
6.6 Track Installation.....	24
7.0 TROUBLESHOOTING.....	26
8.0 ADDITIONAL INFORMATION	26
9.0 WARRANTY CERTIFICATE.....	27

1.0 FOREWARD

This manual provides important operation and maintenance instructions to maximize the benefits of the Camso Trailed Track System (TTS) and to ensure performance in the field for many years to come.

1.1 Literature Information

This manual was prepared with the latest information available at the time of publication. Read this manual carefully before operating or servicing the undercarriage(s).

The photos, illustrations, and data used in this manual were current at the time of printing, but due to possible production changes, your undercarriage may vary slightly. Camso reserves the right make changes to new production undercarriages as necessary without notification. This document must be considered as an integral part of the rubber track system, it must always be available for reference near the machine, even in the case of sale, and until end of life. Should the operations and maintenance manual supplied with the track system be damaged or missing, please see your dealer to request another copy and/or contact Camso immediately.

1.2 Maintenance Intervals

Use the pulling machine hour meter to determine servicing intervals. Calendar intervals are also shown and can be used instead of hour intervals. Recommended service should always occur on the interval that occurs first. Under extremely dusty or wet operating conditions more frequent lubrication may be needed. Perform service on items at multiples of the original requirement. For example, at every annual or 250 hour service interval, also service items listed under monthly or 100 hours, weekly or 50 hours, and daily or 10 hours.

1.3 Camso Product Identification Number

The track system PIN plates will display the model and manufacturing date and sequence number on both LH and RH undercarriage system. Each undercarriage has a unique serial #.



If a serialized axle is also provided by Camso, it will also have a plate installed in the center of the axle. Track part # and serial # are embossed into the edge of the track carcass for ease of identification.

2.0 SAFETY

2.1 Important Safety Information

Read and understand this manual, the operation manual for the equipment the undercarriage is mounted to, and the manual for all attachments before operating, servicing or repairing an undercarriage.

Most personal injuries occurring during equipment operation, maintenance, or repair are caused by failure to observe basic safety rules and precautions. In most cases, an injury can be avoided by recognizing hazardous situations before an injury occurs.

A person must be alert to potential hazards. This person should also have the necessary training, skills and tools to perform these functions properly.

Improper operation and maintenance of this product can be hazardous and may result in injury or death.

Do not perform any lubrication, maintenance or repair on this product, until you have read and understood this Operators manual.

Safety precautions and warnings are provided in this manual. If these hazard warnings are not heeded, bodily injury or death could occur to you or to other persons.

Not every possible circumstance that might involve a potential hazard can be anticipated. The warnings in this publication are not all inclusive. If a tool, procedure, work method or operating technique that is not specifically recommended by Camso is used, you must satisfy yourself that it is safe for you and for others.

You must also make sure that the product will not be damaged or be made unsafe by the operation, lubrication, maintenance or repair procedures that you choose. The information, specifications, and illustrations in this publication are on the basis of information that was available at time of printing.

3.0 GENERAL INFORMATION

3.1 Technical Description

The Camso TTS allows machines to move on muddy and soft soils which have limited carrying capacity. The wide supporting surface of the track system also reduces soil compaction.

Camso track systems are mounted on an axle frame. Certain equipment requires a special axle to be installed prior to track system installation. Please contact your dealer for more information.

Camso track systems are designed to maximize the performance and productivity of your pull-behind applications with:

- Even weight distribution to easily and safely handle uneven terrain
- Excellent flotation to minimize soil disturbance (40 - 70% ground pressure reduction vs. tires)
- Maximum reliability to assure you get the job done anytime, anywhere

TTS uses Camso rubber tracks, specifically designed for pull-behind applications to provide:

- Reduced vibration during transport
- Lower turning resistance
- Minimal soil disturbance
- Long life

The patented undercarriage design incorporates independent movement of the midrollers both front-rear and side-side delivering:

- Even weight distribution, allowing tracks to follow ground contours
- A smooth ride over rough terrain
- Reduced point loads increasing longevity of the undercarriage and implement components

Besides the above listed characteristics, Camso rubber track systems introduce other advantages:

- Reduced power requirements on soft soils
- Minimal possibility of rubber track de-tracking from the undercarriage
- Adequate roading speed
- Limited soil damage, even during end of field maneuvers
- Reduced risk of self-sinking in the mud in case of slippage

3.2 Track System Components

Trailed Track System Terminology

1. Front Idlers
2. Rear Idlers
3. Midrollers
4. Tensioner
5. Alignment Adjustment bolt
6. Track Frame
7. Carrier Roller

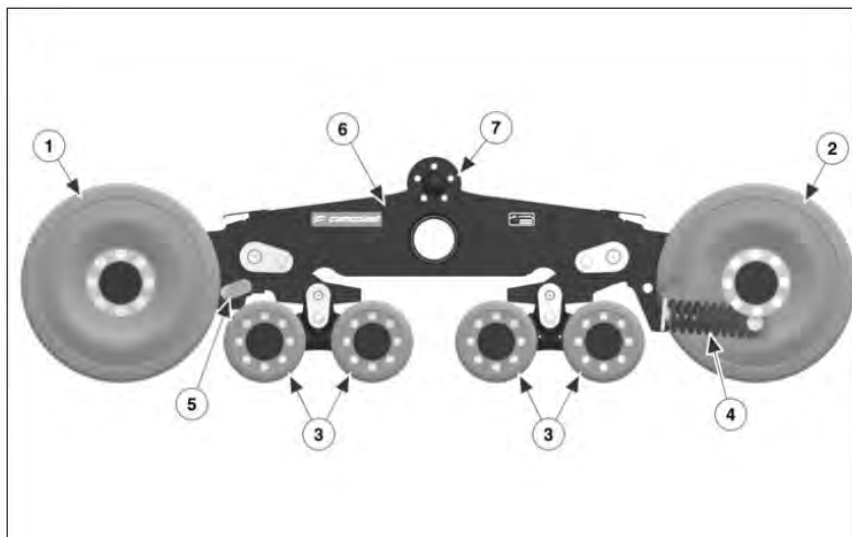

cp0805

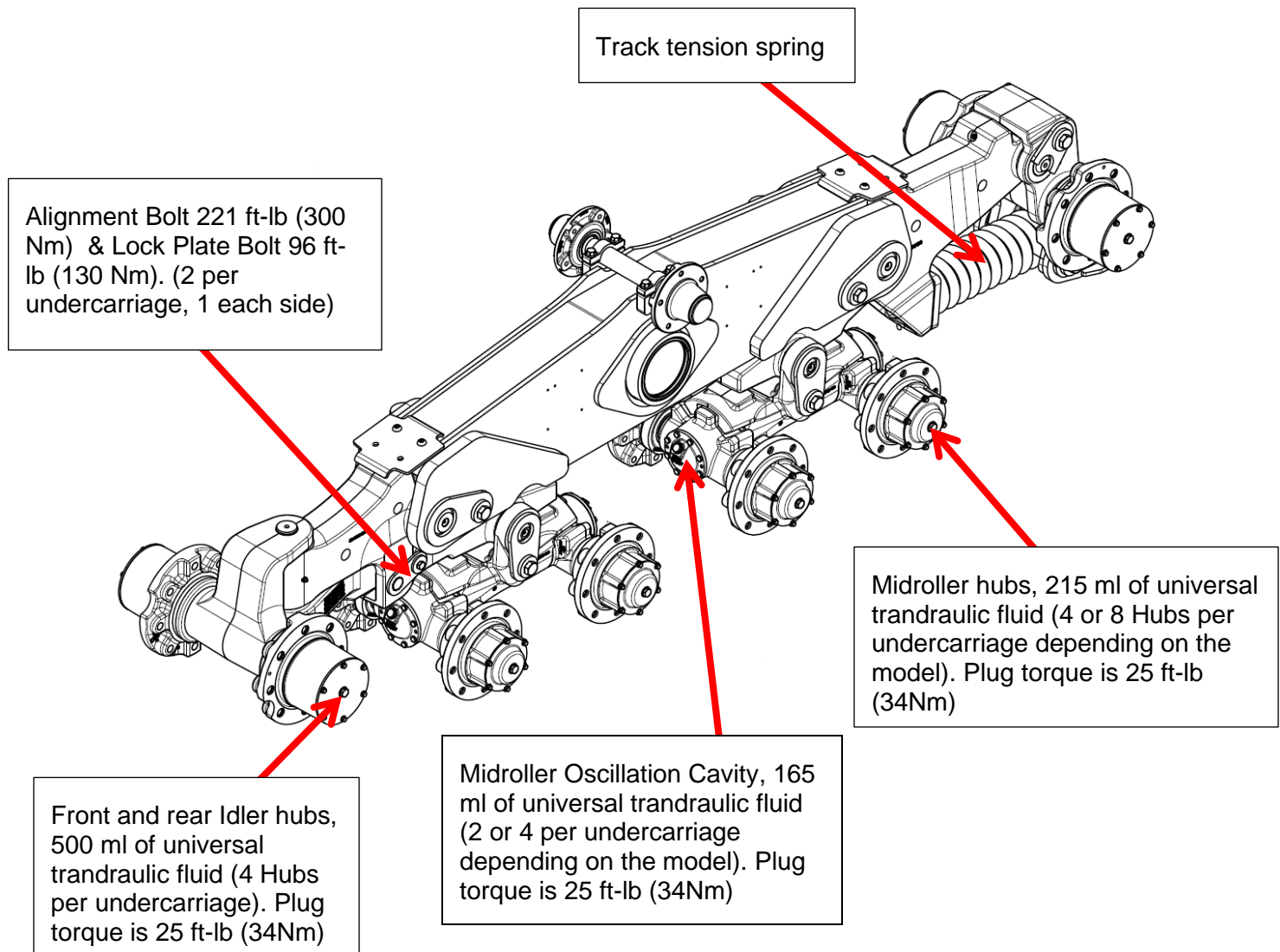

Frame

The main frame consists of a weldment or casting which hangs the front and rear link arms. The front alignment yoke and rear tension link are cast members, allowing for close tolerance machining and structural rigidity.

Axles

Front and rear axles are machined from the yoke castings, allowing for dimensional stability and few moving parts. They feature oil bath hubs mounted on tapered bearings and mechanical seals for extreme working conditions. Each hub has its own oil reservoir with access port for maintenance and checking oil levels.

Idlers and Midrollers

The idlers have the function of guiding the rubber track by acting on the lateral surfaces of the guide lugs. The midrollers distribute the majority of the machine weight to the ground. They are mounted on pivoting arms connected to the frame reducing vibration and shock loads.

Tensioning system

The tensioning system is located between the 2 rear idlers. The tension force is provided by a mechanical spring mechanism. Track tension is provided by the spring and does not need adjustment during operation and changing field conditions. Provisions are made to compress the spring allowing for removal of idlers and track assemblies during maintenance and servicing.

Rubber track

The rubber tracks are manufactured with high quality rubber and high strength steel cabling inside for superior durability and reliability. The tread layout ensures good flotation, excellent life, and self-cleaning characteristics.

3.3 Specifications and Dimensions

TTS Models	Track Width (in)	Overall Height (in)	Overall Length (in)	Ground Contact - Per Pair (sq-in)	# Bogie Axles Per UC	Capacity - Per Pair (lbs)
70 Series						
70-2516	25.0	36.1	103.5	3370	2	70,000
70-2517	25.0	36.1	103.5	3370	2	70,000
70-3011	30.0	36.1	103.5	4044	2	70,000
70-3012	30.0	36.1	103.5	4044	2	70,000
70-3611	36.0	36.1	103.5	4853	2	70,000
70-3612	36.0	36.1	103.5	4853	2	70,000
80 Series						
80-3013	30.0	40.3	136.2	6006	4	80,000
80-3014	30.0	40.3	136.2	6006	4	80,000
100 Series						
100-3014	30.0	40.3	136.2	6006	4	100,000
100-3015	30.0	40.3	136.2	6006	4	100,000
100-3613	36.0	40.3	136.2	7207	4	100,000
100-3614	36.0	40.3	136.2	7207	4	100,000
100-3612	36.0	40.3	147.4	8014	4	100,000
110 Series						
110-3614	36.0	40.3	147.4	8014	4	110,000
110-3615	36.0	40.3	147.4	8014	4	110,000

3.4 Weight Limitations

Camso track systems are limited to operating weights as listed in the table below. Do not exceed these weight limitations or track system damage or component failure may result.

Series	Total Scale Weight Capacity per Set (2 undercarriages)	
	Kg	Lbs
70	31,750	70,000
80	36,300	80,000
100	45,350	100,000
110	49,885	110,000

	<p style="text-align: center;">WARNING</p> <p>Exceeding maximum weight capacity may result in equipment and property damage, injury, death and void warranty coverage</p>
---	--

3.5 Transport Limitations

Camso track systems are designed for field use and field operational speeds. High speed transport, especially with loaded implements, is not recommended and may result in track damage due to heat. If extended transport is required between operating locations, the following speed and duration limits should be observed:

		Maximum Speed vs Allowable Weight at Rear Axle											
		(with track systems installed)											
	TTS Model	lbs	mph	lbs	mph	lbs	mph	lbs	mph	lbs	mph	lbs	mph
Replaced by 70-2517	70-2516	70,400	8	63,400	10	56,400	13	49,400	15	42,400	15	24,900	15
NEW	70-2517	70,400	8	63,400	10	56,400	13	49,400	15	42,400	20	24,900	25
Replaced by 70-3012	70-3011	70,600	8	63,600	8	56,600	10	49,600	13	42,600	15		
NEW	70-3012	70,600	8	63,600	8	56,600	10	49,600	13	42,600	20	25,100	20
Replaced by 70-3612	70-3611	71,300	14	64,300	15	57,300	15	50,300	15	43,300	15		
NEW	70-3612	71,300	14	64,300	15	57,300	20	50,300	20	43,300	20	25,800	20
Replaced by 80-3014	80-3013	82,100	11	74,100	13	66,100	15	58,100	15	50,100	15		
NEW	80-3014	82,100	11	74,100	13	66,100	17	58,100	20	50,100	20	30,100	20
Replaced by 100-3015	100-3014	100,800	15	90,800	15	80,800	15	70,800	15	60,800	15		
NEW	100-3015	100,100	7	90,100	9	80,100	12	70,100	15	60,100	20	35,100	20
Replaced by 100-3614	100-3613	100,800	15	90,800	15	80,800	15	70,800	15	60,800	15		
NEW	100-3614	100,800	15	90,800	15	80,800	20	70,800	20	60,800	20	35,800	20
Replaced by 110-3615	110-3614	110,200	12	99,200	15	88,200	15	77,200	15	66,200	15		
NEW	110-3615	110,200	12	99,200	15	88,200	15	77,200	20	66,200	20	38,700	20

Note 1: Max. allowable weights shown above include the weight of the track systems installed.

Note 2: Ratings based on 2 hrs of continuous operation.

Note 3: Exceeding speed and/or weight limits can cause damage to tracks and undercarriage components.

Note 4: Avoid driving on shoulders of road. Tracks should always be fully supported on road surface.



WARNING

Exceeding speed limitations may result in equipment and property damage, injury, death and void warranty coverage.

If additional distances are required, a 30 minute cool down period is recommended before transport is resumed. Absolute speed and duration levels may vary, depending on system type and ambient conditions. Limitations as listed, help avoid system heat buildup that could cause reduction in track life.

3.6 Minimum Turning Radius Limitations

Camso track systems operate best when running straight or in gentle turns. If a track system is pivot or spot turned, the opportunity exists for soil and dirt to be ingested into the system. Even though TTS has a tension recoil system, if that tension recoil is exceeded, high loads in the frame and track can be generated, which may cause track or system damage. Camso recommends that minimum turning radius limits be strictly observed, both in the field, and also on hard ground or pavement. This will help avoid high stresses due to debris ingestion, potential untracking situations, high twisting and side loads, and significant ground scrubbing of the track tread bars. This especially important when an implement is fully loaded.

Operating Condition	Minimum Turning Radius
Field or Road	1.5 x the overall length of the tractor + implement

3.7 Operational Guidelines

- Any application differing from the ones prescribed in this manual are to be considered improper and potentially dangerous.
- Correct track tension is required for best performance and track life.
- Camso TTS can work in extreme conditions: for operator and machine safety, be sure to know your surroundings.
- Camso TTS is free to pivot around the main axle following ground contours. During transition over uneven ground terrain, check for interferences and move slowly to avoid over oscillating the undercarriage.
- Overall width and height of machine/equipment with Camso TTS could differ from the original width and height with tires. Be sure to know actual machine height and width as well as width restrictions prior to operation.
- Cross large ground irregularities with suitable speed reduction and/or proper approach angle. In particular, when high, sharp bumps are crossed, move forward slowly to avoid shocks on the machine.
- Camso TTS does not damage standard road-bed constructions. Operators must know and respect road traffic laws.
- Rubber tracks have not been designed for extended use on the road. Camso is not responsible for track and system damage resulting for extended road use. Long road periods and/or roading at higher than recommended maximum speeds may cause premature wear or failure of the track or wheels and is not a warrantable condition. To reduce damage during roading, decrease overall machine weight and decrease machine speed. See “Transport Limitations” section for further information.

- Long runs on side slopes increase the wear on the side of guide lugs and idlers.
- Keep material out of the undercarriage. Inspect undercarriage daily, removing any material as necessary. In some conditions inspect more frequently.
- If a machine becomes stuck, clear away as much material from the undercarriage as possible prior to pulling the machine out.
- Avoid short turning radius turns and operation(s) especially when loaded. Spot turning creates debris ingestion and can also induce high torque loading in the system.
- Configure drawbar and hitch correctly during field operation(s).
- Use caution when operating track systems in loose, flowing material. Loose material can become trapped between track and idlers, resulting in track damage.
- Keep material out of the undercarriage. This may require scraping material out of tight places and in some conditions require frequent inspection and cleaning.

3.8 Track Break-in Procedures

Guide lug wear is reduced when correct break-in procedures are followed. During the break-in period, rolling components undergo a polishing-in process to achieve a smooth steel to rubber interface with the guide lug. Dust and dirt act as dry lubricants during track break-in and during normal operation to minimize heat generation and reduce rubber stickiness. New tracks should be exposed to dry and dusty soil conditions as soon as possible. Operation without dust or soil in the system, **especially during high speed roading**, generates high levels of damaging heat. If roading must be done, a dry lubricant such as soil, talc, graphite, oil dry, or cat litter should be applied to the guide lugs periodically during roading until field operation resumes.

IMPORTANT: NEW SYSTEMS REQUIRING EXTENDED TRANSPORT SHOULD BE CARRIED ON A FLAT BED AND NOT ROADED. DO NOT ROAD A NEW SYSTEM WITHOUT FIRST CHECKING ALIGNMENT AND INTRODUCING THE TRACKS TO DIRT OR DRY LUBRICANT

4.0 TRACK SYSTEM INSTALLATION

The Camso track systems are mounted on an axle frame. Certain equipment requires a special axle to be installed prior to track system installation. Contact your dealer for more information and to determine if the track system can be installed on your implement.

4.1 Handling of the Track System

The track systems can be handled by fork lifts lifting the machine from the base or by hoists using textile bands.

	<p style="text-align: center;">WARNING</p> <p>Danger of crushing. Use suitable lifting devices (capacity at least 9000 lbs (4100Kg)), wear safety equipment and observe the safety rules.</p> <p>If using a fork lift use, for handling operations, be careful not to damage the rubber track. Metal chains or cables are not recommended.</p>
---	---

4.2 Track System Installation

1. Clean the implement thoroughly before proceeding with the installation. Removal of dirt and debris makes access to the frame and attaching fasteners easier.
2. Move the implement to a hard surface and support the implement during installation.

Serial number Identification plate, unique serial number per undercarriage





IMPORTANT: Locate the identification tags, as shown above, on both undercarriages, and record the model number and serial numbers on warranty certificate for your records.

3. Raise and support the implement so the tires are just off the ground.

	<p style="text-align: center;">IMPORTANT</p> <p>Safety of the installation depends on the right operation in lifting and supporting the machine. Check the work area thoroughly and work in a level area. Respect safe operating practices, operate in conditions of enough light. Make sure the free spaces of the work area are suitable for the dimensions of the parts to be handled and for the lifting equipment maneuvers. Be careful: risk of injury.</p>
---	--

4. Remove the tire and rim assemblies.
5. Remove the axle and hub assemblies from the implement frame (as required).
6. Install track fitment axle. For two axle midroller track systems, make sure the stabilizer brackets on the axle are facing to the front of the implement. Tighten mounting hardware.

	<p style="text-align: center;">WARNING</p> <p>Danger of crushing. Use suitable lifting devices (capacity at least 9000 lbs (4100Kg)), wear safety equipment and observe the safety rules.</p> <p>If using a fork lift use, for handling operations, be careful not to damage the rubber track. Metal chains or cables are not recommended.</p>
	<p style="text-align: center;">IMPORTANT</p> <p>Should a motorized lifting device be used, assistance on ground during operation of handling, coupling and assembly is needed.</p> <p>Do not stand between lifting device and axle assembly when mounting axles to implement. Be careful: risk of injury.</p>

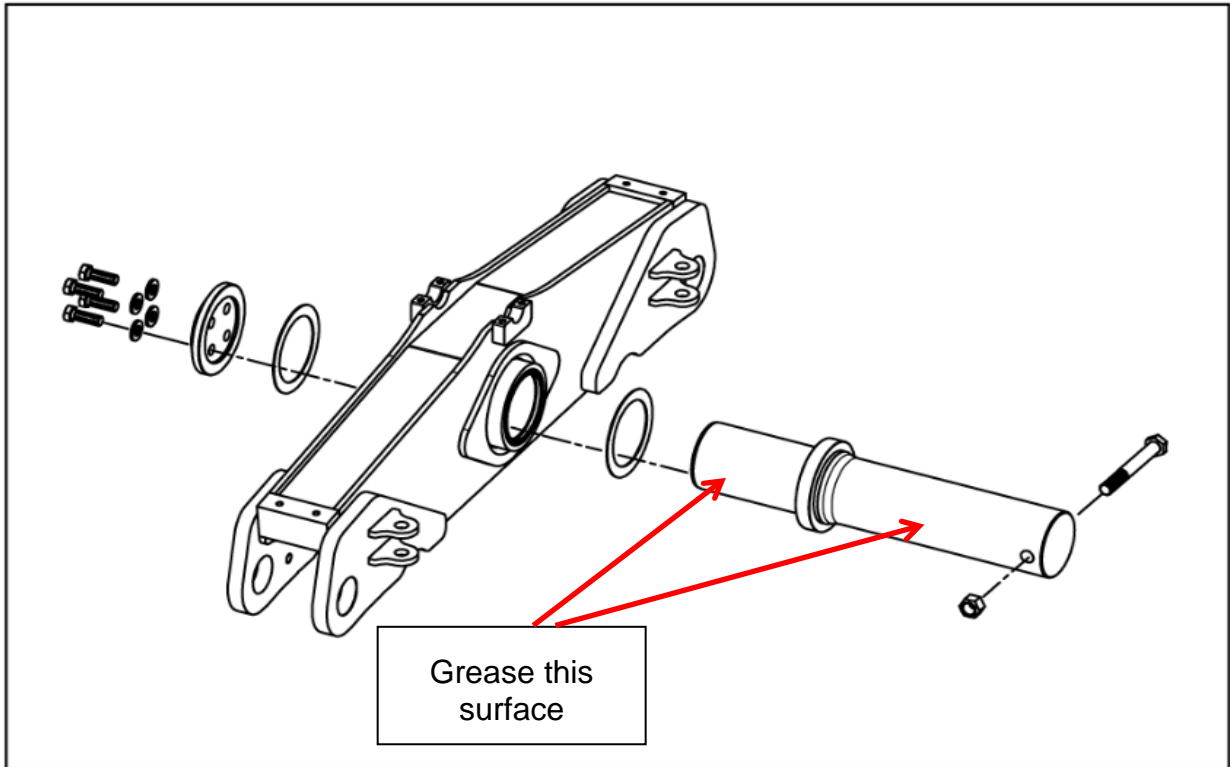

7. Lightly grease machined surface of center pivot pin and insert into the receiver end of the axle. Rotate the pin to align the rear mounting hole in the receiver pin. Install the bolt and locknut provided with the kit. Tighten pin bolt and lock nut to 130Nm (96 ft-lbs).
8. Install the inner thrust washer against the axle pin flange.
9. Apply a light amount of grease to the center pivot pin.
10. Slide the undercarriage onto the axle pin. NOTE: Care must be exercised to avoid damage to the lip seals on the center bore of the undercarriage assemblies during installation. Using a fork truck, lift the undercarriage assembly onto the center pivot pin.

	<p>WARNING</p> <p>Make sure undercarriage is installed with track tensioner assembly (spring) positioned to the rear of implement. DO NOT install the track system with the tensioner positioned to the front of the implement.</p>
---	--

11. Install outer thrust washer, retaining cap and retainer cap bolts & washers. Torque retainer bolts to 320 Nm (236 ft-lbs)
12. Repeat steps 7 through 11 for the other of the axle assembly.
13. Remove jack stands and/or supports and lower implement to the ground.
14. Install the stabilizer bars (if not required skip to step 15) to a **no pre-load** condition. Some slight play should be present at the rod ends. In special cases, some adjustment to the stabilizer bars may be required to achieve the desired front to rear parallelism dimension
 - a) For 2 axle midroller systems, attach the two, front stabilizer bars to the mounting brackets on the axle and the brackets on undercarriage frame with the hardware provided in the kit. Stabilizer end bolt torque 310 Nm (230 ft-lb)
 - b) For 4 midroller axle track systems, attach the two, front stabilizer bars and two, rear stabilizer bars to the mounting brackets on the axle and the brackets on undercarriage frame with the hardware provided in the kit. Stabilizer end bolt torque 310 Nm (230 ft-lb)
 - c) Torque turnbuckle jam nuts to 620 Nm (457 ft-lb).
15. Check and re-torque all wheel lug bolts as follows:

Wheel bolt diameter	Torque (Nm)	Torque (ft-lb)
M16	320	236
M20	620	457

5.0 SCHEDULED MAINTENANCE

5.1 General information

Three factors: proper use, regular inspections, and maintenance are essential to ensure proper performance and reliability of your Camso TTS track system.

It is strongly suggested to respect the recommended maintenance and inspection schedule in this section for best track system life, proper performance, and reduced downtime.

Before any operation, clean all debris and material from the track system and make a general analysis of the machine condition. Pay attention to wear components such as the track and inner flanges of the wheels. Identifying and resolving issues early reduces downtime and operating costs.

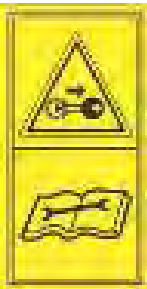
	<h3>IMPORTANT</h3>
	<p>Routine and extra maintenance must be performed by qualified and authorized personnel.</p> <p>Before starting any kind of operation on the machine, disconnect the transmission, stop the engine, set the emergency brake, remove the key, and allow machine to stop completely and cool.</p> <p>Ensure movable parts are safely secured and the proper tools are used for the type of service being performed.</p>
<p>Camso is not responsible for direct or indirect damage to people or objects due to tampering or modification of the safety devices.</p>	

5.2 Lubricant Table

Use and description	Location	Viscosity grade
Grease for heavy mechanical components	Carrier Axle hubs/bearings and frame pivot joints	NLGI GC-LB
Oil Bath Hubs and Pivots	Idlers and Midroller Hubs and Midroller axle pivots	Northland Universal Trandraulic Oil (or equivalent)

5.3 Maintenance Schedule

Task	Daily or 10h	Weekly or 50h	Monthly or 100h	Annual or 500hr	5 years or 2000hr
Inspect and clean track system	X				
Inspect track condition	X				
Check track alignment	X				
Inspect for oil leaks on idler, midroller hubs, and pivot axles	X				
Grease undercarriage and track system pivot points		X			
Check track tension			X		
Re-torque wheels			X		
Repack carrier roller hub bearings (if equipped). *				X	
Replace hub and pivot oil and set wheel bearing rolling torque. *					X

* Please refer to the Service Manual for detailed instruction

5.3.1 Daily maintenance or every 10 working hours

1. Clean and remove debris from track system. Material build-up on track system components can lead to excessive wear and premature failure.
2. Track system inspection. Walk around the machine inspecting each track system and axle assembly. Identifying and resolving issues early is key to improving track system life and decreasing operating expenses. See “Track System Inspection” in the Routine maintenance section for more information.
3. Check rubber track alignment daily by inspecting the guide lugs. If excessive wear or chunking of the guide lug is occurring, track alignment may need to be adjusted. For additional information, refer to the “Track Alignment Procedure” section.
4. Inspect idler, midroller, and midroller pivot axles for leaks. If any are noted, check oil level of the hub to be sure oil is up to the fill hole when on a level surface.

5.3.2 Weekly maintenance or every 50 working hours

1. Grease upper carrier hubs, undercarriage and track system pivot points.

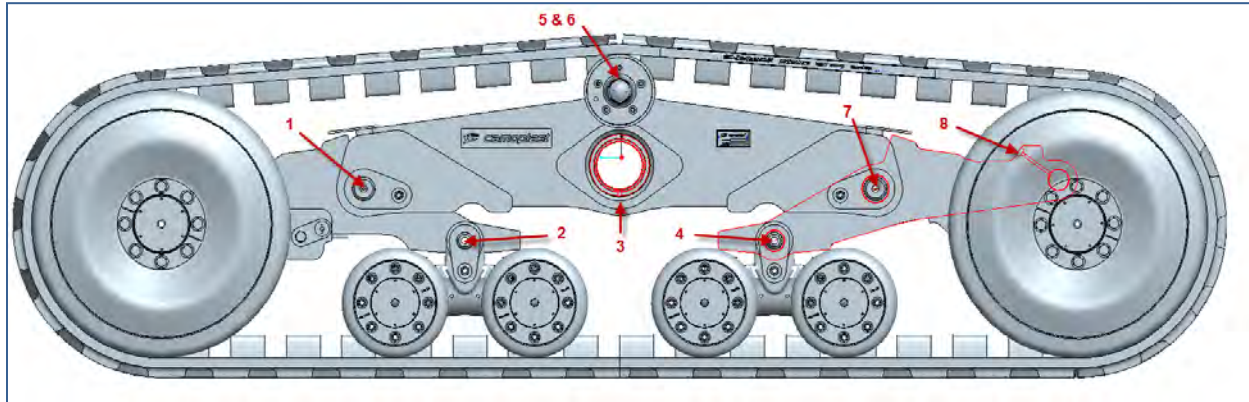

- #1 Tandem pin - front
- #2 Bogie pin - front tandem
- #3 Main central pin
- #4 Bogie pin - rear tandem
- #5 Carrier Roller – LH (if equipped)
- #6 Carrier Roller – RH (if equipped)
- #7 Tandem pin - rear
- #8 Tension link pin

5.3.3 Monthly maintenance or every 100 working hours

1. Check track tension. Refer to chart below for recommended setting. Refer to “Adjusting track tension” for additional information. No tension adjustment is required if spring module is functioning properly.

TTS Series	Tensioner Type	Spring Setting
70/80/100/110	Spring	No preload-onset of compression less one turn

2. Verify wheel bolt torque (always torque after wheel removal regardless of hrs.)

Wheel bolt size	Torque (Nm)	Torque (ft-lb)
M16	320	236
M20	620	457

3. Verify turnbuckle jamb nut torque. Tighten as required to 620 Nm (457 ft-lb)

5.3.4 Annual maintenance or every 500 working hours

1. Repack carrier roller wheel bearings (item 6) (if equipped).

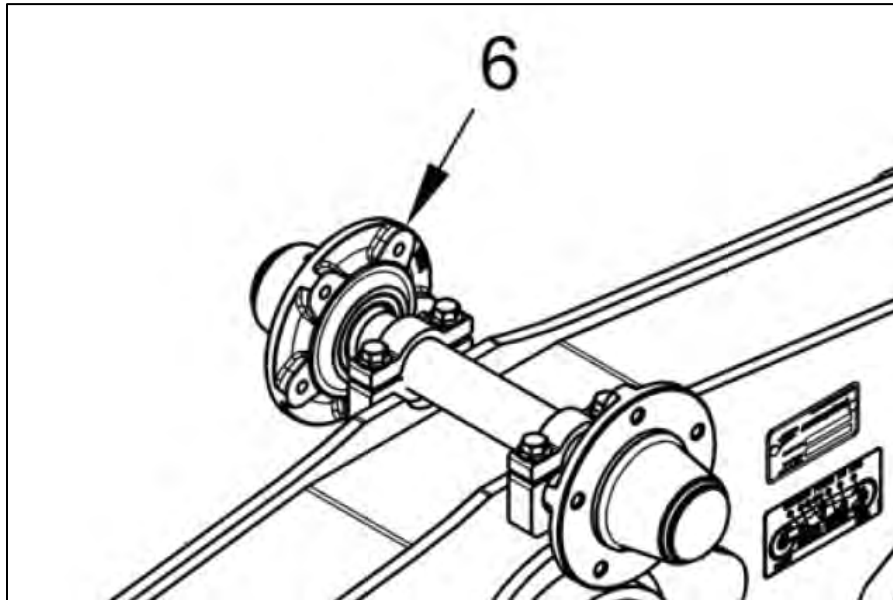

Carrier Roller Spanner Nut Size	Torque (Nm)*	Torque (ft-lb)*
N-06	10	7.4

* Spanner nut tool 2P-0022-100 is available from your Camso dealer

5.3.5 Every 5 years or 2000 working hours

1. Drain and replace idler hubs, midroller hubs, and midroller pivots.
2. Oil level should reach to lower level of fill plug with unit parked on level surface.

5.9 Off Season Storage

1. For optimum life, TTS tracks should be stored indoors, in dry environment with a temperature between 5° and 25° C (40-77F). The tracks should not be exposed to direct sunlight or heat. No petrochemicals and related vapors, no electrical devices producing ozone should be placed in the same area.
2. Should it be necessary to disassemble the tracks from the undercarriage, lay them on the ground on one edge avoiding bending radius less than 30 in.(750 mm). Do not lay the rubber components on dirty surfaces contaminated by oil, grease or other chemical products
3. Do not paint rubber components.

6.0 ROUTINE MAINTENANCE

6.1 Check Track Alignment

1. Install the stabilizer bars/turnbuckle assemblies to a “no” pre-load condition. Turnbuckle jam nut torque is 620 Nm (457 ft-lbs). Some play should be present at the rod ends. Make sure to unscrew the lock nut on the turnbuckle prior to adjusting the bars to the needed length.
2. Once installed, measure the inside distance between the two undercarriages (front and rear) to determine if they are parallel within 6mm (0.25 in.) A suitable location for measurements is noted in the below diagram by arrows below the turnbuckle eyes. It’s also a good idea to check diagonal measurements to verify the systems are square to each other. This can be done by measuring from center of the rear (inside) idler hub oil plug on the RH undercarriage, to the center of the front (inside) tandem pin on the LH undercarriage. Repeat the process using the center of the rear (inside) idler hub oil plug on the LH undercarriage, to the center of the front (inside) tandem pin on the RH undercarriage. The measurements should be equal or within an 1/8”.

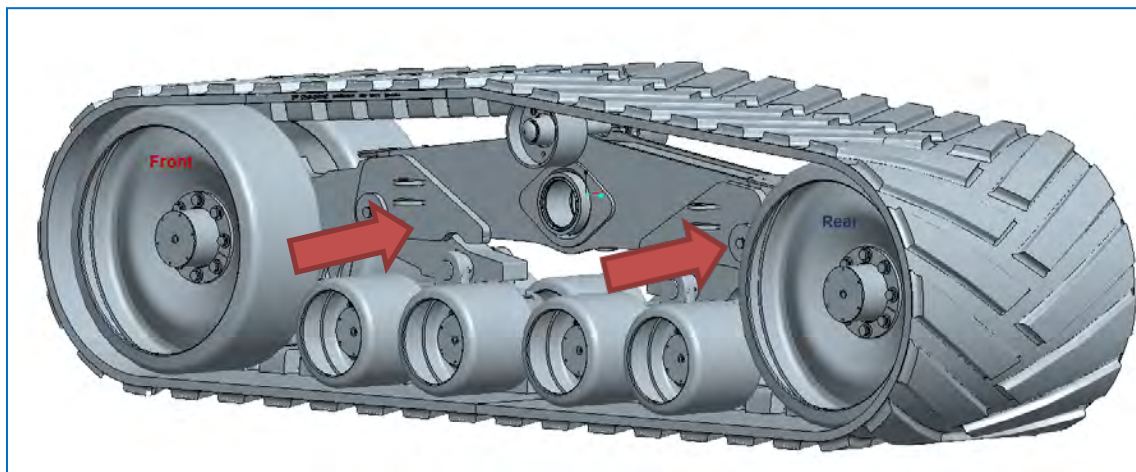

3. Prior to checking track alignment, the implement should be empty and have normal track tension (no spring pre-load).
4. Pull the implement on a flat surface for a suitable time frame, allowing the belts to relax and move freely on the undercarriage rollers.
5. Drive in a straight line for roughly 200 ft and coast the tractor to a stop. Place the tractor in PARK and apply the emergency brake. Do not apply braking action during this process as sudden stops can affect track position during the alignment process.
6. Slide a 1/4" thick X 4" X 8" shim (A) between the front midroller and adjacent guide lugs (B) making sure to bridge two guide lugs.

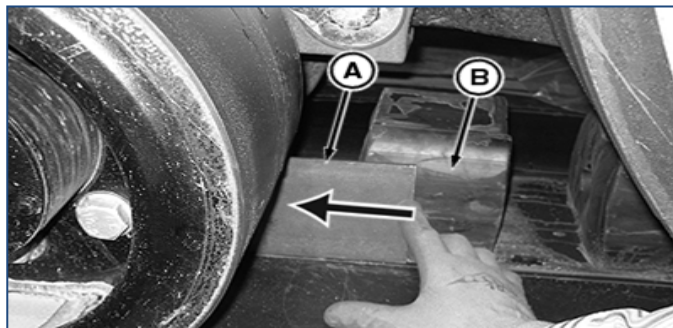

7. If the shim fits freely between the lugs and midroller on both sides of the undercarriage the alignment is correct. If the shim binds and does not fit between the midrollers/guide lugs track adjustment is necessary.

6.2 Track Alignment Procedure

1. Remove the retainer lock plate cap screws (b) and lock plate (c) from the **inboard & outboard** sides of the undercarriage needing adjustment.
2. Loosen cap screw (D) counterclockwise 1-1.5 turns on the side of the undercarriage you want the track to move towards ("A" represents location between inner idler wheel surface and guide lug in figure below).

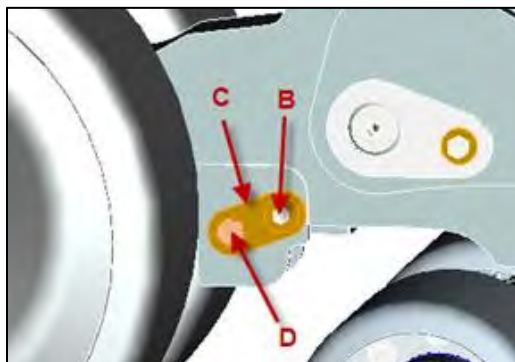

3. Tighten the special cap screw on the opposite side of the same undercarriage, to specification. Cap screw torque is 300 Nm (221 ft-lb). Tighten cap screw loosened in step 2 to the same specification. **Note: A single full turn is the standard increment during adjustment. Lessen this amount as final adjustment is approached.**
4. Recheck track alignment and adjust until suitable clearance is obtained on both sides of the guide lugs. **Note: Lock plates are reversible for double the index increments. If needed, increase torque on the special cap screw slightly allowing advancement to a suitable lock plate position.**
5. When alignment is complete reinstall the lock plates and tighten cap screws to their required torque specification of 130 Nm (95 lb-ft).

6.3 Track system inspection

Track System

Inspect track system for material build-up on frames and wheels. Clean material from undercarriage. Material build up on idler wheels can affect track alignment and produce additional heat buildup.

Idlers and midrollers

Check the general condition of the idlers and midrollers, in particular on inner flange surface of the wheels. Excessive wear in these areas can be caused by track alignment issue, debris ingestion or continuous hillside work.

Rubber track guide lugs

Guide lugs keep the track on the track system. Proper alignment of the track is essential to improving overall life and decreasing operating costs. If track is misaligned or operating on side slopes, guide lug wear or damage may occur. Also guide lug damage may occur if proper break-in procedures are not followed or system is operated outside the maximum speed recommendations listed in this manual. Monitoring guide lugs can alert the operator to track or undercarriage problems. In general, if caught and corrected early, no loss of performance or component life are experienced.

Track carcass

Inspect track surface to remove imbedded stones or debris. This contamination can work its way into the track and damage the steel cable.

Steel wire may come out from the track carcass without affecting the performance of the track. Remove loose wires by cutting them at the rubber surface.

Track tread

Muddy soils usually cause limited wear, while roading long distances can bring about accelerated tread wear. Due to the crown of the road, and deflection in the system, the

tread closest to the machine will tend to wear faster than the tread on the outer portion of the track. Adhere to speed and weight limitations published in this document.

6.4 Adjusting track tension

Tension is pre-set at the factory and requires no adjustment during operation. Provisions are made to detension the track system allowing for removal of the rubber track.

6.5 Track Removal

1. Place the undercarriage on a level surface and loosen the nuts on the outer idler wheels. Undercarriage may not need removal from the implement to be worked on.
2. Locate the tension module located between the rear idlers. Remove the 2 bolts fastening the rotation lock to the frame. Remove the lock.
3. Turn the track tension screw clockwise to compress the spring which loosens the track. Turn the screw until suitable track tension reduction allows for removal of front/rear outer idler wheels. Do not force the bolt, which may cause the spring to bind.
4. Using a suitable lifting device raise the undercarriage until there is clearance between the midroller wheels and track guide lugs.
5. Remove the wheel bolts and clamping plates. **Note: idler wheels weigh 113kg (250lbs) and will roll easily on a firm surface. Place a stop under removed wheels to stop rolling and potential injury.**
6. Remove the inner idler wheel.
7. Using a suitable lifting device, lift the track slightly near the front and rear idlers, pulling slightly away and back from the undercarriage to remove the track. **Note: If using a forklift or other steel lifting device, ensure the tines or lifting surface does not have sharp edges or track damage may occur.**
8. Lift the track up and away from the undercarriage, placing in a suitable location for installation.

6.6 Track Installation

9. Raise the undercarriage roughly 12 in. from the ground to allow for the lower surface of the belt and guide lugs to slide underneath the midroller wheels.
10. Lift the track and install on the top carrier rollers. Push the bottom of the track under the midrollers and around the front and rear inner idlers.

11. Install the outer idler wheels removed previously, ensuring the guide lugs are positioned properly between the midrollers and idlers. Idler wheel bolt torque is 620Nm (457 ft-lbs).
12. Lower the undercarriage assembly to the ground. Turn the tensioning screw counterclockwise to extend the tensioning spring. The screw should be retracted until there is no preload on the spring. Thread the screw in to the onset of compression and back off $\frac{1}{2}$ turn.
13. Install tensioning screw rotation lock and torque retainer bolts to 130 Nm (96 lb-ft).

7.0 TROUBLESHOOTING

Problem	Possible cause	Solution
Uneven tread wear	High amount of roading	Swap tracks side to side
Splits/opening on the side or top of tread	High amount of roading or overheat of tread	Swap tracks side to side, replace tracks if necessary
Chunking on guide lug sides	Track not aligned properly	Align track, see “Track Alignment Adjustment” section
	Improper break-in of track	Operate in dry dusty conditions, see “Track Break-in” section.
	Side slope operation	Contact Dealer
Breakaway of track guide lugs	Material or workmanship defect (clean separation)	Contact Dealer
	Debris/material ingestion into track system. (jagged separation)	Clean material from undercarriage and verify proper operational techniques
Correct tensioning not possible	Verify position of track detensioning bolt at rear idler assembly	Bolt fully retracted with no preload on spring applied
High temperature of idler or roller axle hub	Bearing failure	Replace damaged bearing
	Lack of lubricant	Check oil level in hub
Noise from idler or roller axle hub	Bearing failure	Replace damaged bearing
Mud/dirt build up on idlers/midrollers	Operation in muddy, wet, or sticky soil types	Clean mud/dirt regularly to prevent track damage.
System dog tracking or problems with track alignment	Alignment adjustment incorrect. Undercarriage parallelism is out of tolerance	Adjust alignment per procedures otherwise, contact your Dealer

8.0 ADDITIONAL INFORMATION

Additional information on Camso track systems, tracks, and our other products may be found at <http://www.Camso.co>.

For any questions or corrections regarding this manual, please email us at Ag.Productsupport@Camso.co . You can also contact our Customer Service Desk @ 317-671-7327 or 1-844-226-7624.

Please include the manual publication number and edition as found in the footer

9.0 WARRANTY CERTIFICATE