

Soil Sampler 2400

Operating & Parts Manual



Amity
TECHNOLOGY



Field-proven Solutions

amitytech.com

2800 7th Avenue North
Fargo, ND 58102

P 701.232.4199

F 701.234.1716

Operating & Parts Manual

2400 In-Cab Soil Sampler

Amity

TECHNOLOGY

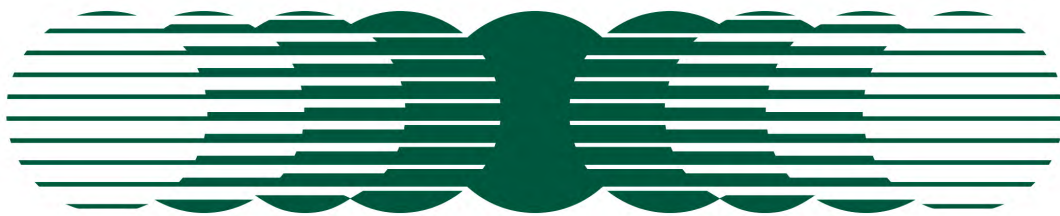

2800 7th AVE N Fargo,
ND 58102

Phone: (701) 232-4199

Web: amitytech.com

INTENTIONALLY LEFT BLANK

AMITY TECHNOLOGY, LLC PRODUCT WARRANTY

Amity Technology, LLC warrants to the original purchaser only, each new item of Amity Technology sold by it to be free of defects in workmanship materials for a period of twelve (12) months from the date the product is delivered to the Purchaser (Warranty Period).

The sole obligation of Amity is limited to the repair or replacement, whichever Amity chooses, of those parts which Amity, in its sole discretion, determines to have failed as a result of a defect in workmanship or material occurring during the Warranty Period. Such defective part will, at the option of Amity, either be repaired or replaced to the Purchaser through an authorized Amity dealer. The Purchaser must, within the Warranty Period, give written notice to an authorized Amity dealer and the dealer will have a reasonable time to repair or replace the defective part. Amity's dealer's claimed labor hours must be fair, reasonable and consistent with industry practice.

This Warranty does not cover damage to other parts of the product caused as a result of delay by the Purchaser to repair or replace defective parts. Amity will not be liable for direct or indirect costs other than those specified and this Warranty specifically excludes damage to crops, loss of use, transportation expense to a dealer, service calls, normal maintenance and upkeep costs, overtime labor costs, and any and all other injuries, claims or consequential damage or other economic loss. This Warranty does not cover damage caused to or by any equipment, accessories or parts attached to or used in connection with Amity equipment. This Warranty shall be void if alteration, modifications or additions are made to Amity products without written consent of Amity, or if in Amity's judgment, the failure was due to abuse or neglect in the operation or maintenance of the product. This Warranty shall only apply if Amity equipment is used for its recommended agricultural purpose. No dealer, salesman, or agent has any authority to alter or amend this Warranty.

**THIS WARRANTY IS IN LIEU OF ALL OTHER WARRANTIES,
EXPRESSED OR IMPLIED, AND THERE IS NO WARRANTY OF
MERCHANTABILITY OR FITNESS FOR A PARTICULAR PURPOSE.**

WARRANTY VOID IF NOT REGISTERED

INTENTIONALLY LEFT BLANK

PLEASE READ THE FOLLOWING INFORMATION REGARDING THE WARRANTY REGISTRATION OF YOUR NEW 2400 IN-CAB SOIL SAMPLER

Thank you for your purchase. Amity Technology, LLC will warranty each new 2400 In-Cab Soil Sampler to be free from factory defects in material and workmanship under normal use and service, when operated in accordance with factory instructions. Warranty will cover a period of one year from the date of purchase.

Amity Technology's obligation under this warranty is limited to the supplying of replacement parts in exchange for any parts which are defective. The warranty does not cover normal wear from usage. This warranty is void on any unit which has been tampered with or which has been subject to misuse, negligence or accident. Any part being returned for warranty service must be sent to Amity prepaid, and will be returned to you at our expense.

To obtain registered warranty coverage, please complete the section below and return it to Amity within 30 days of purchase.

Customer Name _____

Address _____

City _____ State/Prov. _____

Zip Code _____ Phone # _____

Email Address _____

Dealer Name _____

Address _____

City _____ State/Prov. _____

Purchase Date _____ Customer Signature _____

Return to: Amity Technology, LLC
2800 7th Avenue North
Fargo, ND 58102
701.232.4199
701.365.8323 fax

INTENTIONALLY LEFT BLANK

In-Cab 2400 Soil Sampler

This hydraulic sampling system is designed to collect soil samples up to 24". The system is powered by a 12 volt electric over hydraulic power unit. The full cycle time of this unit will be approximately 12-16 seconds (down and up) which will vary depending on ground conditions. The 2400 In-Cab Sampler will push through 24 inches of frost in **most** conditions when mounted inside the truck cab.

The 30" cylinder comes attached to the mast, which is a C-channel that supports the cylinder vertically. To mount this inside the cab, find an area that is 6" x 6" where the soil probe can go through between the frame and the exhaust system of the vehicle. Place this hole as close to the operator as possible so that the cylinder is easily accessible to attach the probe. Then cut the 6" x 6" hole in the floor, again double checking the clearance. Next, use the two L-brackets to fasten the 3" x 3" main support tube to each side of the frame of the vehicle, aligning this just next to the hole that was cut in the floor of the cab. Slide the H-bracket on to the 3" x 3" tube. A hole will need to be drilled through the tube to fasten these two items if they are not being welded. Mount the cylinder mast with the probe attached so that the bottom of the probe is 6-8 inches off the ground, this will allow for enough clearance to attach and remove the probe while still being able to retrieve a full sample.

Next, find an appropriate place for the power unit (preferably in the box). Route the hydraulic hoses to the cylinder using quick ties to secure them. Quick attach couplers (not provided) will allow for easy dismantling of the unit when not in use. The hydraulic reservoir has a capacity of three quarts. Oil level should be 1" to 1.5" below the top of the reservoir. Many types of hydraulic fluid can be used, but we recommend using automatic transmission fluid (ATF).

Routing the power cable to the battery should be the last step of mounting. Make sure cable is clear of any sharp edges, heat, belts, and ground; this will insure longer life of the cable. Be sure the white cable is connected to the positive terminal and the black cable to the negative terminal. It is extremely important that the power unit is grounded properly; use the two threaded mounting holes on the bottom side of the center block for the best ground connection. **NOTE: THIS IS DONE BY USING THE NEGATIVE WIRE FROM THE POWER CABLE COMMIING FROM THE BATTERY. Most issues with the power unit can be traced back to poor electrical connections, with the ground connection being the main cause.**

Congratulations on mounting the sampler! Happy sampling!!



Inside mounting example



Inside mounting example, rubber dust seal.



Cross member can be bolted or welded to frame.



Example of H-bracket assembly



Power unit mounted in box



Layout of 3 x 3 tube and brackets



Quicktatch collar for fast removal of soil probe

Do "Not" Operate The Pump Before Filling Reservoir According To Directions

Connect power cable here

Ground cable
One possible location

Power Unit Mounting plate must be well grounded for most power:
"Always check ground if unit lacks power". For best ground connection run cable directly to the battery..

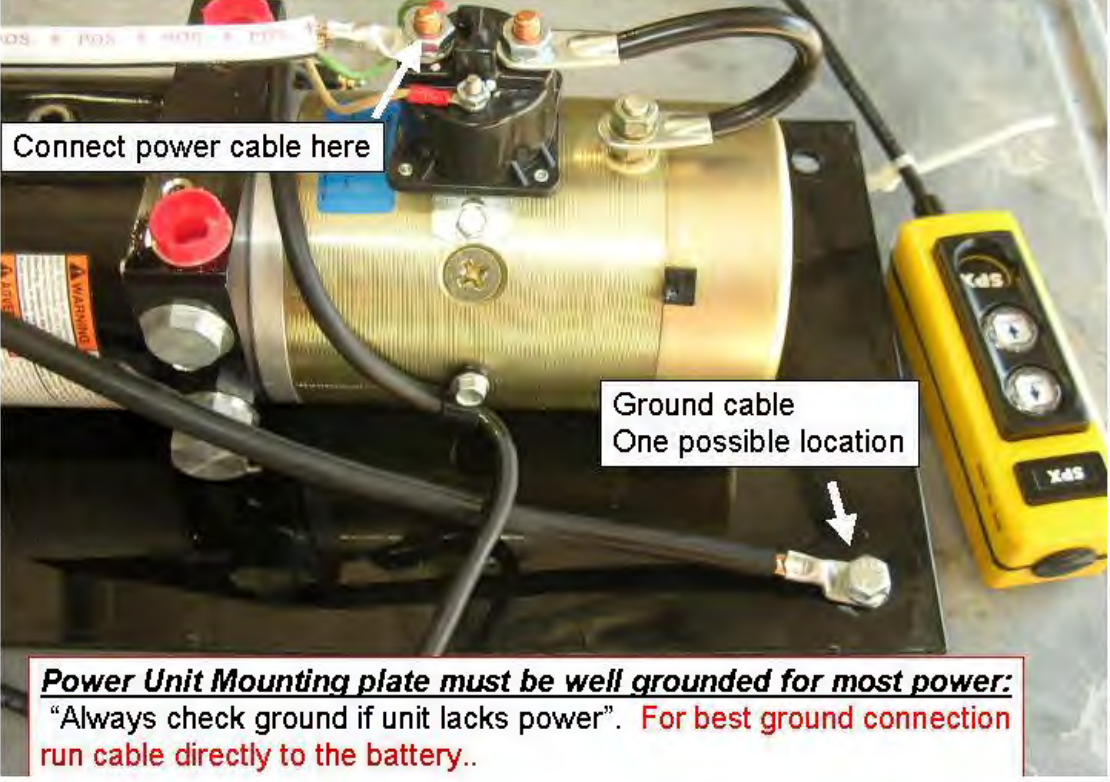

INTENTIONALLY LEFT BLANK

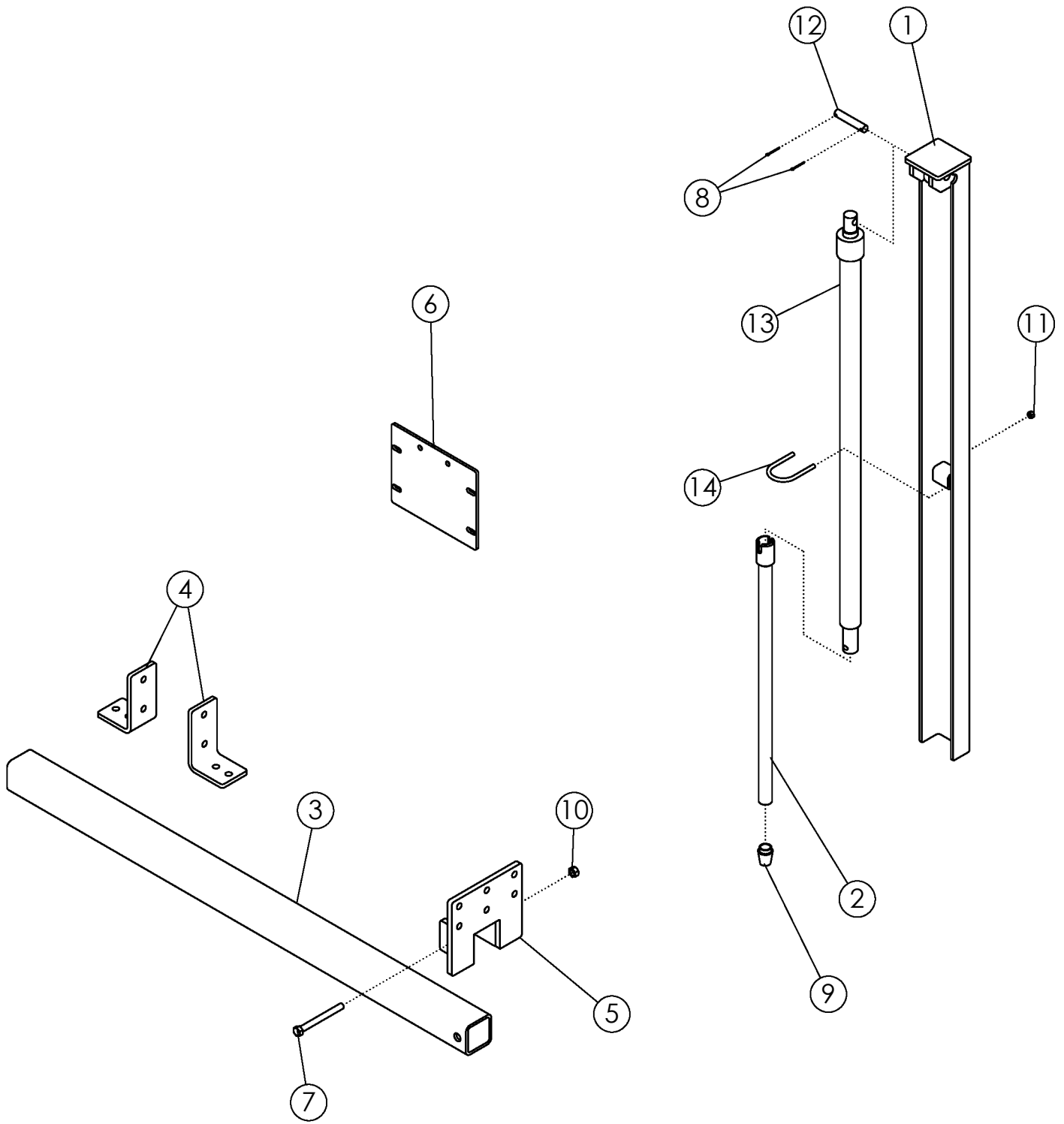

2400 IN-CAB SOIL SAMPLER PN: 1060355

ITEM	PART NO.	DESCRIPTION	QTY
1	1060279	WLDMT-IN CAB	1
2	1060031	WLDMT-SLTD PROBE END CAP 24' SS	1
3	1060042	TUBE-2400 IN-CAB MOUNT	1
4	1060043	ANGLE-2400 IN-CAB MOUNT	2
5	1060044	WLDMT-2400 IN-CAB MOUNT	1
6	1060048	PLATE-MOTOR MOUNT	1
7	1011618	BOLT-HEX: .50 X 5.00 NC GR5 ZP	1
8	1013626	PIN-COTTER: .16 X 1.25 ZP	2
9	1040969	DRY, C #1	1
	1030206	WET, C#1	
10	1027461	NUT-TOPLOCK: .50 NC GR5 ZP	1
11	1030700	NUT-TOPLOCK .38 NC GR5 ZP	2
12	1060283	PIN-CYLINDER ANCHOR ZP	1
13	1060280	CYLINDER-HYDRAULIC 1.5" X 30	1
14	1060284	U-BOLT: .31 X 3.5 ROUND	1

